



## JT Gladiator 2020-Current Upper control arm brackets, coil buckets, and track bar bracket

Thank you for your purchase!

### Installation Notes:

- This bracket set is designed to replace the OEM Brackets.
- This bracket set fits Jeep JT Gladiator 2020-Current.
- Installation of this product requires a trained welder.
- Cutting off existing bracketry is required for installation.
- Refer to your vehicle's factory service manual for removal of any factory components.

### Tools required:

- Welding machine with the capability of welding at least ¼" steel.
- Proper cutting tool (Grinder with cut off wheel, plasma cutter, cutting torch, etc.)
- Tape Measure
- Angle Finder

Bill of Materials			
QTY	Part Number	Etch Number	Description
1	B4W250955	955 B	JT Rear, Axle Side, Track Bar Bracket.
1	B4W250953	953 B	JT Rear, Driver Side, Coil Bucket.
1	B4W250951	951 B	JT Rear, Driver Side, Upper Control Arm Bracket.
1	B4W250954	954 B	JT Rear, Passenger Side, Coil Bucket.
1	B4W250952	952 B	JT Rear, Passenger Side, Upper Control Arm Bracket.
4	B4W188971	971 B	TJ Rear Coil Spring Center Half.
2	B4W188972	972	TJ Rear Coil Spring Center

### **Step 1:**

After Referring to your vehicle's factory service manual. Remove the coil springs, upper control arms and track bar as instructed in the manual.

### **Step 2:**

Measure the location of the OEM brackets on the axle. Make a note of these measurements the Barnes 4WD brackets will need to be in the same location as the OEM brackets.

### **Step 3:**

Using the proper cutting tool remove the OEM brackets.

### **Step 4:**

Place the new Barnes 4WD bracket set in the same location as the stock brackets. The image below is for reference. Locate the driver side first and then use it to locate the passenger. Both coil buckets should be parallel with the bump stop pad surface.

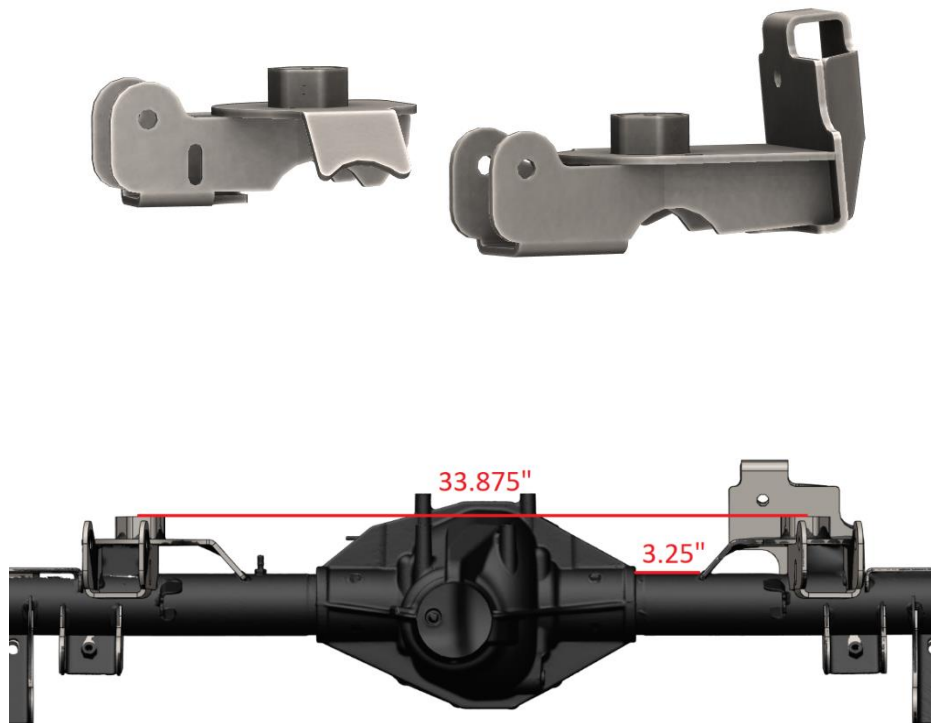

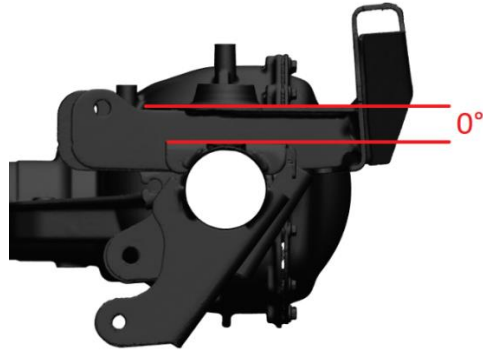

### **Step 5:**

Tack the brackets into place. Cycle the suspension to check functionality.

### **Step 6:**

Fully weld the brackets together and to the axle.

### **Step 7:**

Reinstall the coil springs, upper control arms and track bar according to the factory service manual.

Congratulations! You have completed the Installation.

#### Professional Services Disclaimer:

The content of all pages of this website (collectively, the "Website"), such as text, graphics, images, information and other material (collectively, "Content") is for informational purposes only. Any information furnished on this Website is not intended nor implied to be automotive advice and is not intended to replace personal consultation with a qualified automotive service technician, mechanic, or similar automotive professional.

Barnes 4WD has not examined the Content for accuracy, timeliness, completeness, appropriateness, or helpfulness. Barnes 4WD does not endorse any specific tests, products, procedures, opinions, or other information that may be mentioned on this Website. Your reliance upon information and Content obtained by you at or through this Website is solely at your own risk. IN NO EVENT SHALL BARNES 4WD BE LIABLE OR OTHERWISE RESPONSIBLE FOR ANY DAMAGE OR INJURY (INCLUDING DEATH) TO YOU, OTHER PERSONS, OR PROPERTY ARISING FROM ANY USE OF ANY PRODUCT, INFORMATION, IDEA, OR INSTRUCTION CONTAINED IN THE CONTENT.

BARNES 4WD DOES NOT MAKE ANY REPRESENTATION OR WARRANTY, EXPRESS OR IMPLIED, AT LAW OR IN EQUITY, WITH RESPECT TO ANY PRODUCT FEATURED ON THE WEBSITE, INCLUDING WITHOUT LIMITATION WITH RESPECT TO MERCHANTABILITY, FITNESS FOR ANY PARTICULAR PURPOSE, VALUE, VALIDITY, OR ENFORCEABILITY, AND ANY AND ALL SUCH OTHER REPRESENTATIONS OR WARRANTIES ARE HEREBY EXPRESSLY DISCLAIMED.