



Jeep JL Front Axle Lower Control Arm Brackets Installation Instructions

Thank you for purchasing our Jeep JL Front Axle Lower Control Arm Brackets!

Installation Notes:

- This bracket is designed to replace the OEM JL Front Axle Lower Control Arm Brackets
- This bracket fits 2018-Current Jeep Wrangler JL and 2020-Current Jeep JT Gladiator
- Installation of this product requires a trained welder.
- Cutting off existing bracketry is required for installation.
- Refer to your vehicle's factory service manual for removal of any factory components.

Tools required:

- Welding machine with the capability of welding at least ¼" steel.
- Proper cutting tool (Grinder with cut off wheel, plasma cutter, cutting torch, etc.)
- Tape Measure
- Angle Finder

Bill of Materials			
QTY	Part Number	Etch Number	Description
1	B4W250826	826 B	JL Front Axle LCA Bracket Passenger
1	B4W250827	827 B	JL Front Axle LCA Bracket Driver

Step 1:

Park the Jeep on a level surface and remove the front lower control arms.

Step 2:

Measure the location of the OEM brackets on the axle. Make a note of these measurements the Barnes 4WD Jeep JL Front Axle lower control arm brackets will need to be in the same location as the OEM brackets.

Step 3:

Using the proper cutting tool remove the OEM front axle lower control arm brackets cutting in the locations shown below.



Step 4:

Place the new Barnes4wd lower control arm bracket on the axle in the same location as the old lower control arm bracket. The bracket should be 3 5/8" from the coil bucket and rotated 7° back from the diff cover.

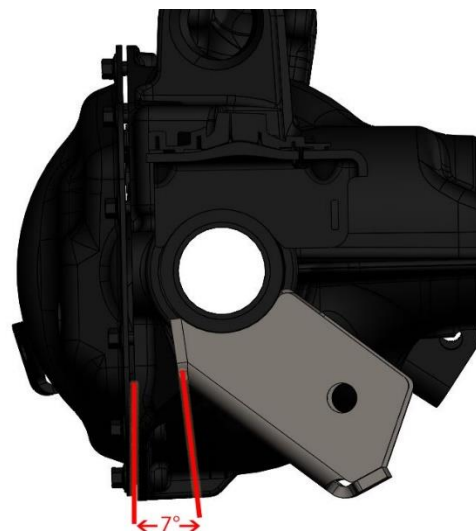
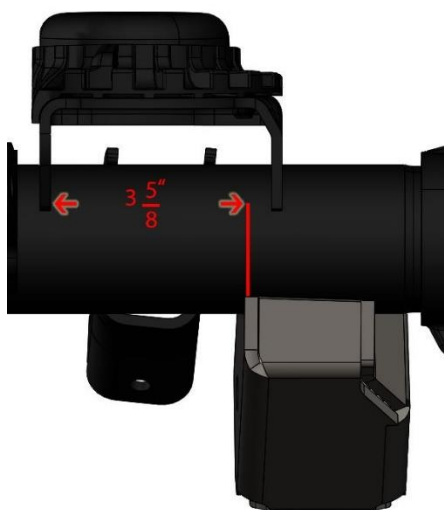

Step 5:

Tack the bracket into place and test fit the factory lower control arm into the bracket. Cycle the suspension to check for clearance issues.

Step 6:

Remove the factory lower control arm and fully weld the bracket together and to the axle.

Step 7:

Repeat Steps 1 through 6 on the opposite side of the jeep.

Congratulations! You have Completed Installation of your Barnes 4wd Jeep JL Front Axle Lower Control Arm Brackets

Professional Services Disclaimer:

The content of all pages of this website (collectively, the "Website"), such as text, graphics, images, information and other material (collectively, "Content") is for informational purposes only. Any information furnished on this Website is not intended nor implied to be automotive advice and is not intended to replace personal consultation with a qualified automotive service technician, mechanic, or similar automotive professional.

Barnes 4WD has not examined the Content for accuracy, timeliness, completeness, appropriateness, or helpfulness. Barnes 4WD does not endorse any specific tests, products, procedures, opinions, or other information that may be mentioned on this Website. Your reliance upon information and Content obtained by you at or through this Website is solely at your own risk. IN NO EVENT SHALL BARNES 4WD BE LIABLE OR OTHERWISE RESPONSIBLE FOR ANY DAMAGE OR INJURY (INCLUDING DEATH) TO YOU, OTHER PERSONS, OR PROPERTY ARISING FROM ANY USE OF ANY PRODUCT, INFORMATION, IDEA, OR INSTRUCTION CONTAINED IN THE CONTENT.

BARNES 4WD DOES NOT MAKE ANY REPRESENTATION OR WARRANTY, EXPRESS OR IMPLIED, AT LAW OR IN EQUITY, WITH RESPECT TO ANY PRODUCT FEATURED ON THE WEBSITE, INCLUDING WITHOUT LIMITATION WITH RESPECT TO MERCHANTABILITY, FITNESS FOR ANY PARTICULAR PURPOSE, VALUE, VALIDITY, OR ENFORCEABILITY, AND ANY AND ALL SUCH OTHER REPRESENTATIONS OR WARRANTIES ARE HEREBY EXPRESSLY DISCLAIMED.