

Jeep JK Superduty 1 Ton Dana 60 1999-Up Axle Swap Truss Kit 3
Link Upper Installation Instructions

Thank you for purchasing our Jeep JK Axle Truss Swap Kit!

Installation Notes:

- Installation of this kit requires a trained welder
- Refer to your factory service manual for information regarding the removal of any factory components
- This kit does not contain any provisions for the following items: ABS sensors, driveshaft modifications, and brake lines
- Installation of this kit requires custom lower control arms and a custom track bar
- This kit will raise the position of the coil springs 2". Shorter coil springs or longer shocks will need to be used to compensate for the difference.
- The casting on the Superduty axle will need to be trimmed and all factory bracketry removed
- This kit is designed to be used with a 3 link front suspension, with a single upper control arm

Tools required:

- Welding machine with the capability to weld at least 5/16" thick steel
- Various hand tools for the removal and installation of the factory suspension components
- Grinder
- Cutting torch, plasma cutter or other appropriate cutting tool
- Angle finder
- Tape measure

Step 1:

2005-Up Axles

The casting on the Dana 60 axle will need to be trimmed. The cast section of the radius arm bracket on the driver's side will need to be removed, as well as a short section of the casting where the tube enters the center section. See images below for the areas to trim. The end of the casting where the driver tube enters the center section will need to be trimmed back 2". After trimming the casting grind all edges smooth.

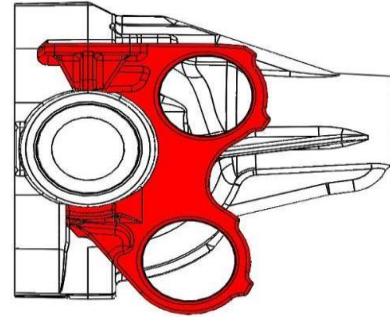
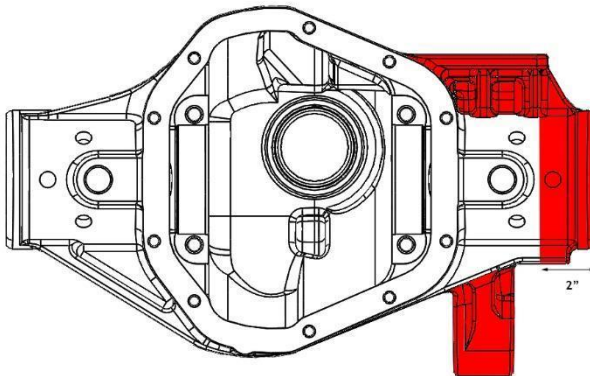

Your axle center section should look like the images below after trimming and grinding.

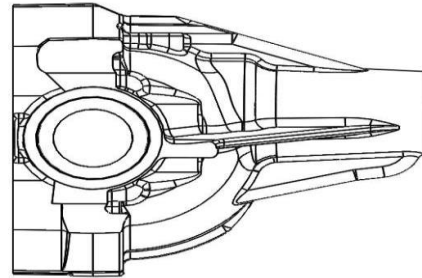
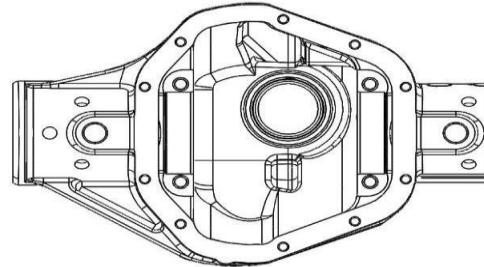

1999-2004 Axles

The casting on the driver's side short axle tube will need to be trimmed back 2". Additional trimming may be required on the webbing to provide clearance for the shock bracket.

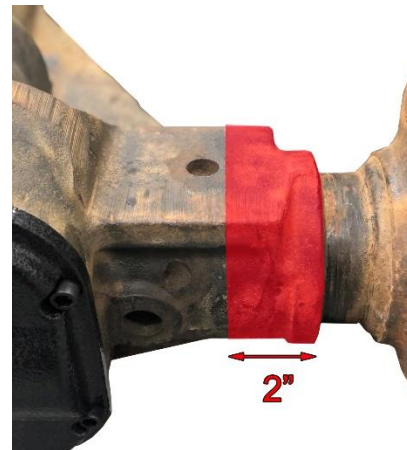

Step 2:

Remove any other factory bracketry on the axle. After removal is complete your axle should look like the image below.

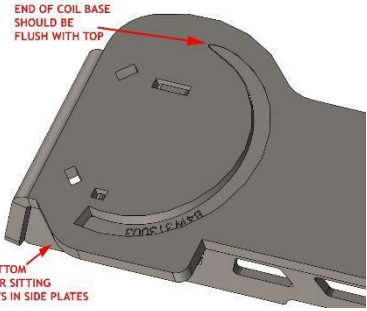

Step 3:

The inner C's on the 2005-Up Dana 60 axle will need to be trimmed in order to provide clearance for the JK coil springs. See the image below for the location to be trimmed. Trim both the passenger and drivers inner C's.

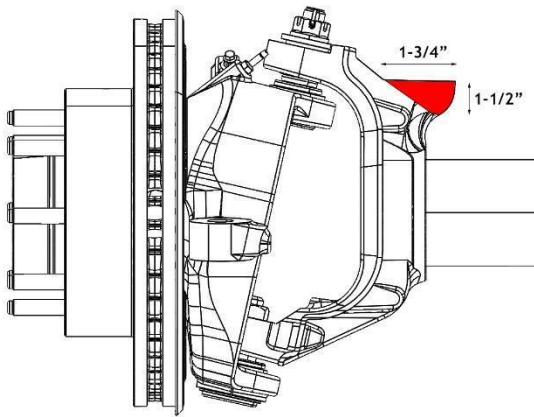

Step 4:

It is now time to start assembling the truss. The two side plates need to be attached to the truss top. The sides will key into the truss, and can only be inserted in the appropriate position and orientation. Once the sides are installed in the truss top, tack weld them in place.



Step 5:

Install the coil spring bases in the truss top on both sides. The small end of the base should be flush with the top of the truss, the large end will sit on top of the side plates. When installed correctly the bases will sit at an angle to follow the arc of the coil spring.

Step 6:

On both sides of the truss install the coil spring centers. The centers will tab into the top of the truss when located correctly. Once the coil centers are tabbed into the truss weld the inside of the truss top.

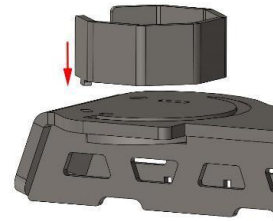

Step 7:

Install the caps on the coil spring centers on both sides. Weld along the seam where the cap joins the coil center. The tab on the side of the coil cap will locate it in the correct orientation.

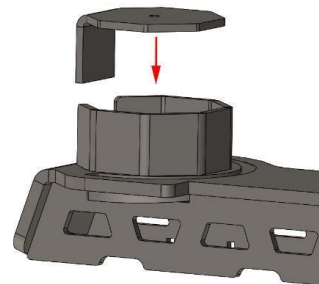

Step 8:

Place the upper control arm mounting bracket on top of the truss. Using the slots in the truss top align the inside edge of the bracket with the back edge of the slots. Also position the bracket so it is centered between the slots and weld in place.

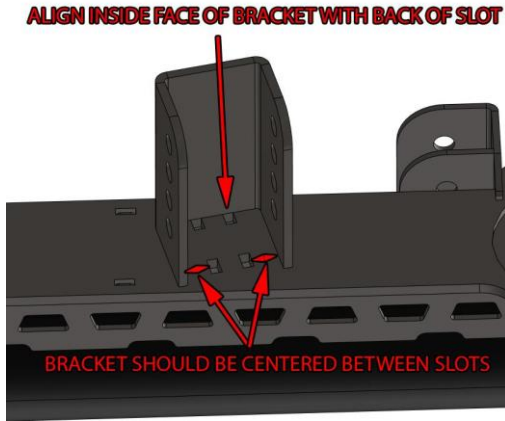

Step 9:

Place the truss assembly on the Dana 60 and rotate back 7° in relation to the differential cover mounting face. The easiest way to achieve this is to place a level on the differential cover mounting surface and rotate the axle until level (perpendicular to the ground). Place an angle finder on the top of the truss and rotate the truss back until an angle of 7° is achieved. Measure from both ends and center the truss on the axle, tack weld the truss in place. Some grinding on the welds on the inner c's may be required for the truss to sit down completely on the axle.

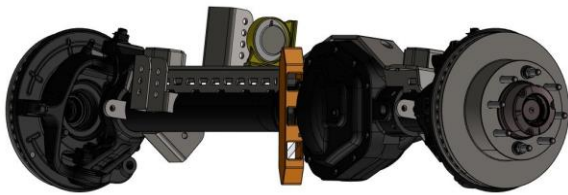

Step 10:

Install the shock brackets on both sides of the axle. The shock tabs will key into the sides of the truss. Insert the shock brackets in the slots and rotate until the small flats on the tabs are parallel with the face of the truss side weld in place. Repeat this step for the other shock bracket.

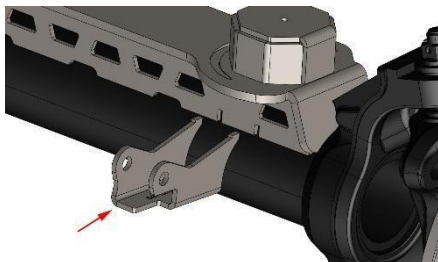

Step 11:

The lower control arm mounting brackets now need to be installed. The control arm brackets will tab into the bottom of the shock brackets. After the lower control arm bracket is positioned correctly weld it in place. Repeat this procedure for the opposite side. Some grinding at the welds on the inner c's may be required for proper fitment.

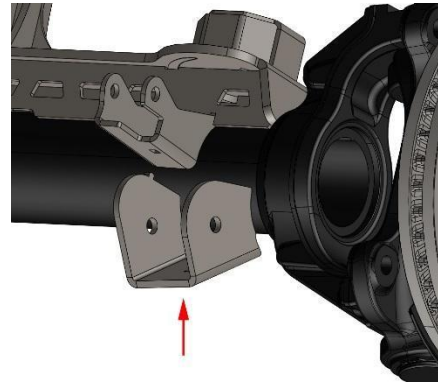

Step 12:

Assemble the track bar bracket. The track bar bracket consists of two parts. The parts will key together, see the images below for assembly of the two parts. Tack weld the two parts together. Take care to make sure the two sides remain parallel while welding.

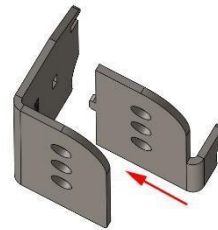

Step 13:

Place the track bar bracket assembly on the truss, the cut-out in the bracket will slide over the truss top and down the truss until it contacts the area where the coil spring sits.

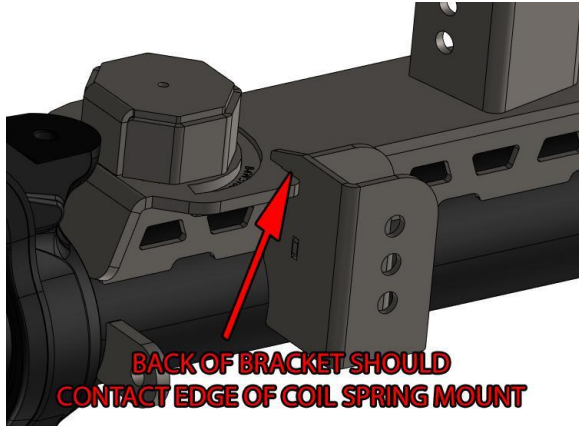

the bracket. Assemble the two halves of the bracket, and place the assembly against the bottom of the frame and center the steering box bolt hole in the hole on the bracket and tack weld in place. The bracket will work with most aftermarket adjustable track bars, however we recommend fully cycling the suspension, and checking for clearance to all components before fully welding into place.

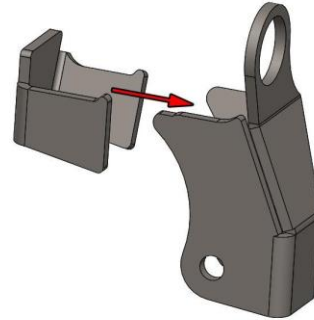

Step 14:

Install sway bar mounting tabs. The sway bar mounting tabs will weld to the axle tube on either end of the axle. They should be located $\frac{1}{2}$ " from the inside edge of the inner C and the top should be parallel with the truss top. Repeat the procedure for the opposite side.



Congratulations!

Your axle is now ready to be installed in your Jeep. The lower control arm brackets on this kit have been moved outward due to the size of the casting. Your existing lower control arms will need to be modified, or custom lower control arms will need to be fabricated.

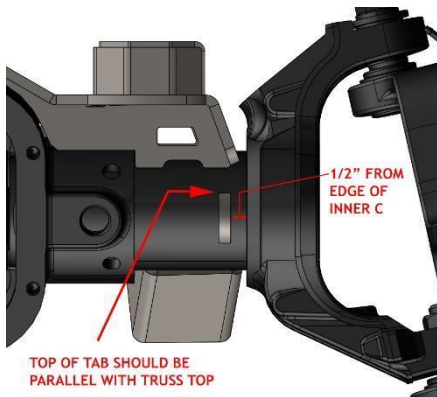

Step 15:

Finish weld any areas that were tacked in the previous steps. It is not necessary to weld all seams completely, make small staggered welds and do not concentrate heat in one area any more than necessary.

Step 16:

A new front track bar bracket is included with the kit. The track bar bracket uses the front bottom steering box bolt hole to locate

Professional Services Disclaimer:

The content of this Website, such as text, graphics, images, information and other material (collectively, "Content") is for informational purposes only. Any information furnished on this Website is not intended nor implied to be automotive advice and is not intended to replace personal consultation with a qualified automotive service technician, mechanic or similar automotive professional.

Barnes 4WD has not examined the Content for accuracy, timeliness, completeness, appropriateness, or helpfulness. Barnes 4WD does not endorse any specific tests, products, procedures, opinions, or other information that may be mentioned on this Website. Your reliance upon information and Content obtained by you at or through this Website is solely at your own risk. IN NO EVENT SHALL BARNES 4WD BE LIABLE OR OTHERWISE RESPONSIBLE FOR ANY DAMAGE OR INJURY (INCLUDING DEATH) TO YOU, OTHER PERSONS, OR PROPERTY ARISING FROM ANY USE OF ANY PRODUCT, INFORMATION, IDEA, OR INSTRUCTION CONTAINED IN THE CONTENT.