

Jeep JK GM 14 Bolt Axle Truss Swap Kit

Thank you for purchasing your new Jeep JK Axle Swap Kit!

Installation Notes:

- Installation of this kit requires welding
- Refer to your factory service manual for information regarding the removal of any O.E.M. components
- This kit does not contain any provisions for the following items: ABS sensors, driveshaft modifications, and brake lines
- This kit requires a 14 bolt with a WMS-WMS of at least 68". This axle is found in 1999-2006 GM 2500 and 3500 single rear wheel trucks. This is the newer style "ribbed" housing, this kit will not work with the older 14 bolt housing.
- Bolts and nuts have been provided for the upper control arms. This is a very tight fit between the end of the bolt and the caliper bracket. Depending on your axle a slight amount of grinding may be required for clearance for the bolt and nut.

Tools required:

- Welding machine with the capability to weld at least 1/4" thick steel
- Various hand tools for the removal and installation of factory suspension components
- Grinder
- Cutting torch, plasma cutter or other appropriate cutting tool
- Angle finder
- Tape measure

Step 1:

Remove all factory brackets from the 14 bolt axle, none of the factory bracketry will be used.

Step 2:

Place the axle on jack stands or another sturdy work surface. Rotate the axle until the desired pinion angle for your Jeep is achieved. Place the truss top on the axle and level (parallel to the ground). Measure from the backing plate flanges to the ends of the truss, and center the truss on the axle. Once truss is positioned properly, place tack welds to secure it to the axle tubes.

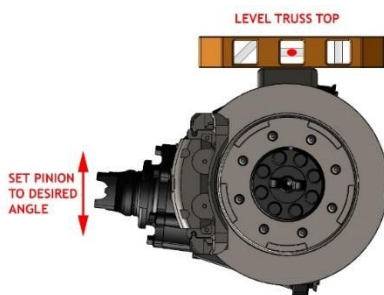

Step 3:

The included 3/8" nuts will need to be welded to the coil spring caps. Center the nut in the hole on the cap and weld in place. Repeat this for both caps.

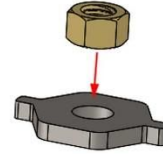

Step 4:

Install the coil spring locator and cap assembly on the truss. There are two locators per side, they will go in the hex shaped holes in the top of the truss. The coil cap will then key into the locators. Once positioned properly, weld into place.

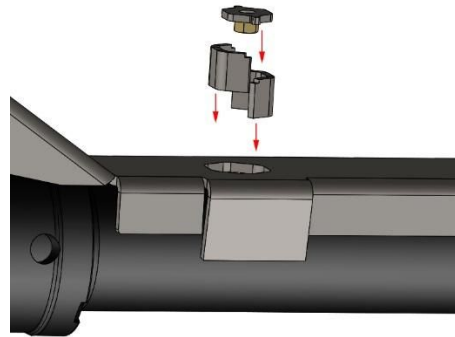

Step 5:

Assemble the two halves of the track bar bracket. The two pieces will key together, take care during assembly to keep the two halves parallel and at the correct mounting width. Once the two pieces have been assembled weld them together.

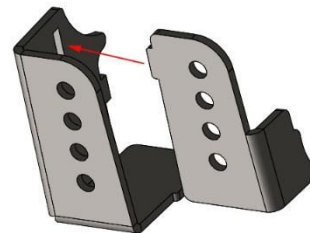

Standard Lower Control Arm Bracket Assembly instructions:

Step 6:

Place the track bar assembly on the truss. The bracket is keyed to fit in a slot on the back of the truss. Once the bracket has been placed correctly on the truss, weld in place.

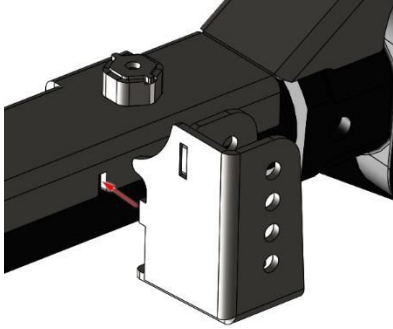

Step 7:

The upper control arm bracket will now need to be installed. The bracket will key into a slot in the top of the truss. Gussets have been provided to go on either side of the bracket. The gussets will angle back towards the rear of the truss. Once properly positioned weld into place, and repeat for the other side.

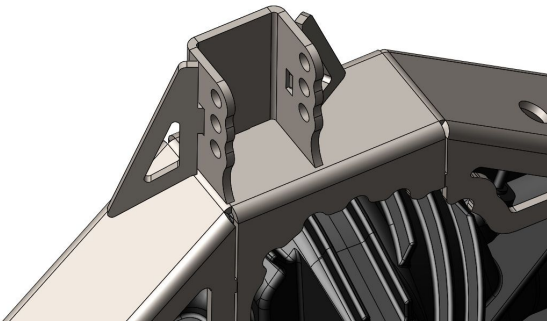

Step 8:

The lower control arm brackets need to be assembled. You have two options when assembling the brackets, a high clearance option and a standard option. The high clearance option will require 2" shorter shocks, the standard option will work with your existing shocks. Skip to the appropriate section below for the configuration you would like to use for your install.

Step 1:

Place the shock bracket in the lowest slot on the lower control arm bracket and weld it in place.

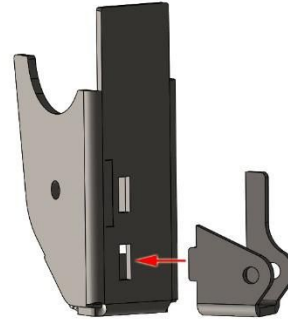

Step 2:

The lower control arm bracket will have an etch mark for the location of the sway bar tab. Using the etch mark as a guide place the sway bar tab and weld in place.

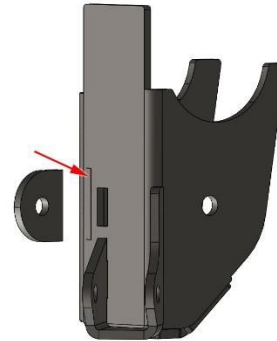

High Clearance Lower Control Arm Bracket Assembly Instructions.

Step 1:

The lower control arm bracket will need to be trimmed for this option. Measure up 2" from the bottom of the bracket and trim all the way around.

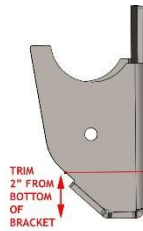

Step 2:

Place the skid plate in the bottom of the bracket, line up the edges and weld into place.

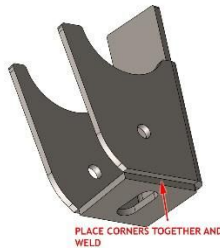

Step 3:

Install the shock bracket in the upper slot on the lower control arm bracket, and weld in place.



Step 4:

The lower control arm bracket will have an etch mark for the location of the sway bar tab. Using the etch mark as a guide place the sway bar tab and weld in place.

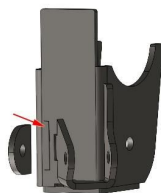

Step 9:

Install the lower control arm bracket assemblies on the axle. The brackets will need to angle in towards the pinion of the axle. Place the tab on the top of the lower control arm in the cut out on the backside of the truss top. Rotate the bracket until it contacts the top edge of the truss inside the cut out. Weld the bracket in place and repeat for the other side.

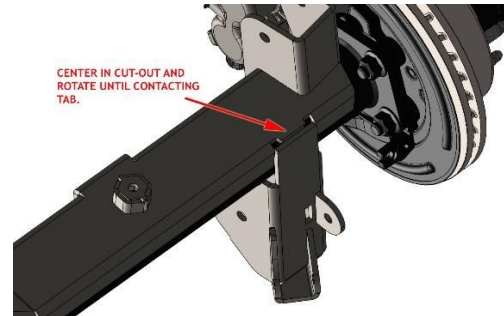

Step 10:

Weld the truss to the axle, and weld all seams not welded in previous steps. It is not necessary to weld the truss to the axle in all areas of contact. We recommend making staggered welds, weld a 1"-2" long weld, skip an area about the same length, and add another weld. We also recommend moving around on the axle while welding to avoid concentrating heat in one area. Take your time and allow plenty of time for the assembly to cool between welds.

Hardware note:

Hardware has been provided for the upper control arm at the axle. Coil retainers and bolts have also been provided. Both will need to be installed when the axle is placed in the Jeep.

Congratulations you have completed the installation of your JK one ton axle swap truss!

Professional Services Disclaimer:

The content of this Website, such as text, graphics, images, information and other material (collectively, "Content") is for informational purposes only. Any information furnished on this Website is not intended nor implied to be automotive advice and is not intended to replace personal consultation with a qualified automotive service technician, mechanic or similar automotive professional.

Barnes 4WD has not examined the Content for accuracy, timeliness, completeness, appropriateness, or helpfulness. Barnes 4WD does not endorse any specific tests, products, procedures, opinions, or other information that may be mentioned on this Website. Your reliance upon information and Content obtained by you at or through this Website is solely at your own risk. IN NO EVENT SHALL BARNES 4WD BE LIABLE OR OTHERWISE RESPONSIBLE FOR ANY DAMAGE OR INJURY (INCLUDING DEATH) TO YOU, OTHER PERSONS, OR PROPERTY ARISING FROM ANY USE OF ANY PRODUCT, INFORMATION, IDEA, OR INSTRUCTION CONTAINED IN THE CONTENT.