



JT Passenger Bed Molle Panel Installation Instructions

Thank you for purchasing our JT Passenger Bed Molle Panel!

Installation Notes:

- All Hardware is stainless steel to prevent corrosion. Hardware will need installed by hand with antiseize to prevent galling.
- These Molle Panels are designed to fit a 2020-Current Jeep Gladiator JT.
- Refer to your factory service manual when removing any factory components.
- The Molle Panels will work with the Mopar Trail Rail PN: 82215956 with slight modification.
- The Molle Panels will need to be painted or powder coted before installation we recommend you test fit the panels before painting.

Tools required:

- 3/8" Ratchet
- 1/4" Ratchet
- 4" Extension
- 4MM Allen Socket
- 7/32" Allen Socket
- 5/32" Allen Socket
- 7/16" Wrench
- Antiseize

Optional Tools if using Mopar Trail Rail

- T30 Socket
- Drill
- 3/8" Drill Bit

Contents of box

Bill Of Materials for B4WK12673			
QTY	Part Number	Etch Number	Description
1	B4W125090	090 B	JT Passenger Rear Bed Molle Panel
1	B4W125091	091 B	JT Passenger Front Bed Molle Panel
1	B4W125092	092	JT Bed Side Molle Panel Connector
1	B4W075044	044 B	JT Bed Side Molle Panel Bracket
7	25C62KBC3	NA	1/4"-20 X 5/8 Button Head Cap Screw Stainless
7	25CNNES	NA	1/4-20 Nylock Stainless
1	37C100KBCS	NA	3/8"-16 x 1" Button Head Socket Cap Screw Stainless
1	CHANNELNUT0375Z	NA	Channel Nut 3/8-16
4	.60C140KBC/A27380	NA	M6-1X 14MM Button Head Screw

Step 1:

If the Jeep is equipped with the Mopar Trail Rail remove the passenger side. If the Jeep is not equipped with the trail rail skip to step 3.

Step 2:

Drill the plastic tab on the trail rail out to a 3/8" hole as shown below.



Step 3:

Assemble the molle panels as shown below and tighten hardware.

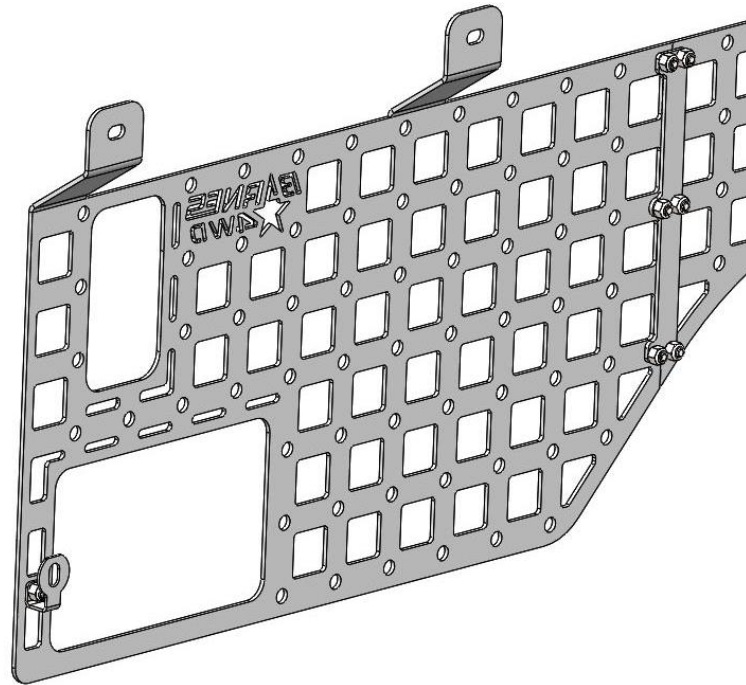

Step 4:

Non-Trail Rail

Install the molle panel assembly on to the JT bed as shown below. Use the supplied m6 bolts to install the panel to the bed. The threads in the bed may need to be chased with a tap if they have never been used. The tap size is M6X1.

Trail Rail

Install the molle panel assembly and the trail rail at the same time. Reuse the factory hardware.

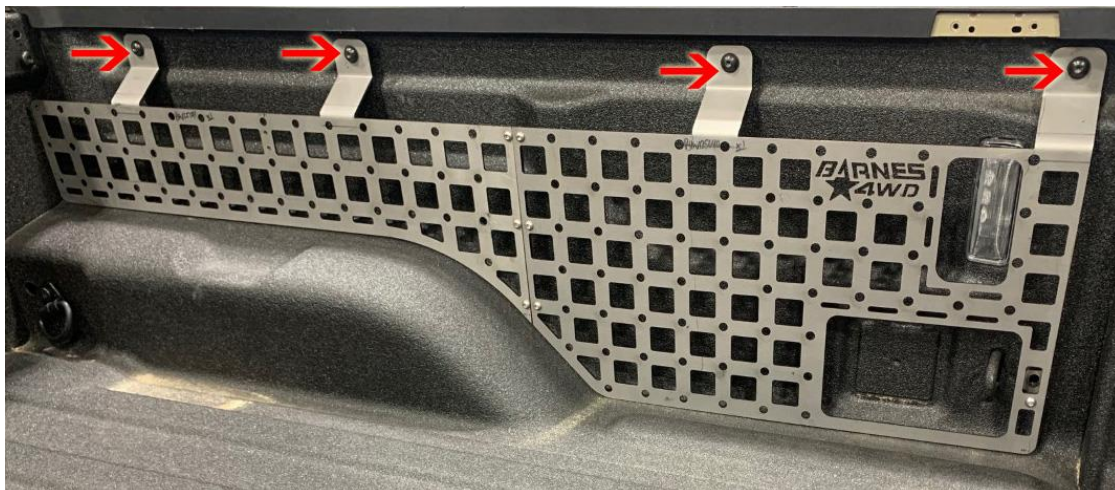

Step 5:

From underneath the bed, install the supplied channel nut. Install the 3/8" hardware through the panel bracket as shown below.



Congratulations! You Have finished the installation of the Barnes4wd JT Passenger Molle Panel.

Professional Services Disclaimer:

The content of all pages of this website (collectively, the "Website"), such as text, graphics, images, information and other material (collectively, "Content") is for informational purposes only. Any information furnished on this Website is not intended nor implied to be automotive advice and is not intended to replace personal consultation with a qualified automotive service technician, mechanic, or similar automotive professional.

Barnes 4WD has not examined the Content for accuracy, timeliness, completeness, appropriateness, or helpfulness. Barnes 4WD does not endorse any specific tests, products, procedures, opinions, or other information that may be mentioned on this Website. Your reliance upon information and Content obtained by you at or through this Website is solely at your own risk. IN NO EVENT SHALL BARNES 4WD BE LIABLE OR OTHERWISE RESPONSIBLE FOR ANY DAMAGE OR INJURY (INCLUDING DEATH) TO YOU, OTHER PERSONS, OR PROPERTY ARISING FROM ANY USE OF ANY PRODUCT, INFORMATION, IDEA, OR INSTRUCTION CONTAINED IN THE CONTENT.

BARNES 4WD DOES NOT MAKE ANY REPRESENTATION OR WARRANTY, EXPRESS OR IMPLIED, AT LAW OR IN EQUITY, WITH RESPECT TO ANY PRODUCT FEATURED ON THE WEBSITE, INCLUDING WITHOUT LIMITATION WITH RESPECT TO MERCHANTABILITY, FITNESS FOR ANY PARTICULAR PURPOSE, VALUE, VALIDITY, OR ENFORCEABILITY, AND ANY AND ALL SUCH OTHER REPRESENTATIONS OR WARRANTIES ARE HEREBY EXPRESSLY DISCLAIMED.



JT Front Bed Molle Panel Installation Instructions

Thank you for purchasing our JT Front Bed Molle Panel!

Installation Notes:

- All Hardware is stainless steel to prevent corrosion. Hardware will need installed by hand with antiseize to prevent galling.
- These Molle Panels are designed to fit a 2020-Current Jeep Gladiator JT.
- Refer to your factory service manual when removing any factory components.
- The Molle Panels will work with the Mopar Trail Rail PN: 82215956.
- The Molle Panels will need to be painted or powder coted before installation we recommend you test fit the panels before painting.

Tools required:

- 3/8" Ratchet
- 1/4" Ratchet
- 4" Extension
- 4MM Allen Socket
- 5/32" Allen Socket
- 7/16" Wrench
- T30 Socket
- T45 Socket
- Antiseize

Contents of box

Bill Of Materials for B4WK12675			
QTY	Part Number	Etch Number	Description
1	B4W125095	095 B	JT Bed Molle Panel Front Driver
1	B4W125094	094 B	JT Bed Molle Panel Front Passenger
1	B4W125096	096	JT Bed Molle Panel Front Connector
6	25C62KBC3	NA	1/4"-20 X 5/8 Button Head Cap Screw Stainless
6	25CNNES	NA	1/4-20 Nylock Stainless
4	.60C140KBC/A27380	NA	M6-1X 14MM Button Head Screw

Step 1:

If the Jeep is equipped with the Mopar Trail Rail remove the front rail.

Step 2:

Remove the factory cargo hooks from the bed as shown below.



Step 3:

Assemble the molle panels as shown below and tighten hardware.

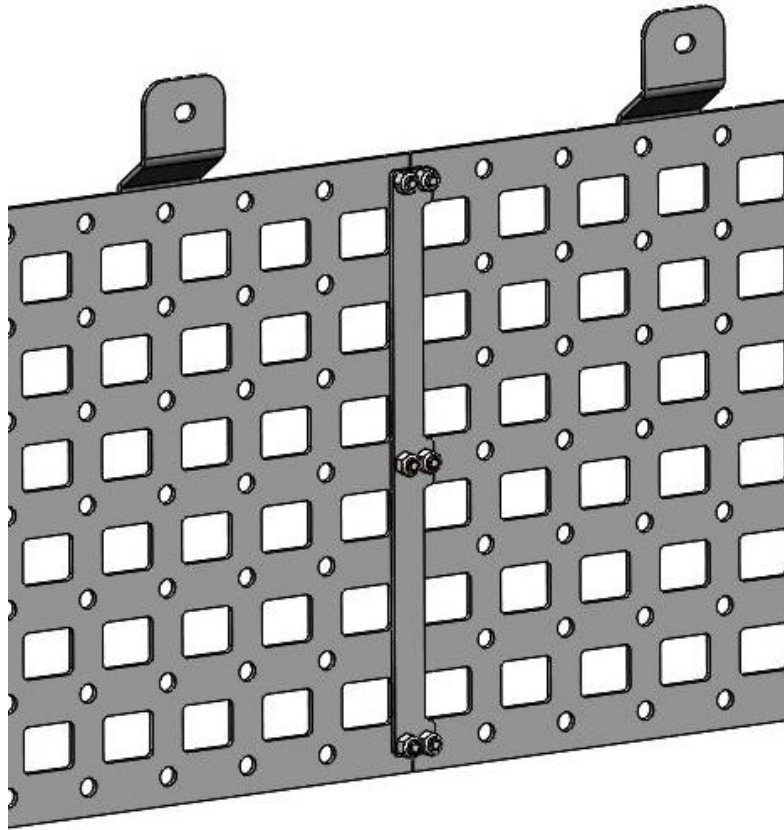

Step 4:

Non-Trail Rail

Install the molle panel assembly on to the JT bed as shown below. Use the supplied m6 bolts to install the panel to the bed. The threads in the bed may need to be chased with a tap if they have never been used. The tap size is M6X1.

Trail Rail

Install the molle panel assembly and the trail rail at the same time. Reuse the factory hardware.

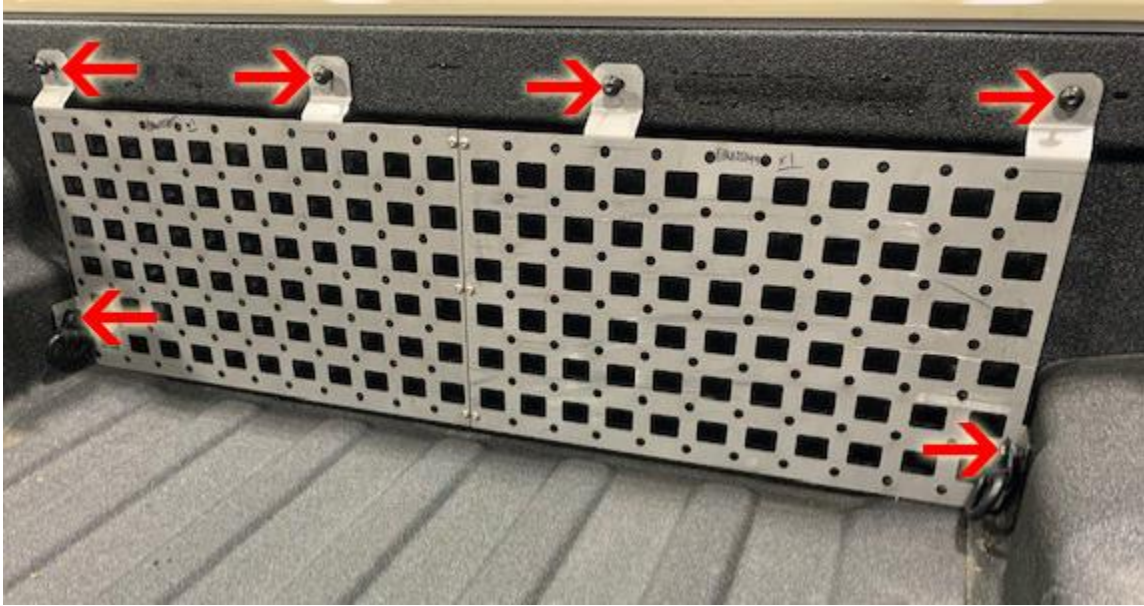

Congratulations! You Have finished the installation of the Barnes4wd JT Front Molle Panel.

Professional Services Disclaimer:

The content of all pages of this website (collectively, the "Website"), such as text, graphics, images, information and other material (collectively, "Content") is for informational purposes only. Any information furnished on this Website is not intended nor implied to be automotive advice and is not intended to replace personal consultation with a qualified automotive service technician, mechanic, or similar automotive professional.

Barnes 4WD has not examined the Content for accuracy, timeliness, completeness, appropriateness, or helpfulness. Barnes 4WD does not endorse any specific tests, products, procedures, opinions, or other information that may be mentioned on this Website. Your reliance upon information and Content obtained by you at or through this Website is solely at your own risk. IN NO EVENT SHALL BARNES 4WD BE LIABLE OR OTHERWISE RESPONSIBLE FOR ANY DAMAGE OR INJURY (INCLUDING DEATH) TO YOU, OTHER PERSONS, OR PROPERTY ARISING FROM ANY USE OF ANY PRODUCT, INFORMATION, IDEA, OR INSTRUCTION CONTAINED IN THE CONTENT.

BARNES 4WD DOES NOT MAKE ANY REPRESENTATION OR WARRANTY, EXPRESS OR IMPLIED, AT LAW OR IN EQUITY, WITH RESPECT TO ANY PRODUCT FEATURED ON THE WEBSITE, INCLUDING WITHOUT LIMITATION WITH RESPECT TO MERCHANTABILITY, FITNESS FOR ANY PARTICULAR PURPOSE, VALUE, VALIDITY, OR ENFORCEABILITY, AND ANY AND ALL SUCH OTHER REPRESENTATIONS OR WARRANTIES ARE



JT Driver Bed Molle Panel Installation Instructions

Thank you for purchasing our JT Driver Bed Molle Panel!

Installation Notes:

- **All Hardware is stainless steel to prevent corrosion. Hardware will need installed by hand with antiseize to prevent galling.**
- These Molle Panels are designed to fit a 2020-Current Jeep Gladiator JT.
- Refer to your factory service manual when removing any factory components.
- The Molle Panels will work with the Mopar Trail Rail PN: 82215956 with slight modification.
- The Molle Panels will need to be painted or powder coted before installation we recommend you test fit the panels before painting.

Tools required:

- 3/8" Ratchet
- 1/4" Ratchet
- 4" Extension
- 4MM Allen Socket
- 7/32" Allen Socket
- 5/32" Allen Socket
- 7/16" Wrench
- Antiseize

Optional Tools if using Mopar Trail Rail

- T30 Socket
- Drill
- 3/8" Drill Bit

Contents of box

Bill Of Materials for B4WK12674			
QTY	Part Number	Etch Number	Description
1	B4W125098	098 B	JT Driver Rear Bed Molle Panel
1	B4W125097	097 B	JT Driver Front Bed Molle Panel
1	B4W125092	092	JT Bed Side Molle Panel Connector
1	B4W075044	044 B	JT Bed Side Molle Panel Bracket
7	25C62KBC3	NA	1/4"-20 X 5/8 Button Head Cap Screw Stainless
7	25CNNES	NA	1/4-20 Nylock Stainless
1	37C100KBCS	NA	3/8"-16 x 1" Button Head Socket Cap Screw Stainless
1	CHANNELNUT0375Z	NA	Channel Nut 3/8-16
4	.60C140KBC/A27380	NA	M6-1X 14MM Button Head Screw

Step 1:

If the Jeep is equipped with the Mopar Trail Rail remove the driver side. If the Jeep is not equipped with the trail rail skip to step 3.

Step 2:

Drill the plastic tab on the trail rail out to a 3/8" hole as shown below.



Step 3:

Assemble the molle panels as shown below and tighten hardware.

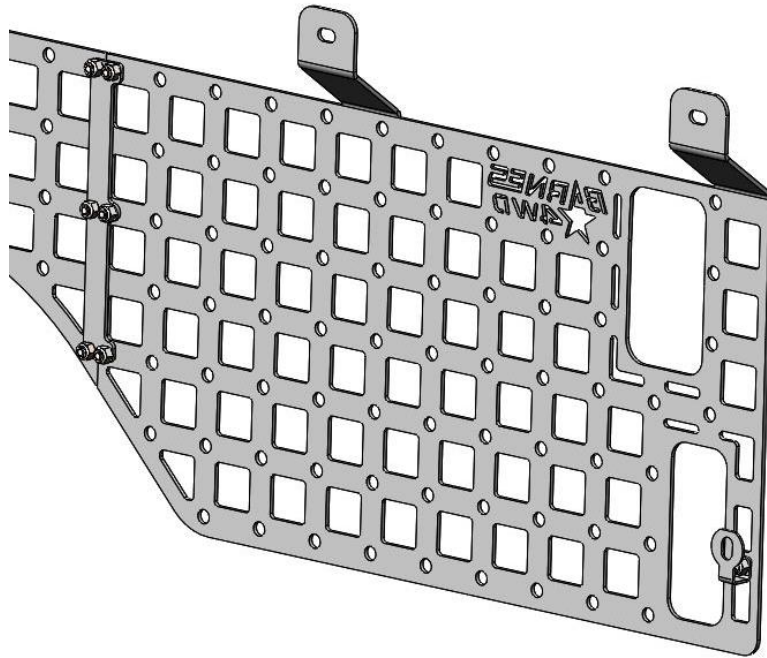

Step 4:

Non-Trail Rail

Install the molle panel assembly on to the JT bed as shown below. Use the supplied m6 bolts to install the panel to the bed. The threads in the bed may need to be chased with a tap if they have never been used. The tap size is M6X1.

Trail Rail

Install the molle panel assembly and the trail rail at the same time. Reuse the factory hardware.

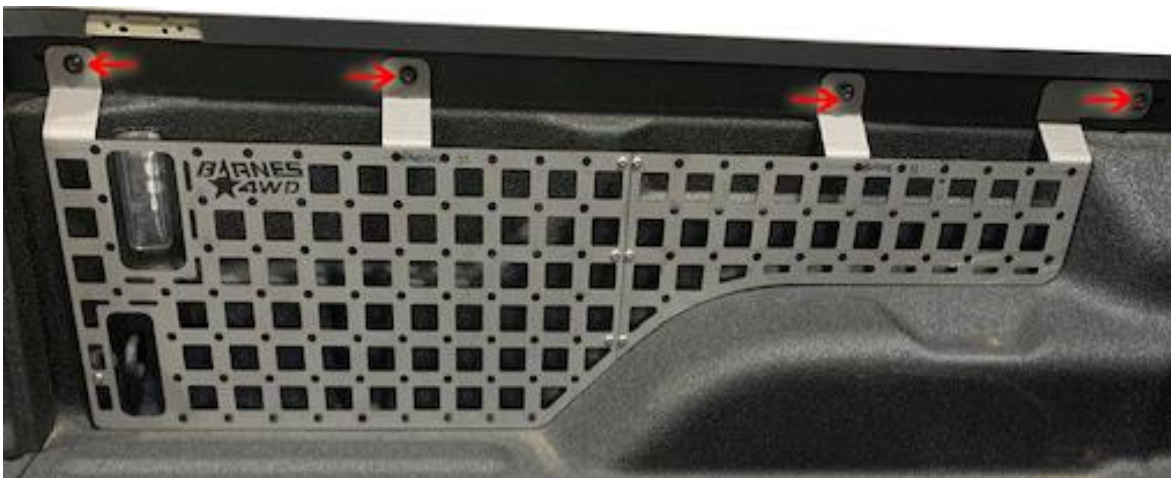

Step 5:

From underneath the bed, install the supplied channel nut. Install the 3/8" hardware through the panel bracket as shown below.



Congratulations! You Have finished the installation of the Barnes4wd JT Driver Molle Panel.

Professional Services Disclaimer:

The content of all pages of this website (collectively, the "Website"), such as text, graphics, images, information and other material (collectively, "Content") is for informational purposes only. Any information furnished on this Website is not intended nor implied to be automotive advice and is not intended to replace personal consultation with a qualified automotive service technician, mechanic, or similar automotive professional.

Barnes 4WD has not examined the Content for accuracy, timeliness, completeness, appropriateness, or helpfulness. Barnes 4WD does not endorse any specific tests, products, procedures, opinions, or other information that may be mentioned on this Website. Your reliance upon information and Content obtained by you at or through this Website is solely at your own risk. IN NO EVENT SHALL BARNES 4WD BE LIABLE OR OTHERWISE RESPONSIBLE FOR ANY DAMAGE OR INJURY (INCLUDING DEATH) TO YOU, OTHER PERSONS, OR PROPERTY ARISING FROM ANY USE OF ANY PRODUCT, INFORMATION, IDEA, OR INSTRUCTION CONTAINED IN THE CONTENT.

BARNES 4WD DOES NOT MAKE ANY REPRESENTATION OR WARRANTY, EXPRESS OR IMPLIED, AT LAW OR IN EQUITY, WITH RESPECT TO ANY PRODUCT FEATURED ON THE WEBSITE, INCLUDING WITHOUT LIMITATION WITH RESPECT TO MERCHANTABILITY, FITNESS FOR ANY PARTICULAR PURPOSE, VALUE, VALIDITY, OR ENFORCEABILITY, AND ANY AND ALL SUCH OTHER REPRESENTATIONS OR WARRANTIES ARE HEREBY EXPRESSLY DISCLAIMED.