



## Jeep JL/JT Front Axle Disconnect Block Off Plate and Reinforcement Bracket Kit Installation Instructions

Thank you for purchasing this product!

### Installation Notes:

- This kit will require the installation of an aftermarket one-piece axle shaft for the passenger side or a space that locks the two factory shafts together.
- When installing the reinforcement bracket, you will be welding the bracket to your axle tubes and lower control arm bracket.
- The Jeep will have to be programmed to get rid of the CEL when the Front Axle Disconnect Actuator is disconnected.

### Tools required:

- Welder capable of welding 1/4" material
- Grinder with flap disc
- 5mm Hex Drive
- 13mm Socket and Ratchet

## Contents of each box

Bill Of Materials For B4WK12852- JL/JT FAD Block Off and Reinforcement Bracket Kit			
QTY	Part Number	Etch Number	Description
1	B4W125198	198	JL/JT FAD Block Off Plate
1	B4W250A57	A57	JL/JT FAD Reinforcement Bracket
2	.80C200KFC/7991	N/A	M8-1.25X20 Flat Head

### Step 1:

Unplug the front axle disconnect actuator and relocate the wiring harness up out of the way. It will no longer be needed. Remove any FAD skid if equipped.

### Step 2:

Using the 13mm socket, remove the four bolts holding the FAD actuator on the axle. Carefully remove the actuator from the axle. Retain the factory hardware, it will be reused. Go ahead and paint or powder coat the block off plate. Check the gasket on the axle, replace it if needed.

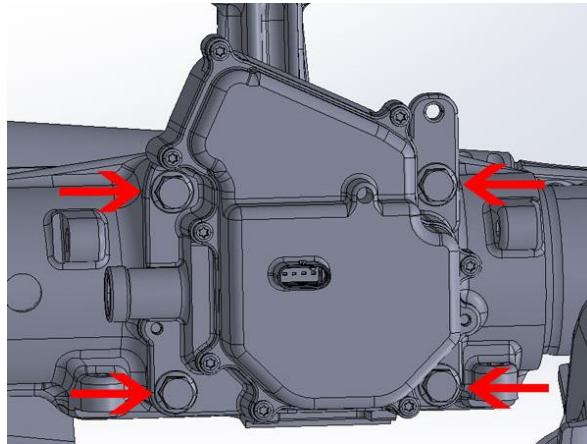

### Step 3:

Clean off the sealing surface on the axle and place the block off plate in place of the actuator. If you do not have the reinforcement bracket, use the factory hardware and install the block off plate. Fully tighten the hardware.



## Step 4: Reinforcement Bracket Installation

With the block off plate on the axle, place the reinforcement bracket over top of the block off plate. Make sure all the bolt holes line up and mark on the axle tubes and lower control arm bracket where the bracket touches these areas.

Note: If you have our lower control arm brackets installed, you will need to trim the reinforcement bracket so it fits around the replacement control arm bracket.



## Step 5:

Remove the reinforcement bracket and clean up the areas on the axle tubes and lower control arm bracket with the grinder. Paint just the inside of the reinforcement bracket at this time.

## Step 6:

Using the provided M8 hardware and the factory hardware from the actuator, install the reinforcement bracket over top the block off plate. Fully tighten the factory hardware then the M8 hardware.



## **Step 7:**

Fully weld the bracket together and then fully weld the bracket to the axle tube and lower control arm bracket. Removing the lower control arm bolt may be necessary.

## **Step 8:**

Paint the reinforcement bracket and any bare surface on the axle tubes and lower control arm bracket.

# **Congratulations! You have completed the installation of the Barnes 4WD JL/JT FAD Block Off Plate and Reinforcement Bracket!**

### Professional Services Disclaimer:

The content of all pages of this website (collectively, the "Website"), such as text, graphics, images, information and other material (collectively, "Content") is for informational purposes only. Any information furnished on this Website is not intended nor implied to be automotive advice and is not intended to replace personal consultation with a qualified automotive service technician, mechanic, or similar automotive professional.

Barnes 4WD has not examined the Content for accuracy, timeliness, completeness, appropriateness, or helpfulness. Barnes 4WD does not endorse any specific tests, products, procedures, opinions, or other information that may be mentioned on this Website. Your reliance upon information and Content obtained by you at or through this Website is solely at your own risk. IN NO EVENT SHALL BARNES 4WD BE LIABLE OR OTHERWISE RESPONSIBLE FOR ANY DAMAGE OR INJURY (INCLUDING DEATH) TO YOU, OTHER PERSONS, OR PROPERTY ARISING FROM ANY USE OF ANY PRODUCT, INFORMATION, IDEA, OR INSTRUCTION CONTAINED IN THE CONTENT.

BARNES 4WD DOES NOT MAKE ANY REPRESENTATION OR WARRANTY, EXPRESS OR IMPLIED, AT LAW OR IN EQUITY, WITH RESPECT TO ANY PRODUCT FEATURED ON THE WEBSITE, INCLUDING WITHOUT LIMITATION WITH RESPECT TO MERCHANTABILITY, FITNESS FOR ANY PARTICULAR PURPOSE, VALUE, VALIDITY, OR ENFORCEABILITY, AND ANY AND ALL SUCH OTHER REPRESENTATIONS OR WARRANTIES ARE HEREBY EXPRESSLY DISCLAIMED.