

## JKU Skid Plate Installation Instructions

Thank you for purchasing our JKU skid plate kit!

### Installation Notes:

- A factory service manual is recommended for reference to remove any factory components.

### Tools Required:

- Jack
- 14mm Socket
- Ratchet
- Extension
- $\frac{3}{4}$ " Socket
- $\frac{3}{4}$ " Wrench

### Step 1:

Remove the factory transfer case and transmission skid plate. Retain all hardware, it will be reused later in the installation.

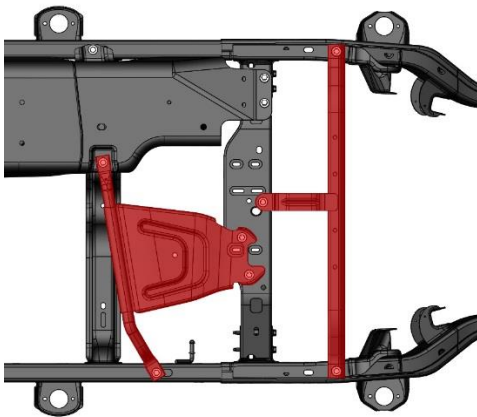

### Step 2:

Place the flag nuts inside the cross-member over the proper holes, the flag nuts need to be installed with the flat side down. See images below to determine the proper locations for your year model Jeep. Slide the flag nuts in the large holes in the side of the crossmember on both sides and position over the correct hole for your application.

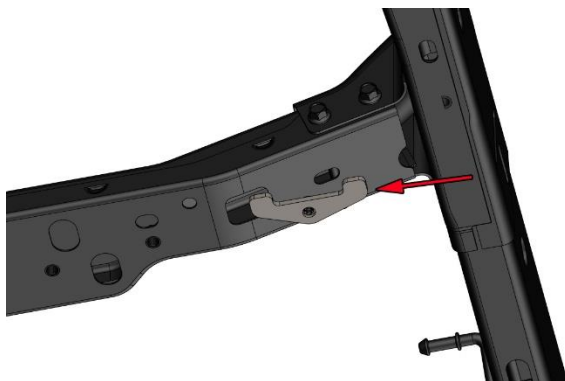

### 2007-2011 JKU

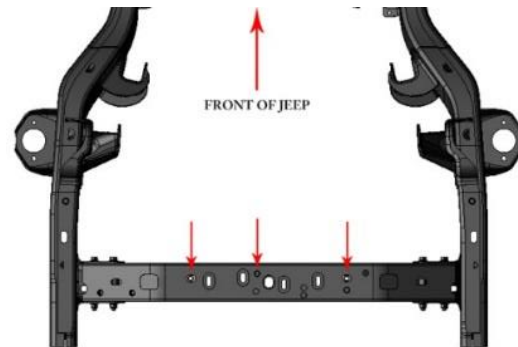

### 2012-PRESENT JKU

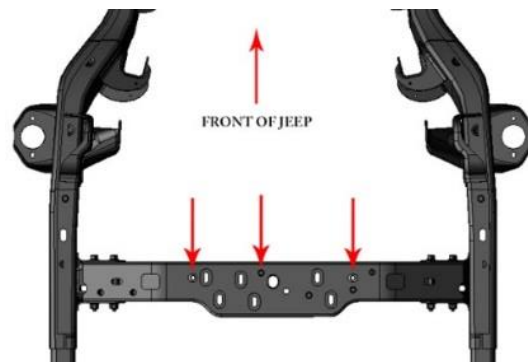

### Step 3:

Support the transmission with a jack under the transmission pan. Use a piece of wood to evenly distribute that load on the pan, to prevent damage to the pan.

### Step 4:

Remove the 4 long bolts that attach the cross-member to the frame, move the jack up or down to relieve tension on the bolts to make them easier to remove. The hardware removed in this step will not be reused.

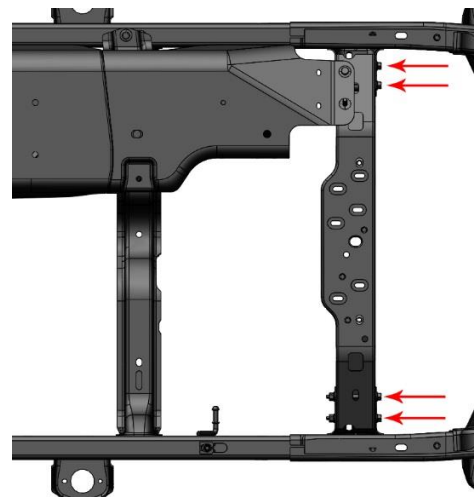

Step 5:

Lift the transfer case skid into place, and install the 4 included 12mm bolts, washers, and lock nuts. Place a washer under the head of the bolt and a washer under the locknut during installation. Do not tighten the hardware at this time.

Pro Tip:

The nuts and washers on the driver's side of the Jeep can be difficult to access. It is helpful to have another person to help install the nuts and washers from the rear of the skid plate.

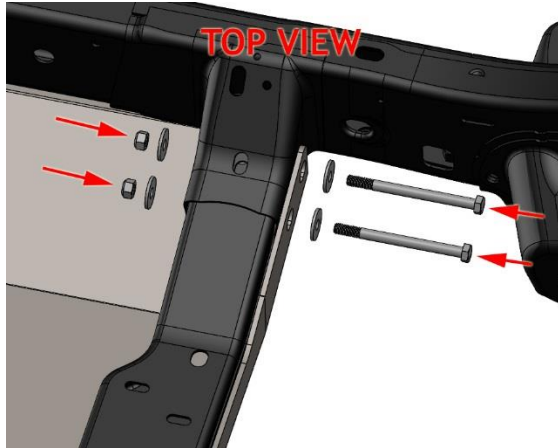

Step 6:

Install one of the bolts removed in step 1 in the back corner of the transfer case skid plate, and 1 bolt in the opposite side in the frame rail.

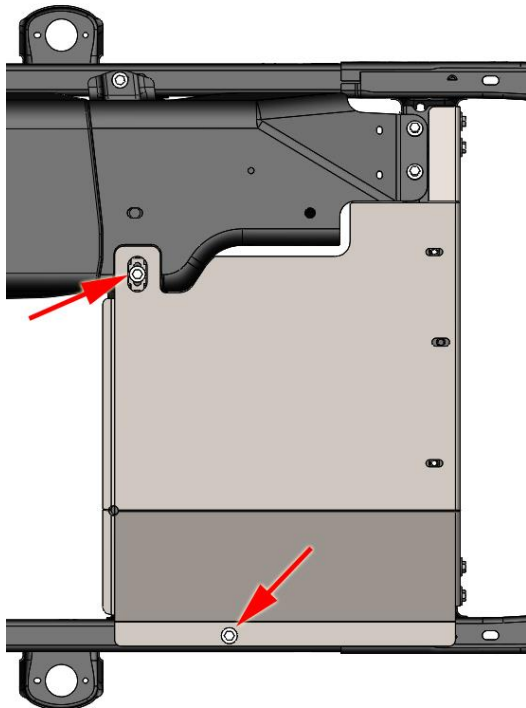

Step 7:

Remove the 2 front bolts and 1 side bolt from the factory fuel tank skid in the locations shown below. Retain these bolts, they will be re-used.

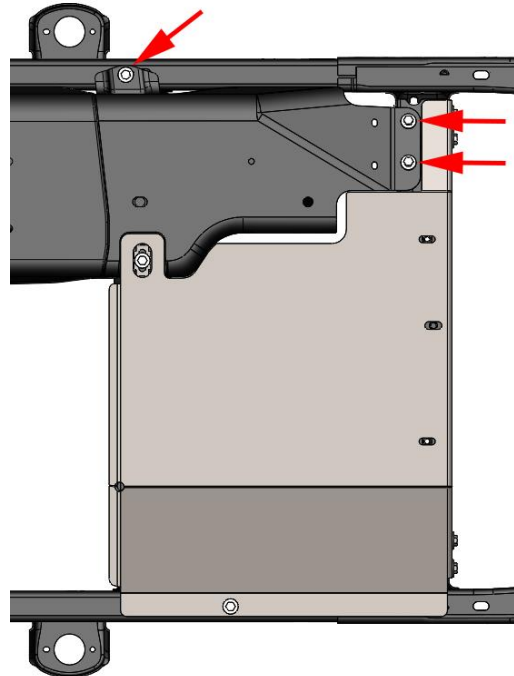

Step 8:

Lift the new fuel tank skid into place over the factory skid plate. Reinstall the three bolts that were removed in the last step and tighten. Place the provided bolt head protectors on the two front bolts during installation.

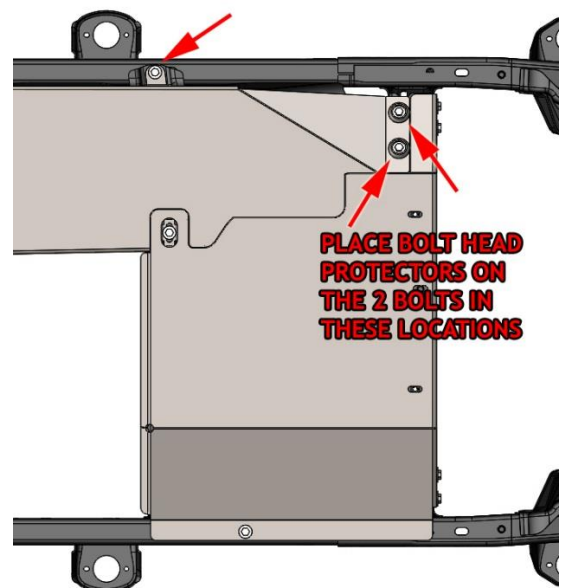

Step 9:

Remove the factory bolt in the back inside corner of the factory fuel tank skid. Using one of the 1/2"x1" bolts and 1/2" locknut, bolt the bracket to the outside of the new fuel tank skid. Install the bolt removed earlier in this step through the new bracket. The "crow foot" wrench provided in the kit can be used to help hold the 1/2" locknut to tighten the 1/2" bolt. Tighten all hardware attached to this bracket.

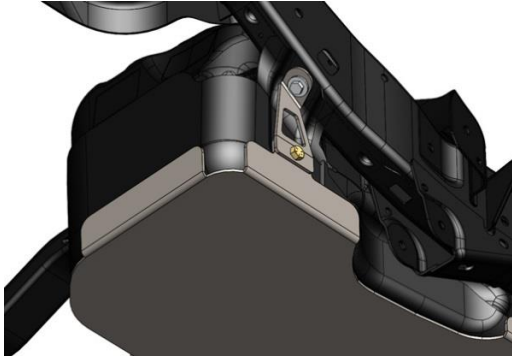

Step 10:

Install the two inside brackets on the fuel tank skid. The brackets will sit on the inside of the new fuel tank skid. The longer bracket will go to the rear location on the skid. Use the same method and hardware type as used in step 9.

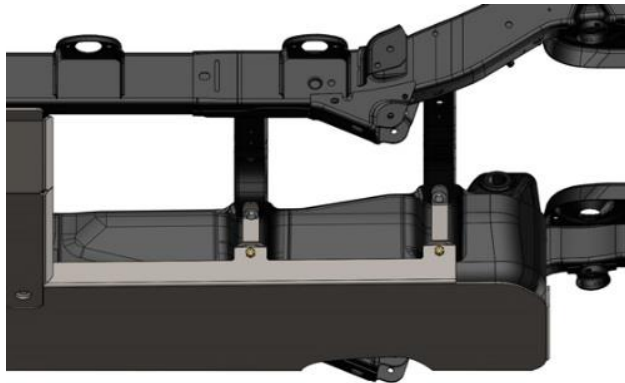

Step 11:

Install the two front engine skid plate support brackets with the provided 1/2"x1-1/2" bolts and 1/2" locknuts, a washer has been provided to install under the head of the bolt and the locknut. The brackets will attach to the engine mounts that are welded to the frame in existing holes. The bent bracket will install on the driver's side and the straight bracket will install on the passenger side. Only install the hardware hand tight at this point in the installation.

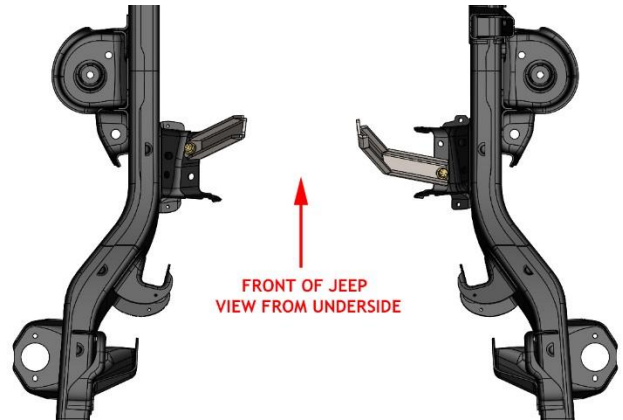

Step 12:

Lift the engine skid up to the bottom of the transfer case skid. Install the three bolts removed in step 1 in the crossmember with the provided bolt head protectors. Place the 2 1/2"x1-1/2" bolts 1/2" washers and locknuts through the engine skid and into the engine skid brackets.

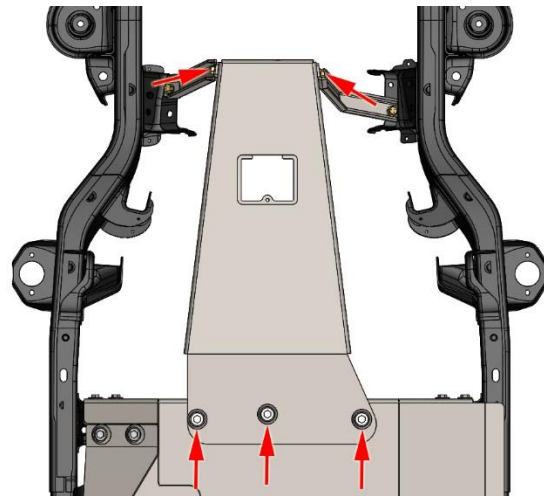

Step 13:

Install the oil change access panel using the provided 5/16"x1" countersunk screw.

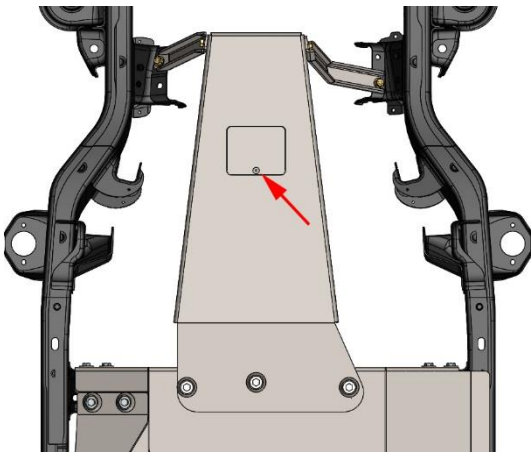

Step 14:

Tighten all hardware according to the torque values below.

1/2" Hardware 60 Ft-Lbs

12mm Hardware 60 Ft-Lbs

5/16" Hardware 10 Ft-Lbs

Step 15:

Fully cycle the front and rear suspension and verify clearance to all other components on the vehicle. On some models the webbing on the axle housing may need to be slightly trimmed.

Congratulations you have completed the installation of your JKU skid plates!

Professional Services Disclaimer:

The content of all pages of this website (collectively, the "Website"), such as text, graphics, images, information and other material (collectively, "Content") is for informational purposes only. Any information furnished on this Website is not intended nor implied to be automotive advice and is not intended to replace personal consultation with a qualified automotive service technician, mechanic, or similar automotive professional.

Barnes 4WD has not examined the Content for accuracy, timeliness, completeness, appropriateness, or helpfulness. Barnes 4WD does not endorse any specific tests, products, procedures, opinions, or other information that may be mentioned on this Website. Your reliance upon information and Content obtained by you at or through this Website is solely at your own risk. IN NO EVENT SHALL BARNES 4WD BE LIABLE OR OTHERWISE RESPONSIBLE FOR ANY DAMAGE OR INJURY (INCLUDING DEATH) TO YOU, OTHER PERSONS, OR PROPERTY ARISING FROM ANY USE OF ANY PRODUCT, INFORMATION, IDEA, OR INSTRUCTION CONTAINED IN THE CONTENT.

BARNES 4WD DOES NOT MAKE ANY REPRESENTATION OR WARRANTY, EXPRESS OR IMPLIED, AT LAW OR IN EQUITY, WITH RESPECT TO ANY PRODUCT FEATURED ON THE WEBSITE, INCLUDING WITHOUT LIMITATION WITH RESPECT TO MERCHANTABILITY, FITNESS FOR ANY PARTICULAR PURPOSE, VALUE, VALIDITY, OR ENFORCEABILITY, AND ANY AND ALL SUCH OTHER REPRESENTATIONS OR WARRANTIES ARE HEREBY EXPRESSLY DISCLAIMED.