

Thank You for Purchasing Barnes 4WD

JEEP TJ REAR FRAME LOWER CONTROL ARM BRACKET

Installation Notes:

- This bracket is designed to replace the OEM TJ Frame Rear Lower Control Arm Bracket
- The mounting width of the bracket is 2 5/8" With a 14mm bolt hole.
- You'll need to measure off the OEM upper rear control arm bracket.
- Installation of this product requires a trained welder.
- Removal of existing bracketry is required for installation.
- Refer to your vehicle's factory service manual for removal of any factory components.

Tools Required:

- Welding machine with the capability of welding at least 3/16" steel.
- Proper cutting tool (Grinder with cut off wheel, plasma cutter, cutting torch, etc.)
- Ratchet and Metric Socket Set.
- Tape measure

Step 1:

Park Jeep on level surface. Unbolt rear frame lower control arms.

Step 2:

Using a proper cutting tool remove the OEM rear lower control arm bracket.

Step 3:

Locate the Barnes 4WD Jeep Rear Frame Lower Control Arm Bracket on the frame. The lower control arm bracket should be 3 3/4" from the OEM upper control arm bracket as shown in the picture below. This will locate the bracket in the same location as the OEM bracket that has been removed.

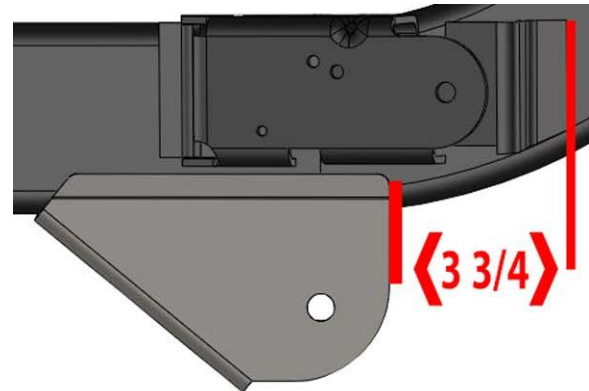

Step 4:

Once the Barnes 4WD Jeep TJ Rear Frame Lower Control Arm Bracket is in the same location as the OEM bracket tack weld it to the frame.

Step 5:

Ensure fitment of Jeep TJ Rear Frame Lower Control Arm Bracket by bolting the control arm into the bracket. With fitment ensured unbolt the control arm.

Step 6:

With the placement of the Barnes 4WD bracket satisfied. Fully weld the bracket to the frame.

Step 7:

Repeat Steps 1-6 for the other side.

Congratulations! You have Completed Installation of your Barnes 4WD Jeep TJ Rear Frame Lower Control Arm Brackets.

Professional Services Disclaimer:

The content of all pages of this website (collectively, the “Website”), such as text, graphics, images, information and other material (collectively, “Content”) is for informational purposes only. Any information furnished on this Website is not intended nor implied to be automotive advice and is not intended to replace personal consultation with a qualified automotive service technician, mechanic, or similar automotive professional.

Barnes 4WD has not examined the Content for accuracy, timeliness, completeness, appropriateness, or helpfulness. Barnes 4WD does not endorse any specific tests, products, procedures, opinions, or other information that may be mentioned on this Website. Your reliance upon information and Content obtained by you at or through this Website is solely at your own risk. IN NO EVENT SHALL BARNES 4WD BE LIABLE OR OTHERWISE RESPONSIBLE FOR ANY DAMAGE OR INJURY (INCLUDING DEATH) TO YOU, OTHER PERSONS, OR PROPERTY ARISING FROM ANY USE OF ANY PRODUCT, INFORMATION, IDEA, OR INSTRUCTION CONTAINED IN THE CONTENT.

BARNES 4WD DOES NOT MAKE ANY REPRESENTATION OR WARRANTY, EXPRESS OR IMPLIED, AT LAW OR IN EQUITY, WITH RESPECT TO ANY PRODUCT FEATURED ON THE WEBSITE, INCLUDING WITHOUT LIMITATION WITH RESPECT TO MERCHANTABILITY, FITNESS FOR ANY PARTICULAR PURPOSE, VALUE, VALIDITY, OR ENFORCEABILITY, AND ANY AND ALL SUCH OTHER REPRESENTATIONS OR WARRANTIES ARE HEREBY EXPRESSLY DISCLAIMED.

