

## JEEP JK Front Axle Lower Control Arm Brackets

Thank you for purchasing Barnes 4WD  
JEEP JK Front Axle Lower Control Arm  
Brackets

### Installation Notes:

- This bracket is designed to replace the OEM JK Front Axle Lower Control Arm Brackets
- Installation of this product requires a trained welder
- Cutting off existing bracketry is required for installation
- Refer to your vehicle's factory service manual for removal of any factory components

### Tools Required:

- Welding machine with the capability of welding at least  $\frac{1}{4}$ " steel.
- Proper cutting tool (Grinder with cut off wheel, plasma cutter, cutting torch, etc.)
- Tape Measure

### Step 1:

Park the Jeep on a level surface and remove the front lower control arms.

### Step 2:

Measure the location of the OEM bracket on the axle. Make a note of these measurements the Barnes 4WD Jeep JK Front Axle Lower Control Arm Brackets will need to be located in the same location as the OEM Brackets.

### Step 3:

Using the proper cutting tool remove the OEM front lower control arm bracket. By cutting in the locations shown in the pictures below.

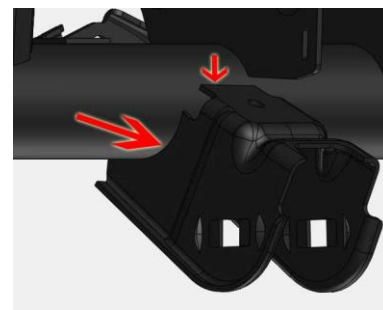
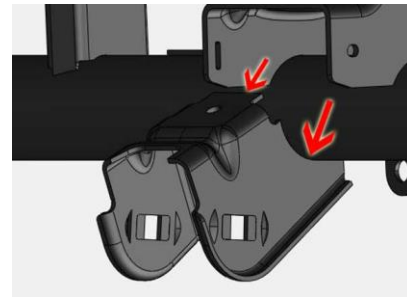

### Step 4:

Place the Barnes 4WD front lower control arm bracket on the axle. The lower control arm bracket should be  $3 \frac{9}{16}$ " from the edge of the OEM coil bucket. The bottom of the OEM coil bucket and the top of the lower control arm bracket should be parallel.

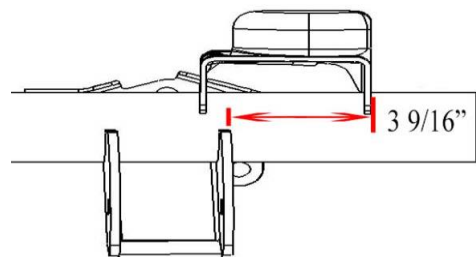

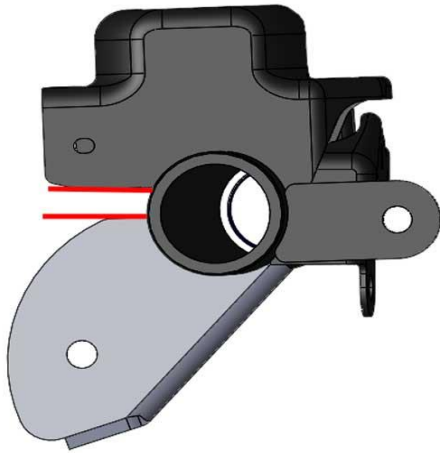

#### Step 5:

Once the lower control arm bracket is in the desired location tack weld into place. In the locations shown in the picture below.

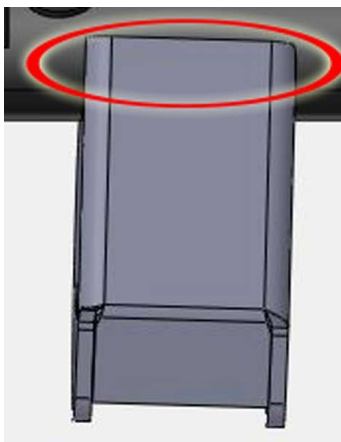
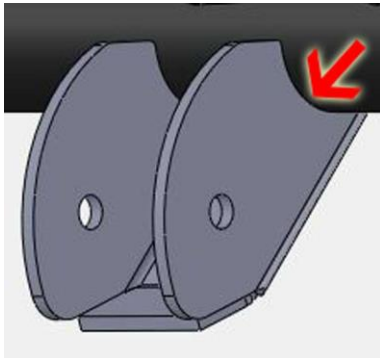

#### Step 6:

Reinstall the lower control arm to make sure the lower control arm bracket is in the right location.

#### Step: 7

Once the lower control arm bracket is in its desired location fully weld it into place. Repeat steps 3 through 7 on the opposite side of the Jeep.

Congratulations! You have Completed Installation of your Barnes 4WD JEEP JK Front Axle Lower Control Arm Brackets.

#### Professional Services Disclaimer:

The content of all pages of this website (collectively, the "Website"), such as text, graphics, images, information and other material (collectively, "Content") is for informational purposes only. Any information furnished on this Website is not intended nor implied to be automotive advice and is not intended to replace personal consultation with a qualified automotive service technician, mechanic, or similar automotive professional. Barnes 4WD has not examined the Content for accuracy, timeliness, completeness, appropriateness, or helpfulness. Barnes 4WD does not endorse any specific tests, products, procedures, opinions, or other information that may be mentioned on this Website. Your reliance upon information and Content obtained by you at or through this Website is solely at your own risk. IN NO EVENT SHALL BARNES 4WD BE LIABLE OR OTHERWISE RESPONSIBLE FOR ANY DAMAGE OR INJURY (INCLUDING DEATH) TO YOU, OTHER PERSONS, OR PROPERTY ARISING FROM ANY USE OF ANY PRODUCT, INFORMATION, IDEA, OR INSTRUCTION CONTAINED IN THE CONTENT. BARNES 4WD DOES NOT MAKE ANY REPRESENTATION OR WARRANTY, EXPRESS OR IMPLIED, AT LAW OR IN EQUITY, WITH RESPECT TO ANY PRODUCT FEATURED ON THE WEBSITE, INCLUDING WITHOUT LIMITATION WITH RESPECT TO MERCHANTABILITY, FITNESS FOR ANY PARTICULAR PURPOSE, VALUE, VALIDITY, OR ENFORCEABILITY, AND ANY AND ALL SUCH OTHER REPRESENTATIONS OR WARRANTIES ARE HEREBY EXPRESSLY DISCLAIMED.