



Bronco Rear Axle Upper Control Arm Brackets Installation Instructions

Thank you for purchasing our Bronco Rear Axle Upper Control Arm Brackets!

Installation Notes:

- The brackets are designed to fit a 2021-Current Bronco
- These brackets will not fit a Bronco Sport
- Removal of the factory brackets is required for installation.
- Refer to your factory service manual on removal of any factory components.

Tools required:

- Proper Cutting Tool (Grinder, Plasma Cutter, Torch)
- Welder with at least .25" Capabilities
- Tape Measure
- Angle Finder
- 24MM Socket
- 10MM Socket
- 13MM Wrench
- Ratchet

Contents of box

Bill Of Materials for B4WK12706			
QTY	Part Number	Etch Number	Description
1	B4W188975	975B	Bronco Rear Axle UCA Bracket Passenger
1	B4W188976	976B	Bronco Rear Axle UCA Bracket Driver
1	B4W125124	124B	Bronco Rear Axle UCA Bracket Brake Line Tab Passenger
1	B4W125125	125B	Bronco Rear Axle UCA Bracket Brake Line Tab Driver
1	.80CNFH0Z/934	NA	M8X1.25 hex nut class 8 zinc

Step 1:

Park the Bronco on a level surface, support the frame and remove the rear upper control arms at the axle and any brackets connected to the lower control arm brackets.

Step 2:

Locate the rear upper control arm brackets and remove them with a proper cutting tool.

Step 3:

Weld each tab its correct bracket as shown below.



Step 4:

Place the Barnes4wd upper control arm brackets onto the axle the passenger mount should be $5 \frac{1}{8}$ " from the flange of the center section and the driver mount should be $\frac{15}{16}$ " from the opposite side of the center section as shown below. The back face of the bracket should be 48° off the pinion.

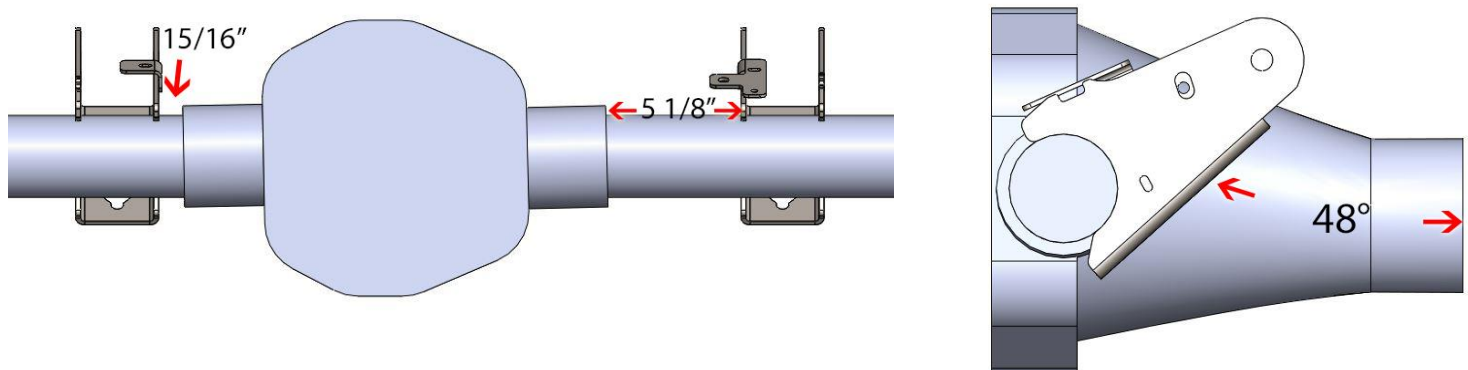

Step 5:

Fully weld the brackets to the axle.

Step 6:

Reinstall the upper control arms into the brackets. Install any brackets that were connected to the factory upper control arm brackets using the supplied hardware.

Congratulations! You Have finished the installation of the Barnes 4wd Bronco Rear Upper Control Arm Brackets.

Professional Services Disclaimer:

The content of all pages of this website (collectively, the "Website"), such as text, graphics, images, information and other material (collectively, "Content") is for informational purposes only. Any information furnished on this Website is not intended nor implied to be automotive advice and is not intended to replace personal consultation with a qualified automotive service technician, mechanic, or similar automotive professional.

Barnes 4WD has not examined the Content for accuracy, timeliness, completeness, appropriateness, or helpfulness. Barnes 4WD does not endorse any specific tests, products, procedures, opinions, or other information that may be mentioned on this Website. Your reliance upon information and Content obtained by you at or through this Website is solely at your own risk. IN NO EVENT SHALL BARNES 4WD BE LIABLE OR OTHERWISE RESPONSIBLE FOR ANY DAMAGE OR INJURY (INCLUDING DEATH) TO YOU, OTHER PERSONS, OR PROPERTY ARISING FROM ANY USE OF ANY PRODUCT, INFORMATION, IDEA, OR INSTRUCTION CONTAINED IN THE CONTENT.

BARNES 4WD DOES NOT MAKE ANY REPRESENTATION OR WARRANTY, EXPRESS OR IMPLIED, AT LAW OR IN EQUITY, WITH RESPECT TO ANY PRODUCT FEATURED ON THE WEBSITE, INCLUDING WITHOUT LIMITATION WITH RESPECT TO MERCHANTABILITY, FITNESS FOR ANY PARTICULAR PURPOSE, VALUE, VALIDITY, OR ENFORCEABILITY, AND ANY AND ALL SUCH OTHER REPRESENTATIONS OR WARRANTIES ARE HEREBY EXPRESSLY DISCLAIMED.