

2007-2018 Jeep Wrangler JK and Wrangler Unlimited JKU Pritchett Canyon Frame Chop Rear Bumper Installation Instructions

Thank you for purchasing our Jeep JK Frame Chop Rear Bumper

Installation Notes:

- Installation of this bumper requires removal of a rear section of the frame and crossmember
- We recommend test fitting the bumper before painting or powder coating
- Drilling is required
- Refer to the factory service manual for your vehicle for removal of any OEM parts
- We recommend applying a rust preventive coating (paint, etc) on all bare metal surfaces after cutting or drilling
- The 2" accessory mount is not intended for towing. It is only intended for light weight attachments under 200 lbs (bicycle rack, cargo carrier, etc.)

Tools Required:

- Various hand tools for the removal of the existing bumper
- Appropriate cutting tool (grinder with a cut-off wheel, reciprocating saw, plasma cutter, torch, etc)
- 3/4" Combination wrench
- 3/4" Socket
- Drill
- 1/2" Drill bit

Step 1:

Remove the existing rear bumper and tow hook from the Jeep. Retain all hardware.

Step 2:

The frame needs to be trimmed 4 inches from the end of the frame rail. The cut will fall directly between the rear body mount and the crossmember. Using an appropriate cutting tool, remove the ends of the frame rails and the crossmember.

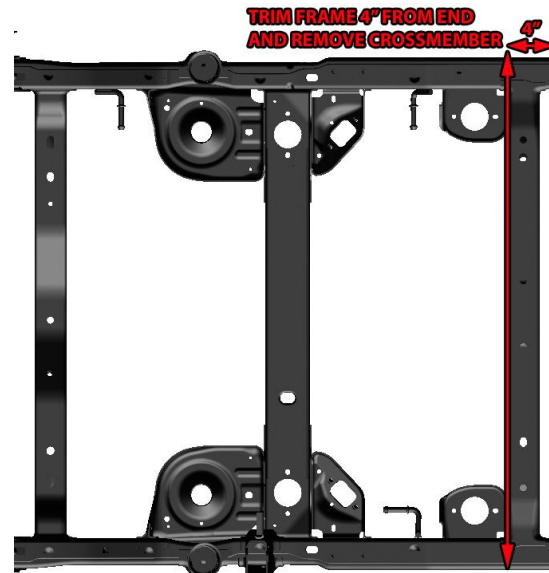

Step 3:

Using the hardware removed from the side of the frame in step one, attach the provided mounting brackets to each side of the frame in the factory holes.

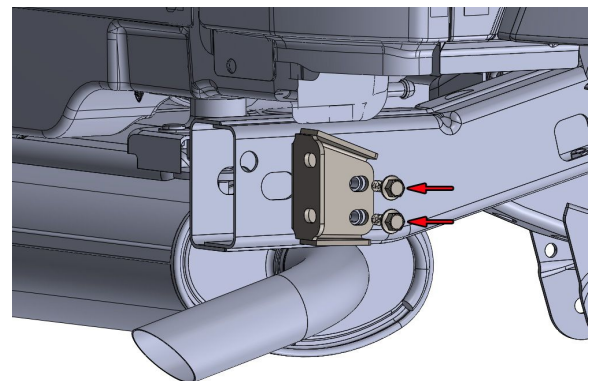

**Step 4:**

Insert the provided flag nut inside the drivers side frame rail. Align the nuts with the two holes in the bottom of the frame. The bent tab on the flag nut should protrude out of the slot on the inside of the frame rail.

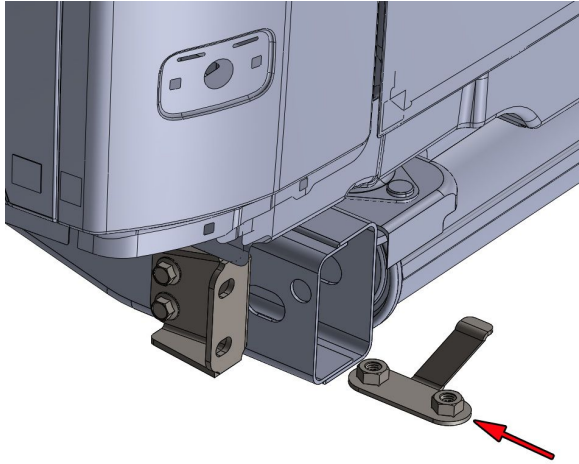

**Step 6:**

Install the two provided 1/2" bolts with washers up through the holes in the bottom of the driver frame rail into the flag nut installed in step 4. Tighten the two bolts to close the gap between the frame and bumper.

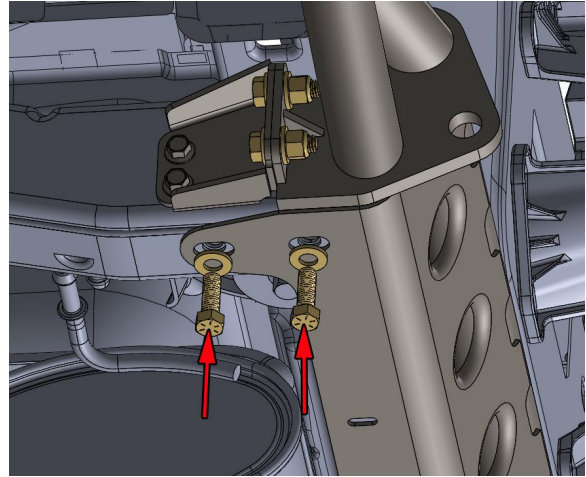

**Step 5:**

Using the provided 1/2" bolts, nuts, and washers attach the bumper to the brackets installed in step 3 on both sides. Only tighten the hardware enough to close the gap between the bumper and the brackets.

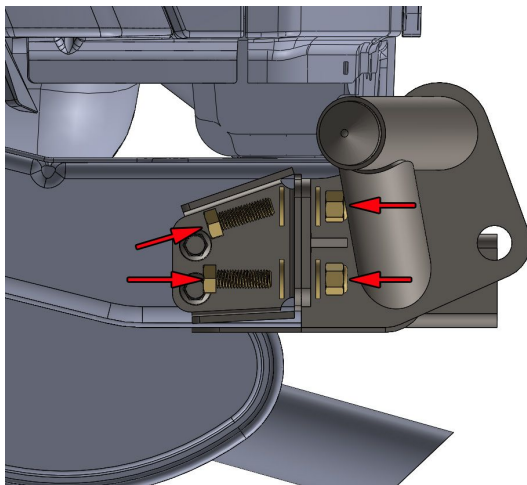

**Step 7:**

Take care to make sure the bottom of the bumper is touching the bottom of the frame. Tighten the hardware installed in step 5.

**Step 8:**

Mark the center position of the 2 slots in the bottom of the bumper on the passenger frame rail. Use a center punch to mark the holes in preparation for drilling.

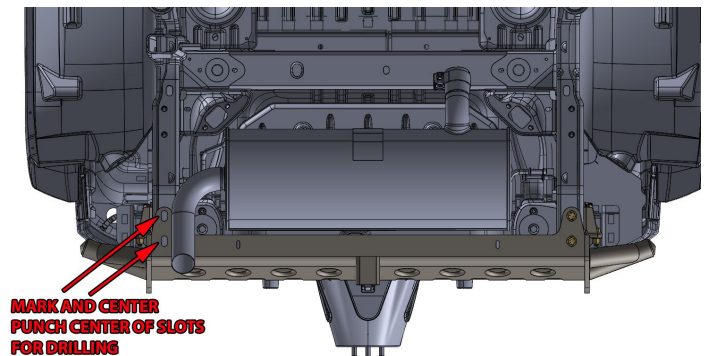

**Step 9:**

Remove the bumper and drill two ½” holes in the locations marked in step 8.

**Step 10:**

Place the supplied flag nut inside the passenger side frame rail.

**Step 11:**

Place the bumper back on to the Jeep. Install all hardware that was removed in step 9 and the 2 additional ½” bolts and washers in the passenger frame rail into the flag nut installed in the last step. Tighten all hardware to 60 ft-lbs.

**Congratulations you have completed the installation of your bumper!.**

**Professional Services Disclaimer:**

The content of all pages of this website (collectively, the "Website"), such as text, graphics, images, information and other material (collectively, "Content") is for informational purposes only. Any information furnished on this Website is not intended nor implied to be automotive advice and is not intended to replace personal consultation with a qualified automotive service technician, mechanic, or similar automotive professional.

Barnes 4WD has not examined the Content for accuracy, timeliness, completeness, appropriateness, or helpfulness. Barnes 4WD does not endorse any specific tests, products, procedures, opinions, or other information that may be mentioned on this Website. Your reliance upon information and Content obtained by you at or through this Website is solely at your own risk. IN NO EVENT SHALL BARNES 4WD BE LIABLE OR OTHERWISE RESPONSIBLE FOR ANY DAMAGE OR INJURY (INCLUDING DEATH) TO YOU, OTHER PERSONS, OR PROPERTY ARISING FROM ANY USE OF ANY PRODUCT, INFORMATION, IDEA, OR INSTRUCTION CONTAINED IN THE CONTENT. BARNES 4WD DOES NOT MAKE ANY REPRESENTATION OR WARRANTY, EXPRESS OR IMPLIED, AT LAW OR IN EQUITY, WITH RESPECT TO ANY PRODUCT FEATURED ON THE WEBSITE, INCLUDING WITHOUT LIMITATION WITH RESPECT TO MERCHANTABILITY, FITNESS FOR ANY PARTICULAR PURPOSE, VALUE, VALIDITY, OR ENFORCEABILITY, AND ANY AND ALL SUCH OTHER REPRESENTATIONS OR WARRANTIES ARE HEREBY EXPRESSLY DISCLAIMED.