



## 05 and up Superduty Dana 60 Leaf Spring Conversion Installation Instructions

Thank you for purchasing our 05 and up Superduty Dana 60 Leaf Spring Conversion!

### Installation Notes:

- Extensive Trimming of the casting will need to be done to install this kit.
- This kit can only be used with leaf springs with a minimum center to center width of 37 inches.
- This kit will only work with a 2.5 inch wide leaf spring.
- This kit will only fit 2005-Present Ford F250 and F350 axles.
- Half of the driver's side leaf spring perch will need to be welded to casting

### Tools required:

- Welding machine with the capability to weld at least 1/4" thick steel
- Grinder
- Cutting torch, plasma cutter or other appropriate cutting tool

## Contents of box

Bill Of Materials for B4WK12638			
QTY	Part Number	Etch Number	Description
1	B4W250877	877 B	Super Duty Dana 60 Leaf Spring Perch 2.5" Wide Spring
1	B4W250876	876 B	Leaf Spring Perch 2.5" Wide Spring 3.75 Axle Tube
2	B4W375213	213 B	Leaf Spring Top Plate 2.5" Wide Spring 3.75 Axle Tube
3	B4WUR3750	NA	U-Bolt Round 3 3/4"
1	B4WUR5125	NA	U-Bolt Round 5 1/8"

## Step 1:

The casting on the Dana 60 axle will need to be trimmed. The cast section of the radius arm bracket on the driver's side will need to be removed, as well as a short section of the casting where the tube enters the center section. See images below for the areas to trim. The end of the casting where the driver tube enters the center section will need to be trimmed back 2". After trimming the casting grind all edges smooth.

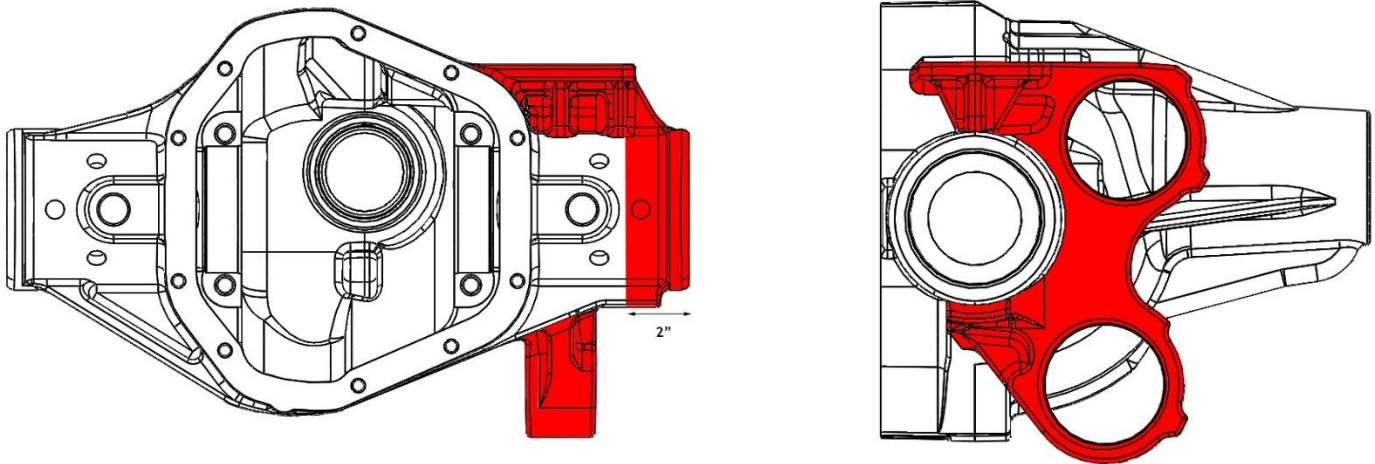

## Step 2:

Once you have trimmed the casting and determined the location of your driver's side leaf spring perch the bottom webbing will need to be notched to fit the ubolt.

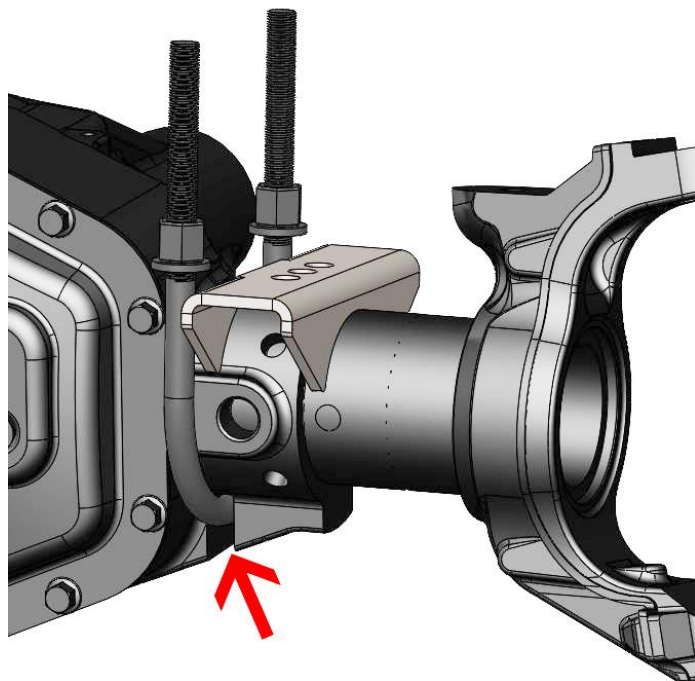

### **Step 3:**

Fully weld all leaf spring perches and install leaf springs, U bolts, and u bolt plates. Torque u bolts to 150 FTLB.

## **Congratulations! You have finished the installation of the Barnes4wd 05 and up Superduty Dana 60 Leaf Spring Conversion.**

#### Professional Services Disclaimer:

The content of all pages of this website (collectively, the "Website"), such as text, graphics, images, information and other material (collectively, "Content") is for informational purposes only. Any information furnished on this Website is not intended nor implied to be automotive advice and is not intended to replace personal consultation with a qualified automotive service technician, mechanic, or similar automotive professional.

Barnes 4WD has not examined the Content for accuracy, timeliness, completeness, appropriateness, or helpfulness. Barnes 4WD does not endorse any specific tests, products, procedures, opinions, or other information that may be mentioned on this Website. Your reliance upon information and Content obtained by you at or through this Website is solely at your own risk. IN NO EVENT SHALL BARNES 4WD BE LIABLE OR OTHERWISE RESPONSIBLE FOR ANY DAMAGE OR INJURY (INCLUDING DEATH) TO YOU, OTHER PERSONS, OR PROPERTY ARISING FROM ANY USE OF ANY PRODUCT, INFORMATION, IDEA, OR INSTRUCTION CONTAINED IN THE CONTENT.

BARNES 4WD DOES NOT MAKE ANY REPRESENTATION OR WARRANTY, EXPRESS OR IMPLIED, AT LAW OR IN EQUITY, WITH RESPECT TO ANY PRODUCT FEATURED ON THE WEBSITE, INCLUDING WITHOUT LIMITATION WITH RESPECT TO MERCHANTABILITY, FITNESS FOR ANY PARTICULAR PURPOSE, VALUE, VALIDITY, OR ENFORCEABILITY, AND ANY AND ALL SUCH OTHER REPRESENTATIONS OR WARRANTIES ARE HEREBY EXPRESSLY DISCLAIMED.