

TIOMOS PCC

Pie-cut corner hinge

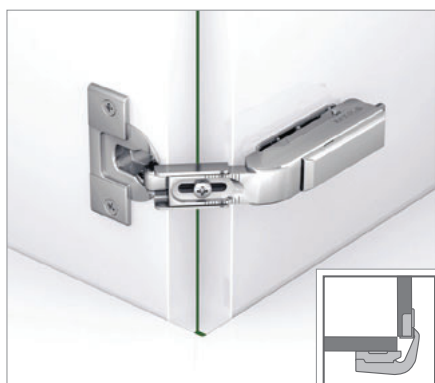

- For connecting two corner cabinet doors
- For door thicknesses up to 24 mm (factory setting for 19 mm door thickness with cup distance 3.5 mm)
- 35 mm full cup drill hole
- Shallow cup depth of 11.8 mm
- 3-dimensional adjustment with corresponding mounting plate
- Without integrated damper

Available in one version:

- Without integrated damper

ORDER INFORMATION FOR DRILLING PATTERN 45/9.5, NICKEL

Door overlay		Damper		Without spring	Art. No.		
		With	Without		Click-on for screw fitting	Click-on for press fitting	
1		-	■	-	F045138517	F045138518	

¹ Cup material: steel, nickel-plated/Arm material: zamak, nickel-plated

PAGE REFERENCES

Tiomos mounting plates	86
Accessories	96
Technical information	100

Assembly technology	637
Assembly aids	654

PLANNING DIMENSIONS

All dimensions in millimetres

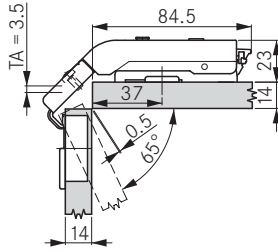

Door thickness (TS) 14 mm
Cup distance (TA) 3.5 mm
Mounting plate height 0

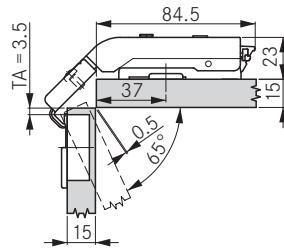

Door thickness (TS) 15 mm
Cup distance (TA) 3.5 mm
Mounting plate height 0

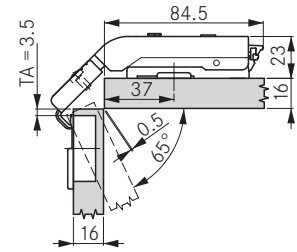

Door thickness (TS) 16 mm
Cup distance (TA) 3.5 mm
Mounting plate height 0

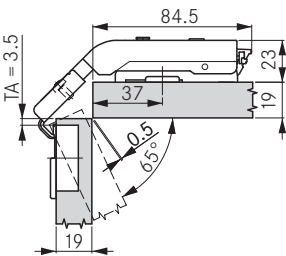

Door thickness (TS) 19 mm (factory setting)
Cup distance (TA) 3.5 mm
Mounting plate height 0

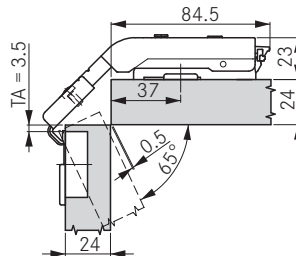

Door thickness (TS) 24 mm
Cup distance (TA) 3.5 mm
Mounting plate height 0

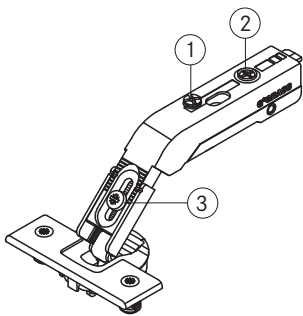

Adjustment in the hinge arm:

1. Stepless side adjustment ± 2 mm
2. Stepless depth adjustment via worm screw $+3/-2$ mm
3. Door thickness 14-24 mm (factory setting 19 mm)

Height adjustment via mounting plate

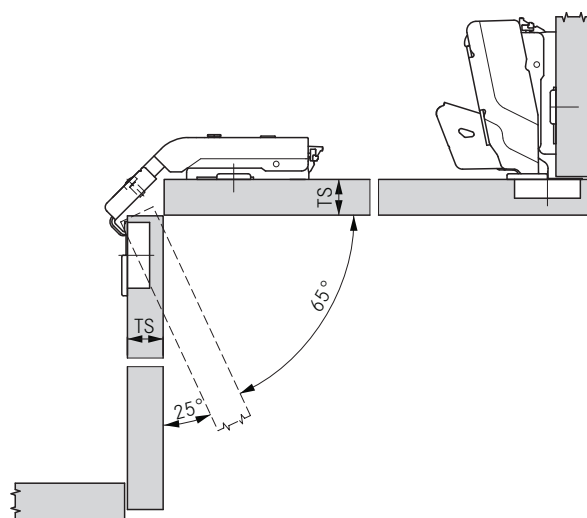

DRILLING PATTERNS 45/9.5

For screw fitting

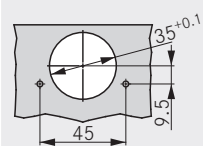

For press fitting

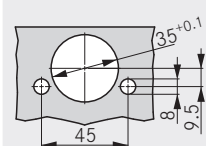

CUP DIMENSIONS

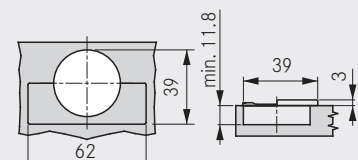

1

2

3

4

5

6

7

8