



Salice Face Frame or Frameless Application Inset Hinges

Product #159653, 159654

Hinge Mounting Instructions

A. Decide on the number of hinges you want to use and mark their centerline locations on the back of the door (see Figure 1).

Face Frame Application: You will need to add a block behind the Face Frame, flush with the opening.

B. Transfer the centerline to the inside of the cabinet.

C. Using a 35mm (1³/₈") forstner bit bore the mounting hole for the hinge cup in the back of the door to a depth of 12mm, slightly less than 1/2" so the bore edge is 4mm from door edge (fig. 2). Center of cup is 21.5mm from door edge. Drilling distance in from door edge may be adjusted slightly to change the reveal. To insure the proper operation of the installation we suggest that you make a sample and test the fit and reveal as needed before actually boring the finished stock.

D. Locate the screw hole centerlines for the mounting clip 37mm from the front edge of the cabinet. Align the center of the mounting plate with the hinge centerline previously marked on the inside of the cabinet and install screws (see Figure 2).

E. With the hinges in the open position simply "clip" the arm to the mounting plate and follow the diagram for "three-way" adjustment- See page 2.

Number of Hinges per Door

There is no general rule. Obviously this depends on the size and weight of the door. We can give you a rough guide for the more standard applications. In special cases (a door with a mirror) we suggest you conduct a trial for yourself.

- S** = Thickness of the cabinet side
- T** = Door thickness
- K** = Drilling distance
- A** = Reveal
- L** = Gap between internal face of door and internal cabinet elements (e.g. shelves, drawers, etc.)
- H** = Height of the mounting plate
- G** = Hinge constant

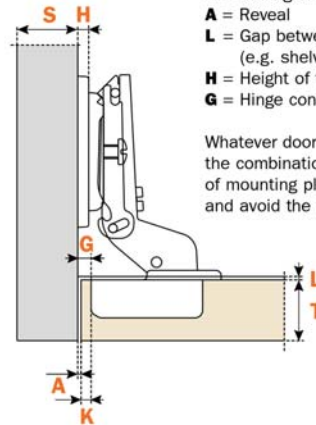

Whatever door overlay is required, you can select from our range the combination of both the type of hinge arm and the thickness of mounting plate necessary to solve your construction problem and avoid the need to stock too many different components.

Fig. 1

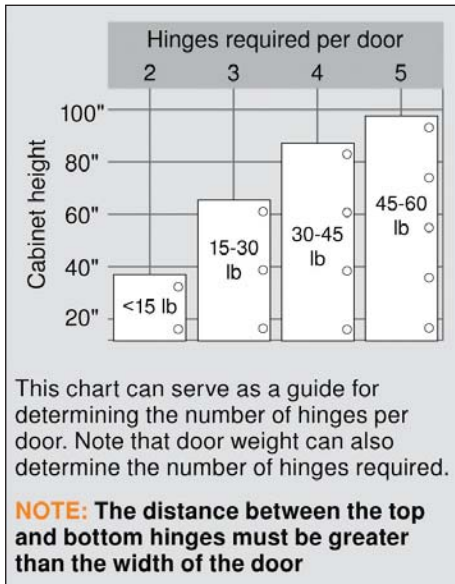
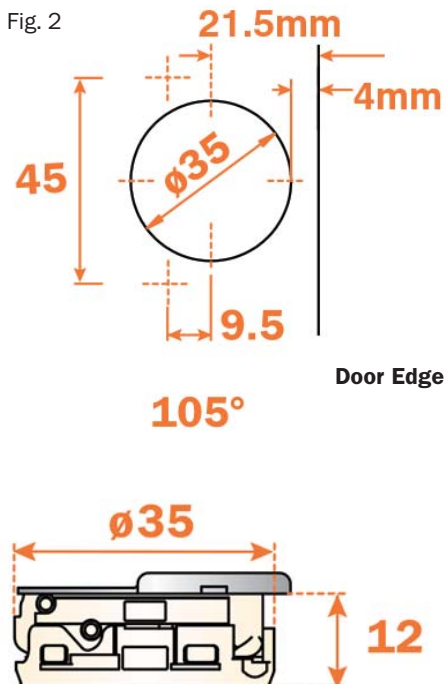

Fig. 2



| Millimeter to inch equivalents - Correspondencia entre pulgadas y milímetros | | | | | | | | | | | | | | | | |
|--|-------|--------|-------|--------|--------|--------|-------|--------|--------|--------|--------|--------|--------|--------|--------|------|
| mm | 1 | 1.5 | 2 | 3 | 4 | 5 | 5.5 | 6 | 7 | 8 | 9 | 9.5 | 10 | 11 | 12 | 13 |
| inch | 1/32" | 1/16" | 3/32" | 1/8" | 5/32" | 3/16" | 7/32" | 1/4" | 9/32" | 5/16" | 11/32" | 3/8" | 13/32" | 7/16" | 15/32" | 1/2" |
| mm | 14 | 15 | 16 | 17 | 17.5 | 18 | 19 | 20 | 20.5 | 21 | 22 | 23 | 24 | 24.5 | 25.4 | |
| inch | 9/16" | 19/32" | 5/8" | 21/32" | 11/16" | 23/32" | 3/4" | 25/32" | 13/16" | 27/32" | 7/8" | 29/32" | 15/16" | 31/32" | 1" | |



Salice Face Frame Application Overlay Hinges

Product #159653, 159654

Traditional Depth Adjustment

Frontal adjustment is made without loosening any screws. The door can be moved frontally from -0.5 to $+2.8$ mm. by rotating the cam adjuster incorporated in this range of mounting plates.

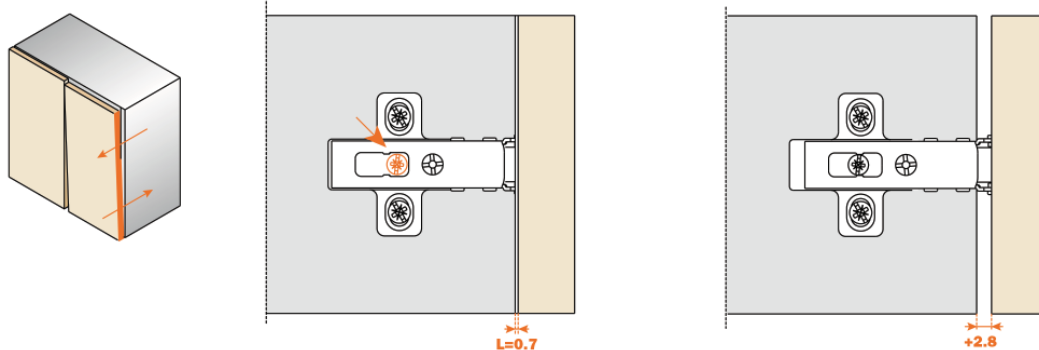

Sideways Adjustment

A specially developed technical solution allows the sideways adjustment of the door while maintaining the door gap behind the door ("L" value of 0.7mm). The adjustment screw operates in conjunction with the inner leaf of the hinge arm. the door moves in only one direction - parallel to the carcass and without a gap developing between the door and the carcass. No further adjustments are necessary.

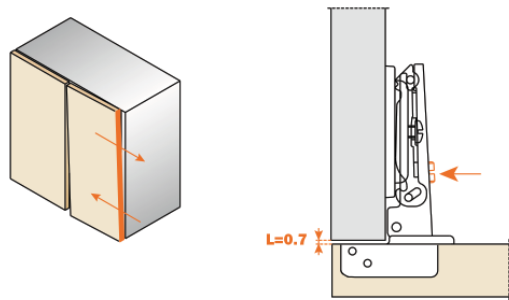

Height Adjustment

Height adjustment is made without loosening any screws. The door can be moved vertically ± 2 mm by rotating the cam adjuster incorporated in this range of mounting plates

