



Operating Instructions and Parts Manual JWS-20CS Spindle Shaper



Shown with optional extension table #724021 (ordered separately)

JET
427 New Sanford Road
LaVergne, Tennessee 37086
Ph.: 800-274-6848
www.jettools.com

Part No. M-724020
Edition 1 11/2022
Copyright © 2022 JET

Warranty and Service

JET warrants every product it sells against manufacturers' defects. If one of our tools needs service or repair, please contact Technical Service by calling 1-800-274-6846, 8AM to 5PM CST, Monday through Friday.

Warranty Period

The general warranty lasts for the time period specified in the literature included with your product or on the official JET branded website.

- JET products carry a limited warranty which varies in duration based upon the product. (See chart below)
- Accessories carry a limited warranty of one year from the date of receipt.
- Consumable items are defined as expendable parts or accessories expected to become inoperable within a reasonable amount of use and are covered by a 90 day limited warranty against manufacturer's defects.

Who is Covered

This warranty covers only the initial purchaser of the product from the date of delivery.

What is Covered

This warranty covers any defects in workmanship or materials subject to the limitations stated below. This warranty does not cover failures due directly or indirectly to misuse, abuse, negligence or accidents, normal wear-and-tear, improper repair, alterations or lack of maintenance. JET woodworking machinery is designed to be used with Wood. Use of these machines in the processing of metal, plastics, or other materials may void the warranty. The exceptions are acrylics and other natural items that are made specifically for wood turning.

Warranty Limitations

Woodworking products with a Five Year Warranty that are used for commercial or industrial purposes default to a Two Year Warranty. Please contact Technical Service at 1-800-274-6846 for further clarification.

How to Get Technical Support

Please contact Technical Service by calling 1-800-274-6846. **Please note that you will be asked to provide proof of initial purchase when calling.** If a product requires further inspection, the Technical Service representative will explain and assist with any additional action needed. JET has Authorized Service Centers located throughout the United States. For the name of an Authorized Service Center in your area call 1-800-274-6846 or use the Service Center Locator on the JET website.

More Information

JET is constantly adding new products. For complete, up-to-date product information, check with your local distributor or visit the JET website.

How State Law Applies

This warranty gives you specific legal rights, subject to applicable state law.

Limitations on This Warranty

JET LIMITS ALL IMPLIED WARRANTIES TO THE PERIOD OF THE LIMITED WARRANTY FOR EACH PRODUCT. EXCEPT AS STATED HEREIN, ANY IMPLIED WARRANTIES OF MERCHANTABILITY AND FITNESS FOR A PARTICULAR PURPOSE ARE EXCLUDED. SOME STATES DO NOT ALLOW LIMITATIONS ON HOW LONG AN IMPLIED WARRANTY LASTS, SO THE ABOVE LIMITATION MAY NOT APPLY TO YOU.

JET SHALL IN NO EVENT BE LIABLE FOR DEATH, INJURIES TO PERSONS OR PROPERTY, OR FOR INCIDENTAL, CONTINGENT, SPECIAL, OR CONSEQUENTIAL DAMAGES ARISING FROM THE USE OF OUR PRODUCTS. SOME STATES DO NOT ALLOW THE EXCLUSION OR LIMITATION OF INCIDENTAL OR CONSEQUENTIAL DAMAGES, SO THE ABOVE LIMITATION OR EXCLUSION MAY NOT APPLY TO YOU.

JET sells through distributors only. The specifications listed in JET printed materials and on official JET website are given as general information and are not binding. JET reserves the right to effect at any time, without prior notice, those alterations to parts, fittings, and accessory equipment which they may deem necessary for any reason whatsoever. JET® branded products are not sold in Canada by JPW Industries, Inc.

Product Listing with Warranty Period

90 Days – Parts; Consumable items; Light-Duty Air Tools
1 Year – Motors; Machine Accessories; Heavy-Duty Air Tools; Pro-Duty Air Tools
2 Year – Metalworking Machinery; Electric Hoists, Electric Hoist Accessories; Woodworking Machinery used for industrial or commercial purposes
5 Year – Woodworking Machinery
Limited Lifetime – JET Parallel clamps; VOLT Series Electric Hoists; Manual Hoists; Manual Hoist Accessories; Shop Tools; Warehouse & Dock products; Hand Tools

NOTE: JET is a division of JPW Industries, Inc. References in this document to JET also apply to JPW Industries, Inc., or any of its successors in interest to the JET brand.

Table of Contents

Warnings	4
Electrical Connections	6
Specifications	7
Unpacking and Cleanup	8
Setup and Adjustment	9
Spindle Removal and Installation	9
Collet Installation	9
Fence Placement and Adjustment	10
Table Ring Removal and Installation	10
Operation	11
Spindle Control	11
Using the Fence as a Guide	11
Shaping with Collars and Starting Pin	11
Collar Positioning	12
Starting Pin	13
Lubrication	13
Troubleshooting	14
Replacement Parts	15
JWS-20CS Base Assembly-Exploded View	16
JWS-20CS Base Assembly-Parts List	17
JWS-20CS Motor Assembly-Exploded View	18
JWS-20CS Motor Assembly-Parts List	19
JWS-20CS Spindle Assembly-Exploded View	20
JWS-20CS Spindle Assembly-Parts List	21
JWS-20CS Fence Assembly-Exploded View	22
JWS-20CS Fence Assembly-Parts List	23
JWS-20CS Safety Guard Assembly-Exploded View & Parts List	24
JWS-20CS Extension Table-Exploded View & Parts List	25
JWS-20CS Electrical Connections	26



Warnings

Wear eye protection.

Be sure keyed washer is directly under the spindle nut and the spindle nut is tight.

Feed the workpiece against the rotation of the cutter.

Do not use awkward hand positions.

Keep fingers away from the revolving cutter. Use fixtures when necessary.

Use the overhead guard when the adjustable fence is not in place.

- **KEEP GUARDS IN PLACE** and in working order.
- **REMOVE ADJUSTING KEYS AND WRENCHES.** Form a habit of checking to see that keys and adjusting wrenches are removed from the machine before turning it on.
- **KEEP THE WORK AREA CLEAN.** Cluttered areas and benches invite accidents.
- **DON'T USE IN A DANGEROUS ENVIRONMENT.** Don't use power tools in damp or wet locations, or expose them to rain. Keep work area well lighted.
- **KEEP CHILDREN AWAY.** All visitors should be kept a safe distance from the work area.
- **MAKE THE WORKSHOP KIDPROOF** with padlocks, master swatches, or by removing starter keys.
- **DON'T FORCE THE MACHINE.** It will do the job better and safer at the rate for which it was designed.
- **USE THE RIGHT MACHINE.** Don't force a machine or attachment to do a job for which it was not designed.
- **USE THE PROPER EXTENSION CORD.** Make sure your extension cord is in good condition. When using an extension cord, be sure to use one heavy enough to carry the current your machine will draw. An undersized cord will cause a drop in the line voltage resulting in power loss and overheating. The table below shows the correct size to use depending on cord length and nameplate ampere rating. If in doubt, use the next heavier gauge. The smaller the gauge, the heavier the cord.

Volts	Total Length of Cord in Feet			
	120V	25	50	100
240V	50	100	200	300
	AWG			
	16	16	14	12

- **WEAR PROPER APPAREL.** Do not wear loose clothing, gloves, neckties, rings, bracelets, or other jewelry which may get caught in moving parts. Nonslip footwear is recommended. Wear protective hair covering to contain long hair.
- **ALWAYS USE SAFETY GLASSES.** Also use face or dust masks if the cutting operation is dusty. Everyday eyeglasses only have impact resistant lenses; they are not safety glasses.
- **SECURE WORK.** Use clamps or a vise to hold work when practical. It's safer than using your hand and it frees both hands to operate the tool.
- **DON'T OVERREACH.** Keep proper footing and balance at all times.

- **MAINTAIN TOOLS WITH CARE.** Keep tools sharp and clean for best and safest performance. Follow instructions for lubricating and changing accessories.
- **ALWAYS DISCONNECT THE MACHINE FROM THE POWER SOURCE BEFORE SERVICING.**
- **REDUCE THE RISK OF UNINTENTIONAL STARTING.** Make sure the switch is in the off position before plugging in.
- **USE RECOMMENDED ACCESSORIES.** Consult the operator's manual for recommended accessories. The use of improper accessories may cause risk of injury to persons.
- **NEVER STAND ON A MACHINE.** Serious injury could occur if the machine tips or if the blade/cutter is unintentionally contacted.
- **CHECK DAMAGED PARTS.** Before further use of the machine, a guard or other part that is damaged should be carefully checked to determine that it will operate properly and perform its intended function - check for alignment of moving parts, binding of moving parts, breakage of parts, mounting, and any other conditions that may affect its operation. A guard or other part that is damaged should be properly repaired or replaced.
- **DIRECTION OF FEED.** Feed work into the cutter against the direction of rotation of the cutter only.
- **NEVER LEAVE THE MACHINE RUNNING UNATTENDED. TURN POWER OFF.** Don't leave the machine until it comes to a complete stop.
- **DO NOT OPERATE** this machine while tired or under the influence of drugs, alcohol, or any medication.

 **WARNING:** This product can expose you to chemicals including lead which is known to the State of California to cause cancer and birth defects or other reproductive harm. For more information go to <http://www.p65warnings.ca.gov>.

 **WARNING:** Drilling, sawing, sanding, or machining wood products generates wood dust and other substances known to the State of California to cause cancer. Avoid inhaling dust generated from wood products or use a dust mask or other safeguards for personal protection.

Wood products emit chemicals known to the State of California to cause birth defects or other reproductive harm. For more information go to <http://www.p65warnings.ca.gov/wood>.

Familiarize yourself with the following safety notices used in this manual:

 **CAUTION**

This means that if precautions are not heeded, it may result in minor injury and/or possible machine damage.

 **WARNING**

This means that if precautions are not heeded, it may result in serious or even fatal injury.

- - SAVE THESE INSTRUCTIONS - -

Electrical Connections

⚠WARNING Electrical connections must be made by a qualified electrician in compliance with all relevant codes. This machine must be properly grounded to help prevent electrical shock and possible fatal injury.

IMPORTANT: Before connecting the saw to power source, be sure the power switch is in *off* position.

115-Volt Operation

When shipped, this shaper is ready for 115V operation and must be grounded. If a malfunction or breakdown occurs, proper grounding reduces the risk of electric shock. This shaper has a grounded three-prong electrical plug.

⚠WARNING You must connect the electrical plug to a properly grounded, three-wire electrical outlet as shown in Figure A. If you do not have a properly grounded, three-wire electrical outlet, you must contact a qualified electrician to install one. Installation must comply with all local codes and ordinances. Do not use this shaper until a properly grounded, three-wire electrical outlet is installed and ready for use.

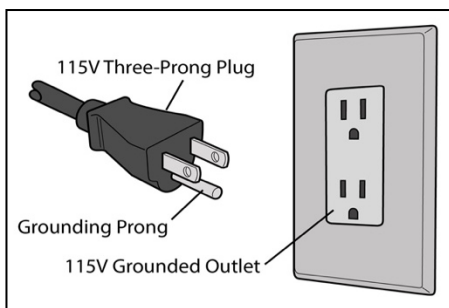

Figure A

⚠WARNING Never use an adapter to connect the three-prong electrical plug to a non-grounded, 2-pole receptacle. Do not modify the plug provided. Improper connection of the grounding conductor can result in a risk of electric shock.

⚠WARNING Check with a qualified electrician or service person if you do not completely understand these grounding instructions or if the proper grounding of this tool is in doubt. Failure to comply may cause serious or fatal injury.

Repair or replace damaged or worn cord immediately.

230-Volt Operation

To convert this shaper to 230V, single phase operation, follow these steps:

1. Disconnect the shaper from the power source.
2. This shaper is supplied with six motor leads. They are connected at the factory for 115V operation, as shown in Figure B. For 230V operation, reconnect these six motor leads as shown in Figure C.
3. **IMPORTANT:** With the leads connected for 230V operation, DO NOT use the 115V electrical plug supplied with the shaper. You must replace the shaper's 115V electrical cord/plug with a UL/CSA-listed cord/plug designed for 230V operation (see Figure D). Contact your local Authorized JET Service Center or a qualified electrician for proper procedures to install the cord/plug. Follow all local and national codes after installing the 230V cord/plug.
4. After installing the 230V cord/plug, only connect to a properly installed 230V electrical outlet. This outlet must have the same configuration as the 230V plug (see Figure D). Never use an adapter to connect the 230V plug to the electrical outlet.

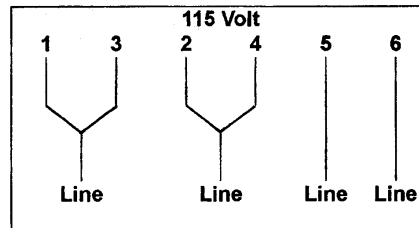

Figure B

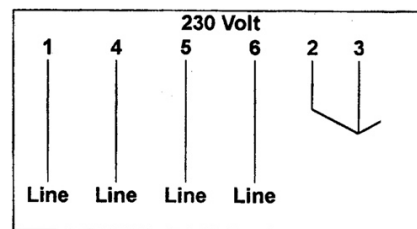

Figure C

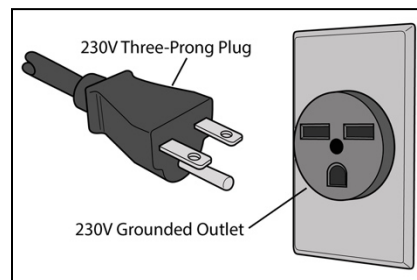

Figure D

Introduction

The JET JWS-20CS woodworking shaper you have purchased is a high-quality machine tool that will give you years of superior service. You will get maximum performance and enjoyment from your new shaper if you will take a few moments now to review the entire manual before beginning assembly and operation. Become familiar with the details of operation.

The JET JWS-20CS, as well as all JET products, are backed by a nationwide network of authorized distributors and/or service centers. Please contact your nearest distributor should you require parts or service. Parts are also available directly from JET by calling 1-800-274-6848.

Now that you have purchased a shaper, it is a good time to consider a dust collection system. See your local JET distributor for the complete line of dust collectors and the full line of JET Dust Collector Hoses and Accessories. Customize your installation and obtain maximum performance with JET dust hoods, hoses, clamps, fittings, and blast gates.

Specifications

Model Number	JWS-20CS
Stock Number	724020
Cutterhead Speed(reversible)(RPM)	8,000 & 10,000 RPM
Table Size (in.).....	18 (L) x 20 (W)
Table Slot (in.).....	3/4 x 3/8 T-slot
Table Opening Diameter (in.).....	5-3/16
Insert Opening Diameter (in.).....	1-5/8 and 3
Fence Size (2) (in.)	10 x 3
Spindle Capacity (in.).....	1/2 and 3/4
Router Bit Collet Capacity (in.).....	1/4 and 1/2
Under Nut Capacity (in.)	1/2" Spindle: 2-3/4 ; 3/4" Spindle: 3
Spindle Travel (in.).....	2
Table Height (in.)	33-1/2
Overall Dimensions (in.).....	18 L x 20 W x 42 H
Dust Chute Diameter (in.)	4
Motor	TEFC, 1 1/2 HP, 1Ph, 115/230V (prewired 115V), 15/7.5 A, 60Hz
Net Weight (approx.).....	201 lbs.
Shipping Weight (approx.)	226 lbs.

The above specifications were current at the time this manual was published, but because of our policy of continuous improvement, JET reserves the right to change specifications at any time and without prior notice, without incurring obligations.

Unpacking and Cleanup

1. Finish removing all contents from the shipping container. Do not discard any shipping material until the shaper is set up and running.
2. Inspect contents for shipping damage and report any damage or missing parts to your distributor.
3. Clean all protected parts with kerosene. Do not use gasoline, paint thinner, or any cellulose-based solvent. These will damage painted surfaces and melt plastic.

Tools Required for Assembly

3mm Angle Wrench
12/14mm Wrench

Contents of the Shipping Container

- 1 Shaper

Accessory Package

- 1 Dust Chute
- 1 Miter Gauge
- 1 Draw Bar & Nut
- 1 1/2" Spindle Assembly
- 1 3/4" Spindle Assembly
- 1 1/4" Router Collet
- 1 1/2" Router Collet
- 1 Arbor Wrench
- 1 3mm Hex Key Wrench
- 1 12mm / 14mm Open End Wrench

Dust Chute Assembly

Install dust chute to the fence body with two 3/8"-16 x 3/4" Hex Cap Screw (A, Fig. 1).

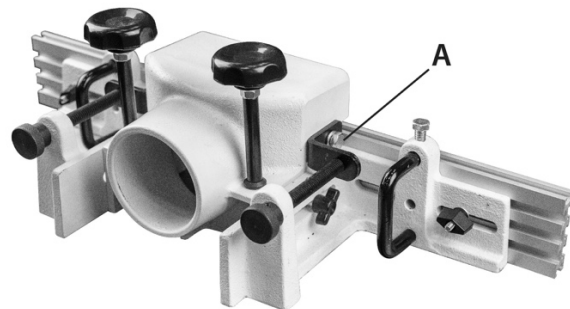

Figure 1

Setup and Adjustments

Spindle Removal and Installation

⚠WARNING All adjustments to the machine must be made with the power off and unplugged from the power source. Failure to comply may result in serious injury.

⚠WARNING The spindle guard has been removed for illustration purposes only! Never operate the shaper without the spindle guard. Failure to comply may result in serious injury.

The arbor is mounted to the main spindle with a draw bar and a nut. Use the following procedure to remove the arbor. Reverse the steps to install the arbor.

1. **Disconnect the machine from the power source.**
2. Loosen spindle lock handle (A, Figure 2). Turn handle counterclockwise to loosen.
3. Raise the lower spindle fully by turning handwheel (B, Figure 2) clockwise. Turn spindle lock handle clockwise to tighten and lock the spindle height.
4. Open the door by turning the latch (A, Figure 3).
5. Pull the spindle locking mandrel out and turn to lock the main spindle (A, Figure 4).
6. Loosen and remove the draw bar nut (B, Figure 4) with a 14mm box wrench or adjustable wrench.
7. Grasp the spindle and remove by pulling up (Figure 5).
8. Remove the draw bar (B, Figure 5) from the spindle.
9. Pull the spindle locking mandrel out and turn to release the main spindle (A, Figure 4).
10. Close the door.

Collet Installation

1. **Disconnect machine from the power source.**
2. Set up the shaper for collet use. Follow steps 1–9 under *Spindle Removal and Installation* (above) to remove the spindle. Clean the spindle taper (A, Figure 5).
3. Raise the spindle fully by turning handwheel clockwise.

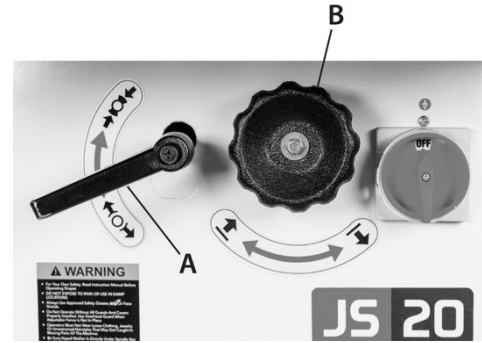

Figure 2



Figure 3

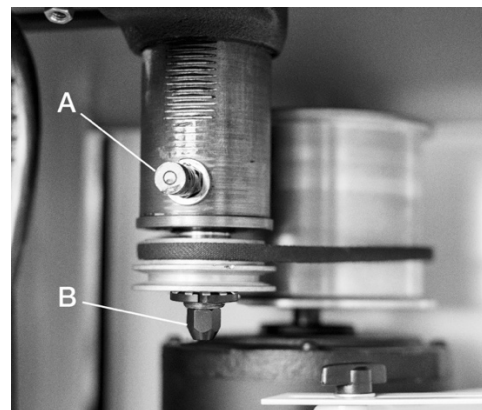

Figure 4

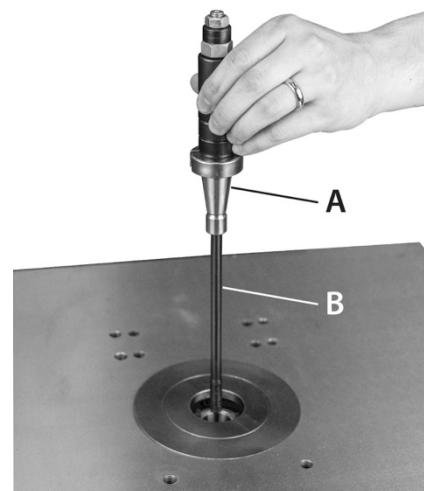

Figure 5

4. Pull the spindle locking mandrel out (A, Figure 4) and turn to lock the main spindle.
5. Place collet assembly with draw bar into the main spindle.
6. Insert a router bit into the collet and tighten the draw bar nut (B, Figure 4).
7. Pull the spindle locking mandrel out and turn to release the main spindle.

Fence Placement and Adjustment

1. To adjust the position of the entire dust chute/fence assembly, loosen and remove the two lock bars (A, Figure 7) from the table. Reposition and align the dust chute/fence assembly over the threaded lock bar holes on the table. Insert the two lock bars through the dust chute housing and tighten into the threaded holes.
2. To adjust fence halves in and out, loosen wing screws (B, Figure 7) and turn knurled knobs (C, Figure 7). When positioned, tighten the wing screws to lock fence halves in place.
3. To adjust the fence widths, loosen the wing knob (D, Figure 7) and move the fence half closer to or farther away from the spindle. When positioned, tighten the wing knob to lock fence in place.
4. Adjust spindle guard (H, Figure 7) height by loosening wing nut (I, Figure 7), sliding guard up or down to desired height, and then tightening wing nut.
5. Adjust spindle guard depth by loosening two lock knobs (J, Figure 7), moving spindle guard to desired position, and then tightening two lock knobs.
6. To adjust guide plate position and height (E, Figure 7), loosen hex cap screw (F, Figure 7). Slide guide support bar (G, Figure 7) in or out and rotate to adjust guide plate height. When positioned, tighten hex cap screw.

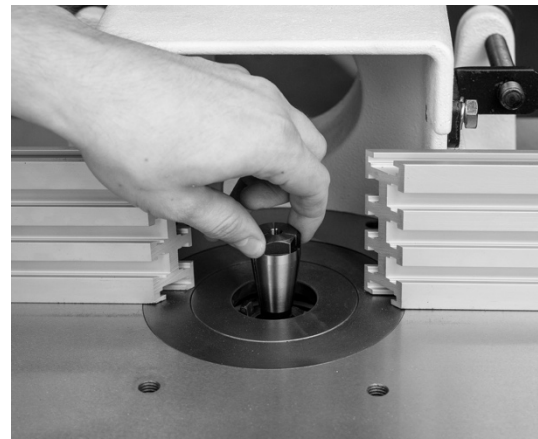

Figure 6

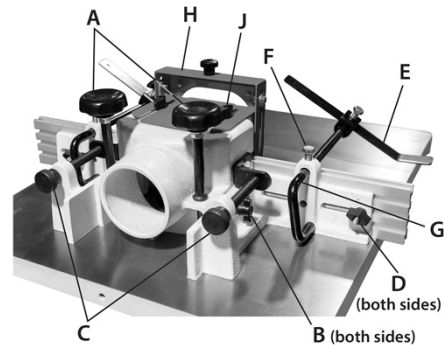
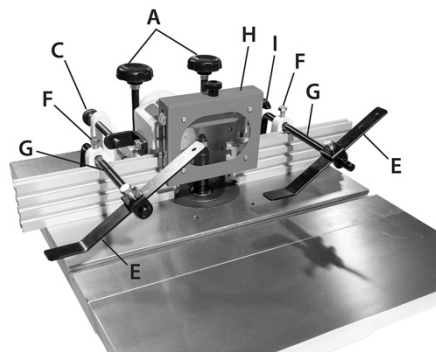

Figure 7

Table Ring Removal and Installation

To remove the table insert(s):

1. Remove any collet or spindle assembly in the spindle.
2. Lower the spindle assembly completely.
3. Loosen and remove the three 1/4-20 x 1/2 set screws from the ring (Figure 8).
4. Lift ring.
5. Align screw holes and install the rings back into the table.

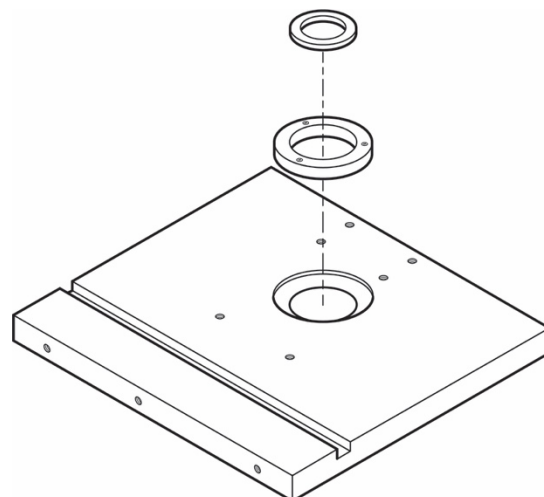

Figure 8

Operation

Spindle Control

To raise or lower spindle:

1. Loosen spindle lock handle (A, Figure 9). Turn handle counterclockwise to loosen.
2. Raise or lower spindle to desired height by turning handwheel (B, Figure 9).
3. Turn spindle lock handle clockwise to tighten.

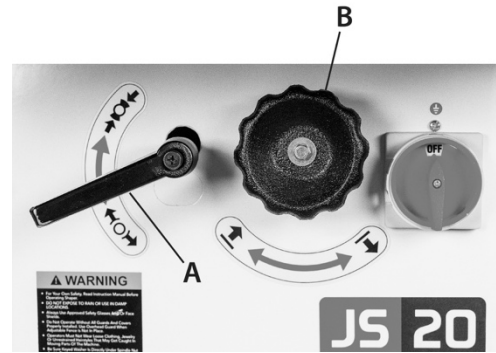

Figure 9

Using the Fence as a Guide

Shaping with the fence is the safest and most satisfactory method of working. This method should always be used when work permits. Almost all straight work can be used with the fence.

1. For most work, where a portion of the edge of the work is not touched by the cutter, both the front and rear fences are in a straight line, as shown in Figure 10.
2. When removing the entire edge of the work piece (i.e., jointing or making a full bead), the shaped edge will not be supported by the rear fence when both fences are in line (see Figure 11). In this case, the work piece should be advanced to the position shown in Figure 11 and stopped.
3. Advance the rear fence to contact the work as shown in Figure 12. This places the rear fence in line with the cutting circle.

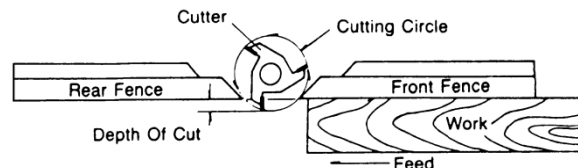

Figure 10

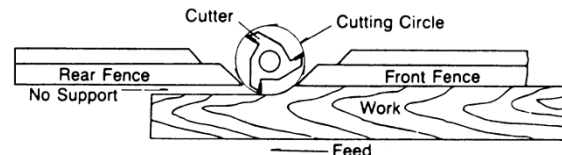

Figure 11

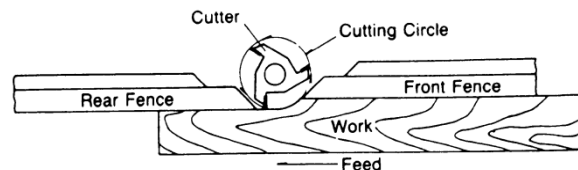

Figure 12

Shaping with Collars and Starting Pin

Follow these rules when shaping with collars and starting pin for safest operation and best results:

1. Collars must be smooth and free from all gum or other substances.
2. The edge of the work must be smooth. Any irregularity in the surface which rides against the collar will be duplicated on the shaped surface.
3. A portion of the work's edge must remain untouched by the cutter so that the collar will have sufficient bearing surface. See Figure 13 for an example of insufficient bearing surface. Figure 14 shows sufficient bearing surface.
4. The work must be heavy in proportion to the cut being made (see Figure 15). Under no circumstances should a small workpiece be shaped against the collars as shown in Figure 16.

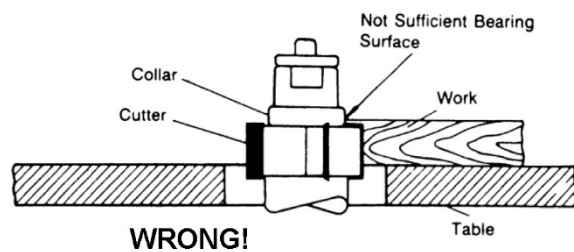

Figure 13

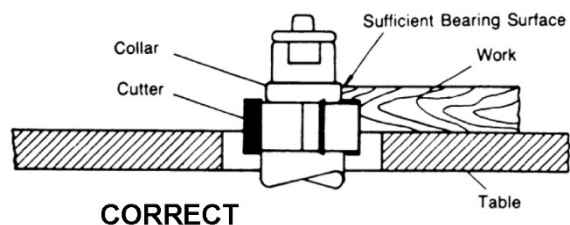

Figure 14

Collar Positioning

Collars may be positioned above, below, or between two cutters:

1. When using the collar below the cutter (Figure 17), you can always observe the progress of the cut. A disadvantage of this method is any accidental lifting of the work will gouge the wood and ruin the workpiece.
2. Using the collar above the cutter (Figure 18), the cut is not affected by slight variations in the stock's thickness. However, the cut is not visible during the operation. Another advantage is accidental lifting of the work piece will not gouge the work piece. Simply correct the mistake by repeating the operation.
3. The collar between cutters method (Figure 19) has both the advantages and disadvantages of the first two methods. This method is used primarily when shaping both edges of the work piece.

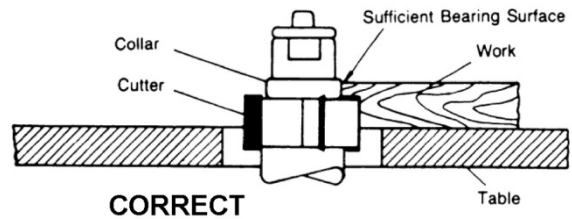

Figure 15

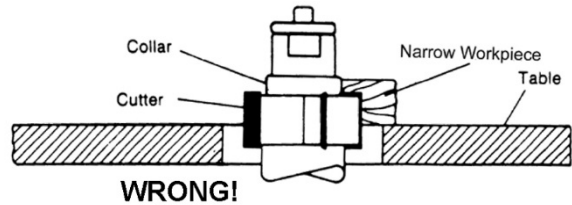

Figure 16

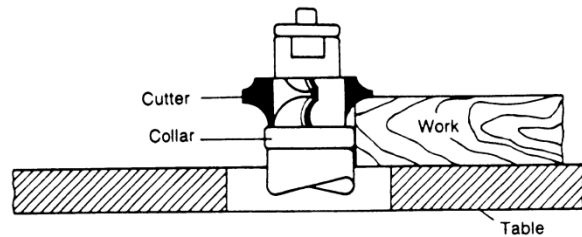

Figure 17

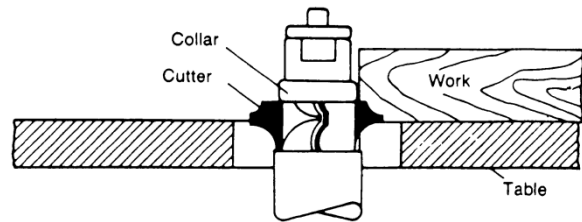

Figure 18

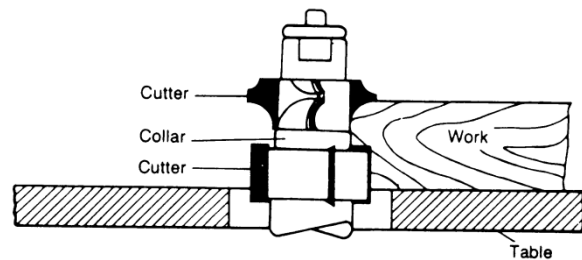

Figure 19

Starting Pin

⚠WARNING Only experienced, advanced users should attempt starting pin shaping! If you have never used this method, get training from a qualified person who is knowledgeable in starting pin shaping!

Failure to comply may cause serious injury!

Place the starting pin in one of the two threaded holes in the table in front of the table rings.

1. Place work piece in the first position using the starting pin as support (see Figure 20). Swing the work into the cutter as shown in the second position. The work is now supported by the collar and starting pin.
2. After starting the cut, swing the work free of the starting pin so it rides only against the collar (see the third position, Figure 21). Always feed against the action of the cutter.

Lubrication

To ensure easy movement when raising and lowering spindle, occasionally apply a drop of light oil on outside of spindle cartridge.

Spindle cartridge bearings are pre-lubricated and sealed. They need no further care.

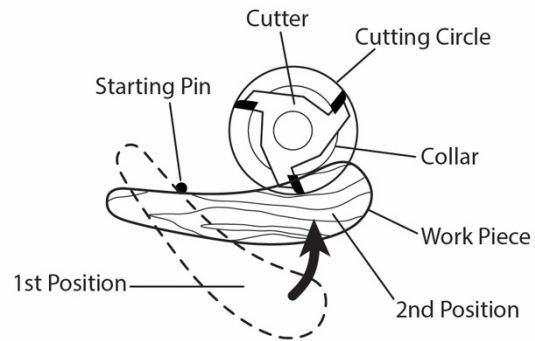

Figure 20

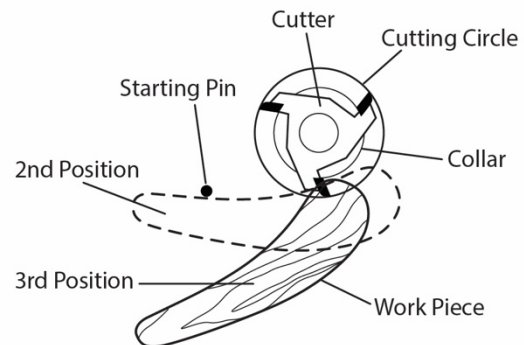

Figure 21

Troubleshooting

Trouble	Probable Cause	Remedy
Shaper will not start.	Cord unplugged from the power source.	Plug in power cord.
	Fuse blown, or circuit breaker tripped.	Replace fuse, or reset circuit breaker.
	Cord damaged.	Replace cord.
	Reversing switch is in the OFF position.	Turn switch to forward or reverse.
	Overload tripped.	Reset overload by depressing red stop button.
Overload kicks out frequently.	Extension cord or wiring inadequate size.	Replace cord or wiring with proper gauge wiring.
	Feeding stock too fast.	Reduce stock feed rate.
	Cutter head is dull.	Use only sharp cutters.
Cutter does not come up to full speed.	Shop wire gauge is too small.	Replace cord or wiring with proper gauge wire.
	Extension cord too light or too long.	Replace with adequate size cord.
	Power source is not adequate.	Contact local electrical utility.
	Motor not wired for correct voltage.	Refer to motor name plate for correct wiring.
	Spindle is locked with mandrel lever.	Unlock spindle - see label next to lever on base.
Cuts are unsatisfactory	Dull cutter.	Replace cutter.
	Gum or pitch on cutter.	Remove cutter and clean with solvent.
	Cutterhead rotating in the wrong direction.	Check for proper rotation at start up.
	Feeding work in the wrong direction.	Feed work against the cutter rotation.
Machine vibrates.	Cutterhead damaged.	Replace cutterhead.
	Stand on uneven surface.	Stand must rest solidly on level surface, bolt to floor if necessary.
	Defective V-belt.	Replace V-belt.
	V-belt incorrectly tensioned.	Apply proper tension.
	Bent pulley.	Replace pulley.
	Motor mounted improperly.	Motor must be properly mounted with snug nuts and bolts.
Edge splits off on cross grain cut.	Characteristic of this type of cut.	Make cross grain cuts first, then finish cut with the grain.
		Use scrap block to support end of cut.
Raised areas on shaped edge.	Variation of pressure holding work against cutter.	Hold work firmly against table and fence. Use hold-downs.

Trouble	Probable Cause	Remedy
Work pulled from hand.	Feeding work in the wrong direction.	Always feed work against the rotation of the cutterhead.
Depth of cut not uniform.	Fence misalignment.	Align outfeed fence.
	Side pressure not uniform.	Use hold-downs; keep constant pressure against fence.
Work burns.	Cutting too deep on one pass.	On hardwoods take light cuts; attain full depth with several passes.
	Forcing work.	Feed work slowly and steadily.
Cut height not uniform.	Variation in pressure holding work to table.	Keep pressure firm throughout pass. Use hold-downs. Make pass slowly and steadily. Keep work under cutter whenever possible.
Cuts not smooth.	Wrong R.P.M.	Use faster speed.
	Feeding too fast.	Slow feed speed.
	Working against the grain.	Work with the grain whenever possible.
	Cutting too deep on one pass.	Take several passes on very deep cuts.
Spindle does not raise freely.	Sawdust or dirt in raising mechanism.	Brush or blow out dirt and saw dust. Lubricate regularly.

Replacement Parts

Replacement parts are listed on the following pages. To order parts or reach our service department, call 1-800-274-6848 Monday through Friday, 8:00 a.m. to 5:00 p.m. CST. Having the Model Number and Serial Number of your machine available when you call will allow us to serve you quickly and accurately.

Non-proprietary parts, such as fasteners, can be found at local hardware stores, or may be ordered from JET. Some parts are shown for reference only and may not be available individually.

JWS-20CS Base Assembly – Exploded View

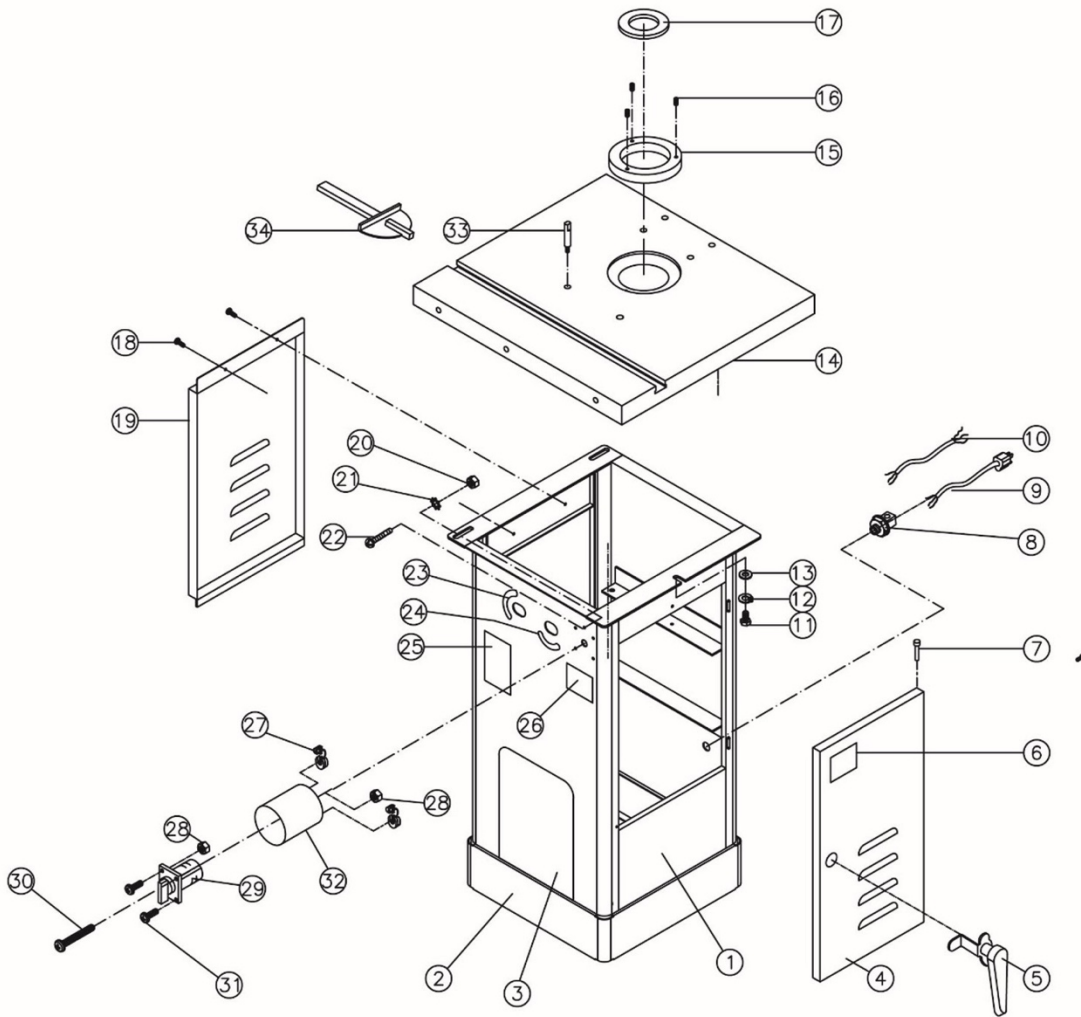

JWS-20CS Base Assembly – Parts List

Index No	Part No	Description	Size	Qty
1	JWS20-101	Cabinet		1
2	JWS20-102	JET Stripe	98mm	1
3	JWS20-103	Name Plate		1
4	JWS20-104	Cabinet Door		1
5	JWS20-105	Handle Assembly		1
6	JWS20-106	I.D. Label		1
7	JWS20-107	Door Pivot		2
8	JWS20-108	Strain Relief		1
9	JWS20-109	Power Cord		1
10	JWS20-110	Motor Cord		1
11	TS-0060031	Hex Cap Bolt	3/8-16 x 3/4	3
12	TS-0720091	Lock Washer	3/8	3
13	TS-0680041	Flat Washer	3/8	3
14	JWS20-114	Table		1
15	JWS20-115	Table Insert		1
16	TS-0267051	Set Screw	1/4-20 x 1/2	3
17	JWS20-117	Table Ring		1
18	TS-081F021	Pan Head Screw	1/4-20 x 3/8	2
19	JWS20-119	Motor Door		1
20	TS-0560071	Hex Nut	#10	1
21	TS-0733031	Tooth Washer	#10	1
22	TS-081C042	Pan Head Screw	#10-24 x 5/8	1
23	JWS20-123	Label (spindle lock)		1
24	JWS20-124	Label (spindle direction)		1
25	JWS20-125	Warning Label		1
26	JWS20-126	Model Decal	JS-20	1
27	JWS20-127	Strain Relief Bushing		2
28	TS-1540021	Hex Nut	M4	4
29	JWS20-129	Forward-Reverse Switch Assembly		1
30	JWS20-130	Pan Head Screw	M4 x 100	2
31	TS-1532052	Pan Head Screw	M4 x 14	2
32	JWS20-132	Switch Box		1
33	JWS25-142	Starting Pin		1
34	JWS20-134	Miter Gauge Assembly		1

JWS-20CS Motor Assembly – Exploded View

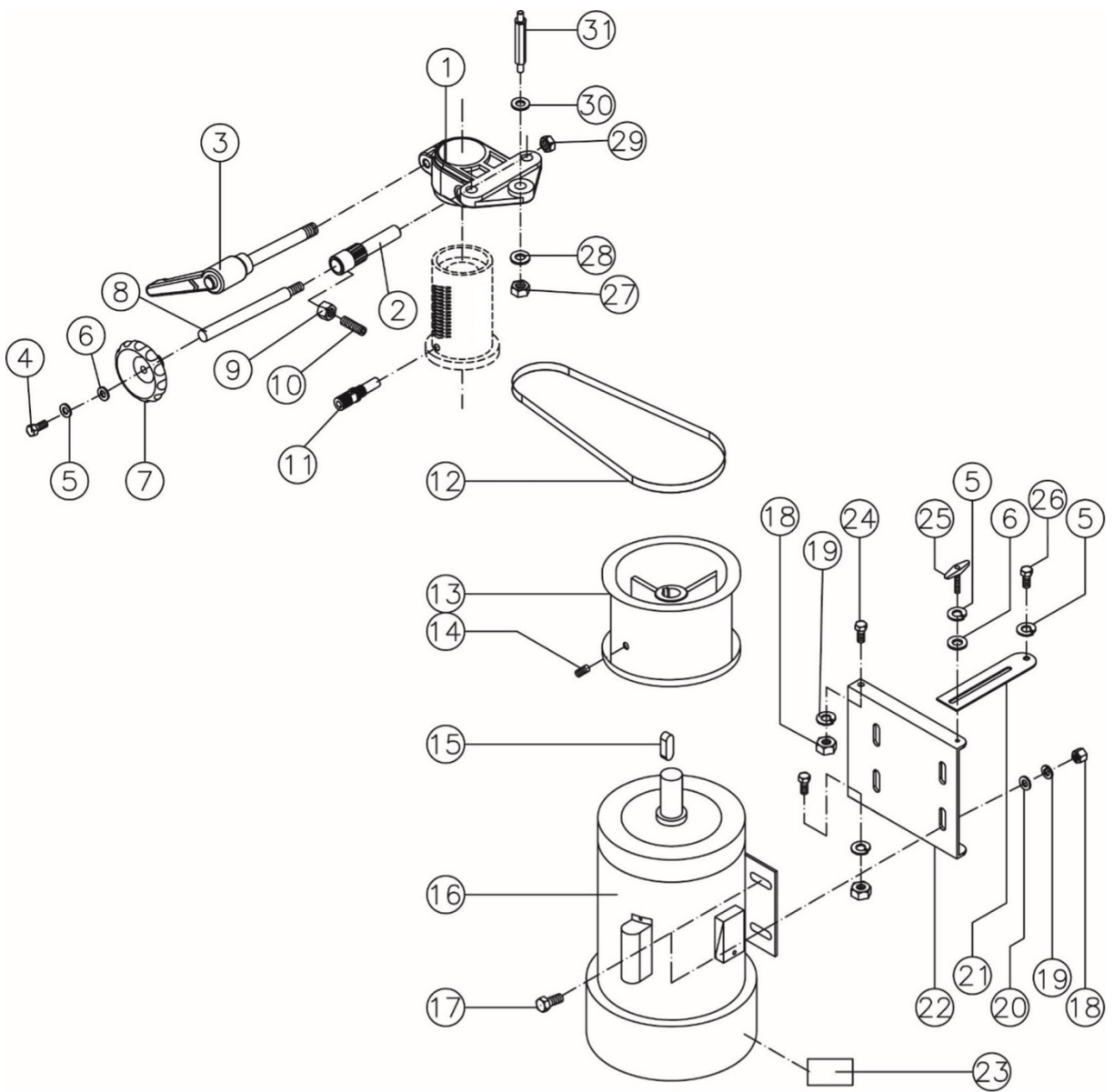

JWS-20CS Motor Assembly – Parts List

Index No	Part No	Description	Size	Qty
1	JWS20-201	Spindle Bracket		1
2	JWS20-202	Gear Shaft		1
3	JWS20-203	Lock Handle		1
4	TS-0050051	Hex Cap Screw	1/4-20 x 1	1
5	TS-0720071	Lock Washer	1/4	3
6	TS-0680021	Flat Washer	1/4	2
7	JWS20-207	Handle Wheel		1
8	JWS20-208	Extension Bar		1
9	TS-0561021	Hex Nut	5/16-18	1
10	TS-0051021	Hex Cap Screw	5/16-18 x 5/8	1
11	JWS20-211	Spindle Lock Assembly		1
12	VB-K23	V-Belt	K-23	1
13	JWS20-213	Motor Pulley		1
14	TS-0267021	Socket Set Screw	1/4-20x1/4	1
15	JWS20-215	Key	5x5x40	1
16	JWS20-216	Motor (Included #23)	1HP, 1Ph 120V/240V	1
	JWS20-216SC	Starting Capacitor	200uf 125VAC	1
17	TS-0152011	Carriage Bolt	5/16-18 x 3/4	4
18	TS-0561021	Hex Nut	5/16-18	6
19	TS-0720081	Lock Washer	5/16	6
20	TS-0680031	Flat Washer	5/16	4
21	JWS20-221	Motor Plate Bracket		1
22	JWS20-222	Motor Plate		1
23	JWS20-223	Motor Label		1
24	JWS20-224	Hex Cap Screw	5/16-18 x 3/4	2
25	JWS20-225	Knob	1/4-20 x 1/2	1
26	JWS20-226	Hex Cap Screw	1/4-20 x 1/2	1
27	6296083	Hex Nut	1/2-12	3
28	JWS20-228	Lock Washer	1/2	3
29	TS-0640112	Nylon Nut	1/2-20	1
30	TS-0680061	Flat Washer	1/2	3
31	JWS20-231	Bolt		3

JWS-20CS Spindle Assembly – Exploded View

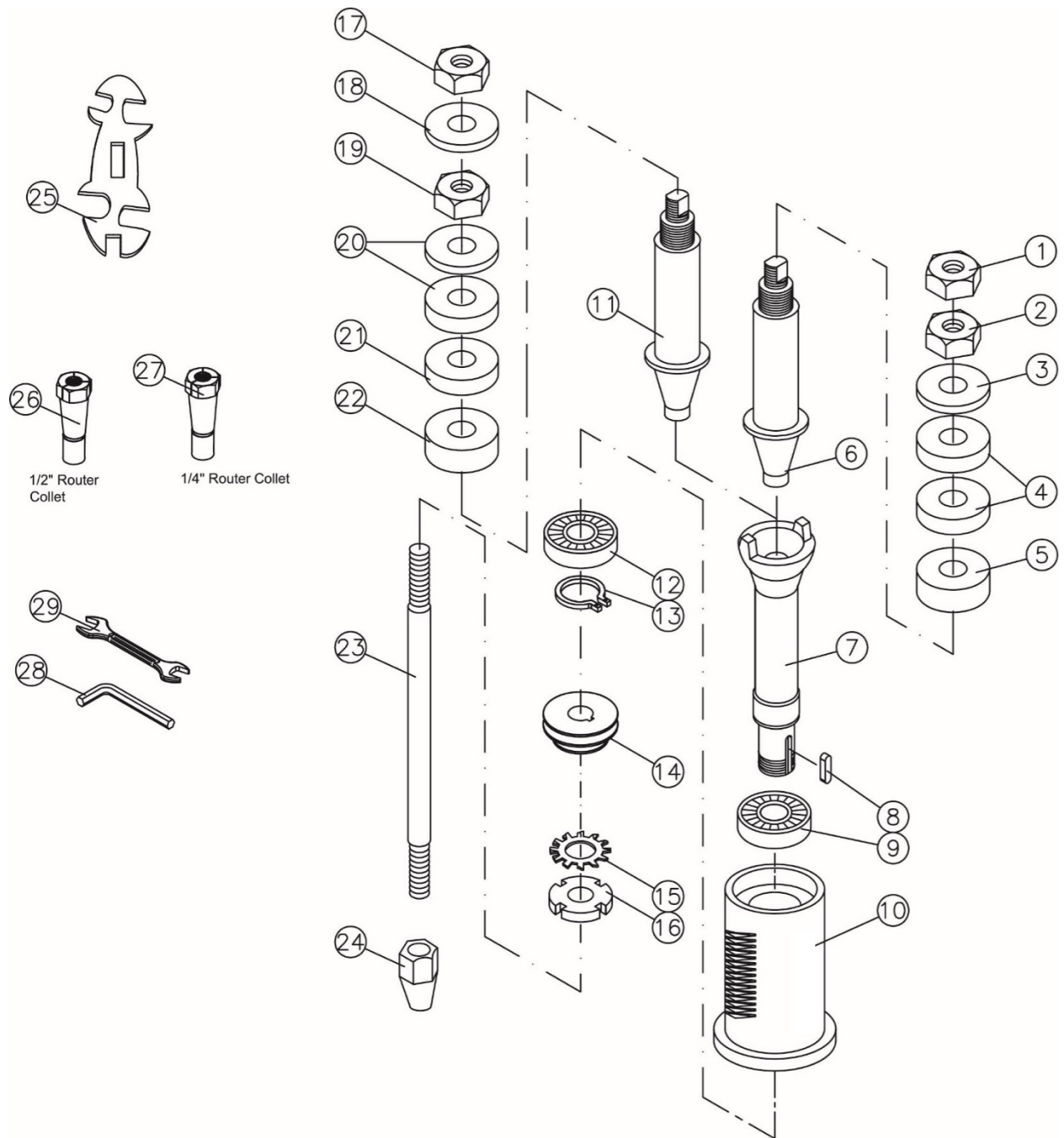

JWS-20CS Spindle Assembly – Parts List

Index No	Part No	Description	Size	Qty
1	JWS25-301	Hex Nut	5/8 L.H.	1
2	JWS25-302	Hex Nut	3/4 R.H.	1
3	JWS25-303	Spacer	3/4x1/2	1
4	JWS25-304	Spacer	3/4x3/4	2
5	JWS25-305	Spacer	3/4x1	1
6	JWS20-306	Spindle Assembly (#1 thru #6)	3/4"	1
7	JWS20-307	Main Spindle		1
8	JWS25-308	Key	5 x 5 x 16	1
9	BB-6005VV	Ball Bearing	6005LLB	1
10	JWS20-310	Spindle Housing		1
11	JWS20-311	Spindle Assembly (#11&17 thru #22)	1/2"	1
12	6005ZZ	Ball Bearing	6005ZZ	1
13	JWS25-313	Snap Ring	S-25	1
14	JWS20-314	Pulley		1
15	JWS20-315	Bearing Lock Washer		1
16	JWS20-316	Bearing Lock Nut		1
17	JWS25-317	Hex Nut	3/8	1
18	JWS25-318	Washer		1
19	JWS25-319	Hex Nut	1/2	1
20	JWS25-320	Spacer	1/2 x 1/2	2
21	JWS25-321	Spacer	1/2 x 3/4	1
22	JWS25-322	Spacer	1/2 x 1	1
23	JWS20-323	Draw Bar		1
24	JWS20-324	Taper Nut		1
25	JWS25-325	Arbor Wrench		1
26	709525	1/2" Router Collet		1
27	709524	1/4" Router Collet		1
28	TS-152704	Hex Key Wrench	3mm	1
29	JJ6CS-OEW2	Open End Wrench	12/14mm	1

JWS-20CS Fence Assembly – Exploded View

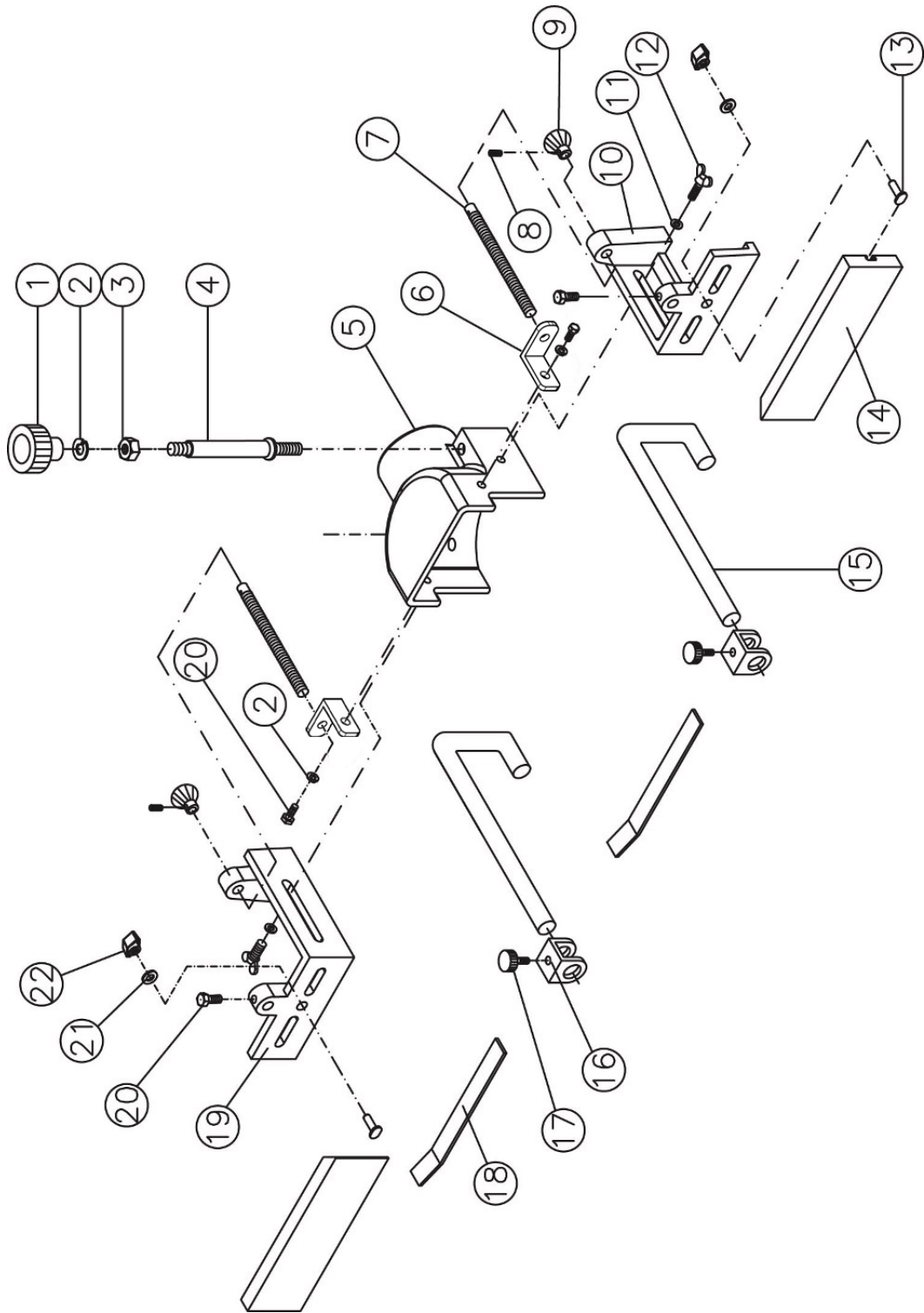

JWS-20CS Fence Assembly – Parts List

Index No	Part No	Description	Size	Qty
1	JWS20-401	Knob		2
2	TS-0720091	Lock Washer	3/8	4
3	TS-0570031	Hex Nut	3/8	2
4	JWS20-404	Lock Bar		2
5	JWS20-405	Dust Chute		1
6	JWS20-406	Bracket Screw Guide		2
7	JWS20-407	Leader Screw		2
8	TS-0267021	Socket Set Screw	1/4-20 x 1/4	2
9	JWS20-409	Knob		2
10	JWS20-410	Bracket Fence	R.H.	1
11	TS-0680041	Flat Washer	3/8	2
12	JWS20-412	Wing Screw	3/8-16 x 3/4	2
13	JWS20-413	T-Bolt	1/4-20 x 1-1/2	2
14	JWS20-414	Aluminum Fence		2
15	JWS20-415	Guide Support		2
16	JWS25-416	Slide Block		2
17	JWS20-417	Knob		2
18	JWS25-415	Guide Plate		2
19	JWS20-419	Bracket Fence	L.H.	1
20	TS-0060031	Hex Cap Screw	3/8-16 x 3/4	4
21	TS-0680031	Flat Washer	5/16	2
22	JWS20-422	Knob		2

JWS-20CS Safety Guard Assembly – Exploded View

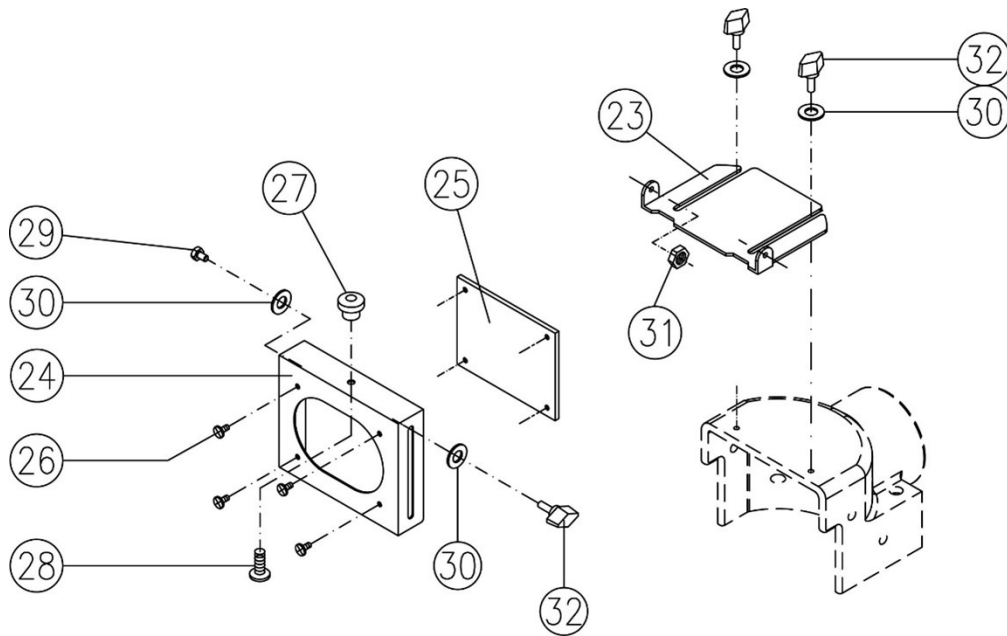

JWS-20CS Safety Guard Assembly – Parts List

Index No	Part No	Description	Size	Qty
	JWS20-SGA	Safety Guard Assembly (Item #23-#32)		1
23	JWS20-623	Sliding Plate		1
24	JWS20-624	Front Guard		1
25	JWS20-625	Transparent Guard		1
26	TS-081C022	Pan Head Screw	#10-24 x 3/8	4
27	JWS20-627	Knob	1/4	1
28	TS-0813022	Pan Head Screw	1/4-20 x 3/8	1
29	TS-0050011	Hex Head Screw	1/4-20 x 1/2	1
30	TS-0680021	Flat Washer	1/4	4
31	TS-0570011	Hex Nut	1/4-20	1
32	JWS20-225	Knob	1/4-20 x 1/2	3

JWS-20CS Extension Table Assembly (Option) – Exploded View

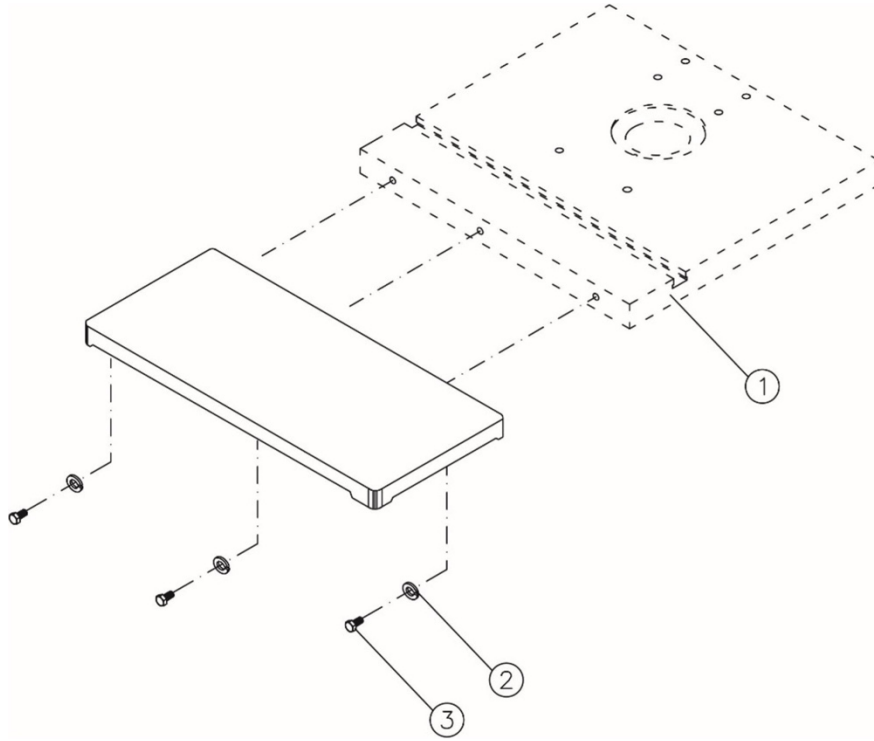

JWS-20CS Extension Table Assembly (Option) – Parts List

Index No	Part No	Description	Size	Qty
.....	724021Extension Table Assembly (#1 thru #3)	1
1	JWS20-501Extension Table	1
2	TS-0060051Hex Cap Screw	3/8-16 x 1	3
3	TS-0720091Lock Washer	3/8	3

JWS-20CS Shaper Electrical Connections

Electrical Schematic

120 Volt

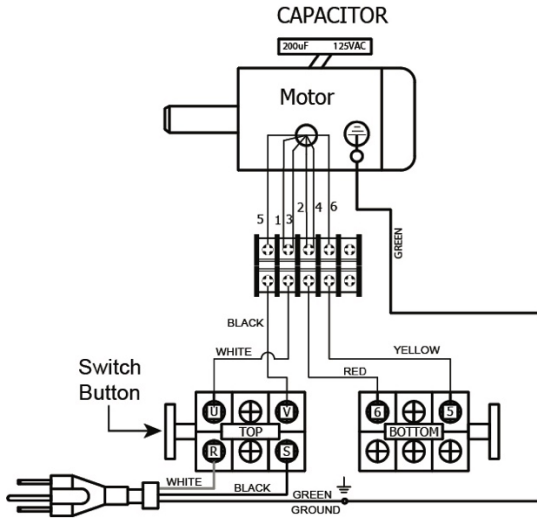

240 Volt

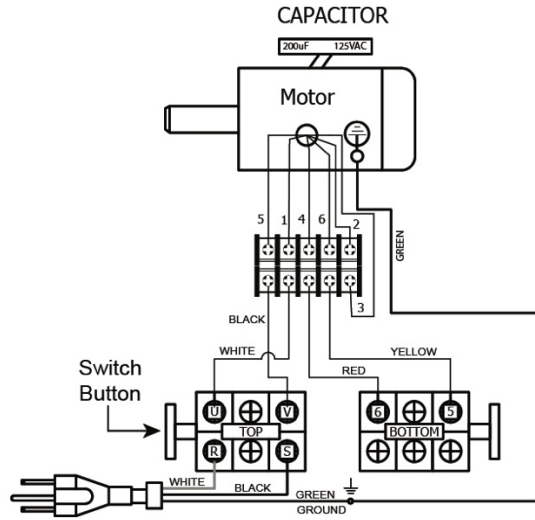

Electrical Schematic for the Forward/Reverse Switch

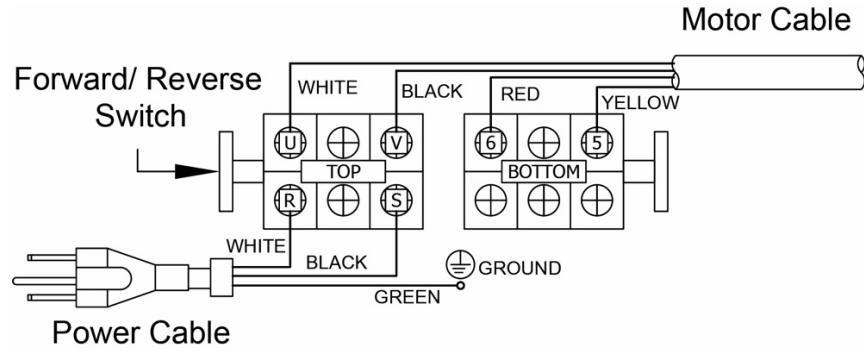



427 New Sanford Road
LaVergne, Tennessee 37086
Phone: 800-274-6848
www.jettools.com