



Operating Instructions and Parts Manual AFS-1000C Air Filtration System



JET
427 New Sanford Road
LaVergne, Tennessee 37086
Ph.: 800-274-6848
www.jettools.com

Part No. M-713000
Edition 2 12/2021
Copyright © 2021 JET



1.0 IMPORTANT SAFETY INSTRUCTIONS

When using an electrical appliance, basic precautions should always be followed, including the following:

READ ALL INSTRUCTIONS BEFORE USING THIS AIR FILTRATION UNIT.

⚠ WARNING To reduce the risk of fire, electric shock, or injury:

1. Read and understand the entire owner's manual before attempting assembly or operation.
2. Read and understand the warnings posted on the machine and in this manual. Failure to comply with all of these warnings may cause serious injury.
3. Replace the warning labels if they become obscured or removed.
4. Do not use this air filtration system for other than its intended use. If used for other purposes, JET disclaims any real or implied warranty and holds itself harmless from any injury that may result from that use.
5. Never duct a machine directly into the air filtration unit.
6. To avoid a potentially dangerous situation, do not use this equipment to filter volatile fumes or smoke.
7. Do not use this equipment to filter flammable vapors. This air filtration unit is designed and intended for the filtration of air borne dust only. It is neither designed nor intended for any other purpose whatsoever.
8. Keep visitors a safe distance from the work area. Keep children away.
9. Make your workshop child proof with padlocks, master switches or by removing starter keys.
10. **DRUGS, ALCOHOL, MEDICATION.** Do not operate tool while under the influence of drugs, alcohol or any medication.
11. Make certain the switch is in the OFF position before connecting the machine to the power supply.
12. Make certain the machine is properly grounded.
13. Use recommended accessories; improper accessories may be hazardous.
14. **GROUND ALL TOOLS.** If tool is equipped with three prong plug, it should be plugged into a three-hole electrical receptacle. If an adapter is used to accommodate a two-prong receptacle, the adapter lug must be attached to a known ground. Never remove the third prong.
15. **WARNING:** Drilling, sawing, sanding or machining wood products generates wood dust and other substances known to the State of California to cause cancer. Avoid inhaling dust generated from wood products or use a dust mask or other safeguards to avoid inhaling dust generated from wood products. Wood products emit chemicals known to the State of California to cause birth defects or other reproductive harm. (California Health and Safety Code Section 25249.6)
16. Keep safety guards, panels, and doors in place, secured, and always closed when the machine is in use. If removed for maintenance purposes, use extreme caution and replace the guards, install the panels and close the doors immediately after completion of maintenance.
17. Maintain tools with care. Keep filters clean for the best and safest performance.
18. Turn off the machine before cleaning. Use a brush or compressed air to remove chips or debris — do not use your hands.
19. Do not use this air filtration unit with a damaged cord or plug. If the unit is not working as it should, has been dropped, damaged, left outdoors, or dropped into water, return it to a service center.
20. When ceiling mounted, bottom of filtration unit must be at least 7 feet from the floor. The mounts must be anchored to building structure which will support the weight of the air filtration unit. Never mount to surfaces such as dry wall or false ceiling grids.
21. When bench top mounted, do not place this unit on an unstable surface, or where there is a risk of tipping over. Serious injury could occur if the unit tips over.
22. To reduce risk of electric shock, do not expose filtration unit to water or rain.
23. Do not use in high humidity environments. Doing so may cause electric shock and/or decreased performance of the unit.
24. **WARNING:** Not suitable for use with solid-state speed controls.
25. Suitable for commercial or industrial use only.

⚠ WARNING: Some dust, fumes and gases created by power sanding, sawing, grinding, drilling, welding and other construction activities contain chemicals known to the State of California to cause cancer and birth defects or other reproductive harm. Some examples of these chemicals are:

- lead from lead-based paint
- crystalline silica from bricks, cement and other masonry products
- arsenic and chromium from chemically treated lumber

Your risk of exposure varies, depending on how often you do this type of work. To reduce your exposure to these chemicals, work in a well-ventilated area and work with approved safety equipment, such as dust masks that are specifically designed to filter out microscopic particles. For more information go to <http://www.p65warnings.ca.gov/> and <http://www.p65warnings.ca.gov/wood>.

This device complies with Part 15 of the FCC Rules. Operation is subject to the following two conditions: (1) this device may not cause harmful interference, and (2) this device must accept any interference received, including interference that may cause undesired operation.

Caution: The user is cautioned that changes or modifications not expressly approved by the party responsible for compliance could void the user's authority to operate the equipment.

Note: This equipment has been tested and found to comply with the limits for a Class B digital device, pursuant to part 15 of the FCC Rules. These limits are designed to provide reasonable protection against harmful interference in a residential installation. This equipment generates uses and can radiate radio frequency energy and, if not installed and used in accordance with the instructions, may cause harmful interference to radio communications. However, there is no guarantee that interference will not occur in a particular installation. If this equipment does cause harmful interference to radio or television reception, which can be determined by turning the equipment off and on, the user is encouraged to try to correct the interference by one or more of the following measures:

- Reorient or relocate the receiving antenna.
- Increase the separation between the equipment and receiver.
- Connect the equipment into an outlet on a circuit different from that to which the receiver is connected.
- Consult the dealer or an experienced radio/TV technician for help.

This device complies with Industry Canada's license-exempt RSSs. Operation is subject to the following two conditions:

- (1) This device may not cause interference; and
- (2) This device must accept any interference, including interference that may cause undesired operation of the device.

Familiarize yourself with the following safety notices used in this manual:

⚠ CAUTION This means that if precautions are not heeded, it may result in minor injury and/or possible machine damage.

⚠ WARNING This means that if precautions are not heeded, it may result in serious, or possibly even fatal, injury.

SAVE THESE INSTRUCTIONS

2.0 Table of contents

Section	Page
1.0 IMPORTANT SAFETY INSTRUCTIONS	2
2.0 Table of contents.....	4
3.0 About this manual	5
4.0 Features	6
5.0 Specifications	7
6.0 Setup.....	9
6.1 Unpacking and cleanup.....	9
6.2 Shipping contents.....	9
6.3 Battery installation	9
6.4 Installation	9
7.0 Electrical connections	10
7.1 GROUNDING INSTRUCTIONS	10
7.2 Extension cords.....	10
8.0 Controls Functions	11
8.1 Control Panel Buttons	11
8.2 RF Remote Control	11
9.0 Operation	12
10.0 User-maintenance	13
10.1 Changing the Filters	13
10.2 Cleaning the Filters	13
10.2.1 Washable Filters.....	13
10.2.2 Dry Filters	14
10.3 RF Remote Control Replacement	14
10.4 Cleaning Sensors	14
10.5 Sensor Replacement.....	14
10.6 Control Board Replacement	14
11.0 Troubleshooting	15
12.0 Replacement Parts.....	16
12.1.1 AFS Unit – Exploded View	16
12.1.2 AFS Unit – Parts List.....	17
12.2.1 Display Module Assembly – Exploded View	18
12.2.2 Display Module Assembly – Parts List	18
12.3.1 Remote Control Assembly – Exploded View.....	19
12.3.2 Remote Control Assembly – Parts List.....	19
13.0 Electrical Connections 115V	20
14.0 Warranty and service	21

3.0 About this manual

This manual is provided by JET, covering the safe operation and maintenance procedures for a JET Model AFS-1000C Air Filtration System. This manual contains instructions on installation, safety precautions, general operating procedures, maintenance instructions and parts breakdown. Your machine has been designed and constructed to provide consistent, long-term operation if used in accordance with the instructions as set forth in this document.

This manual is not intended to be an exhaustive guide to air filtration systems. Additional knowledge can be obtained from experienced users or trade articles. Whatever accepted methods are used, always make personal safety a priority.

If there are questions or comments, please contact your local supplier or JET. JET can also be reached at our web site: www.jettools.com.

Retain this manual for future reference. If the machine transfers ownership, the manual should accompany it.

 **WARNING** Read and understand the entire contents of this manual before attempting assembly or operation! Failure to comply may cause serious injury!

Register your product online -

<http://www.jettools.com/us/en/service-and-support/warranty/registration/>

4.0 Features

- Two-filter system with air diffuser disperses outgoing air into a broader pattern
- Disposable electrostatic outer filter attracts more dust particles than standard filters
- Inner pocket filter is removable for easy cleaning
- Can be either bench-top or ceiling mounted
 - Four eye bolts provided for ceiling mount
- Large easy to read display panel clearly shows:
 - Filter Status
 - Patent Pending system monitors the condition of the filters
 - Bright LED indicators notify the user of the filter status
 - GOOD
 - REPLACE SOON
 - REPLACE
 - Fan Speed – 6 levels
 - Timer setting
 - 1 to 16 hours in 1-hour increments
 - automatically shuts off when timer runs out
- High-efficiency Brushless DC motor
 - Improved durability
 - Quieter operation
 - More energy efficient
- Auto Mode:
 - In Auto Mode the unit monitors ambient air quality using an integrated PM2.5 sensor and adjusts fan speed to compensate
 - More air flow when it's needed to quickly improve air quality
 - Save energy and filter life when dust levels are low
- Patent Pending air flow design not only increases air volume but also decreases noise.
- High strength plastic construction:
 - Reduced weight for ease of installation compared to sheet metal construction
 - Absorbs vibration for quieter operation
 - Impact resistant

5.0 Specifications

Table 1

Model No.	AFS-1000C	
Stock No.	713000	
SPECIFICATION		
Motor:		
Motor type	BLDC (Brushless Direct Current Motor)	
Horsepower	1/3HP	
Phase	3PH	
Electrical:		
Voltage	120V input, single phase only	
Frequency	60Hz	
Listed FLA (full load amps)	3.8 A	
Motor speed range	600~1,100 RPM	
Power cord	SJT 18 AWG x 3C, 6 ft,	
Power plug	American Type NEMA (10A/125V)	
Overload protector	5A	
Performance:		
Fan Speed	Air flow without filter (CFM) ¹	Sound rating @ 1m ¹
1	450 ±10%	51dB
2	560 ±10%	56dB
3	670 ±10%	60dB
4	780 ±10%	63dB
5	890 ±10%	66dB
6	1000 ±10%	67dB
Control Panel:		
On/off switch	Rocker switch	
Speed control	Six selectable speeds	
Timer Setting (Hour)	1 ~ 16 (LED display)	
Display	LED module	
Digital Remote Control:		
Transmitter	Radio Frequency	
Battery	CR2032.3 Volt Button Cell	
Filters:		
Outer Filter (stock # 708731)	5 Micron Replacement Electrostatic Out Filter (carton frame)	
Inner Filter (stock # 708733)	1 Micron Replacement Inner Filter	

Table 1 (cont.)

Dimensions and Weight:	
Overall Dimension (L x W x H/mm)	765 x 615 x 390 /mm
Packing Dimension (L x W x H/mm)	830 x 688 x 490 /mm
Packing Material	Corrugated Box and Styrofoam
Net Weight (lbs.)	33lbs (15 kg)
Gross Weight (lbs.)	41.8lbs (19 kg)

¹ Variable of $\pm 10\%$, for general information only, not to be viewed as fixed parameters for inspection purposes.

L = length, W = width, H = height

n/a = not applicable

The specifications in this manual were current at time of publication, but because of our policy of continuous improvement, JET reserves the right to change specifications at any time and without prior notice, without incurring obligations.

⚠WARNING

Read and understand the entire contents of this manual before attempting assembly or operation. Failure to comply may cause serious injury.

6.0 Setup

6.1 Unpacking and cleanup

Inspect the Air Filtration Unit and check for shipping damage. Report any damage immediately to your distributor and shipping agent. Do not discard any shipping material until the Air Filtration Unit is installed and running properly.

Compare the contents of your container with the following parts list to make sure all parts are intact. Missing parts, if any, should be reported to your distributor.

6.2 Shipping contents

Carton contents

- 1 Air Filtration Unit
- 1 Remote Control
- 1 CR2032 Battery
- 1 Manual and Warranty Card
- 4 Eye Bolts

6.3 Battery installation

1. Remove the battery cover on the rear of the remote control as shown in Fig. 6-1.
2. Install the supplied battery (CR2032) with the "+" side facing upward (Fig. 6-1).
3. Replace the battery cover.

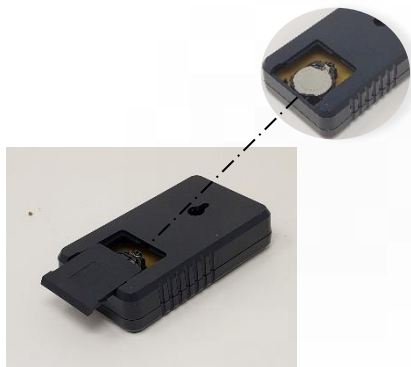

Figure 6-1

6.4 Installation

6.4.1 Overhead (ceiling)

⚠CAUTION

Overhead structure (often ceilings) must be capable of supporting the weight of the air filtration unit and absorbing any vibrations arising from the unit. Appropriate fasteners must be used to secure to the ceiling. Failure to comply may cause serious injury. Never mount to surfaces such as dry wall, false ceiling grids, etc.

When overhead mounting such as a ceiling, make sure chain and ceiling hooks are properly rated for hanging this unit.

Refer to figure 6-2. After noting the direction of air flow, use the hole location dimension to place the anchors in the ceiling so that the chains hang as straight as possible.

Clearance should be at least 7 feet from bottom of unit to the floor.

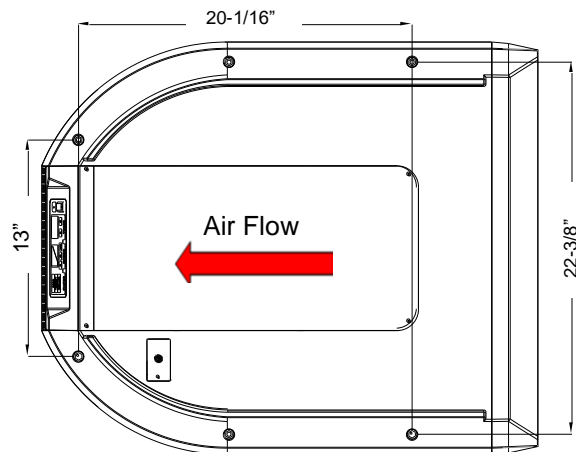

Figure 6-2

This unit will work best if located away from corners and heating/cooling vents.

6.4.2 Benchtop

When bench top mounting is used, make sure that the surface is flat and level and does not allow the AFS to move over the surface which could allow it to fall.

Verify that the bench is stable and secure and will not tip causing the AFS to fall.

In either installation:

- Route the power cord so that it will NOT become entangled in the machine in any way.
- Route the cord to the power supply in a way that does NOT create a trip hazard.

7.0 Electrical connections

⚠WARNING Electrical connections should be made by a qualified electrician in compliance with all relevant codes. Failure to comply may cause serious injury.

The AFS-1000C Air Filtration System is prewired for single phase, 120V power. It is provided with a plug designed for use on a circuit with a grounded outlet that looks like the one pictured in Figure 7-1.

It is recommended that the AFS-1000C be connected to a 15 amp circuit with a circuit breaker or fuse. If fuses are used, they should be time-delay fuse marked "D". **Local codes take precedence over recommendations.**

7.1 GROUNDING INSTRUCTIONS

1. All Grounded, Cord-connected Tools:

This machine must be grounded. In the event of a malfunction or breakdown, grounding provides a path of least resistance for electric current to reduce the risk of electric shock. This tool is equipped with an electric cord having an equipment-grounding conductor and a grounding plug. The plug must be plugged into a matching outlet that is properly installed and grounded in accordance with all local codes and ordinances.

Do not modify the plug provided - if it will not fit the outlet, have the proper outlet installed by a qualified electrician.

Improper connection of the equipment-grounding conductor can result in a risk of electric shock. The conductor with insulation having an outer surface that is green with or without yellow stripes is the equipment-grounding conductor. If repair or replacement of the electric cord or plug is necessary, do not connect the equipment-grounding conductor to a live terminal.

⚠WARNING Check with a qualified electrician or service personnel if the grounding instructions are not completely understood, or if in doubt as to whether the tool is properly grounded. Failure to comply may cause serious or fatal injury.

Use only 3-wire extension cords that have 3-prong grounding plugs and 3-pole receptacles that accept the tool's plug.

Repair or replace damaged or worn cord immediately.

2. Grounded, cord-connected tools intended for use on a supply circuit having a nominal rating **less than 150 volts**:

This tool is intended for use on a circuit that has an outlet that looks like the one illustrated in Figure 7-1.

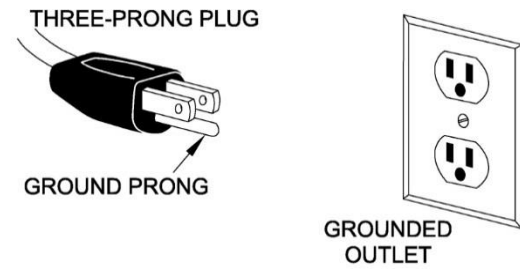

Figure 7-1

7.2 Extension cords

The use of extension cords is discouraged. Try to position machines within reach of the power source. If an extension cord must be used, make sure it is heavy enough to carry the current your product will draw. An undersized cord will cause a drop in line voltage resulting in loss of power and overheating. Table 2 shows correct size to use depending on cord length and nameplate ampere rating. If in doubt, use the next heavier gauge. The smaller the gauge number, the heavier the cord.

Ampere Rating		Volts	Total length of cord in feet			
More Than	Not More Than	120	25	50	100	150
			AWG			
0	6		18	16	16	14
6	10		18	16	14	12
10	12		16	16	14	12
12	16		14	12	Not Recommended	

Extension Cord Recommendations
Table 2

8.0 Controls Functions

8.1 Control Panel Buttons



Figure 8-1

8.2 RF Remote Control

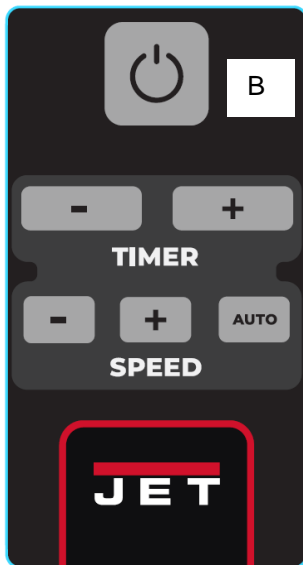

Figure 8-2

POWER ON/OFF SWITCH – A

The Power ON/OFF switch (Fig. 8-1, A) is a rocker switch on the control panel used to supply power to the AFS electronic controls and thus the full AFS.

In the OFF position, AC power is disconnected from the electronics. The AFS unit will Not turn On.

In the ON position, AC power is connected to the electronics. The electronics are powered On in a STANDBY state awaiting user input via the ON/OFF button on either the control panel or the remote.

ON/OFF BUTTON (control panel or remote) – B

The On/Off Button (Fig. 8-1 and 8-2, B) on the controls and the remote perform the exact same function under the exact same conditions.

When the Power switch (Fig. 8-1, A) is first turned ON, power is supplied to the electronics and the AFS unit is in the STANDBY state. All DISPLAYs are off.

Each press of the ON/OFF button (Fig. 8-1 and 8-2, B) cycles the AFS unit between STANDBY and ON.

Pressing the ON/OFF button once:

- AFS Unit goes to ON state.
- The TIMER DISPLAY is blank.
- The fan starts to run at speed 1.
- The SPEED DISPLAY shows 1 bar for speed 1.
- The FILTER DISPLAY will illuminate the filter status.

Pressing the ON/OFF button again does the following:

- AFS unit goes to STANDBY state.
- All DISPLAYs are off, and the fan stops.

TIMER (control panel or remote)

The TIMER buttons (Fig. 8-1 and 8-2) on the controls and the remote perform the exact same function under the exact same conditions.

The TIMER may be set in 1-hour increments from 1 to 16 hours. When the timer expires, the fan will stop and the AFS will enter STANDBY state.

When the timer is not being used, the TIMER display will be blank and the AFS will run continuously until the user changes the settings or stops the AFS.

To activate the TIMER, pressing the TIMER + button.

- The TIMER DISPLAY changes from blank to display flashing “1”. This is 1 hour.
- Pressing the TIMER + button again will increase the number by 1 each time the TIMER + button is pressed. Up to a maximum of 16 hours.
- Pressing the TIMER – button will decrease the number by 1 each time the TIMER - button is pressed. Down to a blank display turning the TIMER Off and running the AFS continuously.
- If the display is already set and showing an hour time value, then pressing the TIMER + or – button will add or subtract time from the already set value.
- When the TIMER + or – button have been pressed, the number on the TIMER display will flash for 1 second and then show steady ON. Steady ON indicates the TIMER is set and the countdown has begun.
- Pressing and holding either the TIMER + or – button (2 seconds) will advance the count quickly (changing every 0.2 seconds) until the button is released.

FAN SPEED ADJUSTMENT (control panel or remote)

The SPEED Buttons (Fig. 8-1 and 8-2) on the controls and the remote perform the exact same function under the exact same conditions.

The SPEED display uses illuminated bars to indicate which speed level is active. The upper most illuminated bar is the current speed setting. The bars not lit are still available to increase fan speed if desired.

Air flow at each fan SPEED setting is as follows:

Fan Speed Setting	CFM
1	450 ±10%
2	560 ±10%
3	670 ±10%
4	780 ±10%
5	890 ±10%
6	1000 ±10%

Table 3

When the AFS is turned ON, the fan will start and run at SPEED 1 until changed by the user. The SPEED display will show 1 bar.

- Pressing the SPEED + button will increase the fan speed.
- Pressing the SPEED – button will decrease the fan speed.

AUTOMATIC MODE

NOTE: For best performance in AUTO mode, allow adequate air flow to the sensor on the bottom of the unit (see Fig. 8-3).

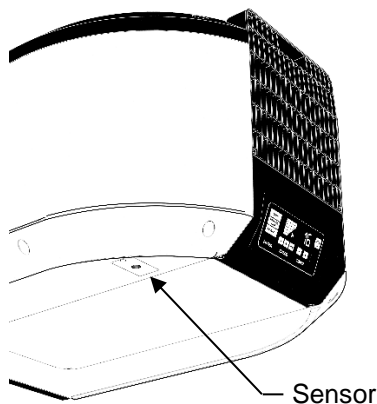

Figure 8-3

The AUTO buttons (Fig. 8-1 and 8-2) on the controls and the remote perform the exact same function under the exact same conditions.

When the AUTO button is pressed, the AUTO button is illuminated, and the AFS is operating in AUTO mode.

In AUTO mode, the integrated sensor detects the air quality and adjusts the fan speed accordingly. Thereby reducing energy consumption when air quality is good and increasing the fan speed when dust is present.

- Pressing either the SPEED + or – button will deactivate AUTO mode and return to manual mode.

NOTE: In AUTO mode the unit may require several minutes to return to fan speed 1 once dust is detected. The unit intentionally ramps down slowly to ensure good shop air quality.

FILTER STATUS INDICATOR (control panel)

The FILTER status indicators are located on the control panel and are there to indicate the condition of the filters.

"GOOD" indicates that the filters are clean enough to provide effective filtration.

"REPLACE SOON" indicates that the filters are becoming clogged, reducing the units ability to effectively filter the shop air, and therefore will need to be cleaned/replaced soon.

"REPLACE" indicates that the filter is clogged to the point that it needs to be cleaned or replaced.

9.0 Operation

NOTE: The Air Filtration Unit is designed to remove airborne non-metallic dust particles; it is not designed to take the place of a dust collection system.

Larger particles are trapped by the outer filter. Smaller particles are stopped by the fine mesh pockets of the inner filter. The air is then exhausted through the diffusion filter, which has a fibrous composition to help diffuse the air.

Normal operation:

- At the Control panel, place Power On/Off switch to ON.
- From either the Control panel or Remote, press the On/Off button.
- Set the SPEED as desired or select AUTO.
- If desired, set the TIMER to automatically turn off at a later time.
- At the end of the day/shift/leaving for an extended period of time, press the On/Off button to stop the fan.
- If leaving for a longer period of time such as weekend or vacation, turn the Power switch to Off as well.

10.0 User-maintenance

⚠WARNING Always disconnect power to the machine before performing maintenance. Failure to do this may result in serious personal injury.

10.1 Changing the Filters

⚠WARNING To reduce the risk of injury, disconnect the air filtration system from the power source (unplug) before servicing or changing filters. Failure to comply may cause serious injury!

There are two filters that need to be changed.

Filter life will vary depending on the amount of usage and the environment of your shop. Clogged filters will reduce the amount of air circulation.

1. Lift the filter up and pull outward on the bottom edge to remove the filter.

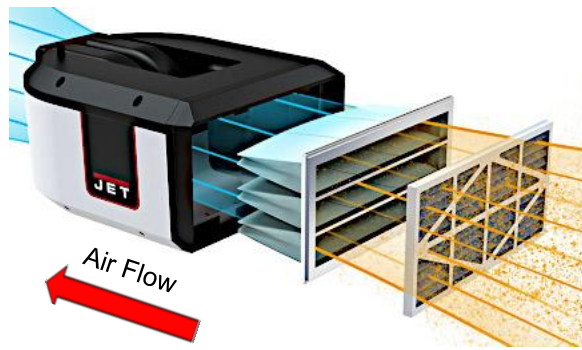

Figure 10-1

2. Remove the *inner filter* by pulling straight out of the cabinet.
3. Remove any protective wrapping from the new filters.
4. Install the filters in reverse of the removal. The outer filter has directional air flow arrows printed on the frame which depicts the direction of air flow. Make sure it is facing the proper direction when installed. If no directional arrows are present, the inboard side of the filter will typically have metal support not used on the outboard side.

Replacement Filters:

NOTE: JET brand filters are recommended for best performance.

708731Electrostatic Outer Filter
708732Washable Electrostatic Outer Filter
708733Inner Three-Pocket Filter
708734 Charcoal Filter

10.2 Cleaning the Filters

⚠WARNING To reduce the risk of injury, disconnect the air filtration system from the power source (unplug) before servicing or changing filters. Failure to comply may cause serious injury!

This AFS is designed to remove airborne non-metallic dust particles from the air. Cleaning is about removing those particles from the filter in the opposite direction from which it came.

It is recommended to clean both filters at the same time. Whether using the Filter Status Indicator or a visual inspection, both filters should be cleaned to restore as much filtration ability as possible.

Remove the filters from the AFS unit as described in 10.1 Changing the Filters.

10.2.1 Washable Filters

Washable filters are those filters which may get wet and allowed to dry before returning to service. The replacement Washable Electrostatic Outer Filter (P/N 708732) is a washable filter.

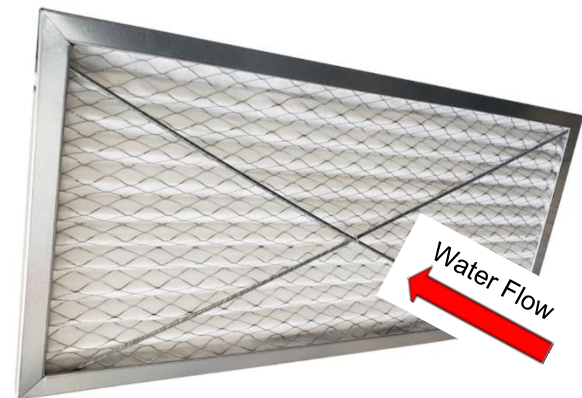

Figure 10-2 Inside of filter shown.

- Using a hose and spray nozzle with normal tap water pressure, spray the filter from the inside out. Opposite the operating air flow. This will rinse the larger loose particles out of the filter.
- Mix a mild detergent and water mixture (soap) such as dish soap. Mix a drop or two of dish soap and water into a spray bottle. If using a commercial electrostatic detergent, follow the label instructions.
- Spray the soap onto the entire filter until fully covered.
- Allow the soap to soak 1 to 2 minutes on the filter but do not allow the soap to dry. This will create a sticky film that is difficult to remove.
- Thoroughly rinse the soap out of the filter and the filter frame.

- Allow all excess water to drain off the filter. While the filter does not need to be absolutely dry, do not return to service if water is dripping or droplets are still visible.
- Low pressure compressed air may be used to remove any remaining water from the filter.
- Install the filters in reverse of the removal. The outer filter has directional air flow arrows printed on the frame which depicts the direction of air flow. Make sure it is facing the proper direction when installed. If no directional arrows are present, the inboard side of the filter will typically have metal support not used on the outboard side.

10.2.2 Dry Filters

Dry filters are those filters which should not get wet. The standard Electrostatic Outer Filter (P/N 708731) is a dry filter.

Cleaning may be completed by vacuuming using a brush attachment on the vacuum hose.

- Lightly brush the vacuum brush nozzle over the input side of the filter. The brush will help dislodge the particles which will then be removed by the vacuum.
- Make several passes moving inline with the pleats of the filter.
- Visually inspect the filter while cleaning. If the filter material is worn, torn, or coming apart from the frame, it must be replaced.

10.3 RF Remote Control Replacement

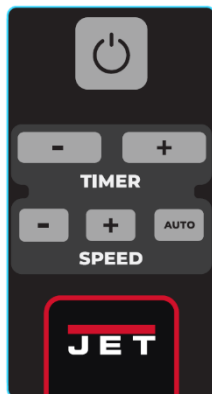

Figure 10-3

The remote control provided with the AFS unit is programmed and ready to operate once the unit is installed. Verify that the batteries are installed in the remote.

Follow these instructions if the remote is being replaced.

1. Place the Power switch in the ON position.

2. DO NOT press the ON/OFF button.
3. Press and hold the SPEED – (minus) and SPEED + (plus) buttons on the control panel at the same time and hold for two seconds. The screen flashes (0.5 seconds) and displays "---" to enter the programming mode.
4. Press and hold the ON/OFF button of the REMOTE control until the panel is turned ON ("ON" is displayed), and the programming is complete.
5. In the programming mode, press any other button on the control panel to exit the programming mode.
6. In the programming mode, if the programming is not completed within seven seconds, you will leave the programming mode.

10.4 Cleaning Sensors

Dust may accumulate on the sensor (see Fig. 8-3) and affect the performance in AUTO mode. Sensor may be cleaned with a dry cloth or compressed air.

10.5 Sensor Replacement

The AFS unit ships from the factory with the sensor and control board calibrated and ready to use. In the event the sensor should need replacing, follow these instructions to calibrate the new sensor:

1. With the Power ON/OFF switch (Fig. 10-4, A) in the OFF position, press and hold the Timer-DN(-) and Timer-UP(+) buttons simultaneously, then switch the Power ON/OFF switch to the ON position to enter the environment value setting mode.
2. The screen flashes and displays "- -", the calibration is completed when the detected value is stable (- - disappears), and then returns to the standby state.



Figure 10-4

10.6 Control Board Replacement

In the event the control board needs replacing, follow the steps in Section 10.5 to calibrate the sensor with the new control board. Then follow these instructions to program the remote to operate with the new control board:

1. Recalibrate the sensor to the new control board.
2. Pair the new control board with the remote control, reference Section 10.3.

11.0 Troubleshooting

Table 4

Symptom	Probable Cause	Remedy
AFS will not start	Power ON/OFF switch in the OFF position	Move Power ON/OFF switch to the ON position.
	No incoming power	Check plug connection Verify there is power at the outlet, check breaker or fuse panel.
	Low voltage	Request voltage check from power company and correct low voltage condition.
	Power cord damaged	Replace power cord.
	Control button or PCBA malfunction	Contact JET customer service.
Excessive vibration	Loose frame, parts, or fasteners	Inspect and tighten as needed.
	Impeller imbalance	Clean impeller (do not use solvents). If imbalance still occurs, replace impeller.
	Motor imbalance	Have motor tested by qualified personnel; replace if needed.
Unit not responding to remote control	Weak batteries in remote	Replace batteries.
	Radio frequency interference	Identify sources of interference and eliminate them or relocate unit.
	Remote control or machine control panel malfunction	Contact JET customer service.
Unit not working efficiently; not cleaning air.	Filter not installed properly	Reinstall filter.
	Blocked air flow	Inspect filter; replace if clogged remove blockage.
Controls on unit not working	Control button or PCBA malfunction	Contact JET customer service.
Timer screen displays numbers / letters other than a countdown timer	If screen displays A8 filter is not installed	Install filter.
	Control may be in factory set-up mode	Move power ON/OFF switch to the OFF position. Wait 30 seconds, then switch back to ON. Then press the On/Off button.
	Loose connection on the control board	Move power ON/OFF switch to the OFF position and unplug the unit. Check the electrical connections to the control board to ensure they are all seated properly.
	Control button or PCBA malfunction	Replace control board. Contact JET customer service.

***Warning:** Some corrections may require a qualified electrician.

12.0 Replacement Parts

Replacement parts are listed on the following pages. To order parts or reach our service department, call 1-800-274-6848 Monday through Friday, 8:00 a.m. to 5:00 p.m. CST. Having the Model Number and Serial Number of your machine available when you call will allow us to serve you quickly and accurately.

12.1.1 AFS Unit – Exploded View

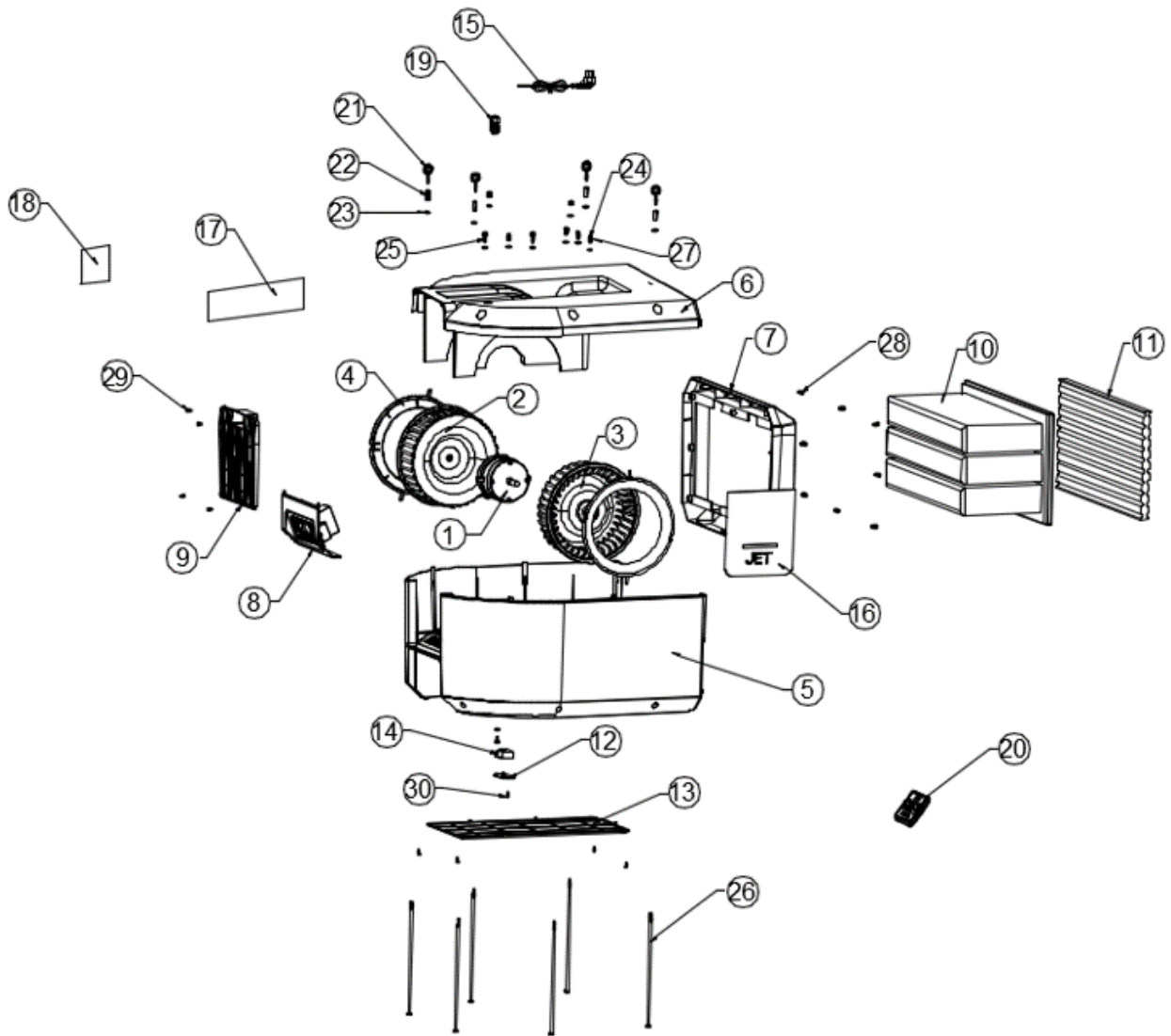

12.1.2 AFS Unit – Parts List

Index No	Part No	Description	Size	Qty
1	AFS1000C-001	Motor		1
2	AFS1000C-002	Fan blade (Right)		1
3	AFS1000C-003	Fan blade (Left)		1
4	AFS1000C-004	Deflector		2
5	AFS1000C-005	Air filter lower case		1
6	AFS1000C-006	Air filter upper case		1
7	AFS1000C-007	Air filter bezel		1
8		Display Module Assembly (SEE 12.2.1 for detail)		1
9	AFS1000C-009	Nets		1
10	708733	Inner three-pocket filter		1
11	708731	Electrostatic outer filter		1
12	AFS1000C-012	Dust sensor cover		1
13	AFS1000C-013	Bottom cover		1
14	AFS1000C-014	Dust sensor		1
15	AFS1000C-015	Power cord		1
16	JET-79B	JET Stripe (7.67"X9.05")		1
17	AFS1000C-MD	Model Decal 1000C		1
18	AFS1000C-018	Warning label		1
19	AFS1000C-019	Cable glands		1
20		Remote Control Assembly (SEE 12.3.1 for detail)		1
21	AFS1000C-021	Eye bolt	M6X20	4
22	AFS1000C-022	Standoff	M6X25	4
23	TS-1550041	Flat washer	M6	13
24	TS-1534032	Screw, Pan Head, Phillips	M6X10	5
25	TS-2286202	Screw, Pan Head, Phillips	M6X20	2
26	AFS1000C-023	Hex head bolt	M6X300	6
27	TS-1551041	Spring washer	M6	7
28	AFS1000C-024	Screw, Pan Head, Phillips (Tapping screw)	M5X12	8
29	AFS1000C-025	Flat head screw (Tapping screw)	M4X10	8
30	AFS1000C-026	Flat head screw (Tapping screw)	M3X10	1
31	AFS1000C-027	Motor Label (not shown)		1
32	AFS1000C-028	ID Label (not shown)		1
33	AFS1000C-029	Energy star Label (not shown)		1
34	AFS1000C-030	Display cable (not shown)		1
35	AFS1000C-031	Dust sensor cable (not shown)		1
36	AFS1000C-HK	Hardware kit includes 4x item 21 (eye bolts) and item 20 (remote control assembly)		1

Replacement Filters:

..... 708731 Electrostatic Outer Filter
..... 708732 Washable Electrostatic Outer Filter
..... 708733 Inner Three-Pocket Filter
..... 708734 Charcoal Filter

12.2.1 Display Module Assembly – Exploded View

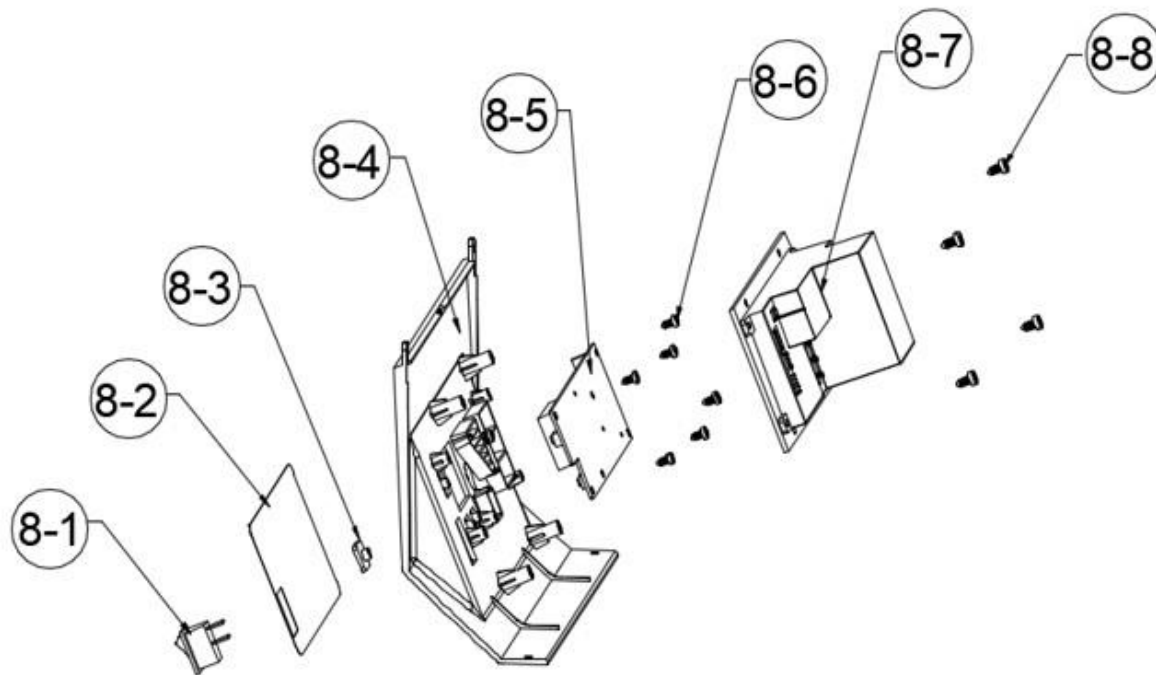

12.2.2 Display Module Assembly – Parts List

Index No	Part No	Description	Size	Qty
8	AFS1000C-DMA	Display Module Assembly		1
8-1	AFS1000C-DM1	AC power switch		1
8-2	AFS1000C-DM2	Display label		1
8-3	AFS1000C-DM3	Auto button		1
8-4	AFS1000C-DM4	Display cover		1
8-5	AFS1000C-DM5	Display PCB		1
8-6	AFS1000C-DM6	Screw, Pan Head, Phillips (Tapping screw)	M3X6	6
8-7	AFS1000C-DM7	Control module		1
8-8	AFS1000C-DM8	Screw, Pan Head, Phillips (Tapping screw)	M4X10	4

12.3.1 Remote Control Assembly – Exploded View

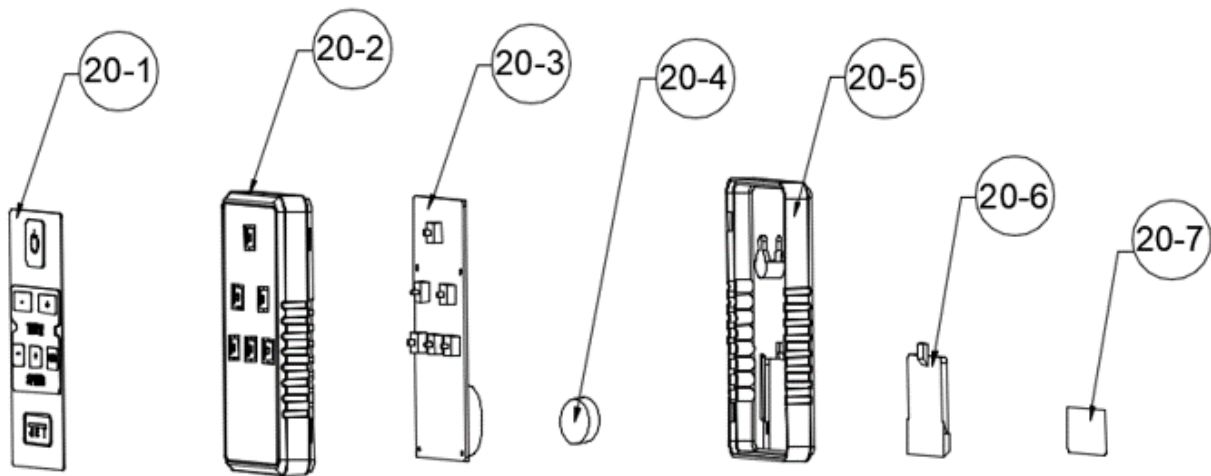

12.3.2 Remote Control Assembly – Parts List

Index No	Part No	Description	Size	Qty
20	AFS1000C-RCA	Remote Control Assembly		1
20-1	AFS1000C-RC1	Remote label		1
20-2	AFS1000C-RC2	Remote front case		1
20-3	AFS1000C-RC3	Remote PCB		1
20-4	AFS1000C-RC4	Button cell	CR2032	1
20-5	AFS1000C-RC5	Remote rear case		1
20-6	AFS1000C-RC6	Battery cover		1
20-7	AFS1000C-RC7	Remote FCC label		1

13.0 Electrical Connections 115V

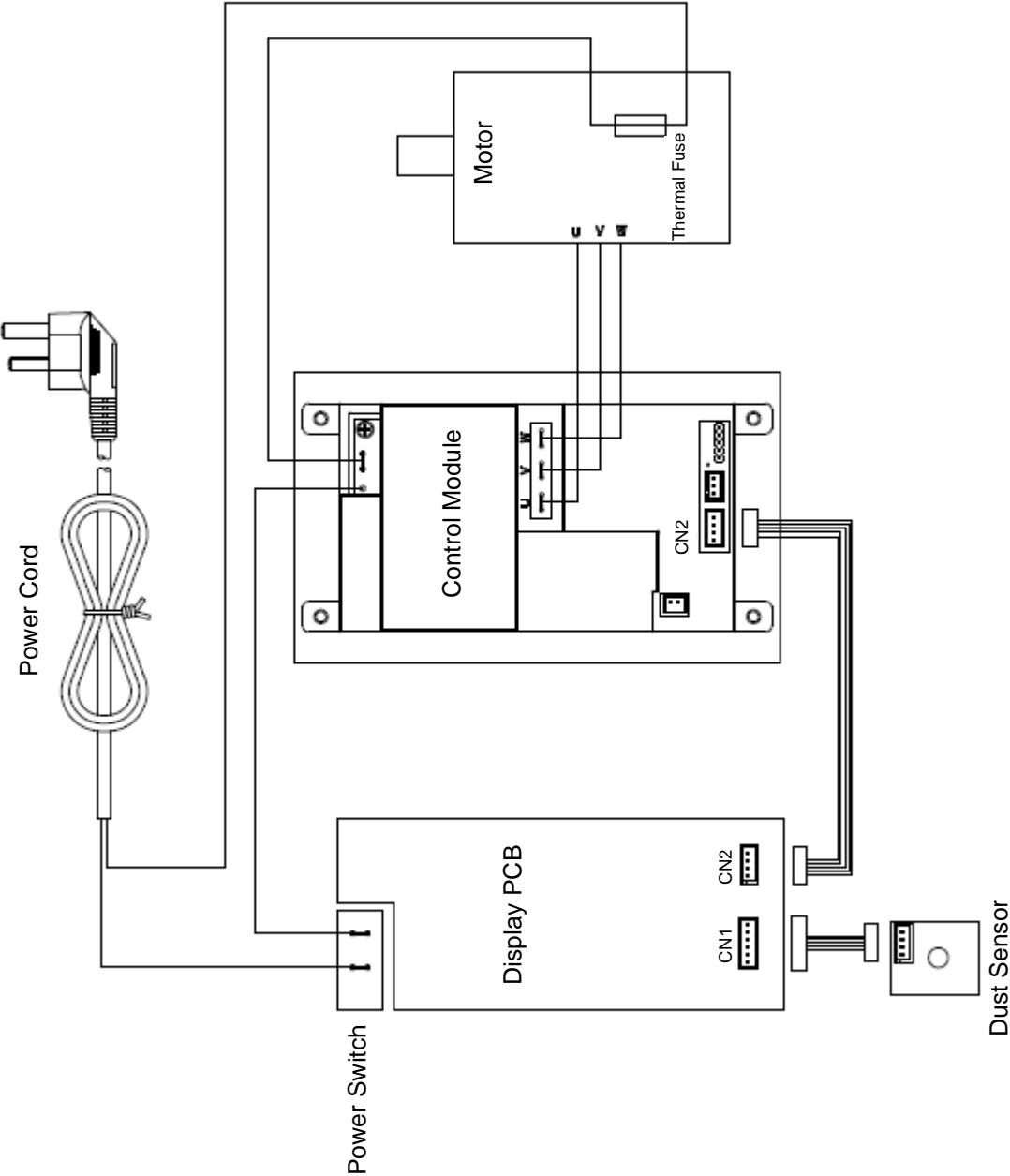

14.0 Warranty and service

JET warrants every product it sells against manufacturers' defects. If one of our tools needs service or repair, please contact Technical Service by calling 1-800-274-6846, 8AM to 5PM CST, Monday through Friday.

Warranty Period

The general warranty lasts for the time period specified in the literature included with your product or on the official JET branded website.

- JET products carry a limited warranty which varies in duration based upon the product. (See chart below)
- Accessories carry a limited warranty of one year from the date of receipt.
- Consumable items are defined as expendable parts or accessories expected to become inoperable within a reasonable amount of use and are covered by a 90 day limited warranty against manufacturer's defects.

Who is Covered

This warranty covers only the initial purchaser of the product from the date of delivery.

What is Covered

This warranty covers any defects in workmanship or materials subject to the limitations stated below. This warranty does not cover failures due directly or indirectly to misuse, abuse, negligence or accidents, normal wear-and-tear, improper repair, alterations or lack of maintenance. JET woodworking machinery is designed to be used with Wood. Use of these machines in the processing of metal, plastics, or other materials outside recommended guidelines may void the warranty. The exceptions are acrylics and other natural items that are made specifically for wood turning.

Warranty Limitations

Woodworking products with a Five Year Warranty that are used for commercial or industrial purposes default to a Two Year Warranty. Please contact Technical Service at 1-800-274-6846 for further clarification.

How to Get Technical Support

Please contact Technical Service by calling 1-800-274-6846. **Please note that you will be asked to provide proof of initial purchase when calling.** If a product requires further inspection, the Technical Service representative will explain and assist with any additional action needed. JET has Authorized Service Centers located throughout the United States. For the name of an Authorized Service Center in your area call 1-800-274-6846 or use the Service Center Locator on the JET website.

More Information

JET is constantly adding new products. For complete, up-to-date product information, check with your local distributor or visit the JET website.

How State Law Applies

This warranty gives you specific legal rights, subject to applicable state law.

Limitations on This Warranty

JET LIMITS ALL IMPLIED WARRANTIES TO THE PERIOD OF THE LIMITED WARRANTY FOR EACH PRODUCT. EXCEPT AS STATED HEREIN, ANY IMPLIED WARRANTIES OF MERCHANTABILITY AND FITNESS FOR A PARTICULAR PURPOSE ARE EXCLUDED. SOME STATES DO NOT ALLOW LIMITATIONS ON HOW LONG AN IMPLIED WARRANTY LASTS, SO THE ABOVE LIMITATION MAY NOT APPLY TO YOU.

JET SHALL IN NO EVENT BE LIABLE FOR DEATH, INJURIES TO PERSONS OR PROPERTY, OR FOR INCIDENTAL, CONTINGENT, SPECIAL, OR CONSEQUENTIAL DAMAGES ARISING FROM THE USE OF OUR PRODUCTS. SOME STATES DO NOT ALLOW THE EXCLUSION OR LIMITATION OF INCIDENTAL OR CONSEQUENTIAL DAMAGES, SO THE ABOVE LIMITATION OR EXCLUSION MAY NOT APPLY TO YOU.

JET sells through distributors only. The specifications listed in JET printed materials and on official JET website are given as general information and are not binding. JET reserves the right to effect at any time, without prior notice, those alterations to parts, fittings, and accessory equipment which they may deem necessary for any reason whatsoever. JET® branded products are not sold in Canada by JPW Industries, Inc.

Product Listing with Warranty Period

90 Days – Parts; Consumable items
1 Year – Motors; Machine Accessories
2 Year – Metalworking Machinery; Electric Hoists, Electric Hoist Accessories; Woodworking Machinery used for industrial or commercial purposes
5 Year – Woodworking Machinery
Limited Lifetime – JET Parallel clamps; VOLT Series Electric Hoists; Manual Hoists; Manual Hoist Accessories; Shop Tools; Warehouse & Dock products; Hand Tools; Air Tools

NOTE: JET is a division of JPW Industries, Inc. References in this document to JET also apply to JPW Industries, Inc., or any of its successors in interest to the JET brand.

NOTES

NOTES



427 New Sanford Road
LaVergne, Tennessee 37086
Phone: 800-274-6848
www.jettools.com