

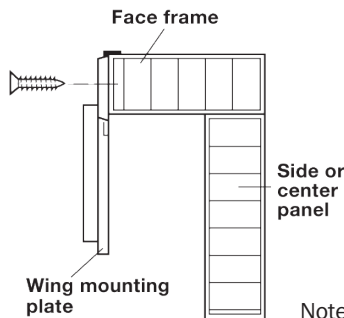

## Häfele A-Series Clip Hinge

Product #152963, 152964



Note: Maximum door thickness 1".

### Hinge Mounting Instructions

- Decide on the number of hinges you want to use and mark their centerline locations on the back of the door (see Figure 1).
- Transfer the centerline to the edge of the face frame.
- Using a 35mm ( $1\frac{3}{8}$ ") forstner bit bore the mounting hole for the hinge cup in the back of the door to a depth of  $\frac{1}{2}$ ". NOTE: Depending on the required reveal (the amount of cabinet edge you wish to leave exposed when the door is closed or the space between the door and cabinet side for inset applications) adjust the *drilling distance* "B" from  $\frac{1}{8}$ " to  $\frac{1}{4}$ " off the edge of the door. To insure the proper operation of the installation we suggest that you make a sample and test the fit before actually boring the finished stock.
- Locate the screw hole centerlines for the mounting clip 37mm from the front edge of the cabinet. Align the center of the mounting plate with the hinge centerline previously marked on the inside of the cabinet and install screws (see Figure 2).
- With the hinges in the open position simply "clip" the arm to the mounting plate and follow the diagram for "three-way" adjustment!

### Number of Hinges per Door

There is no general rule. Obviously this depends on the size and weight of the door. We can give you a rough guide for the more standard applications. In special cases (a door with a mirror) we suggest you conduct a trial for yourself.

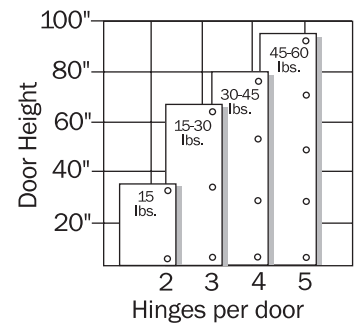

Fig. 1

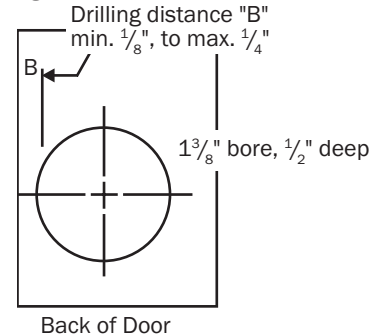
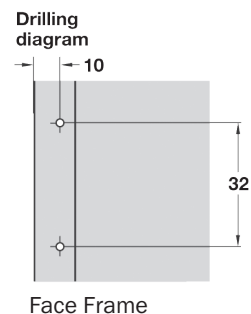
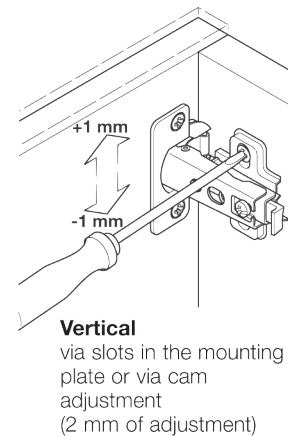
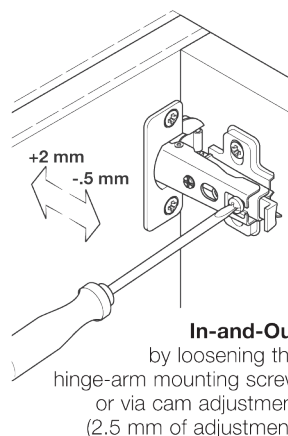
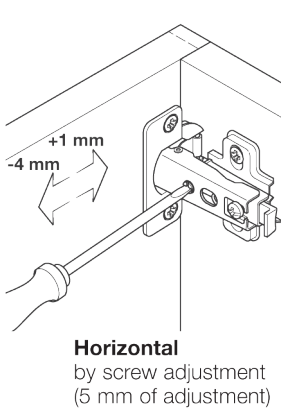

Fig. 2



A Great Advantage: Three independent dimensional adjustments.



Note: Cam Action means that the door is adjusted by simply turning the adjustment screw,