

REVO 18|36 Lathe Manual



LAGUNA TOOLS
2072 Alton Parkway
Irvine, California 92606
Ph: 800.234.1976
www.lagunatools.com

Part No. MLAREVO 1836
© 2018, Laguna Tools, Inc. LAGUNA® and the LAGUNA Logo® are the registered trademarks of Laguna Tools, Inc. All rights reserved.

LAGUNA

Dear Craftsman:

Thank you for your purchase and welcome to the Laguna Tools group of discriminating craftsman. I understand that you have a choice of where to purchase your machines and appreciate the confidence you have in our products.

Every machine sold by Laguna Tools has been carefully designed and well thought through from a woodworker's perspective. I cut on our bandsaws, lathes, table saws, combination machines, and CNC routers and Plasma machines. Through my hands-on experience, I work hard to make our machines better. I strive to give you machines that inspire you to create works of art; machines that are a joy to run and work on; machines that encourage your performance.

Today, we offer high-performance machines with innovative solutions that meet the needs of Craftsman and their ever-evolving craft.

I started Laguna Tools as a woodworker and craftsman; I still am and more.

Thank you again for becoming a Laguna Tools customer.

Torben Helshoj

President and Founder -Laguna Tools

Imagination, Innovation and Invention at Work.

Table of contents.

	Page number
Safety Rules	4
Warranty	9
Noise emission	10
Specification sheet	10
Receiving your machine	11
Introduction to your machine	11
Parts of the machine	11
What you will receive with the machine	16
Where to locate your machine	17
Unpacking your machine	18
Assembly and setup	19
Maintenance	30
Troubleshooting	33
Electrical drawing	35
Exploded view drawings	36

Safety Rules.

"WARNING": For Your Own Safety Read Instruction Manual before Operating Lathe

- (a) Wear eye protection.
- (b) Do not wear gloves, a necktie, or loose clothing.
- (c) Tighten all locks before operating.
- (d) Rotate work piece by hand before applying power.
- (e) Rough out work piece before installing on faceplate.
- (f) Do not mount split work piece or one containing a knot.
- (g) Use lowest speed when starting new work piece.

1. KEEP GUARDS IN PLACE and in working order.
2. REMOVE ADJUSTING KEYS AND WRENCHES. Form habit of checking to see that keys and adjusting wrenches are removed from tool before turning it on.
3. KEEP WORK AREA CLEAN. Cluttered areas and benches invite accidents.
4. DON'T USE IN A DANGEROUS ENVIRONMENT. Don't use power tools in damp or wet locations, or expose them to rain. Keep work area well lighted.
5. KEEP CHILDREN AWAY. All visitors should be kept at a safe distance from the work area.
6. MAKE YOUR WORKSHOP KID PROOF with padlocks, master switches, or by removing starter keys.
7. DON'T FORCE TOOL. It will do the job better and safer at the rate for which it was designed.
8. USE RIGHT TOOL. Don't force tool or attachment to do a job for which it was not designed.
9. USE PROPER EXTENSION CORD. Make sure your extension cord is in good condition. When using an extension cord, be sure to use one heavy enough to carry the current your product will draw. An undersized cord will cause a drop in line voltage resulting in loss of power and overheating. Table A shows the correct size to use depending on cord length and nameplate ampere rating. If in doubt, use the next heavier gauge. The smaller the gauge number, the heavier the cord.
10. WEAR PROPER APPAREL Do not wear loose clothing, gloves, neckties, rings, bracelets, or other jewelry which may get caught in moving parts. Nonslip footwear is recommended. Wear protective hair covering to contain long hair.
11. ALWAYS USE SAFETY GLASSES. Also use a face or dust mask if cutting operation is dusty. Everyday eyeglasses only have impact resistant lenses, they are NOT safety glasses.
12. SECURE WORK. Use clamps or a vise to hold the work when practical. It's safer than using your hand and it frees both hands to operate the tool.
13. DON'T OVERREACH. Keep proper footing and balance at all times.
14. MAINTAIN TOOLS WITH CARE. Keep tools sharp and clean for best and safest performance. Follow instructions for lubricating and changing accessories.
15. DISCONNECT TOOLS before servicing and when changing accessories, such as blades, bits, cutters, and the like.
16. REDUCE THE RISK OF UNINTENTIONAL STARTING. Make sure power switch is in the OFF position before plugging the machine in.
17. USE RECOMMENDED ACCESSORIES. Consult the owner's manual for recommended accessories. The use of improper accessories may cause risk of injury to persons.
18. NEVER STAND ON TOOL Serious injury could occur if the tool is tipped or if the cutting tool is unintentionally contacted.
19. CHECK DAMAGED PARTS. Before further use of the tool, a guard or other part that is damaged should be carefully checked to determine that it will operate properly and perform its intended function - check for alignment of moving parts, binding of moving parts, breakage of parts, mounting, and any other conditions that may affect its operation. A guard or other part that is damaged should be properly repaired or replaced.
20. DIRECTION OF FEED. Feed work into a blade or cutter against the direction of rotation of the blade or cutter only.
21. NEVER LEAVE TOOL RUNNING UNATTENDED. TURN POWER OFF. Don't leave tool until it comes to a complete stop.

Règles de sécurité

"AVERTISSEMENT" : Pour votre sécurité, lire le manuel d'instruction attentivement avant d'utiliser le tour à bois.

- (a) Porter des lunettes de protection.
- (b) Ne pas porter de gants, de cravate, ou de vêtements amples.
- (c) Serrer tous les verrous avant d'opérer la machine.
- (d) Tourner la pièce à la main avant d'appliquer le courant.
- (e) Débiter grossièrement la pièce avant de l'installer sur le plateau de montage.
- (f) Ne pas monter une pièce fendue ou comportant un nœud.
- (g) Utiliser la vitesse la plus lente au démarrage d'une nouvelle pièce.

1. CONSERVEZ TOUS LES DISPOSITIFS DE PROTECTION EN PLACE et en bon état de fonctionnement.
2. ENLEVEZ LES CLÉS ET OUTILS. Prenez l'habitude de vérifier si les clés et autres outils ne sont pas trop près de la machine avant de la démarrer.
3. CONSERVEZ LA SURFACE DE TRAVAIL PROPRE ET LIBRE D'ENTRAVES. Les endroits encombrés augmentent le risque d'accident.
4. NE PAS UTILISER DANS LES ENVIRONNEMENTS DANGEREUX. N'utilisez pas d'outils électriques dans les endroits humides, détrempés, ou sous la pluie. Conservez l'espace de travail bien éclairé.
5. TENEZ LES ENFANTS À L'ÉCART. Tous les visiteurs doivent être tenus à une distance sécuritaire de l'aire de travail.
6. RENDEZ L'ATELIER À L'ÉPREUVE DES ENFANTS avec des verrous, des interrupteurs principaux ou en enlevant les clés de démarrage sur les outils.
7. NE FORCEZ PAS L'OUTIL. L'outil effectuera un meilleur travail et de façon sécuritaire s'il est utilisé au rythme pour lequel il a été conçu.
8. UTILISEZ L'OUTIL APPROPRIÉ. Ne forcez pas un outil ou un accessoire pour effectuer un travail pour lequel il n'a pas été conçu.
9. UTILISEZ UNE RALLONGE ÉLECTRIQUE APPROPRIÉE. Assurez-vous que votre rallonge électrique est en bon état et que le calibre du filage soit adéquat pour transporter le courant que la machine a besoin. Une rallonge de trop faible calibre induira une perte d'intensité du voltage, ce qui provoquera une surchauffe et une perte de puissance. Le tableau A indique le bon calibre à utiliser en fonction de la longueur de la rallonge et de la demande en intensité du moteur. En cas de doute, utilisez la rallonge de calibre plus fort. Plus le numéro est petit, plus la rallonge est de fort calibre.
10. PORTEZ DES VÊTEMENTS APPROPRIÉS. Ne portez pas de vêtements amples, des gants, des colliers, des bracelets, ou tout autre bijou ou accessoire qui pourrait être entraîné par des pièces mobiles. Des souliers à semelle antidérapante sont également recommandés. Attachez les cheveux longs et portez un bonnet pour contenir la chevelure trop abondante.
11. PORTEZ DES LUNETTES DE PROTECTION. Portez également un masque contre la poussière si le travail exécuté dégage de la poussière. Veuillez prendre note que les lunettes de prescription ordinaire ne résistent pas aux impacts et qu'elles ne sont pas homologuées à titre de lunettes de sécurité.
12. IMMOBILISEZ VOTRE TRAVAIL. Utilisez des serres ou un étau pour immobiliser votre travail lorsque c'est possible. C'est plus sécuritaire que d'utiliser votre main, et ça permet de libérer vos deux mains pour opérer l'outil confortablement.
13. NE VOUS ÉTIREZ PAS AU-DESSUS DE LA MACHINE. Demeurez solidement en équilibre sur vos pieds en tout temps.
14. ENTRETENEZ LES OUTILS AVEC SOIN. Gardez les outils de coupe tranchants et propres pour en tirer les meilleures performances. Suivez les instructions du fabricant pour la lubrification et l'entretien des accessoires.
15. DÉBRANCHEZ LES OUTILS avant d'en effectuer l'entretien ou lors du changement d'accessoires tels que lames ou couteaux.
16. RÉDUISEZ LES RISQUES DE DÉMARRAGE NON INTENTIONNEL. Assurez-vous que l'interrupteur est en position fermée avant le branchement d'un outil.
17. UTILISEZ LES ACCESSOIRES RECOMMANDÉS. Consultez le manuel d'instruction pour connaître les accessoires recommandés. L'utilisation d'accessoires inappropriés pose des risques de blessures aux utilisateurs.
18. NE VOUS TENEZ JAMAIS DEBOUT SUR UNE MACHINE. Des blessures graves pourraient survenir si la machine bascule ou si les outils coupants sont touchés accidentellement.
19. VÉRIFIEZ LES PIÈCES ENDOMMAGÉES. Avant de poursuivre l'utilisation d'un outil, tout dispositif de protection ou toute pièce endommagée devra être inspecté pour déterminer si elle peut fonctionner correctement et selon l'utilisation qui en est prévue. Vérifiez l'alignement des pièces mobiles à savoir s'il y a un blocage, un bris, ou toute autre condition qui nuirait à son utilisation. Une pièce ou un protecteur endommagé doit être réparé ou remplacé.
20. SENS D'ALIMENTATION. Alimentez la pièce vers la lame ou le couteau dans le sens contraire de sa rotation seulement.
21. NE LAISSEZ JAMAIS UN OUTIL FONCTIONNER DANS SURVEILLANCE – ÉTEIGNEZ L'OUTIL. Ne laissez pas l'outil sans surveillance jusqu'à ce qu'il s'arrête complètement.

Table A						
Ampere Rating		Volts	Total length of cord in feet			
		120	25	50	100	150
		240	50	100	200	300
More Than	Not More Than		Minimum gage for cord			
0	6		18	16	16	14
6	10		18	16	14	12
10	12		16	16	14	12
12	16		14	12	Not Recommended	

GROUNDING INSTRUCTIONS

1. All grounded, cord-connected tools:

In the event of a malfunction or breakdown, grounding provides a path of least resistance for electric current to reduce the risk of electric shock. This tool is equipped with an electric cord having an equipment-grounding conductor and a grounding plug. The plug must be plugged into a matching outlet that is properly installed and grounded in accordance with all local codes and ordinances.

Do not modify the plug provided - if it will not fit the outlet, have the proper outlet installed by a qualified electrician.

Improper connection of the equipment-grounding conductor can result in a risk of electric shock. The conductor with insulation having an outer surface that is green with or without yellow stripes is the equipment-grounding conductor. If repair or replacement of the electric cord or plug is necessary, do not connect the equipment-grounding conductor to a live terminal.

Check with a qualified electrician or service personnel if the grounding instructions are not completely understood, or if in doubt as to whether the tool is properly grounded.

Use only 3-wire extension cords that have 3-prong grounding plugs and 3 pole receptacles that accept the tool's plug.

Repair or replace damaged or worn cord immediately.

2. Grounded, cord-connected tools intended for use on a supply circuit having a nominal rating less than 150 volts:

This tool is intended for use on a circuit that has an outlet that looks like the one illustrated in Sketch A in Fig. 1. The tool has a grounding plug that looks like the plug illustrated in Sketch A in Fig. 1. A temporary adapter, which looks like the adapter illustrated in Sketch B and C, may be used to connect this plug to a 2 pole receptacle as shown in Sketch B if a properly grounded outlet is not available. The temporary adapter should be used only until a properly grounded outlet can be installed by a qualified electrician. **This adapter is not permitted in Canada.** The green-colored rigid ear, lug, and the like, extending from the adapter must be connected to a permanent ground such as a properly grounded outlet box.

3. Grounded, cord-connected tools intended for use on a supply circuit having a nominal rating between 150 – 250 volts, inclusive:

This tool is intended for use on a circuit that has an outlet that looks like the one illustrated in Sketch D. The tool has a grounding plug that looks like the plug illustrated in Sketch D. Make sure the tool is connected to an outlet having the same configuration as the plug. No adapter is available or should be used with this tool. If the tool must be reconnected for use on a different type of electric circuit, the reconnection should be made by qualified service personnel; and after reconnection, the tool should comply with all local codes and ordinances.

Grounding methods

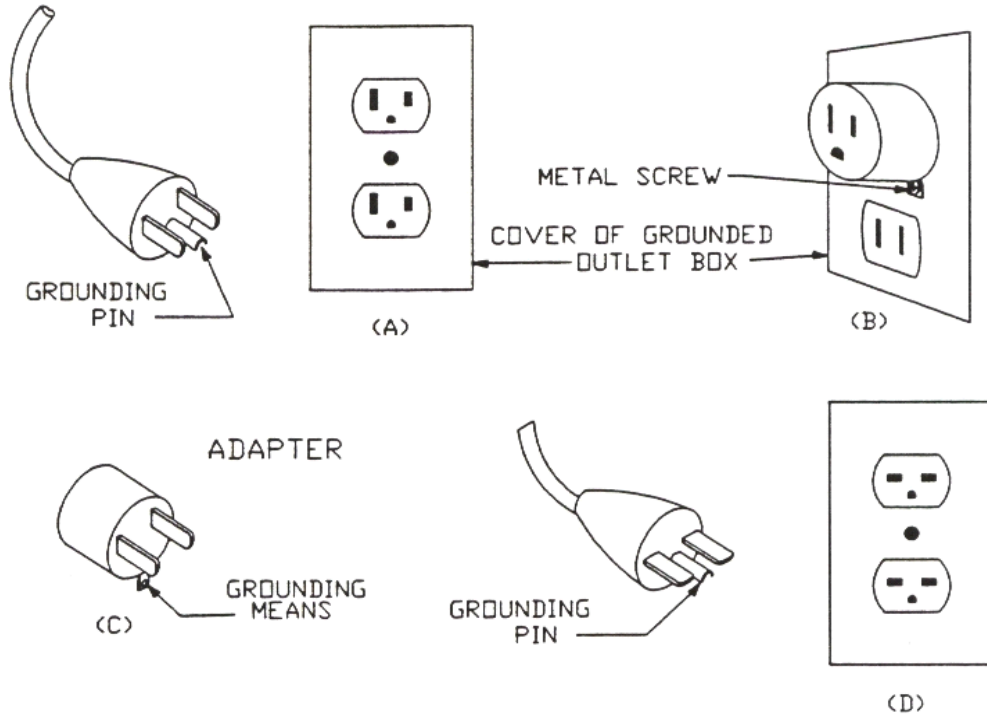

Fig. 1

Locking the lathe

It is strongly recommended that the lathe is never be left unattended in the unlocked condition.

To lock the machine it is recommended that a cover (not supplied) is made to lock the control panel. We have supplied two concepts for locking the panel (see below). The cover can be made from wood or plastic.

First, push down the emergency stop. Then lock the cover together by putting padlocks [not included] on the two handles on the control panel. To safeguard your machine from unauthorized operation and accidental starting by young children, the use of padlocks is strongly recommended.

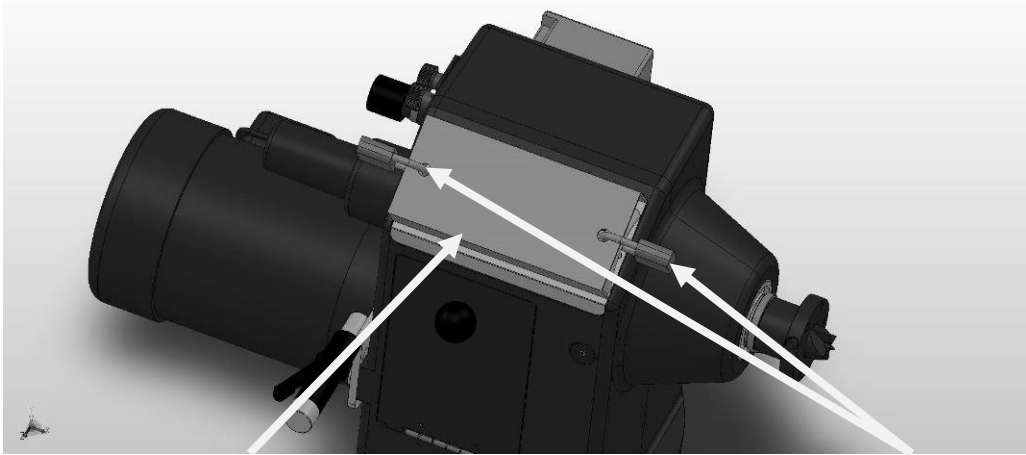

Wooden safety cover

Emergency stop switch

Padlocks

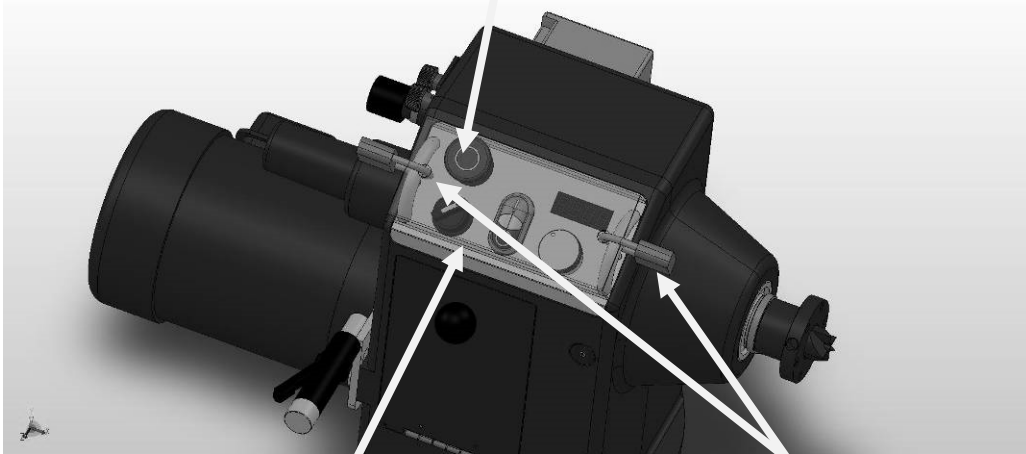

Plastic safety cover

Padlocks

Limited Warranty.

New woodworking machines sold by Laguna Tools carry a one-year warranty from the date of shipping. Laguna Tools guarantees all new machines sold to be free of manufacturer's defective workmanship, parts, and materials.

We will repair or replace, without charge, any parts determined by Laguna Tools, Inc. to be a manufacturer's defect. We require the defective item/part to be returned to Laguna Tools. In the event the item/part is determined to be

damaged due to lack of maintenance, cleaning or misuse/abuse, the customer will be responsible for the cost to replace the item/part, plus all related shipping charges.

This limited warranty does not apply to natural disasters, acts of terrorism, normal wear and tear, product failure due to lack of maintenance or cleaning, damage caused by accident, neglect, lack of or inadequate dust collection, misuse/abuse or damage caused when repair or alterations have been made or attempted by others.

Laguna Tools, Inc. is not responsible for additional tools or modifications sold or performed (other than from/by Laguna Tools, Inc.) on any Laguna Tools, Inc. woodworking machine. Warranty may be voided upon the addition of such noted tools and/or modifications, determined on a case-by-case basis.

Normal user alignment, adjustment, tuning and machine settings are not covered by this warranty. It is the responsibility of the user to understand basic woodworking machinery settings and procedures and to properly maintain the equipment in accordance with the standards provided by the manufacturer.

Parts, under warranty, are shipped at Laguna Tools, Inc's cost either by common carrier, FedEx Ground service or a similar method.

Technical support to install replacement parts is primarily provided by phone, fax, or e-mail. The labor required to install replacement parts is the responsibility of the user.

Laguna Tools is not responsible for damage or loss caused by a freight company or other circumstances not in our control.

Only new machines sold to the original owner are covered by this warranty.

For warranty repair information, call 1-800-332-4094.

Noise Emission.

Notes concerning noise emission:

Given that there exists a relationship between noise level and exposure times, it is not possible to precisely determine the need for supplementary precautions. The factors affecting the true level of exposure to operators are clearly the amount of time exposed and the characteristics of the working environment, such as other sources of dust and noise, etc., for example, adjacent machines - in other words, the level of ambient noise. It is possible that exposure level limits will vary from country to country.

Specification sheet.

Motor	Induction,1725RPM, 2 HP 220V	Induction,1725RPM, 1.5 HP 110V
Voltage	220v 60hz single phase input, 3 phase output	110v 60hz single phase input 3 phase output
Recommended breaker size	15 amp	15 amp
Swing over bed	18" (457mm)	18" (457mm)
Swing over banjo	13.5" (343mm)	13.5" (343mm)
Outboard swing max	32" (813mm)	32" (813mm)
Distance between centers	36" (914mm)	36" (914mm)
Floor to spindle center	41.5"(1054mm)	41.5"(1054mm)
Floor to bed height	32.5" with pads (826mm)	32.5" with pads (826mm)
Floor space	W60" D26" H47"(1524mm, 660mm, 1194mm)	W60" D26" H47"(1524mm, 660mm, 1194mm)
Tool rest	12" (305mm)	12" (305mm)
Speed range high	135 - 3500 RPM	135 - 3500 RPM
Speed range low	50 - 1300 RPM	50 - 1300 RPM
VFD	DeltaS1 variable frequency drive	DeltaS1 variable frequency drive
Drive belt	Poly-groove drive belt with easy access	Poly-groove drive belt with easy access
Spindle	1.25" x 8 tpi right hand thread	1.25" x 8 tpi right hand thread
Spindle taper	MT 2	MT 2
Spindle lock	Spring loaded	Spring loaded
Spindle index	14 / 36 / 48 positions with lock	14 / 36 / 48 positions with lock

Headstock & tailstock bore	0.375" dia (9.5mm dia)	0.375" dia (9.5mm dia)
Tail stock travel	4.5" (114mm)	4.5" (114mm)
Tail stock removal	Self- ejecting	Self- ejecting
Tailstock tapers	MT 2	MT 2
Face plate	3" diameter (76mm)	3" diameter (76mm)
Bed material	Steel	Steel
Weight (Net / ship)	427/452 lbs (194kg / 206 kg)	425/450 lbs(193/205 kg)

Receiving your machine.

Note. It is probable that your machine will be delivered by a third party. Before you unpack your new machine you will need to first inspect the packing, invoice and shipping documents supplied by the driver.

Insure that there is no visible damage to the packing or the machine. You need to do this prior to the driver leaving. All damage must be noted on the delivery documents and signed by you and the delivery driver. You must then contact the seller (Laguna Tools) as soon as practical. If damage is found after delivery, contact the seller as soon as is practical.

Note. It is probable that you will find sawdust within your machine. This is because the machine has been tested prior to shipment from the factory and or Laguna Tools. Laguna Tools endeavours to test machines prior to shipping to customers as movement can take place during transportation. It must be noted that additional machine movement can take place between Laguna Tools and the end user and some adjustments may have to be undertaken by the customer. These adjustments are covered in the various sections of this manual.

Introduction to lathes.

This machine is designed to give you years of safe service. Read this owner's manual in its entirety before assembly or use.

Parts of the lathe.

The lathe consists of a number of major parts, which are discussed in this manual. Take the time to read this section and become familiar with the machine.

Identification.

There is a plate at the back of the machine listing all the manufacturing data, including the serial number, model, etc.

LAGUNA 	
Laguna REVO 18 36 Lathe	
Model	MLAREVO 1836
Motor	2 HP, 230V
Power Requirements	230V, 1Ph
Serial No.	111111111
Taiwan TCP	

LAGUNA 	
Laguna REVO 18 36 Lathe	
Model	MLAREVO 1836-110-150
Power Requirements	115V, 1Ph
Serial No.	
Taiwan TCP	

Lathe Bed.

The bed is a machined heavy steel welded construction.

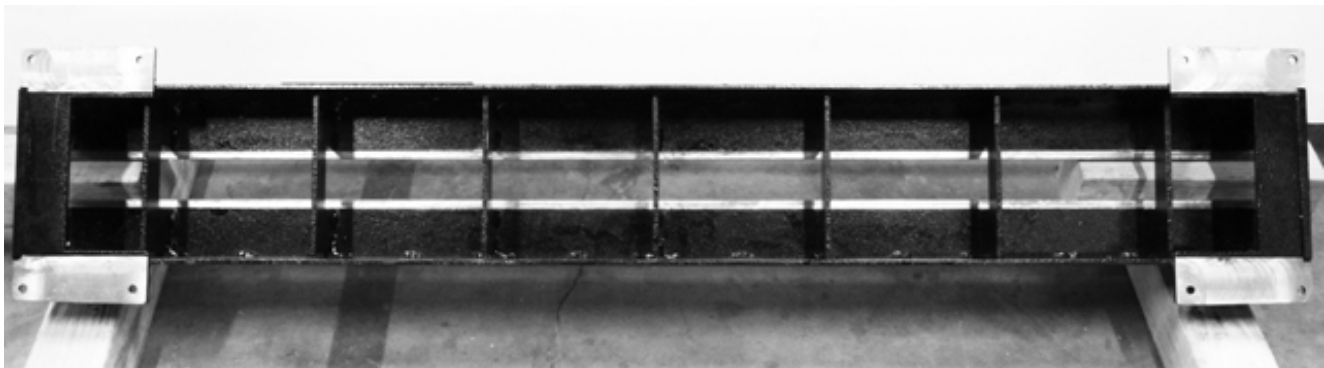

Underside of lathe bed

Lathe legs.

The Legs are cast iron, and their heavy construction gives the machine a low center of gravity and ensures that it is very stable. The legs are supplied with adjustable feet to allow the machine to be leveled.



Legs with adjustable feet assembled

Head stock.

The head stock is cast iron and houses the variable speed control and motor. The Spindle can be locked in 14 / 36 and 48 positions.



Headstock removed from the bed



Headstock attached to bed

Tail stock.

The tail stock is of cast iron construction, and the spindle has a travel of 4 1/2 in. It can accommodate centers and other tools which have a number 2 Morse Taper. The tail stock can be moved to any position on the lathe bed and locked to suit the job at hand.



Tailstock viewed from the back



Tailstock viewed from the front

Tool rest.

The tool rest can be moved to any position on the lathe bed and locked to suit the job at hand. The tool rest has a tall profile to allow the bowl turner to turn steep angles. The leading edge is made from 6mm hardened steel.



Tool rest assembled to the bed



Tool rest

Electrical system.

220V: The electrical control system (VFD) is housed at the back of the head stock, The VFD converts single phase 220v to three phase. There is a speed readout at the front of the lathe with controls to fine adjust the RPM of the spindle. . A power cord with 220V plug is provided.

110V: The electrical control system (VFD) is housed at the back of the head stock, The VFD converts single phase 110v to three phase. There is a speed readout at the front of the lathe with controls to fine adjust the RPM of the spindle. A power cord with 110V plug is provided.



VFD with cover open

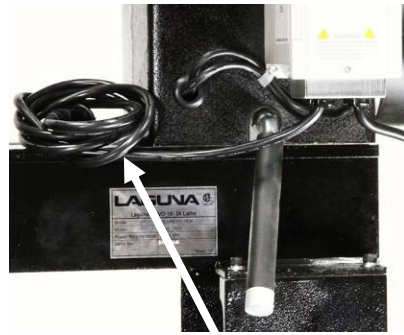

Power cord

Tool storage.

A tool storage bracket which can be mounted on either leg.



Tool storage bracket

What you will receive with the lathe.

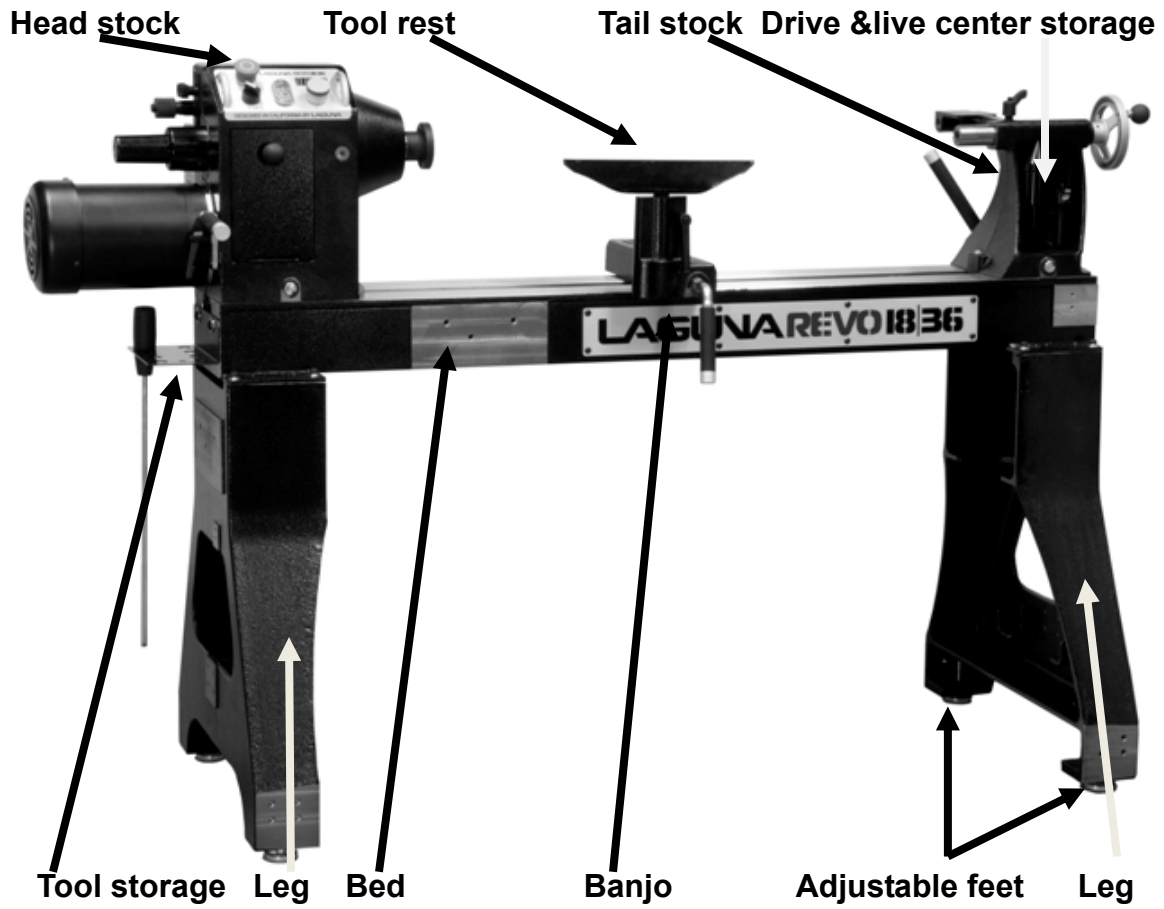

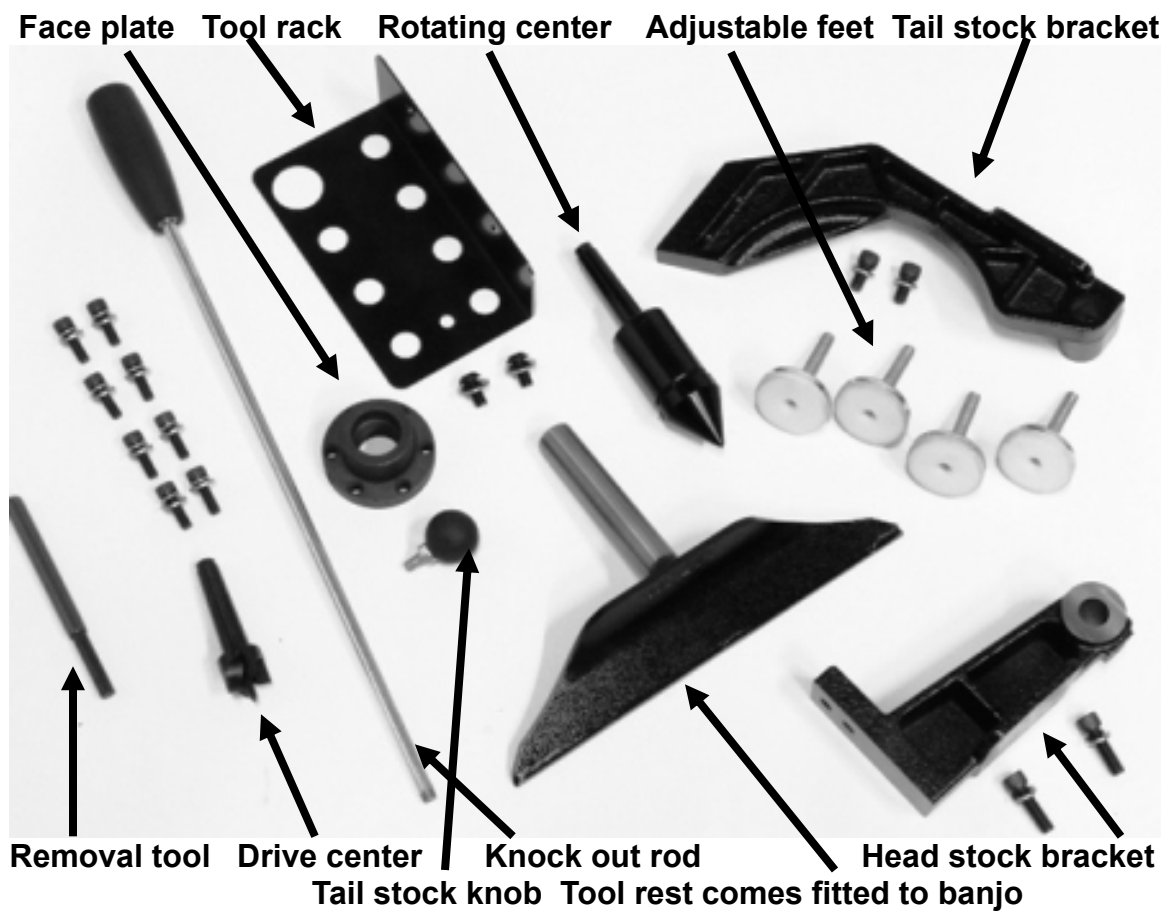

Where to locate your machine.

Before you remove your machine from the packaging, select the area where you will use your machine. There are no hard and fast rules for its location, but below are a few guidelines:

1. There should be sufficient area at the front of the machine to allow you to work on it comfortably.
2. There should be sufficient area at the back of the machine to allow access for adjustments and maintenance to be conducted.
3. Adequate lighting. The better the lighting the more accurately and safely you will be able to work.
4. Solid floor. You should select a solid flat floor, preferably one made of concrete or something similar.
5. Locate it close to a power source and dust collection.
6. Allow an area for the storage of blanks, finished products and tools.

Unpacking your machine.

To unpack your machine you will need tin snips, a knife, and a wrench.

1. Using the tin snips, cut the banding that is securing the packing box (if fitted). **WARNING: EXTREME CAUTION MUST BE USED, BECAUSE THE BANDING WILL SPRING AND COULD CAUSE INJURY.**



Lathe in packaging

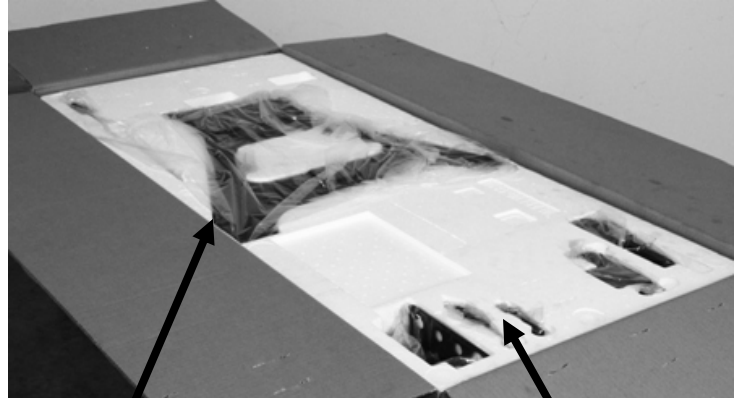

Leg

Parts of the lathe

Second leg



Top packaging removed

2. Open the box and remove the parts sent with the lathe including the first leg.

Note. The legs are heavy and caution must be exercised. They are cast iron and if dropped they will break.

3. Remove the top packaging and remove the second leg.

4. Remove the lathe bed. It is recommended that it be lifted with a hoist or forklift using a "sling". as it is very heavy.

Note. The machine is heavy. Ensure that you have enough people to do the job safely.

Note. If you have any doubt about the described procedure, seek professional assistance. Do not attempt any procedure that you feel is unsafe, or that you do not have the physical capability of achieving.



5. Lower the bed of the lathe onto 2 stacks of wood. This will allow access to the underside of the bed.

Assembly and setup.

The machine comes mostly assembled. You will have to assemble the legs, headstock, tailstock, tool storage and the tool rest to the bed of the machine.

Note. It is recommended that the head stock, tool rest and tailstock be removed from the bed of the lathe to ease assembly (Covered later in the manual).

Assembling the legs to the bed of the lathe.

There is a stop at both ends of the bed. The stop is a safety feature that makes it impossible for the headstock or tailstock to slide off the end of the bed.

Remove the stops and loosen the clamps on both the head stock, tool rest and tailstock. Slide them off the bed. This will greatly reduce the weight of the bed and allow easier assembly.

Note : The headstock and tailstock are very heavy and extreme caution must be exercised when removing them from the bed of the lathe. Take care not to cause damage during removal.

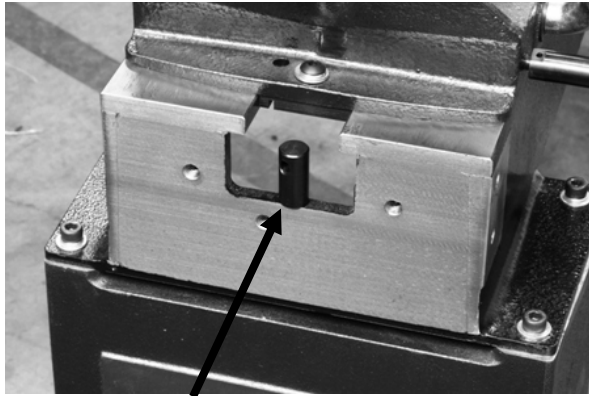

Stop



Tailstock clamp handle

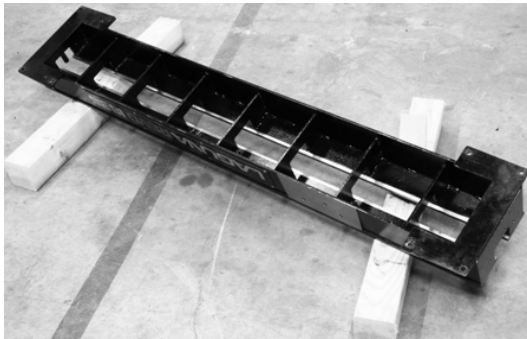

Bed with headstock and tailstock removed

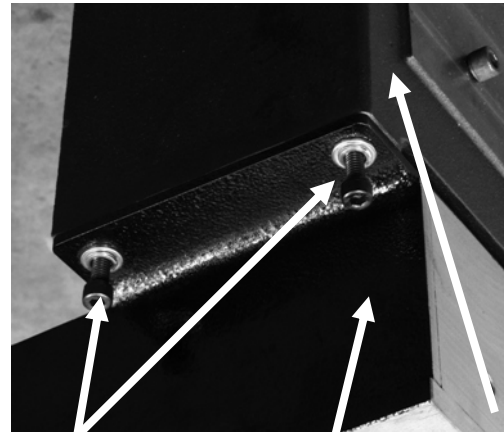

Leg fixing screws

Bed

Leg

Lay the bed on 2" X 4" timbers in the upside down position. Lift the legs to the vertical position and lower them onto the bed. Secure with the fixing screws provided.

Note. At least two people will be needed to perform the assembly, one to hold the leg in position and one to fit the fixing screws.

Note. If you have any doubt about the described procedure, seek professional assistance. Do not attempt any procedure that you feel is unsafe, or that you do not have the physical capability of achieving. Fit the 4 leveling feet to the lathe legs with the lock nut on the underside of the leg. Once both legs have been fitted turn the assembly up to the correct position.

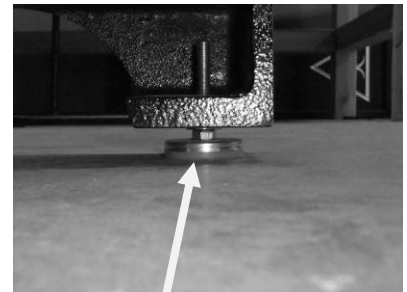

Leveling foot



Assemble the head stock, tool rest and tailstock back onto the bed of the lathe and **fit the stops.**

Note. If you have any doubt about the described procedure, seek professional assistance. Do not attempt any procedure that you feel is unsafe, or that you do not have the physical capability of achieving.



Assembled lathe

If you decide to fit the tool rest after fitting the tail stock, follow the below procedure.
Fit the tool rest onto the bed of the lathe ensuring that the washer recess fits into the slot in the bed.
Fit the banjo onto the bed with the bolt through the washer and assemble the nut onto the thread.
Adjust the nut so that the clamp handle locks the banjo with approximately 30 degree of movement.



Tool rest unassembled



Washer

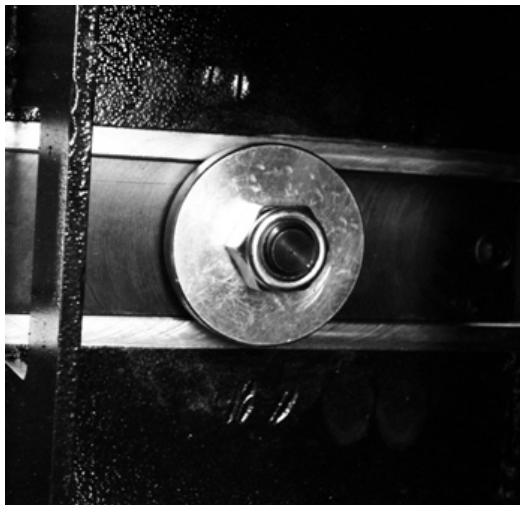

Washer assembled in position



Banjo clamp handle

Fitting the stock knob.

Screw the tail stock knob onto the tail stock handle.



Tail stock knob



Tail stock handle

Connecting the electrical supply.

Ensure that the electrical supply corresponds with that of the machine (Single phase 220V or 110V).

It is recommended that you use a 15-amp main breaker.

Note. A qualified electrician must carry out the installation.



Electrical cable

Cleaning the machine.

Remove the rust protection grease with WD 40 or a similar solvent.

It is important that you remove all the grease and re-lubricate with a Teflon-based lubricant. (Teflon has a lower tendency to attract sawdust and cause clogging).

Fitting the rotating center.

Ensure that the bore of the tail stock is clean. The rotating center has a number 2 Morse Taper that fits into the tail stock.

Push the center into the tail stock bore firmly, and ensure that it is securely located. To remove the center, rotate the adjusting handle until it is as far back as possible and this will eject the center.

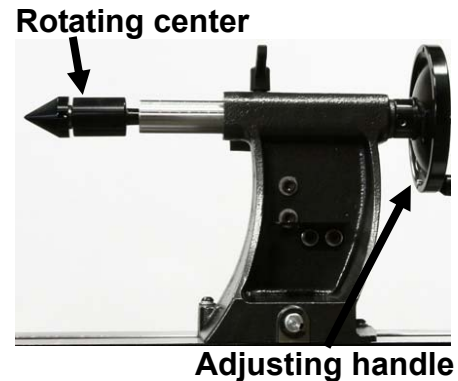

Fitting the drive center into the head stock.

To remove the face plate from the head stock spindle, insert the removal tool into the hole in the face plate large diameter. Lock the spindle with the lathe spindle lock and unlock the face plate by rotating it. Take care not to drop the faceplate onto the bed of the lathe.

Note. The face plate has a left-hand thread.



Removal tool

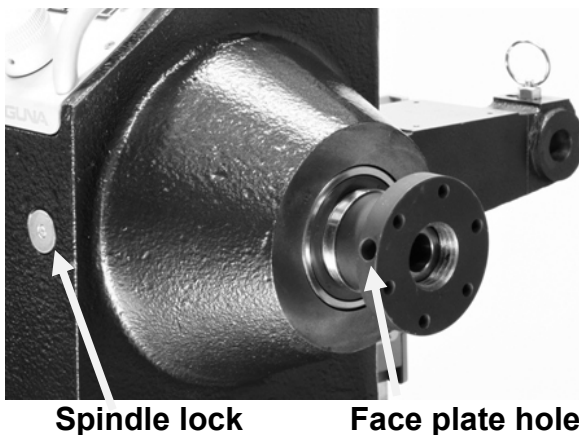

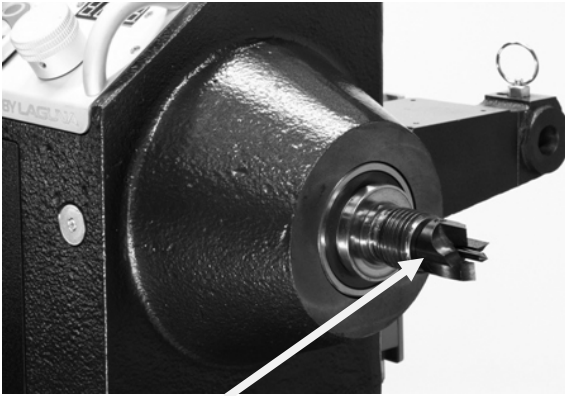

Headstock drive center

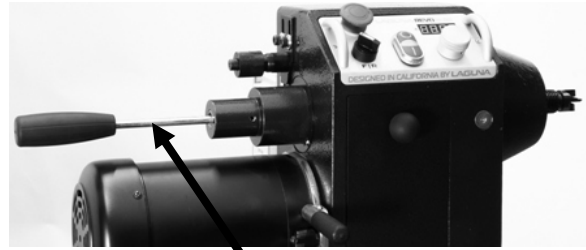

Drive center removal shaft

Ensure that the bore of the head stock is clean. The drive center has a number No. 2 Morse Taper that fits into the head stock

Push the center into the head stock bore firmly, and ensure that it is securely located. To remove the center, push the removal shaft into the back of the head stock, and give it a sharp knock. This will remove the drive center.

Note. Never leave the removal shaft in the head stock with the machine running.

Fitting the face plate.

Reverse the removal procedure, described earlier.

Lathe controls.

Emergency stop button

The emergency stop button will lock in the OFF position when fully depressed. To reset it, twist clockwise and it will pop out.

Forward / reverse switch.

The forward / reverse switch selects the direction of the rotation of the spindle.

The forward / reverse switch must only be used once the spindle has come to a complete stop.

Start / Stop buttons.

The start / stop buttons start the motor and the rotation of the spindle.

Speed display.

The speed display shows the RPM of the spindle.

Variable speed adjustment knob.

The Variable speed adjustment knob adjusts the spindle speed.

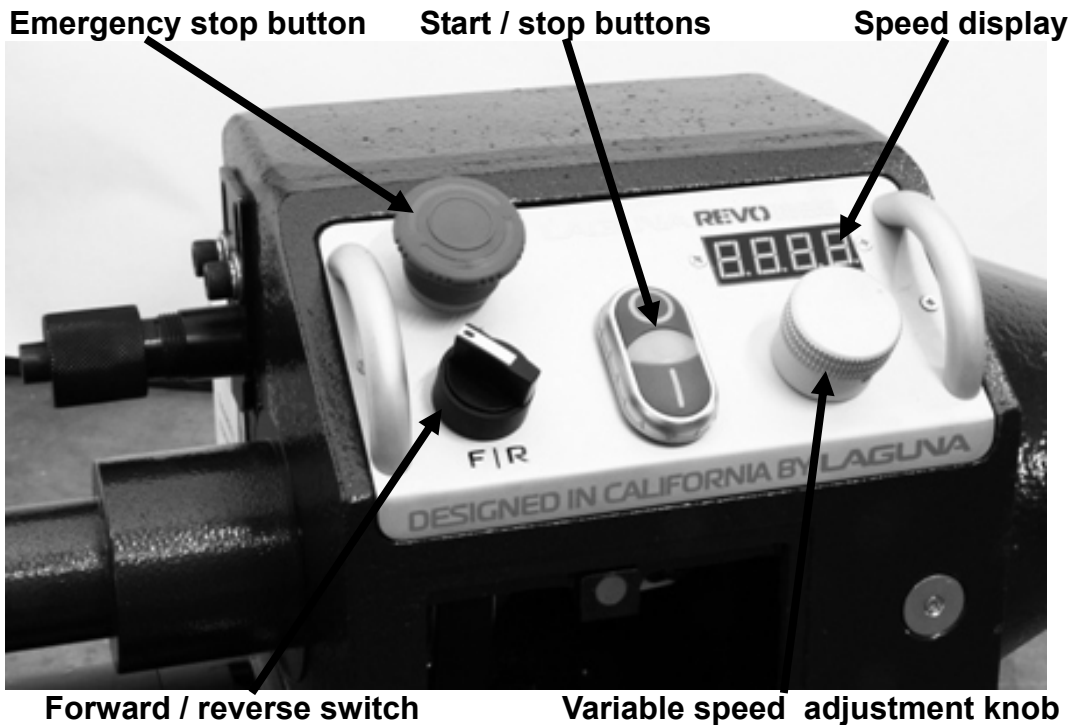

Head stock clamp lever

Head stock clamp lever.

The head stock clamp lever allows the head stock to be released and moved to any position on the lathe bed. It is located at the back of the head stock.

Variable speed adjustment knob.



The Variable speed adjustment knob adjusts the spindle speed. Turns clockwise to increase the speed, turns counter-clockwise to decrease the speed

High / low speed.

The lathe has two sets of pulleys for high (135 - 3500 RPM) and low (50 - 1300 RPM) speed ranges.

Adjust between the speed ranges as follows.

1. Disconnect the electric supply to the lathe.
2. Open the pulley cover.
3. Loosen the motor lock handle and lift the motor to the highest position with the motor adjustment handle, then lock the motor lock handle.
4. Move the drive belt to the required set of pulleys.
5. Loosen the motor lock handle and with the motor adjustment handle tension the drive belt, then lock the motor lock handle.

The belt should be tensioned so that there is approximately 1/8 to 1/4 " deflection when the belt is pressed with moderate thump pressure.

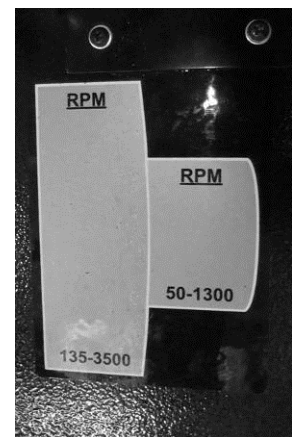

Speed range

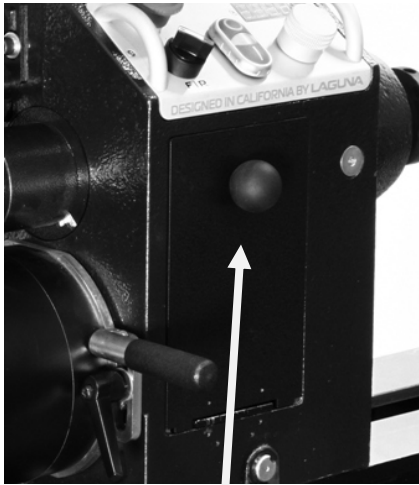

Pulley cover

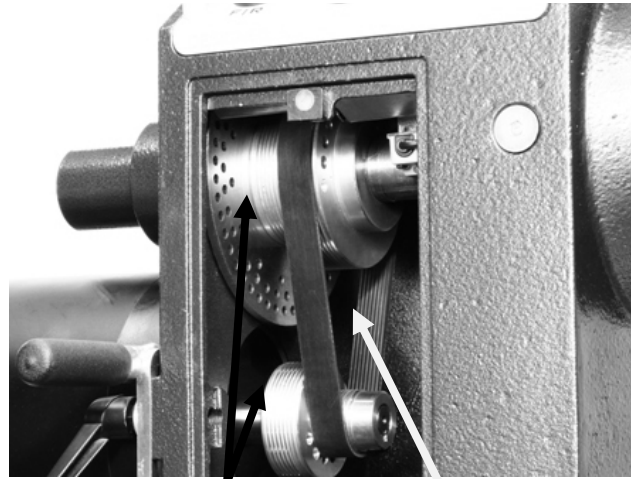

Pulleys and drive belt

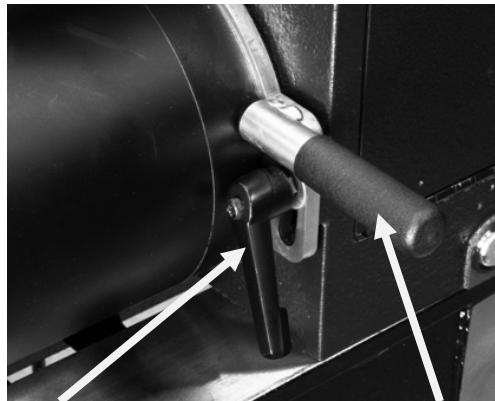

Motor lock handle Motor adjustment handle

Indexing the spindle.

The spindle has 3 sets of indexing holes 14 / 36 / 48. The selection plunger is located at the end of the head stock. To move between the 3 sets of holes, loosen the clamp knobs and slide the indexing plunger assembly to align with the selected hole set. Clamp in position with the clamp knobs. Try the plunger in a few different holes to check that it inserts and removes smoothly.

The indexing plunger is spring loaded and this is used only to temporarily align the plunger in the selected hole.

To fix the plunger in a selected hole, it must be attached to the housing by screwing into the clamped position.

There is a hole selection indicator that allows you to view which hole in a selected hole set has been selected.

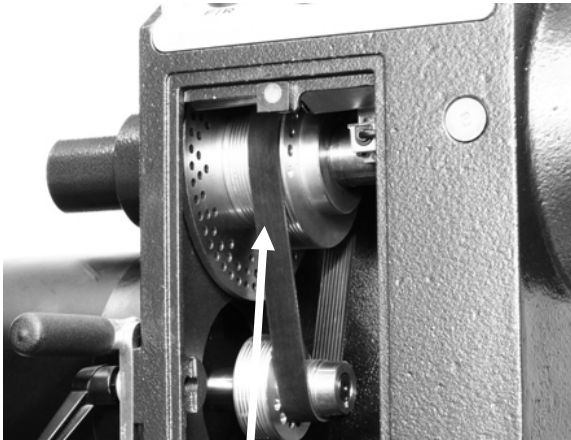

Indexing holes

Clamping knobs
Hole selection indicator

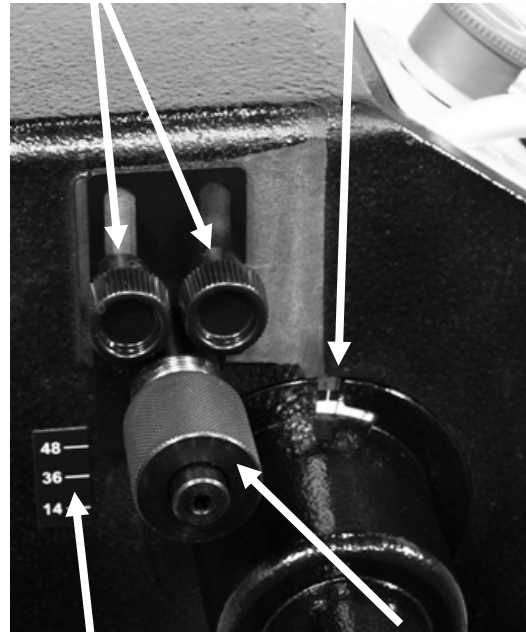

Hole selection

Indexing plunger

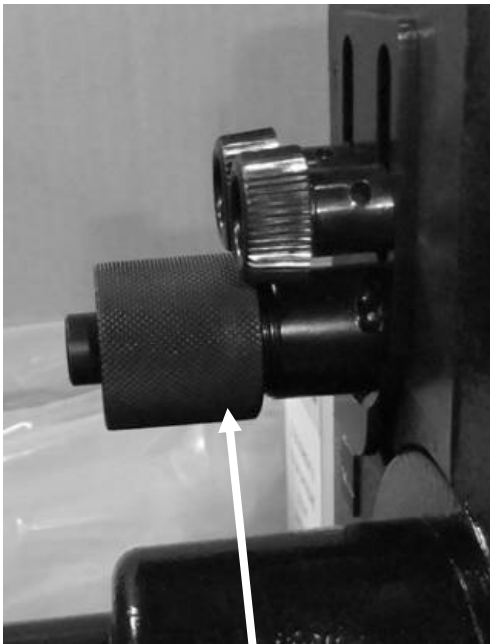

Indexing plunger engaged

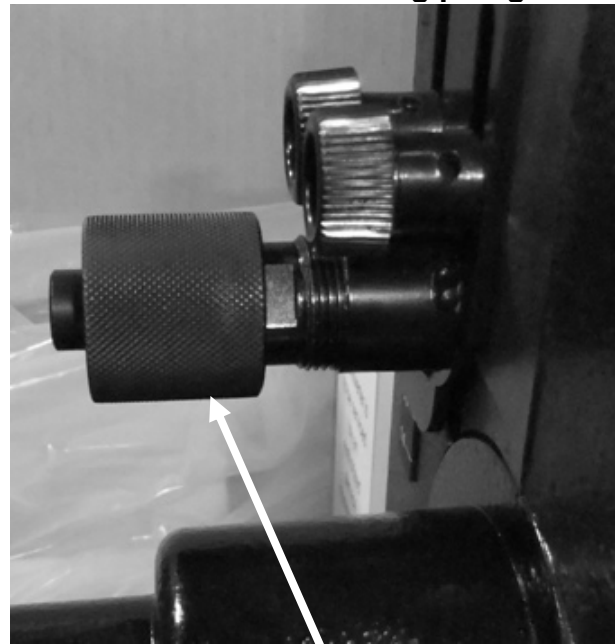

Indexing plunger disengaged

Maintenance.

General.

Keep your machine clean. At the end of each day, clean the machine. Wood contains moisture, and if sawdust or wood chips are not removed they will cause rust. In general, we recommend that you only use a Teflon-based lubricant on the lathe. Regular oil attracts dust and dirt. Teflon lubricant tends to dry and has less of a tendency to accumulate dirt and saw dust.

Periodically check that all nuts and bolts are tight.

Drive belt.

The drive belt should last for many years (depending on the usage) but needs to be inspected regularly for cracks, cuts and general wear. If damage is found, replace the belt.

Bearings.

All bearings are sealed for life and do not require any maintenance. If a bearing becomes faulty, replace it.

Rust.

The lathe is made from steel and cast iron. All none-painted surfaces will rust if not protected. It is recommended that they be protected by applying wax or a Teflon-based lubricant to them.

Center point alignment and slide clearance adjustment.

The center point alignment and slide clearance are adjusted at the factory and no adjustment should be required. Should movement or wear have taken place, the following adjustment procedure should be conducted.

Note. The slide clearance of the headstock and the tailstock must be checked and adjusted should it be needed prior to adjusting the center point alignment.



Center points aligned

Slide adjustment.

Loosen the clamp handle on the tailstock and check for side movement. If it is excessive, insert an Allen key into the adjusting screw and tighten.

Note. By rotating the adjustment screw, it moves into the adjusting slot which opens and removes the excessive clearance between the tailstock and the bed.

Note . Only make very small adjustments and then recheck the clearance. After adjustment

the tailstock should be slid along the bed to check for any area that it binds in the bed slot.

The same procedure as above should be conducted on the head stock should it be required.

Note. It is very unlikely that the headstock will require adjustment as it is not moved as often as the tailstock, so has less tendency's for ware.

Adjustment slot



View under the tailstock

Adjustment slot



View under headstock

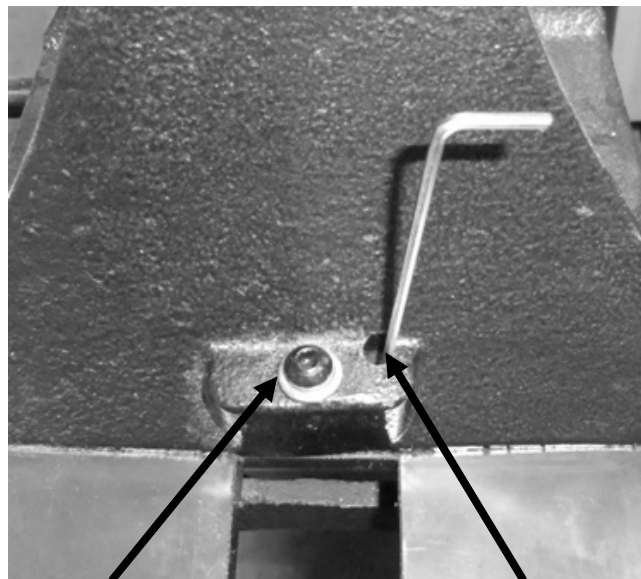

Clamp screw

Adjusting screw

Center point alignment.

The tailstock has two clamp screws that are accessible from the top of the tailstock. The clamp screws hold the slide plate to the tailstock casting. There is clearance in the holes that allows the tailstock to be moved in relation to the slide plate. The headstock also has two clamp screws, but one is accessible from under the headstock.

By loosening the clamp screws the headstock and tailstock can be moved and the center points aligned.

Note. It is recommended that the head stock be adjusted and not the tail stock. If the tail stock is not adjusted parallel to the bed slide, the center point will not be in alignment when the spindle is extended or retracted.

1. Loosen the clamp screw that is accessible from the top on the head stock.
2. Tap the side of the headstock with a rubber mallet close to the base in the direction requiring adjustment and retighten the clamp screw.
3. Recheck the center point alignment and repeat if required.

Note. Never hit any part of the lathe that is cast iron with a metal hammer or similar as it **will** break the casting.

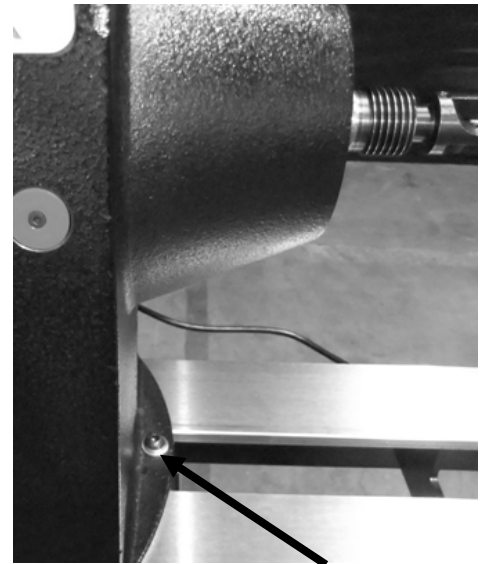

Headstock clamp screw

Troubleshooting.

Lathe will not start.

1. Check that the start switch is in the correct position.
2. Check that the electrical power cord is plugged into the power outlet.
3. Check that the electrical supply is on (reset the breaker).
4. With the power disconnected from the machine, check that the wiring to the plug is correct. Check that the rubber insulation is stripped enough and is not causing a bad connection. Check that all the screws are tight.
5. Emergency stop button engaged. Reset emergency stop button. Twist and it will pop out.

The machine will not stop.

This is a very rare occurrence as the machine is designed to be fail-safe. If it should occur and you cannot fix the fault, seek professional assistance. The machine must be disconnected from the power and never run until the fault has been rectified.

1. The stop switch is faulty. Replace the stop switch.

Motor tries to start but will not turn.

1. With the power disconnected from the machine, try to turn the spindle by hand. If the spindle will not turn, check the reason for jamming.
2. Capacitor faulty. Replace the capacitor.
3. Motor faulty. Replace the motor.
4. Power line overloaded. Correct overloaded condition.
5. Low voltage. Correct low voltage condition.

Motor overheats.

The motor is designed to run hot, but should it overheat it has an internal thermal overload protector that will shut it down until the motor has cooled, and then it will reset automatically. If the motor overheats, wait until it has cooled and restart. If the motor shuts down consistently check for the reason. Typical reasons are dull cutting tools, the motor cooling fan being clogged or faulty, the motor cooling fins are clogged, overfeeding the job, and excessive ambient temperature.

Squeaking noise.

1. Check that the motor cooling fan is not contacting the fan cover.
2. Check the bearings.
3. Check the drive belt is tensioned correctly.

Spindle slows down during a cut.

1. Dull cutting tools. Replace the tool or have it re-sharpened.
2. Feeding the wood too fast. Slow down the feed rate.
3. Oil or dirt on the drive belt. Clean or replace the drive belt.
4. Drive belt loose. Re-tension drive belt.

Machine vibrates.

1. Machine not level on the floor. Re-level the machine ensuring that it has no movement.
2. Damaged drive belt. Replace the belt.
3. Job is not balanced. Change to slower speed and/ or balance the job.
4. Damaged pulley. Replace the pulley.
5. Worn spindle bearing. Replace the bearing.

Electrical drawing.

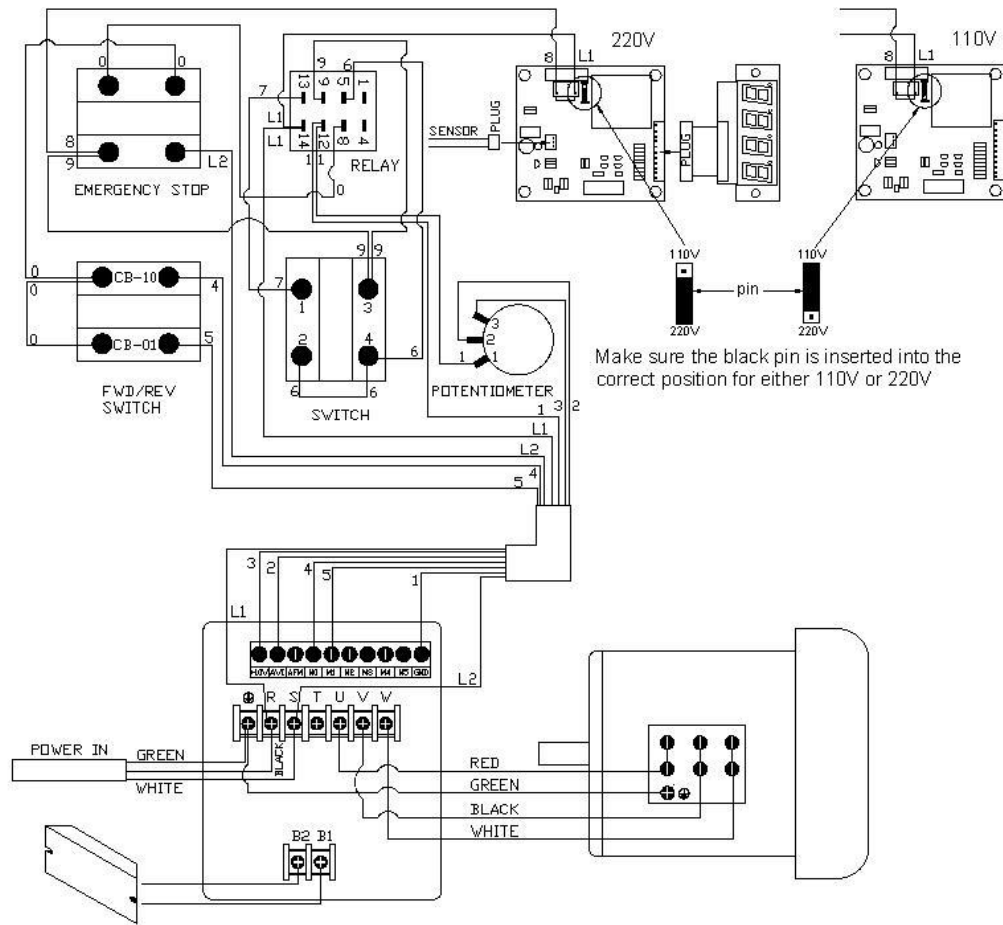

Exploded view drawings and parts list.

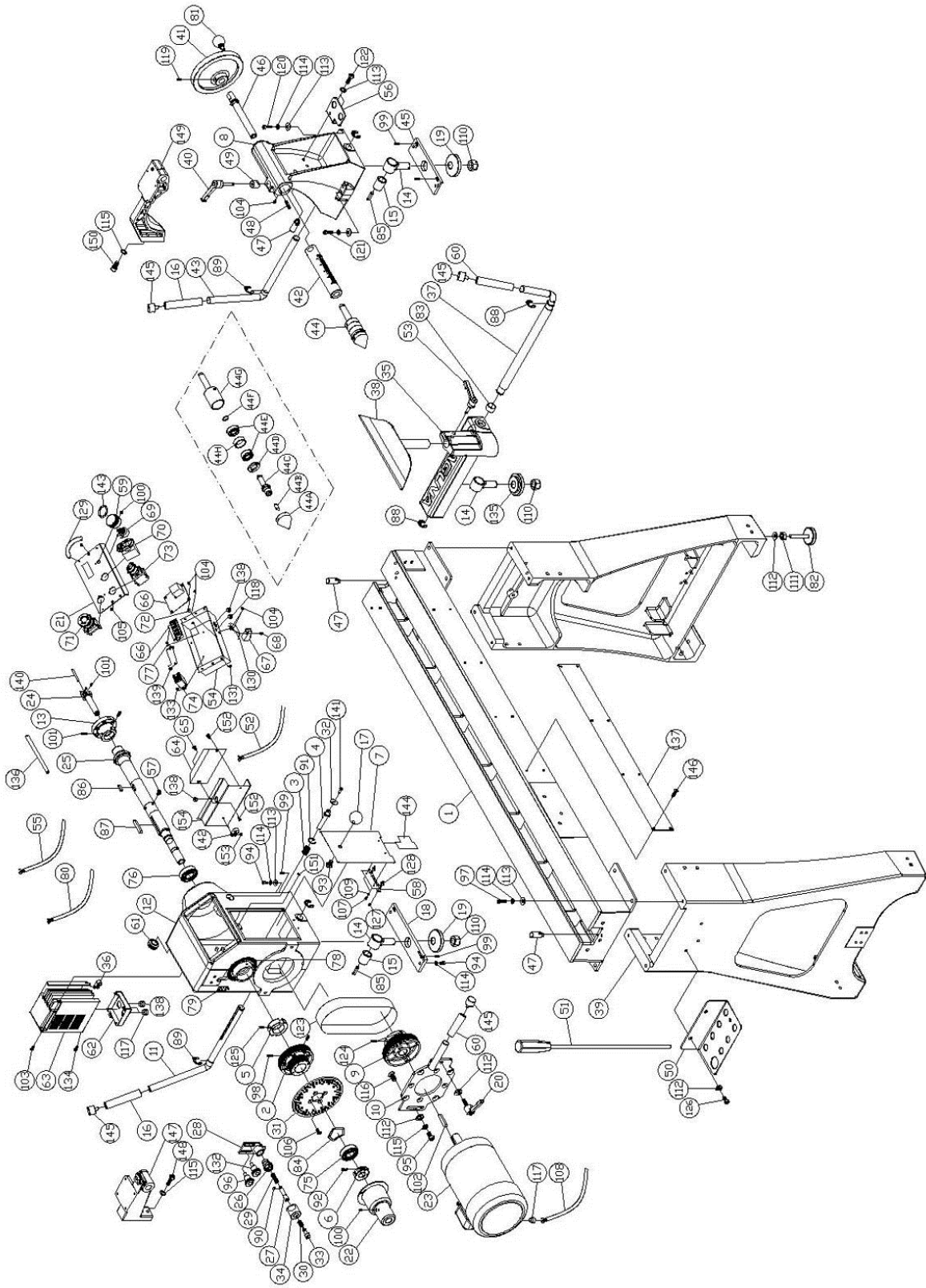

REVO 18 36 LATHE				
Index	Part Number	Item Description	Specification	Qty
1	PLAREVO1836-101	Bed		1
2	PLAREVO1836-102	Spindle Pulley		1
3	PLAREVO1836-103	Spring		1
4	PLAREVO1836-104	Spindle Lock Plunger		1
5	PLAREVO1836-105	Locking Collar		1
6	PLAREVO1836-106	Bearing Nut		1
7	PLAREVO1836-107	Door		1
8	PLAREVO1836-108	Tailstock		1
9	PLAREVO1836-109	Motor Pulley		1
10	PLAREVO1836-110	Motor Plate		1
11	PLAREVO1836-111	Headstock Locking Handle		1
12	PLAREVO1836-112	Headstock		1
13	PLAREVO1836-113	3" Faceplate		1
14	PLAREVO1836-114	Clamp Bolt		3
15	PLAREVO1836-115	Sleeve		2
16	PLAREVO1836-116	Rubber Sleeve		2
17	PLAREVO1836-117	Knob		1
18	PLAREVO1836-118	Headstock Adjusting Plate		1
19	PLAREVO1836-119	Clamp		2
20	PLAREVO1836-120	Lock Handle		1
21	PLAREVO1836-121	Control Panel		1
22	PLAREVO1836-122	Handwheel		1
23	PLAREVO1836-123	Motor 2HP		1
	PLAREVO1836-110-150-123	Motor 1.5HP		1
24	PLAREVO1836-124	Spur Center		1
25	PLAREVO1836-125	Spindle		1
26	PLAREVO1836-126	Index Stud		1
27	PLAREVO1836-127	Index Shaft		1
28	PLAREVO1836-128	Index Bracket		1
29	PLAREVO1836-129	Spring		1
30	PLAREVO1836-130	Spring		1
31	PLAREVO1836-131	Index Plate		1
32	PLAREVO1836-132	Disc, Spindle Lock		1
33	PLAREVO1836-133	Index Bolt		1
34	PLAREVO1836-134	Index Knob		1

35	PLAREVO1836-135	Tool Rest Support Base		1
36	PLAREVO1836-136	Cord Holder		1
37	PLAREVO1836-137	Tool Rest Locking Handle		1
38	PLAREVO1836-138	12" Tool Rest		1
39	PLAREVO1836-139	Leg		2
40	PLAREVO1836-140	Lock Handle		1
41	PLAREVO1836-141	Handwheel		1
42	PLAREVO1836-142	Quill		1
43	PLAREVO1836-143	Tailstock Locking Handle		1
44	PLAREVO1836-144	Live Center Assembly		1
45	PLAREVO1836-145	Tailstock Adjusting Plate		1
46	PLAREVO1836-146	Lead Screw		1
47	PLAREVO1836-147	Stop Bolt		3
48	PLAREVO1836-148	Key		1
49	PLAREVO1836-149	Quill Lock Sleeve		1
50	PLAREVO1836-150	Tool Caddy		1
51	PLAREVO1836-151	Knockout Rod		1
52	PLAREVO1836-152	Braking Resistor Cord		1
53	PLAREVO1836-153	Lock Handle		1
54	PLAREVO1836-154	Control Box		1
55	PLAREVO1836-155	Control Cord		1
56	PLAREVO1836-156	Tailstock Tool Caddy		1
57	PLAREVO1836-157	Hex Cap Screw	M6x6	4
58	PLAREVO1836-158	Door Hinge		1
59	PLAREVO1836-159	Speed Knob		1
60	PLAREVO1836-160	Rubber Sleeve		2
61	PLAREVO1836-161	Rubber Bushing		1
62	PLAREVO1836-162	Bottom Cover		1
63	PLAREVO1836-163	Inverter 220V		1
	PLAREVO1836-110-150-163	Inverter 110V		1
64	PLAREVO1836-164	Braking Resistor		1
65	PLAREVO1836-165	Screw	M4x12	1
66	PLAREVO1836-166	Digital Readout		1
67	PLAREVO1836-167	Digital Readout Sensor		1
68	PLAREVO1836-168	Screw	M3x20	2
69	PLAREVO1836-169	Control Pot Assembly		1
70	PLAREVO1836-170	ON/ OFF Switch		1

71	PLAREVO1836-171	Emergency Stop		1
72	PLAREVO1836-172	Spacer		2
73	PLAREVO1836-173	Fwd/Rev Switch		1
74	PLAREVO1836-174	Relay 220V		1
	PLAREVO1836-110-150-174	Relay 110V		1
75	PLAREVO1836-175	Ball Bearing	6205LLU	1
76	PLAREVO1836-176	Ball Bearing	6207LLU	1
77	PLAREVO1836-177	Pillar		2
78	PLAREVO1836-178	Index Label		1
79	PLAREVO1836-179	Index Indicator		1
80	PLAREVO1836-180	Power Cord 220V		1
	PLAREVO1836-110-150-180	Power Cord 110V		1
81	PLAREVO1836-181	Knob		1
82	PLAREVO1836-182	Leveling Foot		4
83	PLAREVO1836-183	Bushing		1
84	PLAREVO1836-184	Wave Washer	6205	1
85	PLAREVO1836-185	Key	6x6x30	2
86	PLAREVO1836-186	Key	8x7x25	1
87	PLAREVO1836-187	Key	8x7x60	1
88	PLAREVO1836-188	E-Ring	E19	2
89	PLAREVO1836-189	E-Ring	E15	4
90	PLAREVO1836-190	E-Ring	E5	1
91	PLAREVO1836-191	C-Ring	R22	1
92	PLAREVO1836-192	Socket Head Cap Screw	1/4-20UNCx1"	1
93	PLAREVO1836-193	Hex Cap Screw	3/8-16UNCx1/2"	1
94	PLAREVO1836-194	Socket Head Button Screw	M8x20	2
95	PLAREVO1836-195	Socket Head Cap Screw	3/8-16UNCx1"	1
96	PLAREVO1836-196	Knob		1
97	PLAREVO1836-197	Socket Head Cap Screw	5/16-18UNCx1"	8
98	PLAREVO1836-198	Set Screw	5/16-18UNCx3/8	2
99	PLAREVO1836-199	Set Screw	M8x6	4
100	PLAREVO1836-1100	Set Screw	M4x4	2
101	PLAREVO1836-1101	Set Screw	1/4-20UNCx1/4	3
102	PLAREVO1836-1102	Key	5x5x50	1
103	PLAREVO1836-1103	Screw	M4x15	2
104	PLAREVO1836-1104	Screw	M3x8	8
105	PLAREVO1836-1105	Phillips Flat Head Screw	M3x8	2

106	PLAREVO1836-1106	Phillips Flat Head Screw	M6x16	4
107	PLAREVO1836-1107	Screw	M3x4	2
108	PLAREVO1836-1108	Motor Cord		1
109	PLAREVO1836-1109	Flat Washer	D3xD8x1t	2
110	PLAREVO1836-1110	Nylon Insert Lock Nut	M18x2.5	3
111	PLAREVO1836-1111	Hex Nut	3/8-16UNC	4
112	PLAREVO1836-1112	Flat Washer	D10xD23x2t	7
113	PLAREVO1836-1113	Flat Washer	D8xD18x2t	14
114	PLAREVO1836-1114	Lock Washer	5/16"	12
115	PLAREVO1836-1115	Lock Washer	3/8"	5
116	PLAREVO1836-1116	Phillips Flat Head Screw	3/8-16UNCx3/4"	4
117	PLAREVO1836-1117	Strain Relief	7N-2	3
118	PLAREVO1836-1118	Strain Relief	SB2F-1	1
119	PLAREVO1836-1119	Set Screw	1/4-20UNCx3/8	1
120	PLAREVO1836-1120	Socket Head Button Screw	M8x25	1
121	PLAREVO1836-1121	Socket Head Button Screw	M8x45	1
122	PLAREVO1836-1122	Socket Head Cap Screw	5/16-18UNCx1/2"	3
123	PLAREVO1836-1123	Poly-V Belt	PJ8-190	1
124	PLAREVO1836-1124	Set Screw	3/16-24UNCx3/16	2
125	PLAREVO1836-1125	Set Screw	5/16-18UNCx1/4	1
126	PLAREVO1836-1126	Socket Head Button Screw	3/8-16UNCx5/8"	2
127	PLAREVO1836-1127	Screw	M3x12	2
128	PLAREVO1836-1128	Spacer		2
129	PLAREVO1836-1129	Handle		2
130	PLAREVO1836-1130	Sensor Bracket		1
131	PLAREVO1836-1131	Phillips Flat Head Screw	M3x4	4
132	PLAREVO1836-1132	Knob		1
133	PLAREVO1836-1133	Screw	M3x4	1
134	PLAREVO1836-1134	Screw	M3x10mm	3
135	PLAREVO1836-1135	Clamp		1
136	PLAREVO1836-1136	Handle, Faceplate		1
137	PLAREVO1836-1137	Logo Plate		1
138	PLAREVO1836-1138	Strain Relief	6N-4	4
139	PLAREVO1836-1139	Bracket		1
140	PLAREVO1836-1140	Thimble		1
141	PLAREVO1836-1141	Socket Flat Head Screw	M3x8	1
142	PLAREVO1836-1142	Cord Holder		1

143	PLAREVO1836-1143	O-Ring	P29	1
144	PLAREVO1836-1144	Speed Label		1
145	PLAREVO1836-1145	Cap		4
146	PLAREVO1836-1146	Socket Head Button Screw	1/4-20UNCx3/8"	8
147	PLAREVO1836-1147	Headstock Bracket		1
148	PLAREVO1836-1148	Socket Head Cap Screw	3/8-16UNCx1-1/4"	2
149	PLAREVO1836-1149	Tailstock Bracket		1
150	PLAREVO1836-1150	Socket Head Cap Screw	3/8-16UNCx3/4"	2
151	PLAREVO1836-1151	Magnet		1
152	PLAREVO1836-1152	Screw	M4x6	2
153	PLAREVO1836-1153	Hex Nut	M4x0.7	1
154	PLAREVO1836-1154	Braking Resistor Cover		1

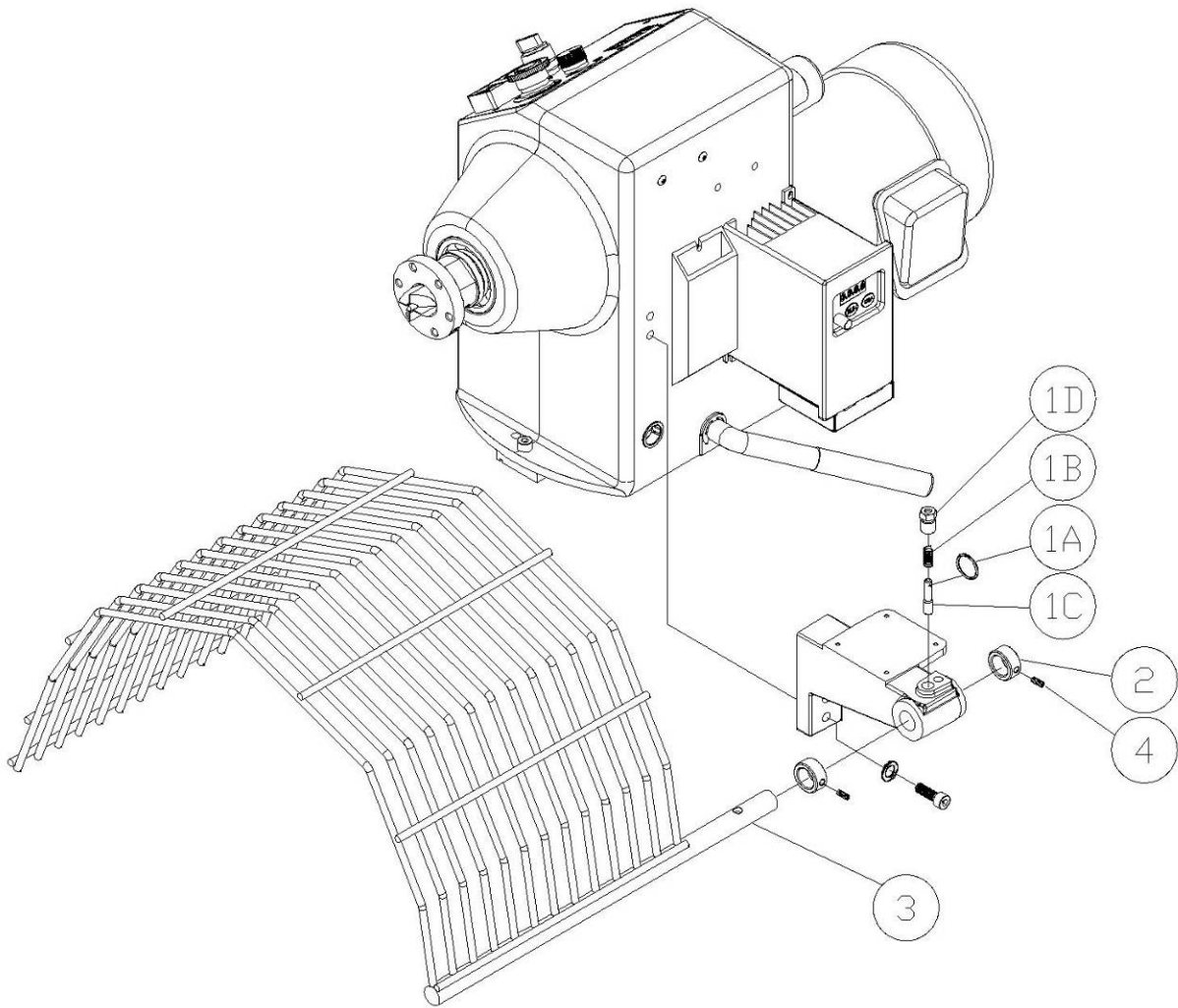

Optional Headstock Guard				
Index	Part Number	Item Description	Specification	Qty
1	PLAREVO1836-201	Plunger		1
2	PLAREVO1836-202	Retaining Collar		2
3	PLAREVO1836-203	Guard		1
4	PLAREVO1836-204	Set Screw	1/4-20UNCx1/4"	2

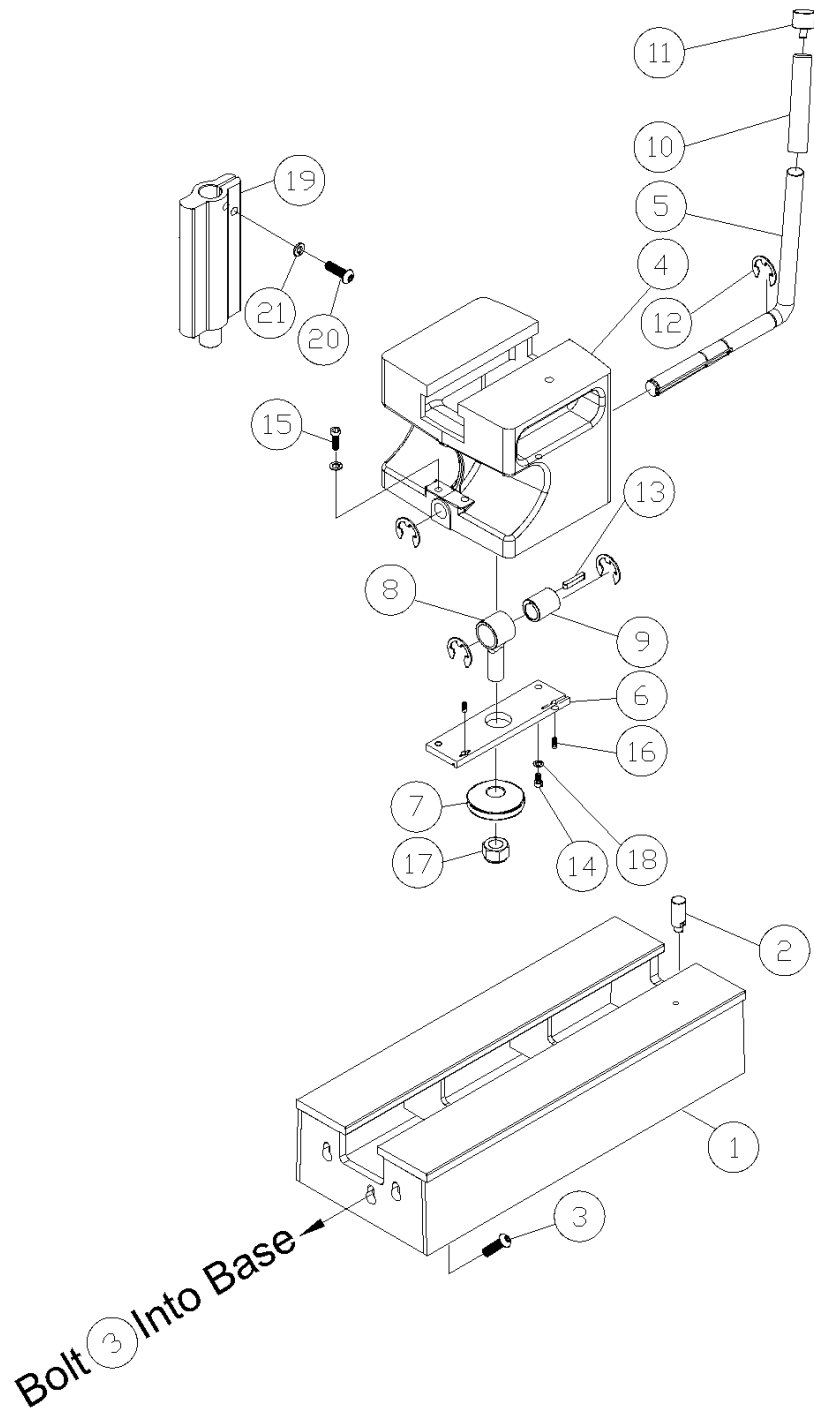

Optional 20" Bed Extension with Riser Block and Tool Rest Extension				
Index	Part Number	Item Description	Specification	Qty
1	PLAREVO1836-301	20" Bed Extension		1
2	PLAREVO1836-147	Stop Bolt		2
3	PLAREVO1836-195	Socket Head Cap Screw	3/8-16UNCx1"	3
4	PLAREVO1836-304	Riser Block		1
5	PLAREVO1836-305	Riser Block Locking Handle		1
6	PLAREVO1836-306	Riser Block Adjusting Plate		1
7	PLAREVO1836-119	Clamp		1
8	PLAREVO1836-114	Clamp Bolt		1
9	PLAREVO1836-115	Sleeve		1
10	PLAREVO1836-116	Rubber Sleeve		1
11	PLAREVO1836-1145	Cap		1
12	MPAREVO1836-189	E-Ring	E15	4
13	PLAREVO1836-185	Key	6x6x30	1
14	PLAREVO1836-194	Socket Head Button Screw	M8x20	1
15	PLAREVO1836-315	Socket Head Button Screw	M8x50	1
16	PLAREVO1836-199	Set Screw	M8x6	2
17	PLAREVO1836-1110	Nylon Insert Lock Nut	M18x2.5	1
18	PLAREVO1836-1114	Lock Washer	5/16"	2
19	PLAREVO1836-319	Tool rest Extension		1
20	PLAREVO1836-320	Socket Head Button Screw	3/8-16UNCx1-1/4"	1
21	PLAREVO1836-1115	Lock Washer	3/8"	1

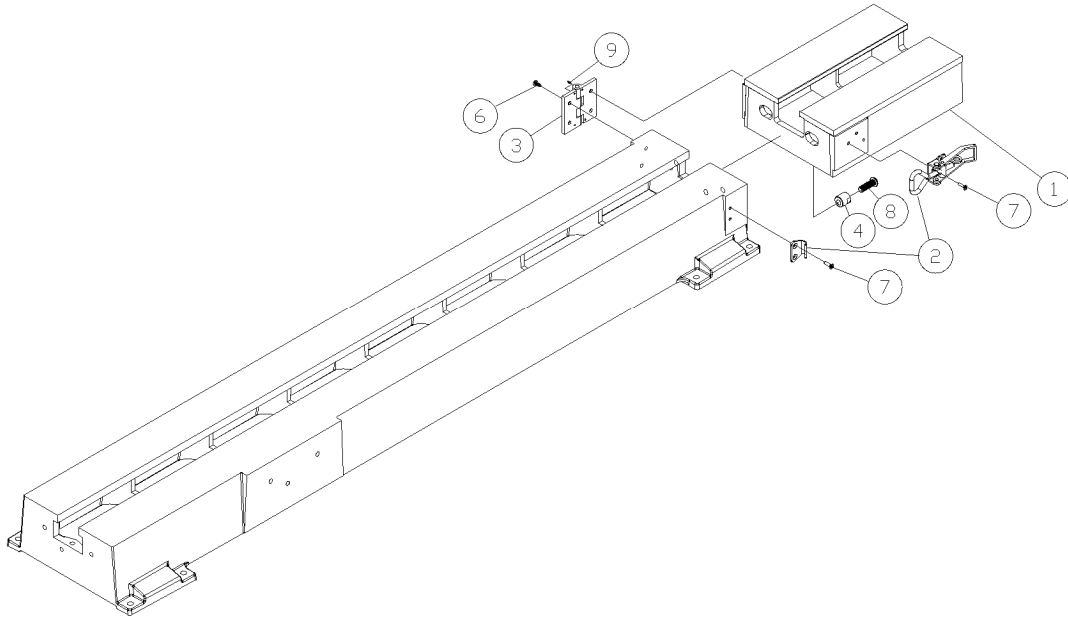

Optional 12" Swing-Away Extension

Index	Part Number	Item Description	Specification	Qty
1	PLAREVO1836-401	12" Bed Extension		1
2	PLAREVO1836-402	Draw Latch Assembly		1
3	PLAREVO1836-403	Hinge		1
4	PLAREVO1836-404	Pin		2
5	PLAREVO1836-147	Stop Bolt		1
6	PLAREVO1836-406	Socket Head Cap Screw	M6x12	4
7	PLAREVO1836-407	Phillips Flat Head Screw	M5x12	5
8	PLAREVO1836-320	Socket Head Button Screw	3/8-16UNCx1-1/4"	2
9	PLAREVO1836-409	Set Screw	3/16-24UNCx3/8"	4

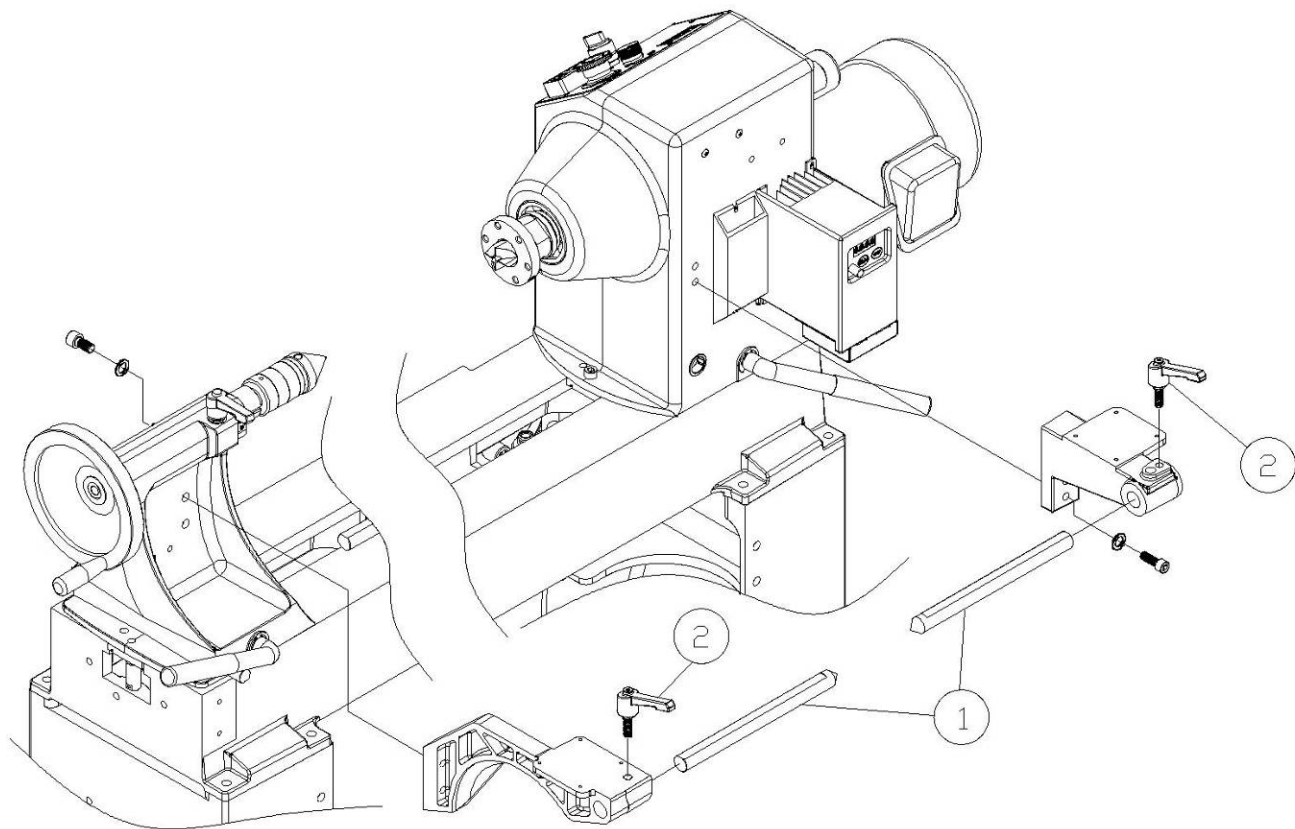

Optional Comparator				
Index	Part Number	Item Description	Specification	Qty
1	PLAREVO1836-501	Center		2
2	PLAREVO1836-502	Lock Handle		2

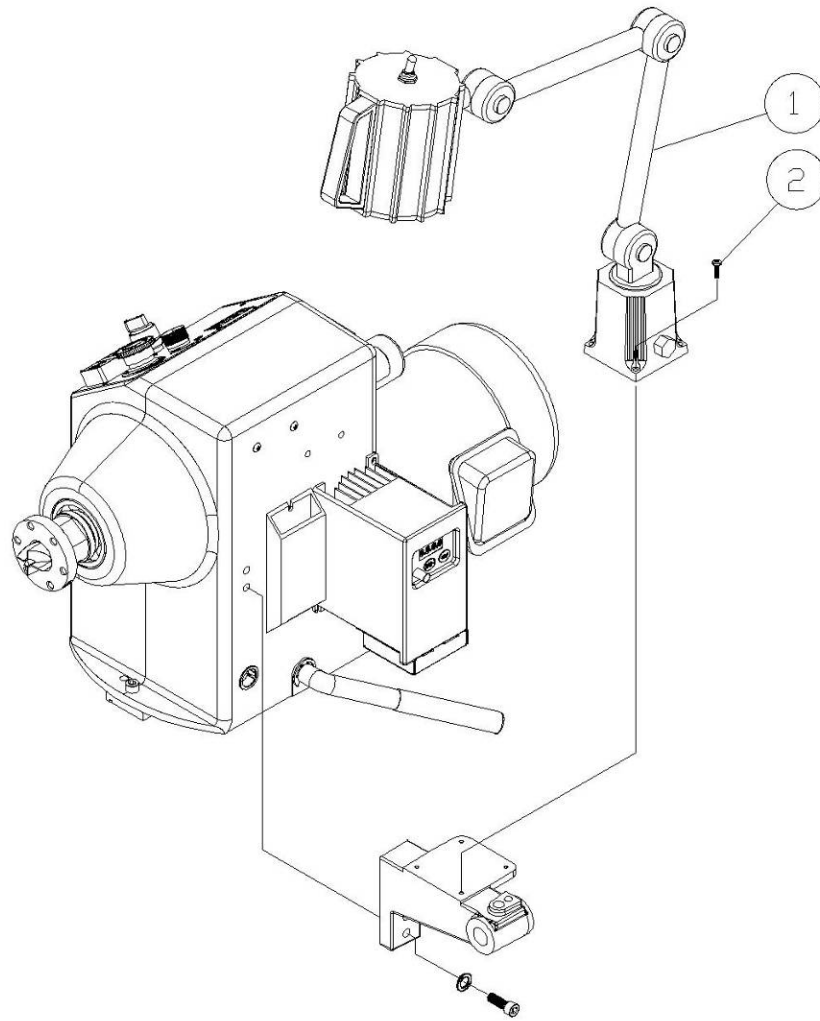

Optional Industrial Flood Light				
Index	Part Number	Item Description	Specification	Qty
1	PLAREVO1836-601	Work Light		1
2	PLAREVO1836-602	Screw	M4x15	4

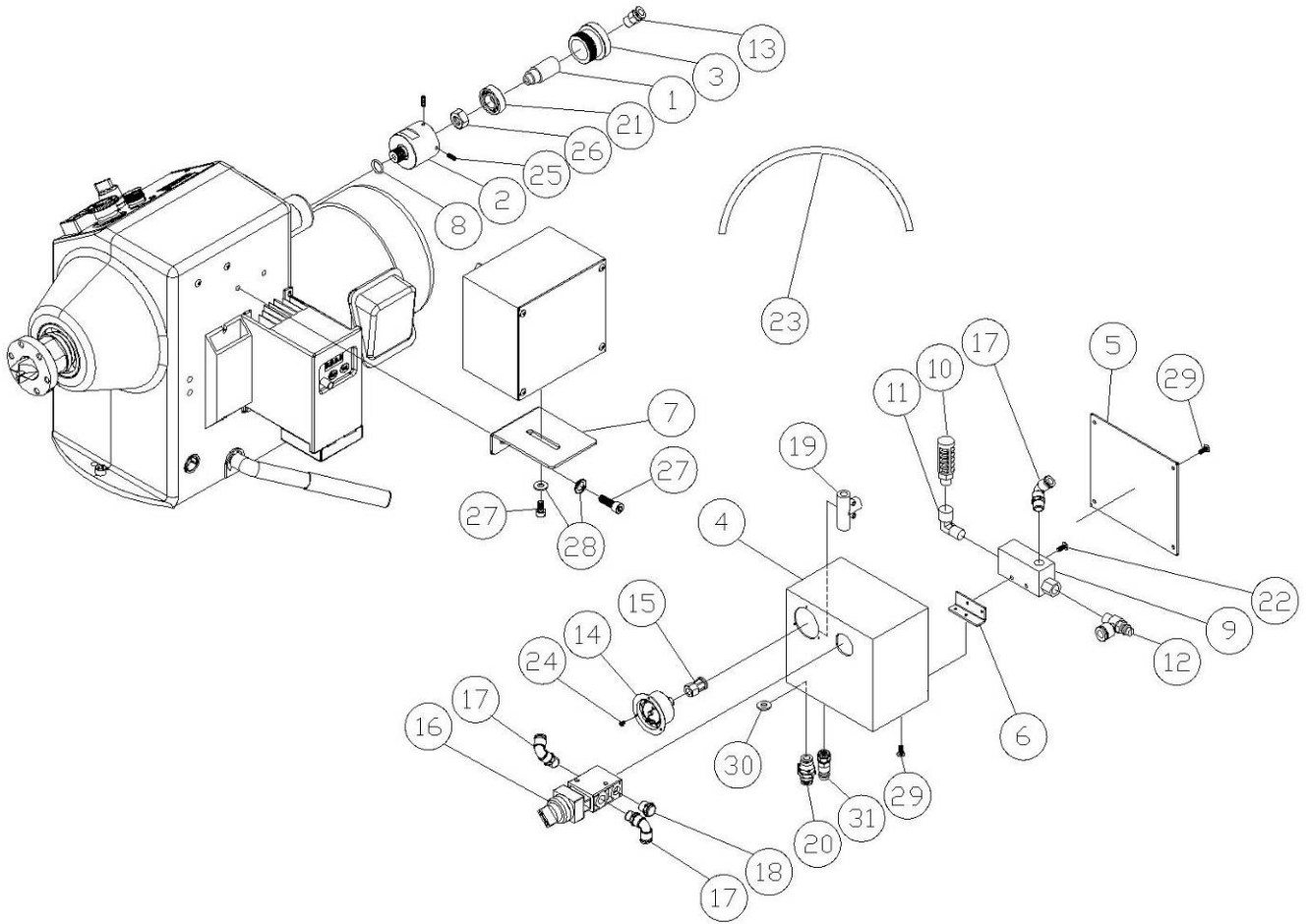

Optional Inverter for Vacuum				
Index	Part Number	Item Description	Specification	Qty
1	PLAREVO1836-801	Connecting Shaft		1
2	PLAREVO1836-802	Vacuum Adaptor Body		1
3	PLAREVO1836-803	Cover		1
4	PLAREVO1836-804	Vacuum System Box		1
5	PLAREVO1836-805	Plate		1
6	PLAREVO1836-806	Vacuum Generator Bracket		1
7	PLAREVO1836-807	Vacuum System Bracket		1
8	PLAREVO1836-808	O-Ring	P14	1
9	PLAREVO1836-809	Vacuum Generator		1
10	PLAREVO1836-810	Silencer		1
11	PLAREVO1836-811	L-Type Fitting		1
12	PLAREVO1836-812	Air Flow Regulator		1
13	PLAREVO1836-813	Quick Release Fitting		1
14	PLAREVO1836-814	Pressure Vacuum Gauge		1
15	PLAREVO1836-815	Gauge Fitting		1
16	PLAREVO1836-816	Vacuum Switch		1
17	PLAREVO1836-817	H-Type Fitting		1
18	PLAREVO1836-818	Flat Type Silencer		1
19	PLAREVO1836-819	T-Type Fitting		1
20	PLAREVO1836-820	Straight Fitting-Female		1
21	PLAREVO1836-821	Ball Bearing	6003ZZ	1
22	PLAREVO1836-822	Screw	M4x30	2
23	PLAREVO1836-823	Air Hose		1
24	PLAREVO1836-824	Screw	M2.5x5	3
25	PLAREVO1836-825	Set Screw	M5x5	2
26	PLAREVO1836-826	Hex Nut	M12	1
27	PLAREVO1836-827	Socket Head Cap Screw	5/16-18UNCx1/2"	4
28	PLAREVO1836-1113	Flat Washer	D8xD18x2t	4
29	PLAREVO1836-829	Screw	M4x10	6
30	PLAREVO1836-830	Flat Washer	D1/2"xD26x2.5t	1
31	PLAREVO1836-831	Quick Fitting- Inlet		1

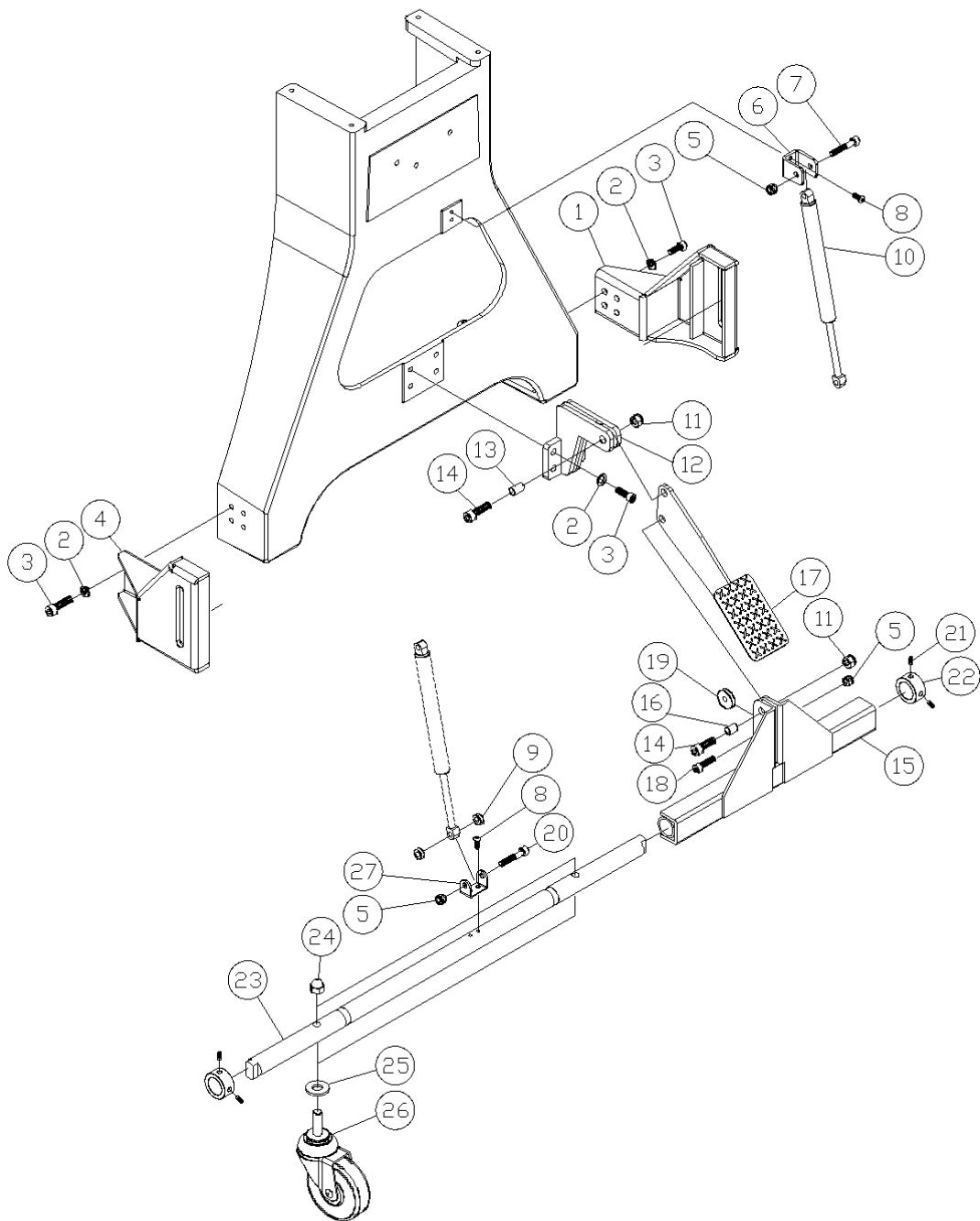

Optional Deluxe Wheel System				
Index	Part Number	Item Description	Specification	Qty
1	PLAREVO1836-901	Support Bracket-Right		2
2	PLAREVO1836-1115	Lock Washer	3/8"	24
3	PLAREVO1836-195	Socket Head Cap Screw	3/8-16UNCx1"	24
4	PLAREVO1836-904	Support Bracket-Left		2
5	PLAREVO1836-905	Nylon Insert Lock Nut	M8x1.25	6
6	PLAREVO1836-906	Support Bracket		2
7	PLAREVO1836-907	Socket Head Cap Screw	M8X45mm	2
8	PLAREVO1836-1146	Socket Head Button Screw	1/4-20UNCx3/8"	8
9	PLAREVO1836-909	Spacer		4
10	PLAREVO1836-910	Cylinder		2
11	PLAREVO1836-911	Nylon Insert Lock Nut	M10x1.5	4
12	PLAREVO1836-912	Support Bracket		2
13	PLAREVO1836-913	Bushing		2
14	PLAREVO1836-914	Socket Head Cap Screw	M10x35mm	4
15	PLAREVO1836-915	Connecting rod		2
16	PLAREVO1836-916	Bushing		2
17	PLAREVO1836-917	Foot Brake		2
18	PLAREVO1836-918	Socket Head Cap Screw	M8X30mm	2
19	PLAREVO1836-919	Bushing		2
20	PLAREVO1836-920	Socket Head Cap Screw	M8X50mm	2
21	PLAREVO1836-199	Set Screw	M8x6	8
22	PLAREVO1836-922	Spacer		4
23	PLAREVO1836-923	Rod		2
24	PLAREVO1836-924	Nut	1/2"-12UNC	4
25	PLAREVO1836-925	Flat Washer	1/2"	4
26	PLAREVO1836-926	Caster		4
27	PLAREVO1836-927	Support Bracket		2

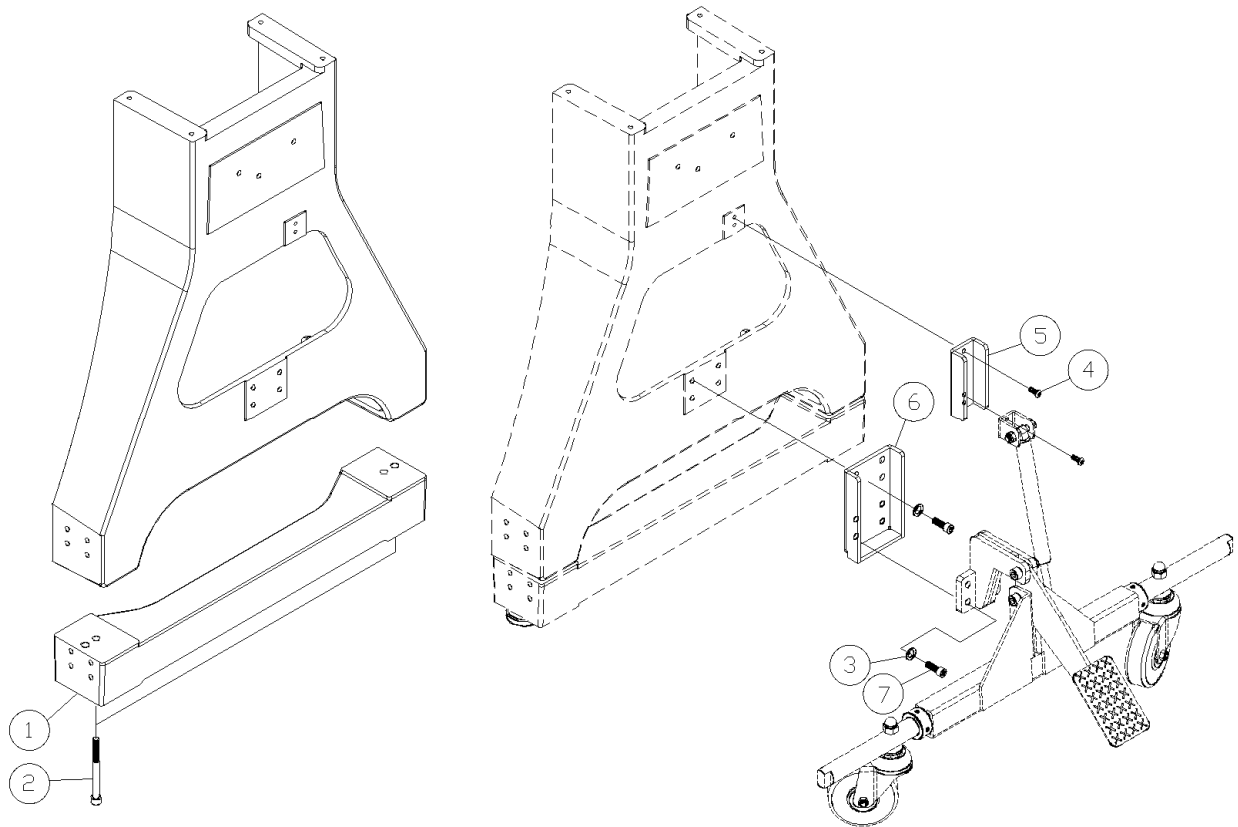

Optional 3" Riser Blocks				
Index	Part Number	Item Description	Specification	Qty
1	PLAREVO1836-701	3" Riser Blocks		2
2	PLAREVO1836-702	Socket Head Cap Screw	3/8-16UNCx3-1/2"	4
3	PLAREVO1836-1115	Lock Washer	3/8"	8
4	PLAREVO1836-1146	Socket Head Button Screw	1/4-20UNCx3/8"	4
5	PLAREVO1836-705	Support Bracket		2
6	PLAREVO1836-706	Support Bracket		2
7	PLAREVO1836-707	Socket Head Cap Screw	3/8-16UNCx3/4"	8

INDEX SYSTEM

	1	2	3	4	5	6	7	8	9	10	11	12
14	25.7	51.4	77.1	102.9	128.6	154.3	180	205.7	231.4	257.1	282.9	308.6
36	10	20	30	40	50	60	70	80	90	100	110	120
48	7.5	15	22.5	30	37.5	45	52.5	60	67.5	75	82.5	90

	13	14	15	16	17	18	19	20	21	22	23	24
14	334.3	360										
36	130	140	150	160	170	180	190	200	210	220	230	240
48	97.5	105	112.5	120	127.5	135	142.5	150	157.5	165	172.5	180

	25	26	27	28	29	30	31	32	33	34	35	36
14												
36	250	260	270	280	290	300	310	320	330	340	350	360
48	187.5	195	202.5	210	217.5	225	232.5	240	247.5	255	262.5	270

	37	38	39	40	41	42	43	44	45	46	47	48
14												
36												
48	277.5	285	292.5	300	307.5	315	322.5	330	337.5	345	352.5	360

Circle(°)	Segment	Average
360	14	25.7143
	36	10
	48	7.5

LAGUNA

2072 Alton Parkway. Irvine, CA 92606
Ph: 800.234.1976 | www.lagunatools.com

Laguna Tools is not responsible for errors or omissions.
Specifications subject to change. Machines may be shown with optional accessories.

© 2018, Laguna Tools, Inc. LAGUNA® and the LAGUNA Logo® are the
registered trademarks of Laguna Tools, Inc. All rights reserved.