

20" Floor Drill Press



Operator's Manual

Record the serial number and date of purchase in your manual for future reference.

The serial number can be found on the specification label on the rear of your machine.

Serial Number: _____ Date of purchase: _____

For technical support or parts questions, email techsupport@rikontools.com or call toll free at (877)884-5167

TABLE OF CONTENTS

Specifications.....	2
Safety Instructions	3 - 6
Contents of Package	7
Getting To Know Your Machine	8
Installation	8
Assembly	9 - 12
Adjustments.....	12 - 15
Operation	15
Maintenance	16
Electricals & Wiring Diagram	5 & 16
Troubleshooting	17
Parts Diagrams	18 - 20
Parts List	21
Accessories	22
Notes	22
Warranty	23

SPECIFICATIONS

Motor	1 HP, TEFC
Motor Speed (no load).....	1,720 RPM
Volts	120 V
Amps, Hertz	13.5 A, 60 Hz
Swing	20"
Chuck Size	5-20mm (7/32-3/4")
Chuck Taper	JT3
Drilling Capacity	1"
Spindle Travel	4-3/4"
Spindle Taper	MT3
Head Rotates	360°
Speed Range (RPM)	180 - 3865
Speeds	12
Quill Diameter	3" (75mm)
Table Size	16-3/4" x 18-3/4"
Table Tilts	90° Left & Right
Table Rotates	360°
Maximum Chuck to Table	24-1/4"
Maximum Chuck to Base	43-3/4"
Column Diameter	3-5/8" (92mm)
Height	67"
Base Size	22-3/4" x 17-1/2"
Net Weight	250 lbs.

NOTE: The specifications, photographs, drawings and information in this manual represent the current model when the manual was prepared. Changes and improvements may be made at any time, with no obligation on the part of Rikon Power Tools, Inc. to modify previously delivered units. Reasonable care has been taken to ensure that the information in this manual is correct, to provide you with the guidelines for the proper safety, assembly and operation of this machine.

SAFETY INSTRUCTIONS

IMPORTANT! Safety is the single most important consideration in the operation of this equipment. **The following instructions must be followed at all times.** Failure to follow all instructions listed below may result in electric shock, fire, and/or serious personal injury.

There are certain applications for which this tool was designed. We strongly recommend that this tool not be modified and/or used for any other application other than that for which it was designed. If you have any questions about its application, do not use the tool until you have contacted us and we have advised you.

SAFETY SYMBOLS



SAFETY ALERT SYMBOL: Indicates DANGER, WARNING, or CAUTION. This symbol may be used in conjunction with other symbols or pictographs.



Indicates an imminently hazardous situation, which, if not avoided, could result in death or serious injury.



Indicates a potentially hazardous situation, which, if not avoided, could result in death or serious injury.



Indicates a potentially hazardous situation, which, if not avoided, could result in minor or moderate injury.

NOTICE: Shown without Safety Alert Symbol indicates a situation that may result in property damage.

GENERAL SAFETY

KNOW YOUR POWER TOOL. Read the owner's manual carefully. Learn the tool's applications, work capabilities, and its specific potential hazards.

BEFORE USING YOUR MACHINE

To avoid serious injury and damage to the tool, read and follow all of the Safety and Operating Instructions before operating the machine.

1. Some dust created by using power tools contains chemicals known to the State of California to cause cancer, birth defects, or other reproductive harm.

Some examples of these chemicals are:

- Lead from lead-based paints.
- Crystalline silica from bricks, cement, and other masonry products.
- Arsenic and chromium from chemically treated lumber.

Your risk from these exposures varies, depending on how often you do this type of work. To reduce your exposure to these chemicals: work in a well ventilated area and work with approved safety equipment, such as those dust masks that are specially designed to filter out microscopic particles.

2. **READ** the entire Owner's Manual. **LEARN** how to use the tool for its intended applications.

3. **GROUND ALL TOOLS.** If the tool is supplied with a 3 prong plug, it must be plugged into a 3-contact electrical receptacle. The 3rd prong is used to ground the tool and provide protection against accidental electric shock. **DO NOT** remove the 3rd prong. See Grounding Instructions on the following pages.

4. **AVOID A DANGEROUS WORKING ENVIRONMENT.** **DO NOT** use electrical tools in a damp environment or expose them to rain.

5. **DO NOT** use electrical tools in the presence of flammable liquids or gases.

6. **ALWAYS** keep the work area clean, well lit, and organized. **DO NOT** work in an environment with floor surfaces that are slippery from debris, grease, and wax.

7. **KEEP VISITORS AND CHILDREN AWAY. DO NOT** permit people to be in the immediate work area, especially when the electrical tool is operating.

8. **DO NOT FORCE THE TOOL** to perform an operation for which it was not designed. It will do a safer and higher quality job by only performing operations for which the tool was intended.

9. **WEAR PROPER CLOTHING. DO NOT** wear loose clothing, gloves, neckties, or jewelry. These items can get caught in the machine during operations and pull the operator into the moving parts. The user must wear a protective cover on their hair, if the hair is long, to prevent it from contacting any moving parts.

10. **CHILDPROOF THE WORKSHOP AREA** by removing switch keys, unplugging tools from the electrical receptacles, and using padlocks.

11. **ALWAYS UNPLUG THE TOOL FROM THE ELECTRICAL RECEPTACLE** when making adjustments, changing parts or performing any maintenance.

SAFETY INSTRUCTIONS

12. KEEP PROTECTIVE GUARDS IN PLACE AND IN WORKING ORDER.

13. AVOID ACCIDENTAL STARTING. Make sure that the power switch is in the “OFF” position before plugging in the power cord to the electrical receptacle.

14. REMOVE ALL MAINTENANCE TOOLS from the immediate area prior to turning “ON” the machine.

15. USE ONLY RECOMMENDED ACCESSORIES. Use of incorrect or improper accessories could cause serious injury to the operator and cause damage to the tool. If in doubt, check the instruction manual that comes with that particular accessory.

16. NEVER LEAVE A RUNNING TOOL UNATTENDED. Turn the power switch to the “OFF” position. **DO NOT** leave the tool until it has come to a complete stop.

17. DO NOT STAND ON A TOOL. Serious injury could result if the tool tips over, or you accidentally contact the tool.

18. DO NOT store anything above or near the tool where anyone might try to stand on the tool to reach it.

19. MAINTAIN YOUR BALANCE. DO NOT extend yourself over the tool. Wear oil resistant rubber soled shoes. Keep floor clear of debris, grease, and wax.

20. MAINTAIN TOOLS WITH CARE. Always keep tools clean and in good working order. Keep all blades and tool bits sharp, dress grinding wheels and change other abrasive accessories when worn.

21. EACH AND EVERY TIME, CHECK FOR DAMAGED PARTS PRIOR TO USING THE TOOL. Carefully check all guards to see that they operate properly, are not damaged, and perform their intended functions. Check for alignment, binding or breaking of moving parts. A guard or other part that is damaged should be immediately repaired or replaced.

22. DO NOT OPERATE TOOL WHILE TIRED, OR UNDER THE INFLUENCE OF DRUGS, MEDICATION OR ALCOHOL.

23. SECURE ALL WORK. Use clamps or jigs to secure the work piece. This is safer than attempting to hold the work piece with your hands.

24. STAY ALERT, WATCH WHAT YOU ARE DOING, AND USE COMMON SENSE WHEN OPERATING A POWER TOOL.

A moment of inattention while operating power tools may result in serious personal injury.

25. ALWAYS WEAR A DUST MASK TO PREVENT INHALING DANGEROUS DUST OR AIRBORNE PARTICLES, including wood dust, crystalline silica dust and asbestos dust. Direct particles away from face and body. Always operate tool in well ventilated area and provide for proper dust removal. Use dust collection system wherever possible. Exposure to the dust may cause serious and permanent respiratory or other injury, including silicosis (a serious lung disease), cancer, and death. Avoid breathing the dust, and avoid prolonged contact with dust. Allowing dust to get into your mouth or eyes, or lay on your skin may promote absorption of harmful material. Always use properly fitting NIOSH/OSHA approved respiratory protection appropriate for the dust exposure, and wash exposed areas with soap and water.

26. USE A PROPER EXTENSION CORD IN GOOD CONDITION. When using an extension cord, be sure to use one heavy enough to carry the current your product will draw. The table on the following page shows the correct size to use depending on cord length and nameplate amperage rating. If in doubt, use the next heavier gauge. The smaller the gauge number, the larger diameter of the extension cord. If in doubt of the proper size of an extension cord, use a shorter and thicker cord. An undersized cord will cause a drop in line voltage resulting in a loss of power and overheating.
USE ONLY A 3-WIRE EXTENSION CORD THAT HAS A 3-PRONG GROUNDING PLUG AND A 3-POLE RECEPTACLE THAT ACCEPTS THE TOOL’S PLUG.

27. ADDITIONAL INFORMATION regarding the safe and proper operation of this product is available from:

- Power Tool Institute
1300 Summer Avenue
Cleveland, OH 44115-2851
www.powertoolinstitute.org
- National Safety Council
1121 Spring Lake Drive
Itasca, IL 60143-3201
www.nsc.org
- American National Standards Institute
25 West 43rd Street, 4th Floor
New York, NY 10036
www.ansi.org
- ANSI 01.1 Safety Requirements for Woodworking Machines and the U.S. Department of Labor regulations
www.osha.gov

28. SAVE THESE INSTRUCTIONS. Refer to them frequently and use them to instruct others.

SAFETY INSTRUCTIONS

ELECTRICAL SAFETY

⚠ WARNING: THIS TOOL MUST BE GROUNDED WHILE IN USE TO PROTECT THE OPERATOR FROM ELECTRIC SHOCK.

IN THE EVENT OF A MALFUNCTION OR BREAKDOWN, grounding provides the path of least resistance for electric current and reduces the risk of electric shock. This tool is equipped with an electric cord that has an equipment grounding conductor and requires a grounding plug (not included). The plug **MUST** be plugged into a matching electrical receptacle that is properly installed and grounded in accordance with **ALL** local codes and ordinances.

DO NOT MODIFY ANY PLUG. If it will not fit the electrical receptacle, have the proper electrical receptacle installed by a qualified electrician.

IMPROPER ELECTRICAL CONNECTION of the equipment grounding conductor can result in risk of electric shock. The conductor with the green insulation (with or without yellow stripes) is the equipment grounding conductor. **DO NOT** connect the equipment grounding conductor to a live terminal if repair or replacement of the electric cord or plug is necessary.

CHECK with a qualified electrician or service personnel if you do not completely understand the grounding instructions, or if you are not sure the tool is properly grounded when installing or replacing a plug.

USE ONLY A 3-WIRE EXTENSION CORD THAT HAS THE PROPER TYPE OF A 3-PRONG GROUNDING PLUG THAT MATCHES THE MACHINE'S 3-PRONG PLUG AND ALSO THE 3-POLE RECEPTACLE THAT ACCEPTS THE TOOL'S PLUG. *

REPLACE A DAMAGED OR WORN CORD IMMEDIATELY.

This tool is intended for use on a circuit that has an electrical receptacle as shown in **FIGURE A**. It shows a 3-wire electrical plug and electrical receptacle that has a grounding conductor. If a properly grounded electrical receptacle is not available, an adapter as shown in **FIGURE B** can be used to temporarily connect this plug to a 2-contact ungrounded receptacle. The adapter has a rigid lug extending from it that **MUST** be connected to a permanent earth ground, such as a properly grounded receptacle box. **THIS ADAPTER IS PROHIBITED IN CANADA.**

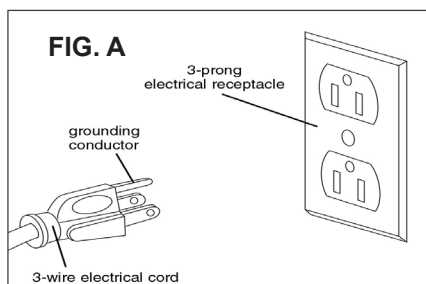

EXTENSION CORDS

⚠ WARNING: THE USE OF AN EXTENSION CORD WITH THIS MACHINE IS NOT RECOMMENDED. For best power and safety, plug the machine directly into a dedicated, grounded electrical outlet that is within the supplied cord length of the machine.

If an extension cord needs to be used, it should only be for a limited operation of the machine. The extension cord should be as short as possible in length, and have a minimum gauge size of 14AWG.

⚠ WARNING: Check extension cords before each use. If damaged replace immediately. Never use a tool with a damaged cord, since touching the damaged area could cause electrical shock, resulting in serious injury.

Use a proper extension cord. Only use cords listed by Underwriters Laboratories (UL). Other extension cords can cause a drop in line voltage, resulting in a loss of power and overheating of tool. When operating a power tool outdoors, use an outdoor extension cord marked "W-A" or "W". These cords are rated for outdoor use and reduce the risk of electric shock.

MINIMUM RECOMMENDED GAUGE FOR EXTENSION CORDS (AWG)

120 VOLT OPERATION ONLY				
	25' LONG	50' LONG	100' LONG	150' LONG
0 to 6 Amps	18 AWG	16 AWG	16 AWG	14 AWG
6 to 10 Amps	18 AWG	16 AWG	14 AWG	12 AWG
10 to 12 Amps	16 AWG	16 AWG	14 AWG	12 AWG

⚠ WARNING: Keep the extension cord clear of the working area. Position the cord so that it will not get caught on lumber, tools or other obstructions while you are working with your power tool.

* Canadian electrical codes require extension cords to be certified SJT type or better.

** The use of an adapter in Canada is not acceptable.

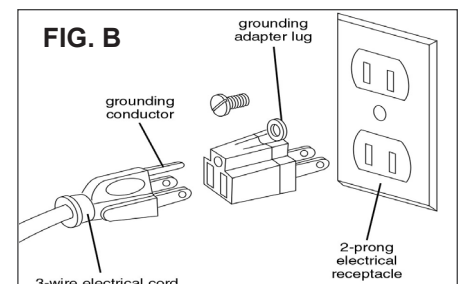

SAFETY INSTRUCTIONS

SPECIFIC SAFETY INSTRUCTIONS FOR DRILL PRESSES

This machine is intended for the drilling of wood, composite materials, plastics, ferrous and non-ferrous metals. The permissible workpiece dimensions must be observed (see Technical Specification). Any other use not as specified, including modification of the machine or use of parts not tested and approved by the equipment manufacturer, can cause unforeseen damage and invalidate the warranty.

ATTENTION: Use of this drill press still presents risks that cannot be eliminated by the manufacturer. Therefore, the user must be aware that wood working machines are dangerous if not used with care and all safety precautions are adhered to.

1. Do not operate the Drill Press until it is assembled and you have read all of the instructions.
2. Do not operate the Drill Press unless you are familiar with its safe operation. If you are not familiar with the operation of a Drill Press seek advice from your supervisor, instructor or other qualified individual.
3. If you are using a bench top Drill Press, it must be securely fastened to a stand or bench.
4. If you are operating a floor Drill Press it must be securely fastened to the floor.
5. Always clear the table and work area before turning on the Drill Press.
6. Always use drill bits, cutting tools and accessories with a 1/2" shank or less.
7. Never place hands near the drill bit, cutting tool or accessory while operating the Drill Press.
8. Always wear approved, safety eye wear and hearing protection while operating the Drill Press.
9. Never wear loose clothing, gloves or ties while operating the Drill Press. Tie loose hair back.
10. Always wear a dust mask and use adequate dust collection and proper ventilation.
11. Always have a firm footing while operating the Drill Press.
12. Always keep the work surface and work areas clear of debris.
13. Never attempt to do set-up work, assembly or layout work on the Drill Press while it is in operation.
14. Always lock all table, column and head locks before turning on the Drill Press.
15. Never start the Drill Press with the drill bit, cutting tool or accessory in contact with the work piece.
16. Never operate the Drill Press with a damaged drill bit, cutting tool or accessory.
17. Always check that the drill bit, cutting tool or accessory is held tight in the chuck.
18. Never operate the Drill Press with the chuck key in the chuck.
19. Always adjust the depth stop to avoid drilling into the table surface.
20. Never drill material unless it is properly supported. Non flat work pieces require additional support.
21. Always clamp the work piece to the table.
22. Always support large work pieces at the same height as the table.
23. Never remove the work piece or clear the table until the Drill Press comes to a complete stop.
24. Never operate the Drill Press with missing, damaged, worn, loose or defective parts.
25. Never adjust, change speeds or perform maintenance on the Drill Press while it is operating.
26. Always clean the work surface and work area when finished operating the Drill Press.
27. Always disconnect the power when adjusting or performing maintenance on the Drill Press.
28. Always disconnect the power when finished using the Drill Press to prevent accidental operation.

SAVE THESE INSTRUCTIONS. Refer to them often.

This owner's manual is not a teaching aid. Use of this owner's manual is intended to show assembly, adjustments, and general use.

California Proposition 65 Warnings



WARNING: Drilling, sawing, sanding or machining wood products can expose you to wood dust, a substance known to the State of California to cause cancer. Avoid inhaling wood dust or use a dust mask or other safeguards for personal protection. For more information go to www.P65Warnings.ca.gov/wood.



WARNING: This product can expose you to chemicals including Dibutyl phthalate, which is known to the State of California to cause birth defects or other reproductive harm.

For more information go to www.P65Warnings.ca.gov/wood.

CONTENTS OF PACKAGE

Model #30-240 20" Floor Drill Press is shipped complete in one box.

Unpacking and Clean-up

1. Carefully remove all contents from the shipping carton. Compare the contents with the list of contents to make sure that all of the items are accounted for, before discarding any packing material. Place parts on a protected surface for easy identification and assembly. If any parts are missing or broken, please call RIKON Customer Service (877-884-5167) as soon as possible for replacements. DO NOT turn your machine ON if any of these items are missing. You may cause injury to yourself or damage to the machine.
2. Report any shipping damage to your local distributor. Take photographs for any possible insurance claims.
3. Clean all rust protected surfaces with ordinary house hold type grease or spot remover. Do not use; gasoline, paint thinner, mineral spirits, etc. These may damage painted surfaces.
4. Apply a coat of paste wax to the table to prevent rust. Wipe all parts thoroughly with a clean dry cloth.
5. Set packing material and shipping carton aside. Do not discard until the machine has been set up and is running properly.

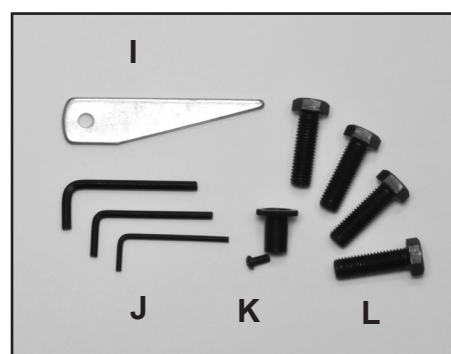
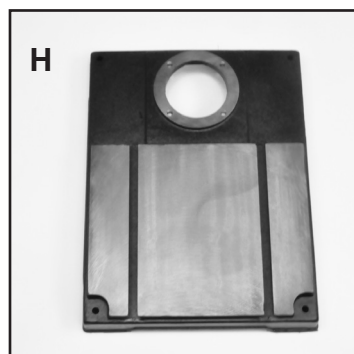
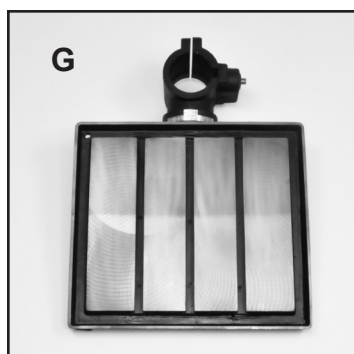
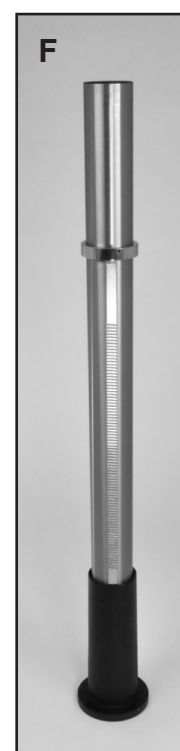

TABLE OF LOOSE PARTS

Item	Part Name
A	Motor & Head Assembly (*)
B	Table Crank Handle
C	Locking Lever Handle
D	5/8" Keyed Chuck & Key
E	Feed Handles (3)
F	Column Assembly
G	Table Assembly

Item	Part Name
H	Base
I	Drift Key
J	Hex Wrenches - 3, 4, 5mm
K	Head Cover Knob & Screw
L	Hex Bolts (4)
M	Manual (not shown)

* Chuck Arbor Shown Pre-installed in the Spindle

GETTING TO KNOW YOUR MACHINE

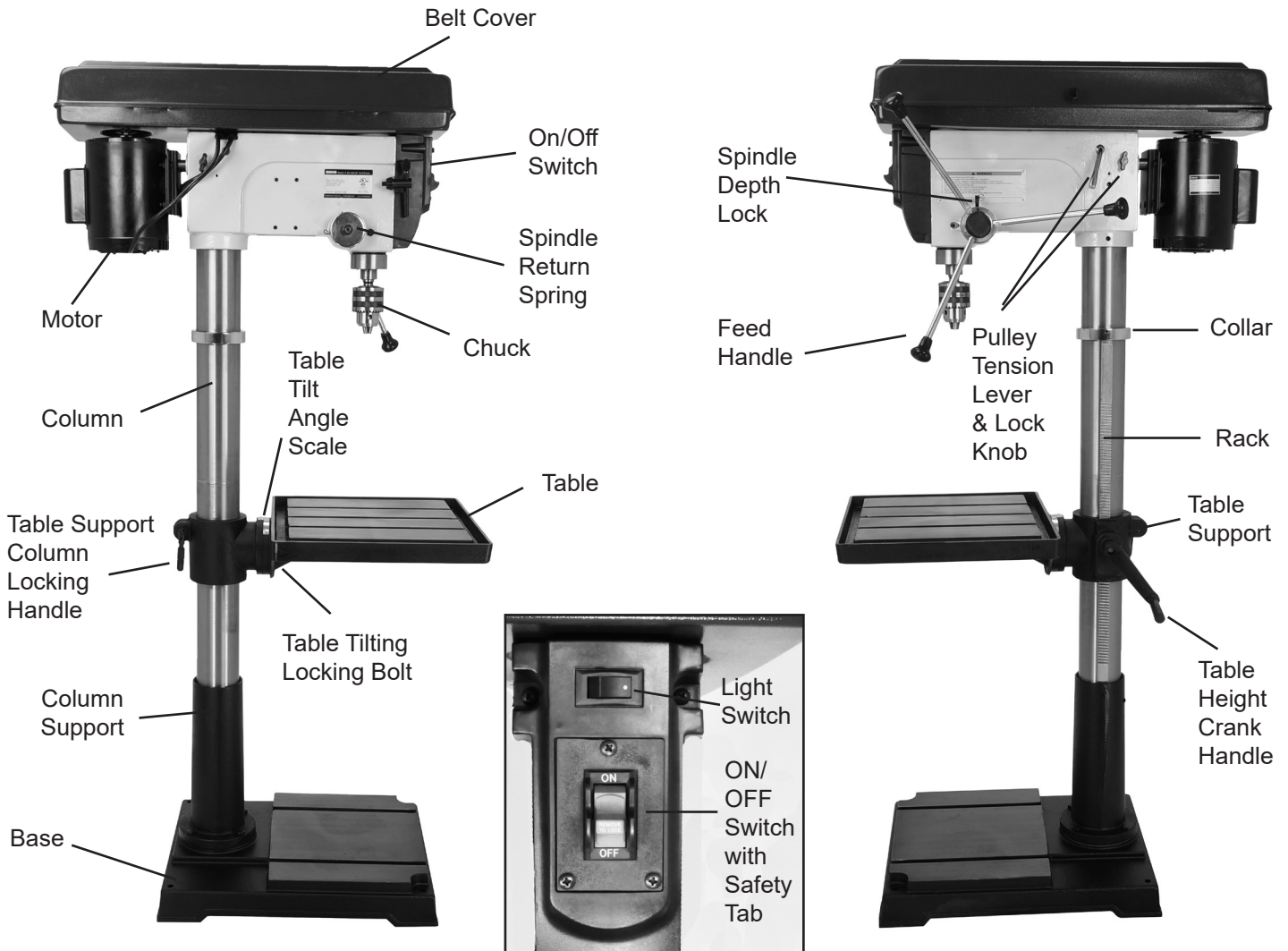

INSTALLATION

MOVING & INSTALLING THE DRILL PRESS

CAUTION When moving the assembled Drill Press, at least two people are recommended. The machine is very heavy, and top heavy. Tilt the drill press backwards so that one person can hold the head section. Then the base can be lifted by the second person, and the machine moved to the desired new location. **DO NOT** move or carry the Drill Press with the work table, chuck or operating handles, as this may damage the machine.

1. Position the machine on a solid, level bench that is located in an area that has ample space in front and to both sides of the drill press for the moving of lumber and projects to be drilled.

2. Align the machine so that during use, any kickback will not face aisles, doorways, or other work areas that bystanders may be in. Do not locate or use the machine in damp or wet conditions.

3. If possible, secure the machine to the floor with lag screws or other fasteners (not supplied). This will ensure the stability of the machine and reduce any possible vibration during use. If this is not possible, the base can be bolted to a larger piece of plywood to help stabilize the machine. **DO NOT** use a mobile base with this machine.

4. For best power and safety, the Drill Press should be directly plugged into a dedicated grounded electrical outlet that is within the supplied cord length of the machine. The use of an extension cord is not recommended.

ASSEMBLY

Additional Tools Needed for Assembly

- #2 Phillips Screwdriver
- 18mm (11/16") or Adjustable Wrench
- Mallet or Hammer with Piece of Wood

⚠ WARNING THE MACHINE MUST NOT BE PLUGGED IN AND THE POWER SWITCH MUST BE IN THE OFF POSITION UNTIL ASSEMBLY IS COMPLETE.

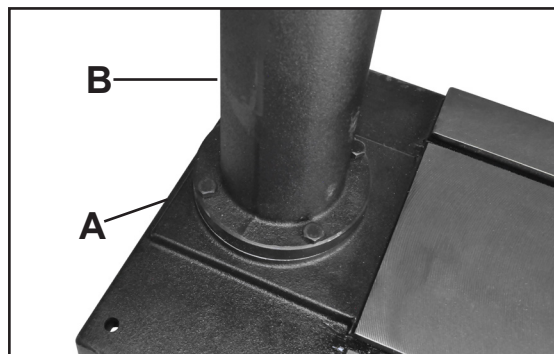

Figure 1

BASE AND COLUMN ASSEMBLY

1. Place the base (A-Fig. 1) on a level floor where the machine will be used.
2. Attach the column (B-Fig.1) to the base (A-Fig. 1) using four M12x40 hex bolts. Tighten all four bolts with a 18mm, 11/16" or adjustable wrench.

NOTE:

Assistance is needed for this next step. The Table Assembly is very large and heavy to lift.

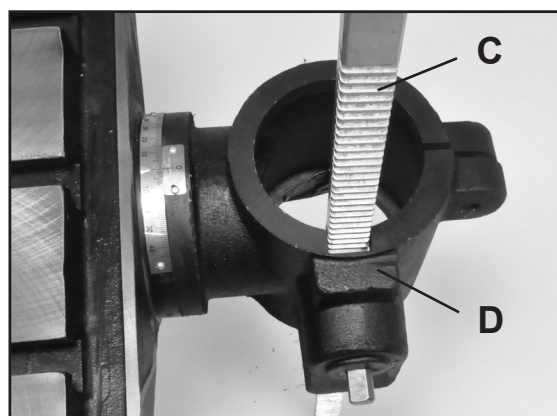

Figure 2

3. Using a hex wrench, remove the assembled Collar and Rack from the column.
4. Place rack (C-Fig. 2) inside the table support bracket (D-Fig. 2), lining up the rack's teeth with the worm gear that is inside of the table bracket.
5. Lift up and slide the table assembly with the rack together onto the column, and slide them down the column until the rack fits back into the column support base.

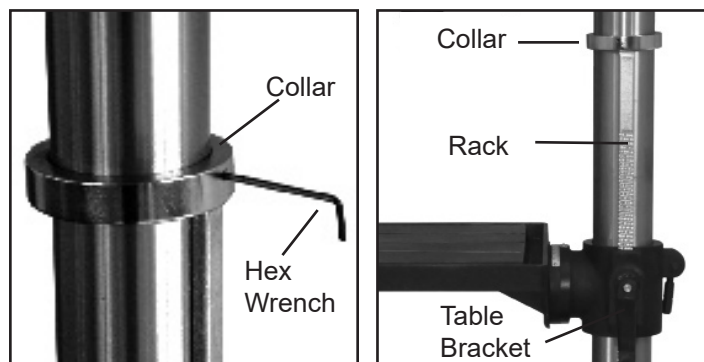

Figure 3

6. Replace the column collar on top of the rack, and secure it in place with a hex wrench. Fig. 3.
7. Install the raising/lowering crank handle onto the table bracket's worm gear shaft with a hex wrench (Figure 4). The handle's set screw must line up and be secured on the flat section of the table support's worm gear shaft.

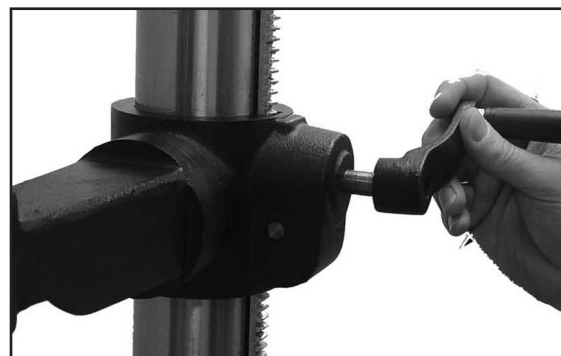

Figure 4

Continued on page 10

ASSEMBLY

Continued from page 9

8. Install the locking lever handle onto the table support bracket. Tightening the locking lever handle secures the table support to the column so that it does not move during the remaining assembly steps, and in normal drill press operation (Figure 5).

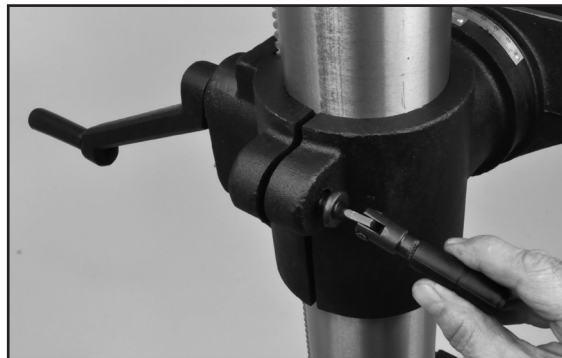

Figure 5

NOTE: Assistance is needed for this next step.

HEAD ASSEMBLY

1. Place the drill press head onto the column as far as it will go (Figure 6).

2. Align the drill press head with the base of the drill press.

3. Tighten the drill press head to the column by tightening the two set screws on the right side of the head as shown (A-Figure 7).

4. Install the 3 feed handles into the threaded holes in the handle hub (Figure 8).

5. Install the belt cover handle knob. Open the belt cover and insert the Phillips head screw through the hole in the lid from the inside. Thread the knob on the outside of the belt cover and tighten it in place on the screw with a screwdriver (Figure 9).

NOTE: Setting the Spindle Speed and Tension of the drive belts is covered on pages 13 and 14.

WARNING THE MACHINE MUST NOT BE PLUGGED IN AND THE POWER SWITCH MUST BE IN THE OFF POSITION UNTIL ASSEMBLY IS COMPLETE.

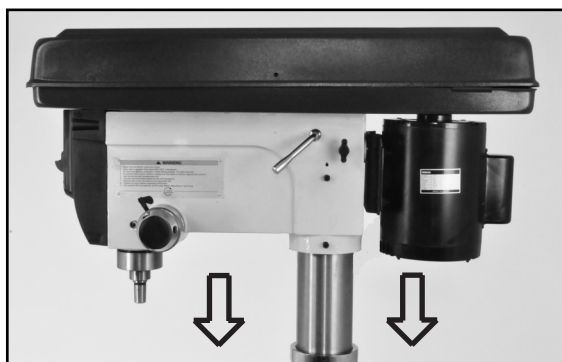

Figure 6



Figure 7



Figure 9



Figure 8

ASSEMBLY

INSTALLING & REMOVING THE CHUCK AND ARBOR

IMPORTANT! It is important that the tapered hole in the chuck, tapered hole in the spindle and both tapered ends of the arbor are free of any grease, oil, lacquer or rust protection.

These tapered surfaces must be absolutely clean for a precision fitting of the parts, so slipping of the chuck during use does not occur unless there is extreme rotational pressure during use. This is a safety feature of this type of friction fit joint.

INSTALLING THE CHUCK AND ARBOR

1. Open the chuck jaws as wide as possible to prevent any damage (Fig. 10).

2. Insert the arbor into the chuck rear as shown (Fig. 11). Make sure that the arbor end and receiving tapered hole in the chuck body rear are clean of grease, oil, rust protection and any burrs or scratches that disrupt the taper surface.

NOTE: The arbor may be already installed in the head assembly/spindle at the factory.

3. Carefully insert the chuck and arbor assembly into the spindle, making sure to align the flat part of the arbor with the spindle (Fig. 12).

NOTE: The arbor may be already installed in the head assembly/spindle at the factory.

4. Using a mallet or wood and hammer, drive the chuck and arbor assembly into the spindle. This will properly seat the chuck assembly on the spindle. (Fig. 13)

CAUTION NEVER HIT THE CHUCK ASSEMBLY WITH A METAL HAMMER. This could damage the chuck assembly or spindle.

5. Close the chuck jaws with the chuck key provided.

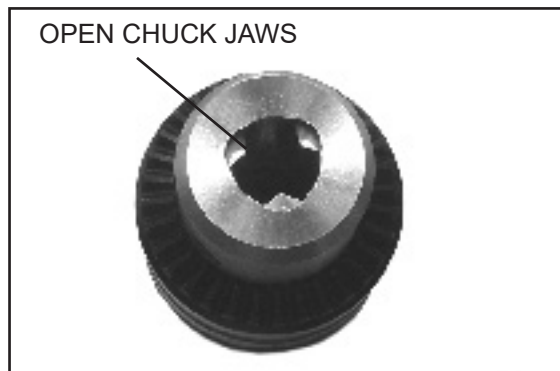

Figure 10

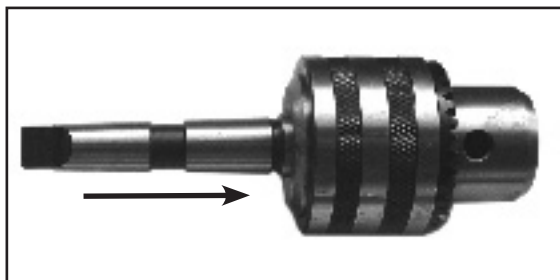

Figure 11

WARNING THE MACHINE MUST NOT BE PLUGGED IN AND THE POWER SWITCH MUST BE IN THE OFF POSITION UNTIL ALL ADJUSTMENTS ARE COMPLETE.



Figure 12

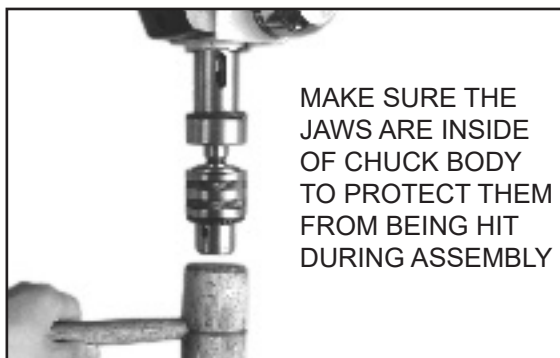

Figure 13

ASSEMBLY

REMOVING THE CHUCK

1. Open the chuck jaws as wide as possible to prevent damage.
2. Lower the spindle until the slot in the spindle is exposed. (Fig. 14)
3. Position the table approximately 1/2" below the extended chuck.
4. Turn the chuck until a through hole is exposed in the spindle.
5. Insert the Key-drift provided into the slot (Fig. 15)
6. Gently tap the key-drift with a mallet to release the chuck.

NOTE: To avoid damage to the chuck, make sure to place a hand below the chuck to catch it as it is released from the spindle.

WARNING THE MACHINE MUST NOT BE PLUGGED IN AND THE POWER SWITCH MUST BE IN THE OFF POSITION UNTIL ASSEMBLY IS COMPLETE.



Figure 14



Figure 15

ADJUSTMENTS

RAISING AND LOWERING THE TABLE

1. Loosen the column lock handle (A-Fig. 16) on the table support bracket (B-Fig. 16).
2. Turn the crank handle (C-Fig. 16) to raise or lower the table to the desired height.
3. Tighten the column lock handle (A-Fig. 16).

NOTE: The table assembly can rotate 360° around the column by loosening the table lock handle and turning the table to the desired position. The column collar's hex nut may have to be loosened to allow the table assembly with the rack to be rotated. Retighten the collar nut when the table is in final position.

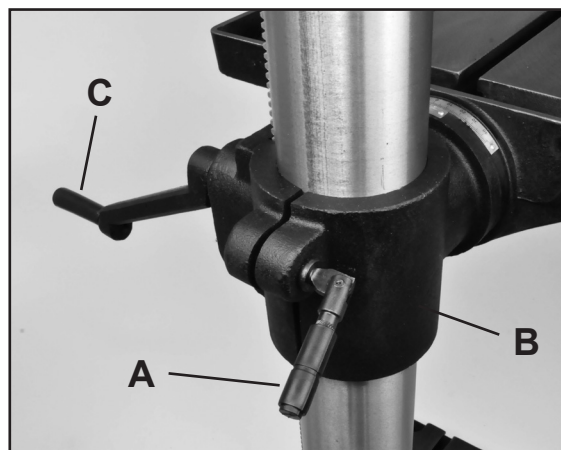

Figure 16

Parts Diagrams and Parts Lists can be found on pages 18 to 21.

ADJUSTMENTS

TILTING THE TABLE

1. Loosen the large nut below the table support arm (A-Fig. 17). This requires a 30mm (1-1/4") socket or adjustable wrench, not included.
2. The small threaded pin with nut below the 30mm nut (B-Fig. 17) positions the table at 90°. *Tighten* the nut to withdraw the pin from its index hole in the support frame so that the table can be tilted from the pre-set 90° position.
3. Tilt the table to the desired angle using the tilt scale and pointer on the bracket to indicate the angle. (Fig. 18).
4. Tighten 30mm nut below the table support arm to secure the table in the angled position.
5. To return the table to the original 90° setting, reverse the steps listed above.

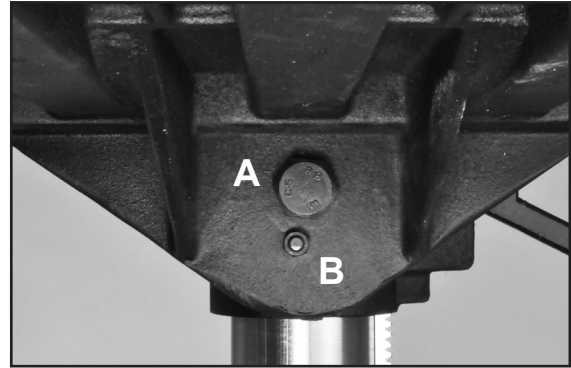

Figure 17

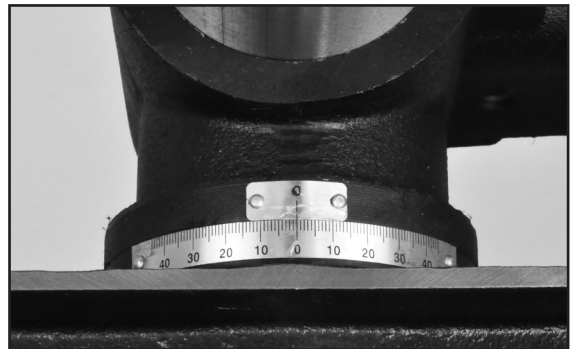

Figure 18

CHANGING SPINDLE SPEEDS

⚠ WARNING THE MACHINE MUST NOT BE PLUGGED IN AND THE POWER SWITCH MUST BE IN THE OFF POSITION UNTIL ALL ADJUSTMENTS ARE COMPLETE.

1. Turn off and disconnect the power to the Drill Press.
2. Open belt cover.
3. Release the tension on the belts so that they can be positioned on the desired pulley steps. Release the locking knobs on the both sides of drill press head by swinging the tension lever from right to left (Figure 19).
4. Choose the desired speed by referring to the speed selection chart under the belt cover.
5. Place the belt on the pulleys in relation to the speed chosen on the speed selection chart starting with the rear motor pulley first (Figure 20).

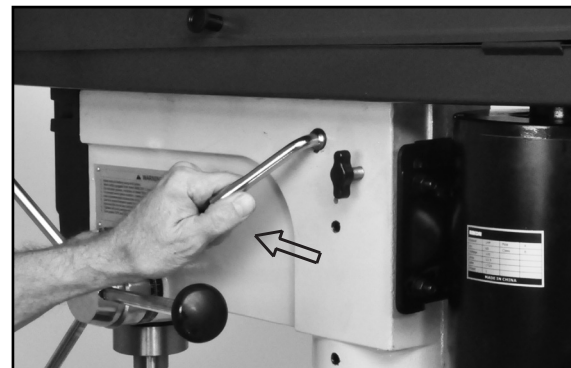

Figure 19

SPINDLE SPEEDS IN R.P.M.											
180	310	320	500								
540	570	1180	1565								
1805	2190	2795	3865								

RECOMMENDED SPEED FOR DRILL SIZE & MATERIAL																
SPEED RANGE (RPM)	WOOD		ZINC DIECAST		ALUM & BRASS		PLASTIC		CAST IRON & BRONZE		STEEL MILD & MALLEABLE		STEEL CAST & MED CARBON		STEEL STAINLESS & TOOL	
	in	mm	in	mm	in	mm	in	mm	in	mm	in	mm	in	mm	in	mm
3865	3/8	9.5	1/4	6.4	7/32	5.6	3/16	4.8	1/8	3.2	3/32	2.4	1/16	1.6	3/64	1.2
1805-2795	5/8	16.0	3/8	9.5	11/32	8.75	5/16	7.9	1/4	6.4	5/32	4.0	1/8	3.2	1/16	1.6
1180-1565	7/8	22.0	1/2	12.5	15/32	12.0	7/16	11.0	11/32	8.75	1/4	6.4	3/16	4.8	1/8	3.2
540-570	1-1/4	31.75	3/4	19.0	11/16	17.5	5/8	16.0	1/2	12.5	3/8	9.5	5/16	7.9	1/4	6.4
320-500	1-5/8	41.4	7/8	22.0	3/4	19.0	13/16	20.5	5/8	16.0	1/2	12.5	7/16	11.0	3/8	9.5
180-310	2	50.8	1	25.4	—	—	—	—	—	—	—	—	9/16	14.5	1/2	12.5

Figure 20

Continued on page 14

ADJUSTMENTS

Continued from page 13

6. Swing back the tension lever until there is approximately 1/2" deflection in the belt (Fig. 21).
7. Tighten the locking knob on the both sides of drill press head.
8. Close the belt guard and reconnect the drill press to the power.

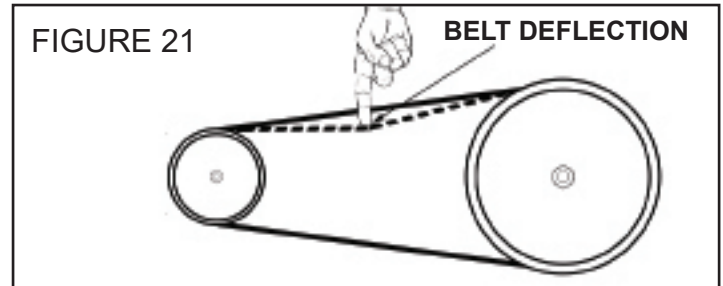

CHANGING THE BELTS

To change a worn belt, follow the same basic steps for Changing Spindle Speeds, pgs 13 & 14:

- Release the belt tension (steps 1-3)
- Remove the old belt from the pulleys
- Install the new belt onto the pulleys
- Reset the belt tension (steps 4-8)

SETTING THE SPINDLE LOCK

1. Loosen the depth stop collar lock (A-Figure 22).
2. Lower the spindle to the desired depth. (Figure 23).
3. Turn the depth stop collar clockwise until the collar stops (B-Figure 22).
4. Tighten the depth stop collar lock.

SETTING THE DRILL DEPTH

1. With the spindle in the up position, loosen the depth stop collar lock (A-Figure 22) as shown.
2. Turn the depth stop collar clockwise until the pointer reads the desired drill depth on the scale (B-Figure 22).
3. Tighten the depth stop collar lock.

⚠ WARNING THE MACHINE MUST NOT BE PLUGGED IN AND THE POWER SWITCH MUST BE IN THE OFF POSITION UNTIL ALL ADJUSTMENTS ARE COMPLETE.

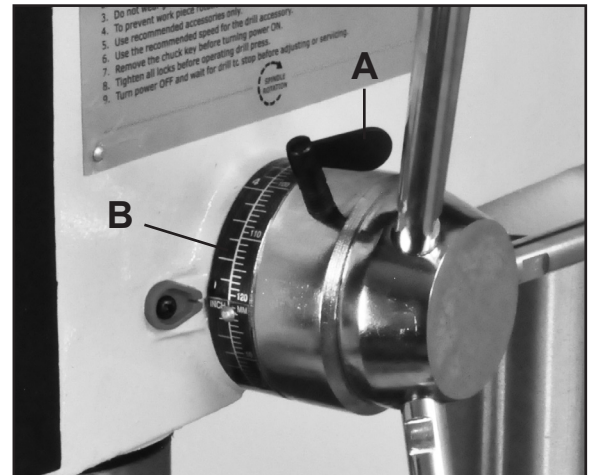

Figure 22



Figure 23

ADJUSTMENTS

SETTING THE RETURN SPRING TENSION

The drill press chuck will automatically return upward to its original starting position when the operating handle is released. The Return Spring Mechanism, Figure 24, has been preset at the factory and should not require any adjustments. However, should the spring tension decline and need adjustment, follow these steps;

1. Disconnect the Drill Press from its power source.
2. Loosen the 2 Spring Cover Nuts (A), but DO NOT REMOVE the nuts from the threaded pin.
3. Carefully pull out the Spring Cover (B) slightly, and keep a firm grasp on it - DO NOT LET THE COVER SPIN as it keeps the spring from unwinding. Also, DO NOT let the spring end (C) disengage from its notch in the cover!
4. Pull out the cover just enough so that the notch in the cover clears the nub on the head casting (D).



WARNING THE MACHINE MUST NOT BE PLUGGED IN AND THE POWER SWITCH MUST BE IN THE OFF POSITION UNTIL ALL ADJUSTMENTS ARE COMPLETE.

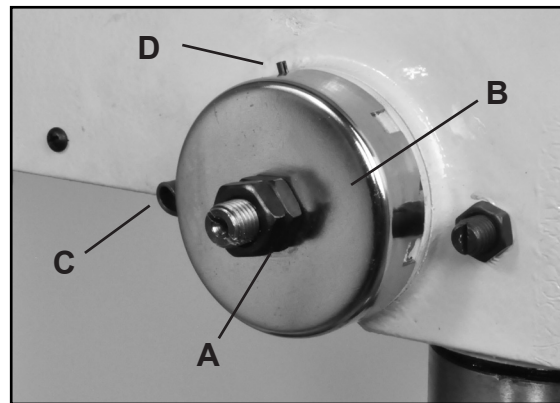

Figure 24

5. Rotate the cover to another notch as needed;
 - *CLOCKWISE* to decrease the spring tension,
 - *COUNTER-CLOCKWISE* to increase spring tension.
6. With the cover in the new position, push it back in place and tighten the spring cover nuts back against the cover to complete the adjustment.

OPERATION

DRILLING SPEEDS

This Drill Press has a speed range from 180 to 3865 RPM. The correct drilling speed for your work depends on a variety of factors:

- a) the workpiece material & hardness
 - wood, composites, plastics or metal
- b) the size of hole diameter
- c) the depth of the hole
- d) the type of drill bit or other cutter needed to make the desired hole diameter and depth
- e) the quality of the bore

We recommend consulting various books, magazine articles, drill bit and material manufacturers' information for information on the proper operating speeds and types of drills for the material or hole desired.

- A general rule: The larger the hole and the harder the material = the slower the RPM speed.

NOTE: See page 6 for important safety information on drilling set-ups and procedures.

WORKPIECE POSITIONING



WARNING: Always use clamps or hold-downs to secure the material onto the drill press table during drilling. This will prevent the work from being torn from the operator's hand should the drill bit gets caught in the material. Clamping the work to the table is particularly necessary if the table is tilted on an angle.

Place a scrap board or piece of plywood under your work to protect the metal table, drill bit, and to provide a solid base for a clean hole if the drill bit exits the work.

To prevent work from spinning, if possible, position the work to rest against the left side of the column. For shorter pieces, use a clamp or drill press vise secured to the table.

Feed bits into the material at a constant rate to allow the bit to work. Too slowly may cause the wood to burn and ruin the bit. Too fast may put excessive stress on the motor and cause the bit to break.

MAINTENANCE

⚠ WARNING: Turn the power switch “OFF” and disconnect the plug from the outlet prior to adjusting or maintaining the machine. DO NOT attempt to repair or maintain the electrical components of the motor. Contact a qualified service technician for this type of maintenance.

1. Before each use:

- Check the power cord and plug for any wear or damage.
- Check for any loose screws, hardware or parts.
- Check the area to make sure it is clear of any misplaced tools, lumber, cleaning supplies, etc. that could hamper the safe operation of the machine.

2. To avoid a build-up of wood dust, regularly clean all parts of the machine using a soft cloth, brush or compressed air. A general cleaning should be done after every use to avoid future problems and ensure the machine is in ready condition for its next use.

WARNING: If blowing sawdust, wear proper eye protection to prevent debris from blowing into eyes.

3. Keep the machined surfaces of the drill press table and base free of resin and rust. Clean them regularly with a non-flammable solvent, then coat with a light film of dry lubricant spray or wax.

4. Lubricate the table bracket and locking lever bolts to keep them operating smoothly.

5. Clean the column on a regular basis to prevent the build-up of dust, drilling residue and rust. Treat the posts with a dry lubricant spray or a light coating of wax. Do not use ordinary oil which will collect dust and hamper the movement of parts along the column.

6. Periodically, lower the quill assembly and apply a light coating of machine oil to the quill and spindle surfaces. Raise and lower the quill a few times to distribute the oil on all of the internal surfaces.

7. Apply #2 tube grease to the worm gears in the table elevation mechanism and rack to keep them operating smoothly.

8. The ball bearings in the spindle and pulley assemblies are lifetime lubricated, sealed, and do not need any further care.

9. Keep the drive belt and pulley surfaces free of oil and grease. Periodically, check the drive belt for wear and replace if necessary.

WIRING DIAGRAM

⚠ WARNING: This machine must be grounded. Replacement of the power supply cable should only be done by a qualified electrician. See page 5 for additional electrical information.

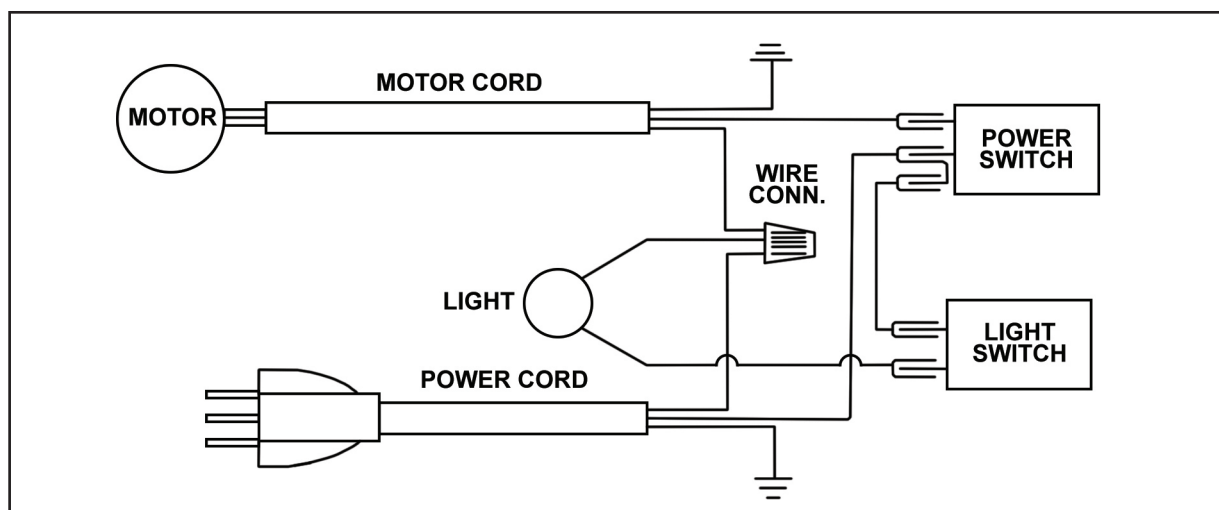

DO NOT attempt to repair or maintain the electrical components of the motor.
Contact a qualified service technician for this type of maintenance.

TROUBLESHOOTING

TROUBLE	PROBABLE CAUSE	REMEDY
Noisy Operation	<ol style="list-style-type: none"> 1. Incorrect belt tension. 2. Dry Spindle. 3. Loose spindle pulley. 4. Loose motor pulley. 	<ol style="list-style-type: none"> 1. Adjust tension. 2. Lubricate spindle. 3. Checking tightness of retaining nut on pulley and tighten if necessary. 4. Tighten set screws in pulleys.
Drill Bit Burns	<ol style="list-style-type: none"> 1. Incorrect speed. 2. Chips not coming out of hole. 3. Dull drill bit. 4. Feeding too slow. 5. Not Lubricated 	<ol style="list-style-type: none"> 1. Change speed. 2. Retract drill bit frequently to clear chips. 3. Resharpen drill bit. 4. Increase the speed. 5. Lubricate drill bit.
Drill bit leads off hole not round.	<ol style="list-style-type: none"> 1. Hard grain in wood or lengths of cutting lips and/ or angles not equal. 2. Bent drill bit. 	<ol style="list-style-type: none"> 1. Resharpen drill bit correctly. 2. Replace drill bit.
Wood splinters on underside.	<ol style="list-style-type: none"> 1. No "back up material" under workpiece. 	<ol style="list-style-type: none"> 1. Use "back-up material"
Wood piece turn loose from hand.	<ol style="list-style-type: none"> 1. Not supported or clamped properly. 	<ol style="list-style-type: none"> 1. Support workpiece or clamp it.
Drill bit binds in workpiece.	<ol style="list-style-type: none"> 1. Workpiece pinching drill bit or excessive feed pressure. 2. Improper belt tension. 	<ol style="list-style-type: none"> 1. Support workpiece or clamp it. 2. Adjust tension.
Excessive drill bit runout or wobble.	<ol style="list-style-type: none"> 1. Bent drill bit. 2. Worn spindle bearings. 3. Drill bit not properly installed in chuck. 4. Chuck not properly installed. 	<ol style="list-style-type: none"> 1. Use a straight drill bit. 2. Replace bearings. 3. Install drill bit properly. 4. Install chuck properly.
Quill Returns too slow or too fast.	<ol style="list-style-type: none"> 1. Spring has improper tension. 	<ol style="list-style-type: none"> 1. Adjust spring tension.
Chuck will not stay attached to spindle, it falls off when trying to install it.	<ol style="list-style-type: none"> 1. Dirty, grease, or oil on the tapered inside surface of chuck or on the spindles tapered surface. 	<ol style="list-style-type: none"> 1. Using a household detergent clean the tapered surface of the chuck and spindle to remove all dirt, grease and oil.

PARTS DIAGRAM

30-240 Drill Press Parts Keyed as A & B

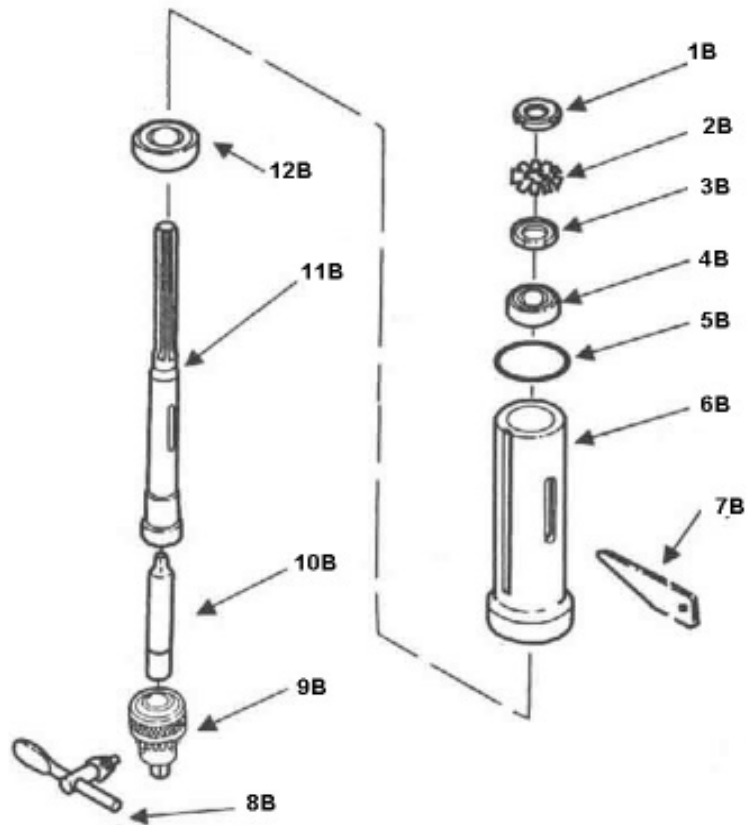
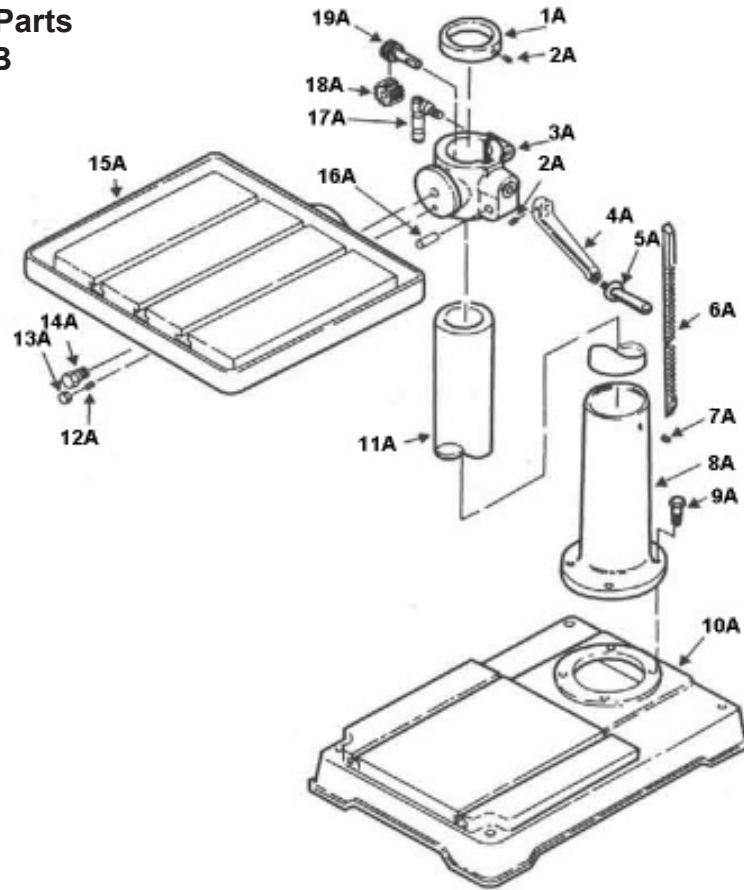

See Page 21 for
the Parts List

PARTS DIAGRAM

30-240 Drill Press Parts
Keyed as C

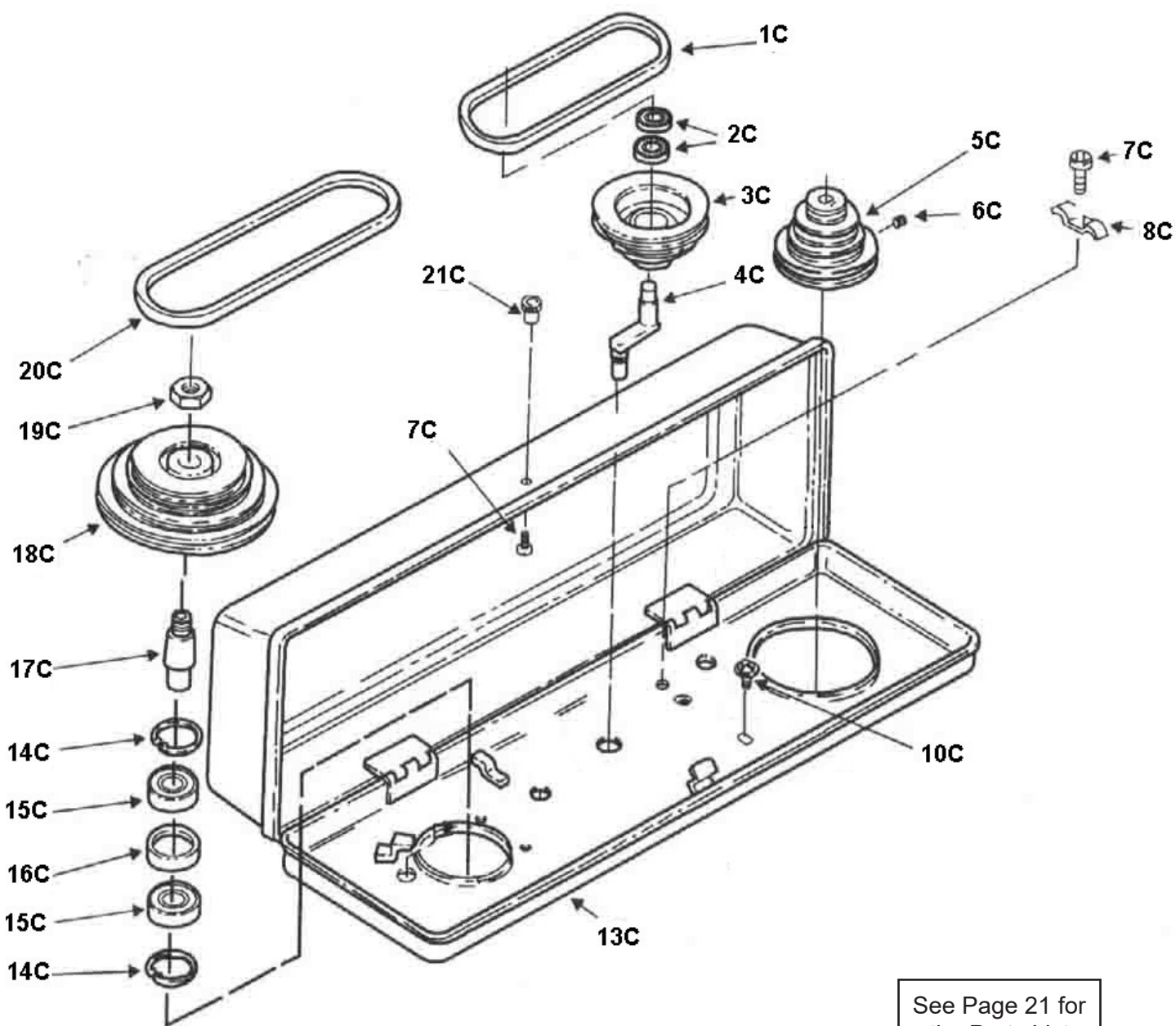

See Page 21 for
the Parts List

NOTE: Please reference the Model Number and Key Number when calling for Replacement Parts.
For Parts under Warranty, the Serial Number of your machine is required.

PARTS DIAGRAM

30-240 Volt Drill Press Parts
Keyed as D

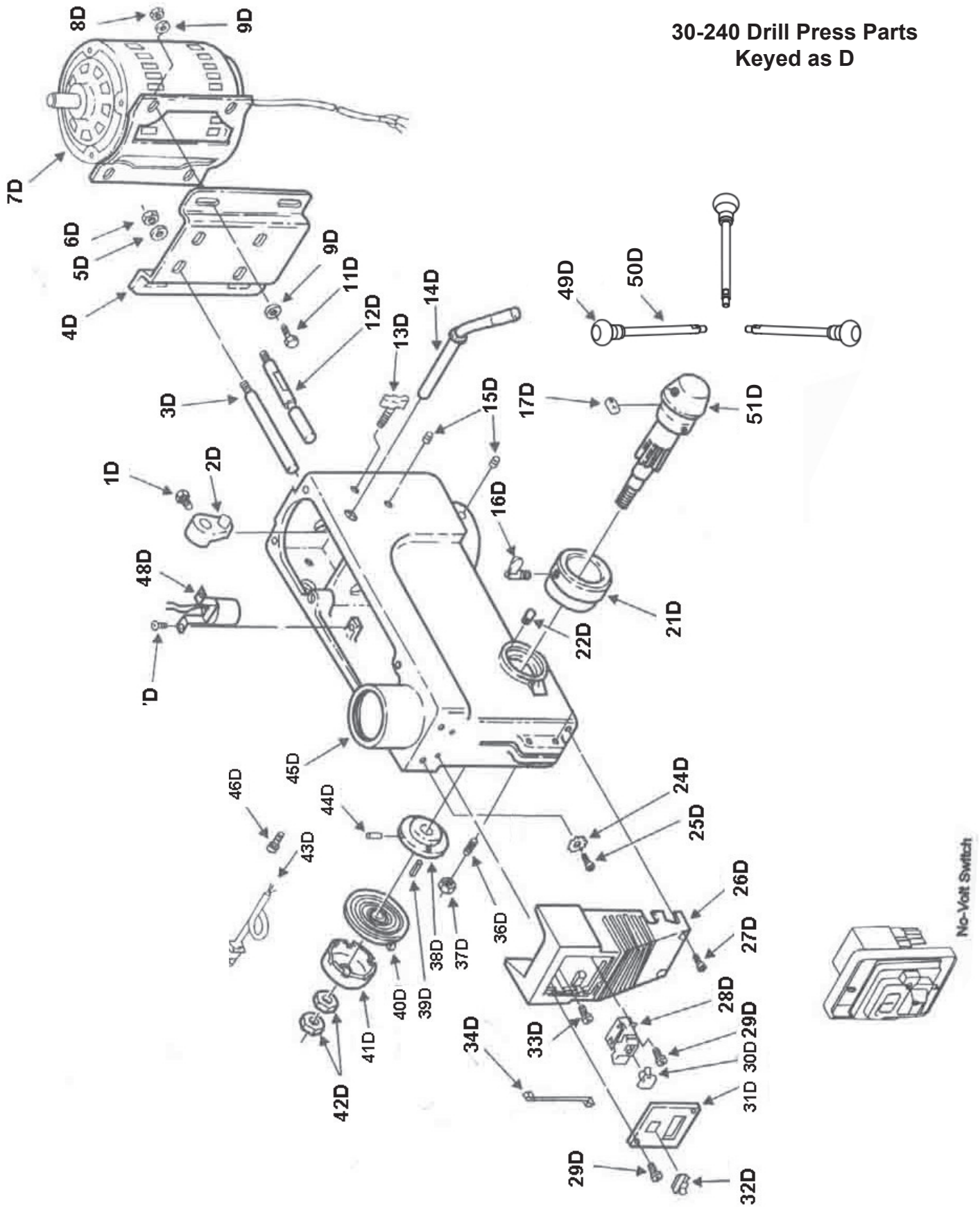

PARTS LIST

KEY NO.	DESCRIPTION	KEY NO.	DESCRIPTION
1A	Collar-Rack	1D	Screw-Hex Head M8x1.25-16
2A	Screw-Hex soc Set M6x1.0-10	2D	Lever-Adjusting
3A	Support-Table with Indicator	3D	Support-Motor Bracket
4A	Crank	4D	Mount-Motor
5A	Handle crank	5D	Lock washer 12mm
6A	Rack	6D	Nut-Hex M12
7A	Screw-Hex Soc Set M10x1.5-12	7D	Motor
8A	Support-Column	8D	Nut-Hex M8x1.25
9A	Screw-Hex Head M12x1.75-40	9D	Washer 8
10A	Base	11D	Screw-Hex Head M8x1.25-20
11A	Tube-Column	12D	Support Motor Bracket
12A	Pin-Table Lock	13D	Knob-Motor Adjusting
13A	Nut-Hex Head M8x1.25	14D	Handle-Belt Tension
14A	Screw-Hex Head M20x2.5-50	15D	Screw-Hex Soc Head M10x1.5-12
15A	Table with Scale	16D	Lock depth screw
16A	Pin-Gear	17D	Guide Scale
17A	Lever Handle-column	21D	Ring-Depth Stop with Scale
18A	Gear-Helical	22D	Pin-Stop
19A	Worm-Elevation	24D	Lock washer-Ext.5
1B	Nut-Lock M20x1.5	25D	Screw-Pan Cr M5x8
2B	Ring-Locking	26D	Box-Switch
3B	Washer	27D	Screw-Pan Cr M5x16
4B	Bearing-Ball 20mm	28D	Switch
5B	Washer-Rubber	29D	Screw-Self Tap Pan Head
6B	Tube-Quill	30D	Safety Key-Switch
7B	Key-Drift	31D	Cover-Switch Plate
8B	Key-Chuck	32D	Switch-Rocker
9B	Chuck	33D	Switch-Pan Cr M6x12
10B	Arbor	34D	Lead Assembly 3
11B	Spindle	36D	Screw-special Set M10x1.5-27
12B	Bearing-Ball 30mm	37D	Nut-Hex M10x1.5
1C	Belt-"V" A29	38D	Seat-Spring
2C	Bearing-Ball 15mm	39D	Pin-roll 6x16
3C	Pulley Center	40D	Spring-Torsion
4C	Pivot-Idler	41D	Cap-Spring
5C	Pulley-motor	42D	Nut-Hex M12-1.5-8
6C	Screw Soc Set M8x1.25-12	43D	Cord-Power
7C	Screw Pan Head M5x0.8-12	44D	Pin-Roll 2.5x10
8C	Clamp-Cord	45D	Head with Pointer & Trim
10C	Screw-Rd Washer Head M6x1.0-12	46D	Connector-Wire
13C	Guard-Pulley w/Labels	47D	Screw-Pan Cr M6x1.0-12
14C	Ring-Retaining	48D	Socket-Bulb
15C	Bearing-Ball 30mm	49D	Handle ball end
16C	Spacer-Bearing	50D	Handle Rods (3)
17C	Insert-Pulley	51D	Hub
18C	Pulley-spindle		
19C	Nut-Pulley		
20C	Belt-"V" A33		
21C	Knob		

NOTE: Please reference the Model Number and Key Number when calling for Replacement Parts. For Parts under Warranty, the Serial Number of your machine is required.

WARRANTY

RIKON

POWER TOOLS®

5-Year Limited Warranty

RIKON Power Tools Inc. ("Seller") warrants to only the original retail consumer/purchaser of our products that each product be free from defects in materials and workmanship for a period of five (5) years from the date the product was purchased at retail. This warranty may not be transferred.

This warranty does not apply to defects due directly or indirectly to misuse, abuse, negligence, accidents, repairs, alterations, lack of maintenance or normal wear and tear. Under no circumstances will Seller be liable for incidental or consequential damages resulting from defective products. All other warranties, expressed or implied, whether of merchantability, fitness for purpose, or otherwise are expressly disclaimed by Seller. This five-year warranty does not cover products used for commercial, industrial or educational purposes. The warranty term for these claims will be limited to a two-year period.

This limited warranty does not apply to accessory items such as blades, drill bits, sanding discs, grinding wheels, belts, guide bearings and other related items.

Seller shall in no event be liable for death, injuries to persons or property, or for incidental, contingent, special, or consequential damages arising from the use of our products.

To take advantage of this warranty, proof of purchase documentation must be provided which has the date of purchase and an explanation of the complaint.

The Seller reserves the right to effect at any time, without prior notice, those alterations to parts, fittings, and accessory equipment which they may deem necessary for any reason whatsoever.

To register your machine online, visit RIKON at www.rikontools.com/warranty

To take advantage of this warranty, or if you have any questions, please contact us at 877-884-5167 or email warranty@rikontools.com



**For more information:
16 Progress Road
Billerica, MA 01821**

**877-884-5167 / 978-528-5380
techsupport@rikontools.com**

LINK TO RIKON WEBSITE

