

Elegant Beauty Rollerball & Fountain Pen Kits



From Setup To Sanding:

These are the supplies we suggest you have on hand to complete this pen kit:

- $\frac{27}{64}$ " Pen Maker's Bit Upper Blank
- Letter "V" Pen Maker's Bit Lower Blank
- $\frac{3}{4}$ " x $\frac{3}{4}$ " x $1\frac{5}{8}$ " Upper Blank
- $\frac{3}{4}$ " x $\frac{3}{4}$ " x $2\frac{1}{2}$ " Lower Blank
- Pen Mandrel
- Elegant Beauty RB & FP Bushings (180436)
- Thick CA or 5 Minute Epoxy
- Drill or Drill Press
- Sandpaper/MicroMesh
- Pen Mill Pilot Shaft $\frac{27}{64}$ " & "V"
- Pen Press
- Eye & Ear Protection
- Dust Mask

Cutting & Drilling Blanks:

Note: Additional length has been added to the overall length of the blank to accommodate for squaring the ends of the blank.

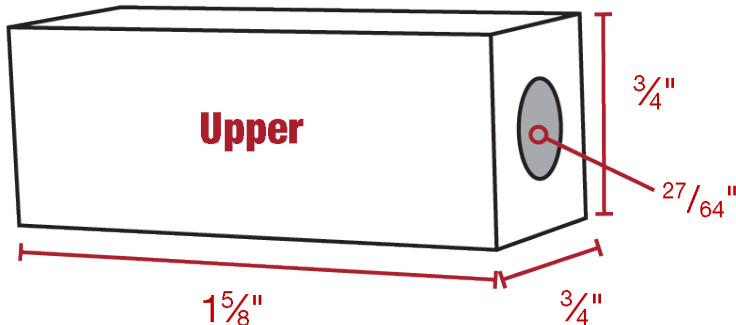
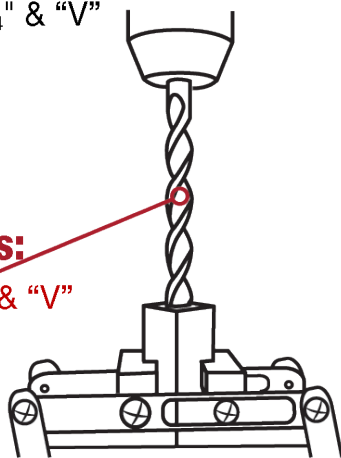

Product: #180427, #180428, #180429, #180430, #180431, #180432, #180433, #180434 4/26/2022

Gluing Blanks to Tubes:

Rough the entire surface of the tube using 180 grit paper. Next, using either a thick CA or 5 Minute Epoxy, apply adhesive to both the tube and the inside of the blank. To secure the brass tube into the inside of the blank make sure to rotate the tube as you insert it into the blank. This will help ensure even coverage of the adhesive and a much more secure bond.

Squaring the Blank to Length:

When squaring the blanks to length ensure to only go to the brass. Removing brass will affect the overall length of the blank which is critical to the proper operation of the pen.

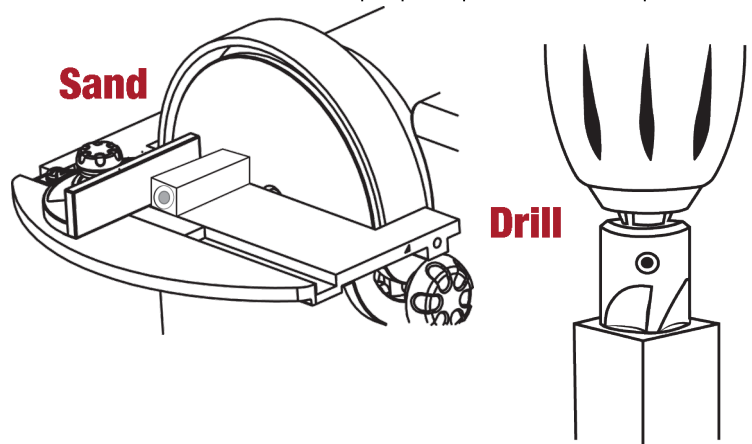

Mandrel Preparation:

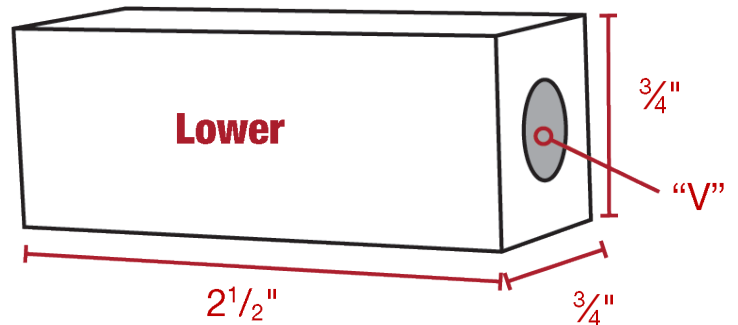

Elegant Beauty Rollerball & Fountain Pen Kits

Product: #180427, #180428, #180429, #180430, #180431, #180432, #180433, #180434

4/26/2022

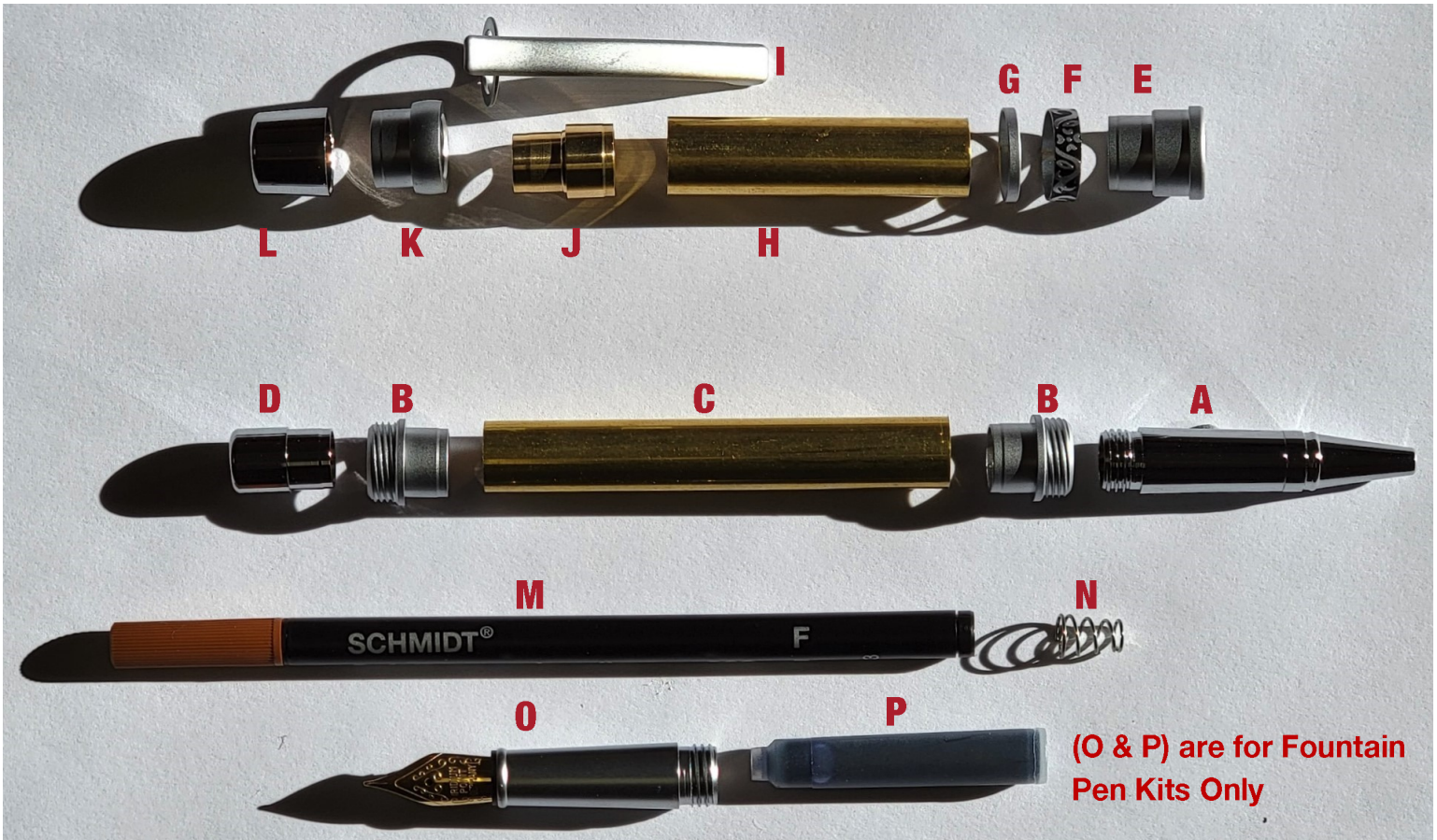

Turning & Finishing the Blanks:

Turn the blanks to your desired profile leaving them slightly proud of the bushings. With the lathe spinning, begin sanding with 120 grit paper progressing through the finer grits finishing at 320 grit. Once finished with sanding apply a finish of your choice.

Rollerball & Fountain Pen Cap Assembly:

- ❑ Press Cap (L) onto Clip Band (K). Slide Clip (I) onto Clip Coupler (J) small end and press into Clip Assembly (L & K). Press Cap Assembly (L, K, I, & J) into the .470" end of the Finished Upper Blank (H).
- ❑ Slide Center Band Accent (F) followed by (G) onto small end of Center Band Coupling (E). Press assembly into .485" end of Finished Upper Blank (H). Set cap assembly aside.

Rollerball & Fountain Pen Body:

- ❑ Press Threaded Couplings (B) into each end of the Finished Lower Blank (C).
- ❑ Press Finial (D) into one end of the Finished Lower Blank (C).
- ❑ Slide Spring (N) large end first into the open end of the Finished Lower Blank (C), remove protective cap from Ink Refill (M) and install. Finish installation by threading Nib (A) into Finished Lower Blank (C).
- ❑ For Fountain Pen Kits follow steps 1 & 2. Install Ink Cartridge (P) into end of Fountain Pen Nib (O) and thread into the open end of the Finished Lower Blank (C).