

Cigar Pen Kits

Product #: #147155, #147156, #147157, #148459, #148460, #148749, #148779, #149248, #149767, #150866, #150867, #152607, #153085, #828439, #165909, #165910, #176313, #176314 #176315 5/13/202



From Setup To Sanding:

These are the supplies we suggest you have on hand to complete this pen kit:

- 10mm Pen Maker's Bit
- 1 - $\frac{3}{4}$ " x $\frac{3}{4}$ " x $2\frac{1}{16}$ " Cap Blank
- 1 - $\frac{3}{4}$ " x $\frac{3}{4}$ " x $2\frac{1}{4}$ " Body Blank
- Pen Mandrel
- Cigar Bushings (147161)
- Thick CA or 5 Minute Epoxy
- Drill or Drill Press
- Sandpaper/MicroMesh
- Barrel Trimmer
- Pen Press
- Eye & Ear Protection
- Dust Mask

Cutting & Drilling Blanks:

Note: Additional length has been added to the overall length of the blank to accommodate for squaring the ends of the blank.

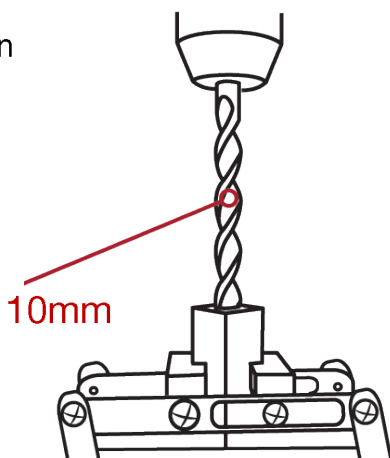

Rough the entire surface of the tube using 180 grit paper. Next, using either a thick CA or 5 Minute Epoxy, apply adhesive to both the tube and the inside of the blank. To secure the brass tube into the inside of the blank make sure to rotate the tube as you insert it into the blank. This will help ensure even coverage of the adhesive and a much more secure bond.

Squaring the Blank to Length:

When squaring the blanks to length ensure to only go to the brass. Removing brass will affect the overall length of the blank which is critical to the proper operation of the pen.

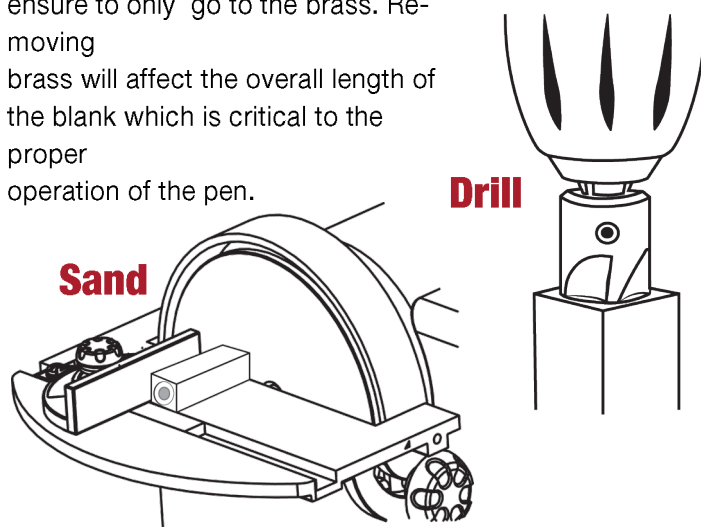

Mandrel Preparation:



Gluing Blanks to Tubes:

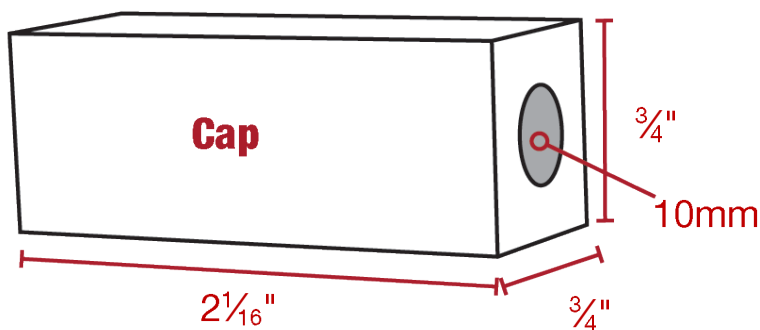
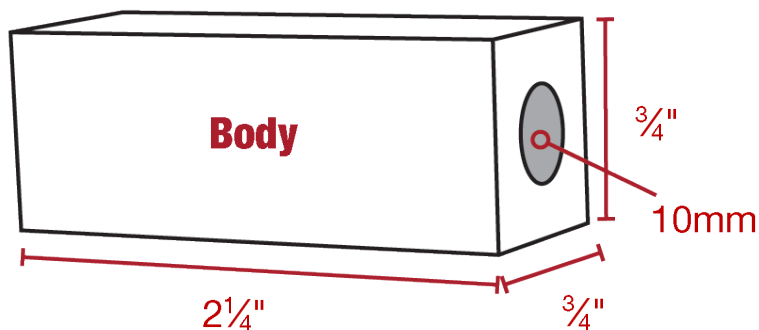

Cigar Pen Kits

Product #: #147155, #147156, #147157, #148459, #148460, #148749, #148779, #149248, #149767, #150866, #150867, #152607, #153085, #828439, #165909, #165910, #176313, #176314 #176315

5/13/2021

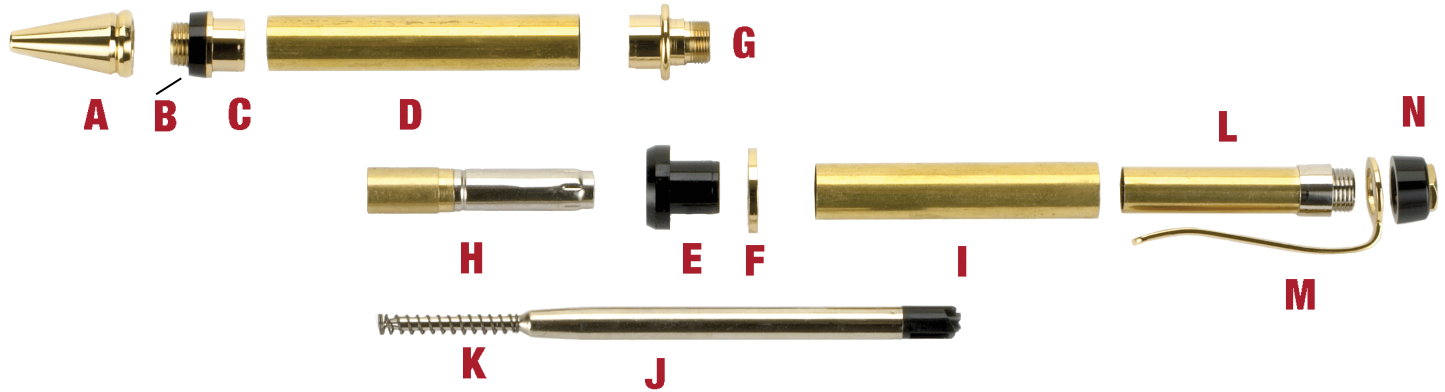

Turning & Finishing the Blanks:

Turn the blank to your desired profile leaving the blank slightly proud of the bushings. With the lathe spinning, begin sanding with 120 grit paper progressing through the finer grits finishing at 320 grit. Once finished with sanding apply a finish of your choice.

Pen Assembly:

Cap:

- ❑ Slide Decorative Ring (F) onto Black Center Band (E) and press into the larger diameter end of the Cap/Tube Assembly (I).
- ❑ Next press the Clip Connector (L) into the small end of the Cap/Tube Assembly until the shoulder is flush with the wood ensuring to leave the threads exposed.
- ❑ Slide Clip (M) over the threaded portion and finish by threading and tightening the Finial Cap (N) onto the Cap/Tube Assembly.

Body:

- ❑ Thread the Decorative Ring (B) onto the Nib Adapter (C) ensuring that the taper of the Ring matches the taper of the Nib.

- ❑ Next thread the Nib (A) onto the Adapter and press into the smallest end of the Body/Tube Assembly (D).
- ❑ Next press the Twist Holder (G) into the open end of the Body/Tube Assembly followed by inserting the Ink Refill Assembly (K, J).
- ❑ Next thread Twist Mechanism (H) onto the Twist Holder (G).
- ❑ Press the assembled Cap and Body together by hand.

To advance the ink refill hold the body and turn the cap clockwise, to retract the ink refill turn the cap counter clockwise.