

Cushion Grip Click Pen Kit

Product : #144636

8/28/2015



From Setup To Sanding:

These are the supplies we suggest you have on hand to complete this pen kit:

- Letter "O" Pen Maker's Bit
- 3/4" x 3/4" x 2 1/4" Pen Blank
- Pen Mandrel
- Cushion Grip Click Pen Bushings (144638)
- Thick CA or 5-Minute Epoxy
- Drill or Drill Press
- Sandpaper/Micro-Mesh
- Barrel Trimmer
- Pen Press
- Eye & Ear Protection
- Dust Mask

Cutting & Drilling Blanks:

Note: Additional length has been added to the overall length of the blank to accommodate for squaring the ends of the blank.

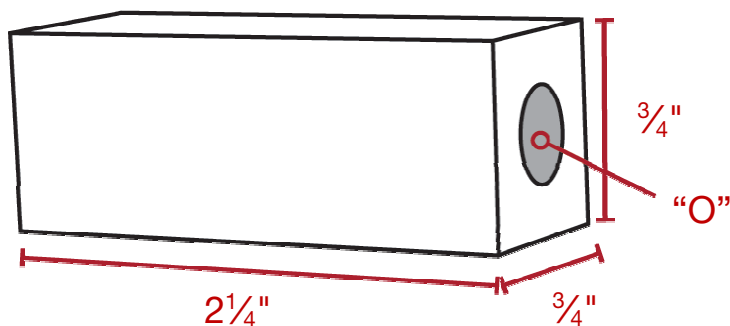
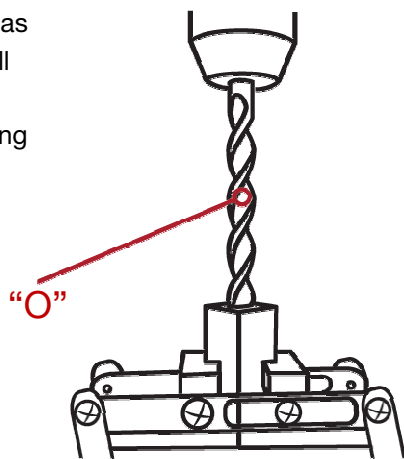

Gluing Blanks to Tubes:

Rough the entire surface of the tube using 180-grit paper. Next, using either a thick CA or 5-Minute Epoxy, apply adhesive to both the tube and the inside of the blank. To secure the brass tube into the inside of the blank make sure to rotate the tube as you insert it into the blank. This will help ensure even coverage of the adhesive and a much more secure bond.

Squaring the Blank to Length:

When squaring the blanks to length, work only to the brass. Removing brass will affect the overall length of the blank which is critical to the proper operation of the pen.

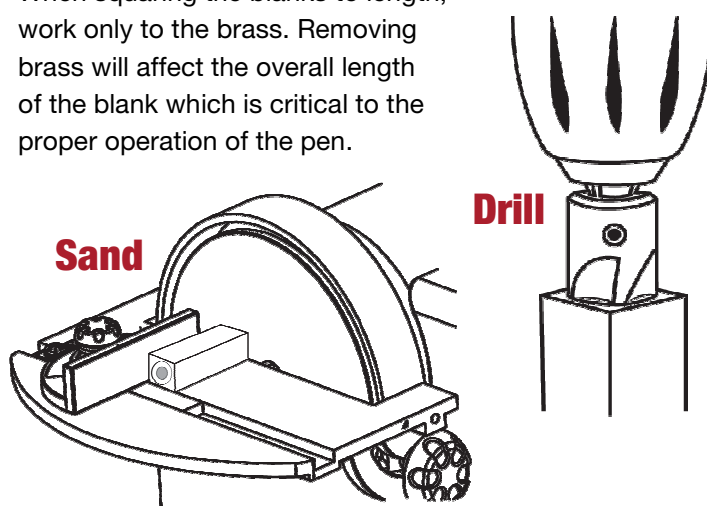

Mandrel Preparation:

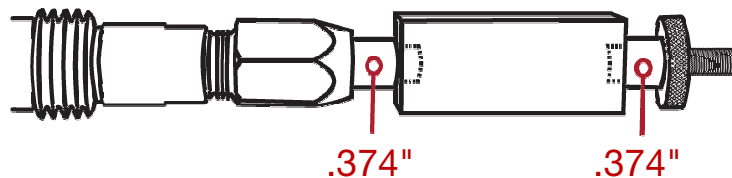

Turning & Finishing the Blanks:

Turn the blank to your desired profile, leaving the blank slightly proud of the bushings. With the lathe spinning, begin sanding with 120-grit paper, and progress through the finer grits finishing at 320-grit. Once finished with sanding apply a finish of your choice.

Cushion Grip Click Pen Kit

Product : #144636

8/28/2015

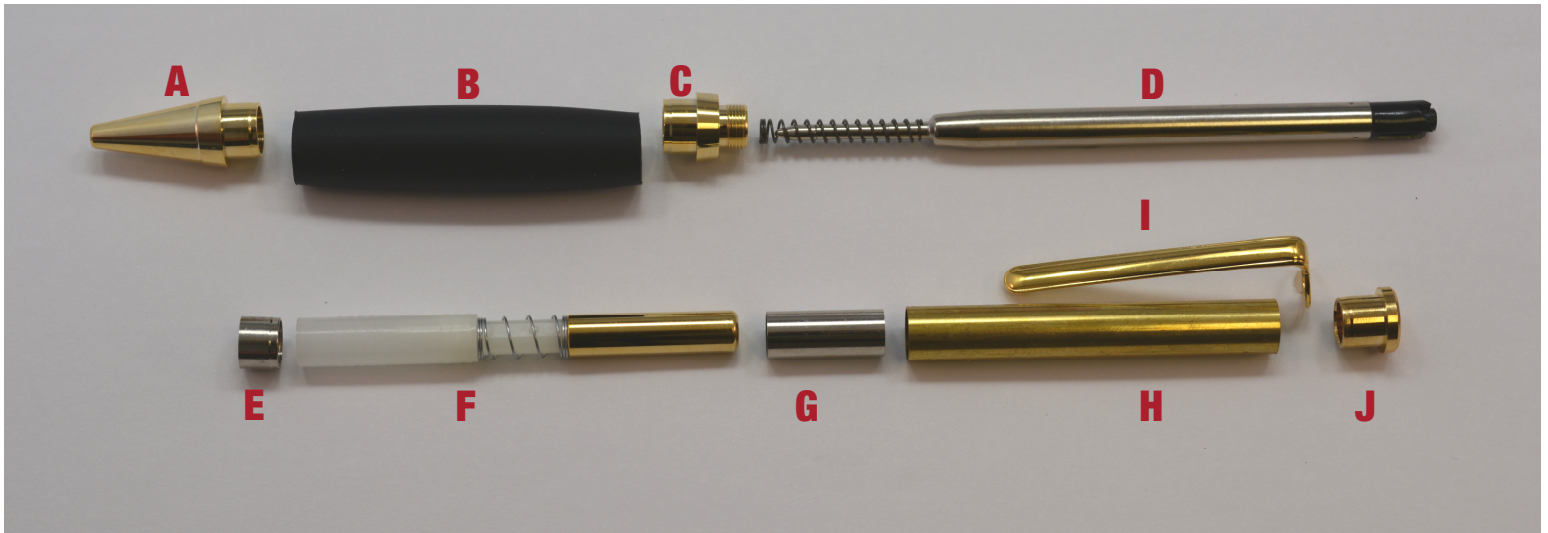

Pen Assembly:

Lower Barrel:

- ❑ Press Nib (A) into one end of the Cushion Grip Barrel (B).
- ❑ Press the Center Connector (C) non threaded end into the opposite end of the Cushion Grip Barrel (B).

Upper Barrel:

- ❑ Slide the Clip Retainer (J) into the opening of the Clip (I) and press into one end of the finished Upper Barrel (H).
- ❑ Next slide the small Chrome Sleeve (G) over the top of the Click Mechanism (F) until it covers the spring of the Click Mechanism (F).
- ❑ Slide the Click Mechanism (F) gold top first into the open end of the finished Upper Barrel (H). Using the black end of the Ink Refill (D) push the Click Mechanism up through to the top of the Clip Retainer (J) until it stops.
- ❑ Using a scrap piece of $\frac{3}{4}$ " thick wood, bore a 6 mm hole completely through the $\frac{3}{4}$ " thickness. This press block will be critical for the following steps. Failure to use the press block will lead to damaging the Click Mechanism.
- ❑ Using the press block, insert the Click Mechanism (F) into the 6 mm hole. Press the Threaded Sleeve (E) lip end first into the open end of the finished Upper Barrel (H) until the sleeve

is flush with the bottom of the barrel.

- ❑ Insert the Ink Refill/Spring Assembly (D) into the Cushion Grip Barrel (B).
- ❑ Complete the assembly by threading the finished Upper Barrel onto the Cushion Grip Barrel.