



Operating Instructions and Parts Manual

16" x 40" Woodturning Lathe

Model JWL-1640EVS



Shown with optional guard # 719002

JET
427 New Sanford Road
LaVergne, Tennessee 37086
Ph.: 800-274-6848
www.jettools.com

Part No. M-719500
Edition 2 12/2018
ECR 181010091219
Copyright © 2016 JET



1.0 IMPORTANT SAFETY INSTRUCTIONS

WARNING – To reduce risk of injury:

1. Read and understand the entire owner's manual before attempting assembly or operation.
2. Read and understand the warnings posted on the machine and in this manual. Failure to comply with all of these warnings may cause serious injury.
3. Replace warning labels if they become obscured or removed.
4. This wood lathe is designed and intended for use by properly trained and experienced personnel only. If you are not familiar with the proper and safe operation of a wood lathe, do not use it until the proper training and knowledge have been obtained.
5. Do not use this lathe for other than its intended use. If used for other purposes, JET disclaims any real or implied warranty and holds itself harmless from any injury that may result from that use.
6. Always wear ANSI Z87.1 approved safety glasses or face shield while using this drum sander. (Everyday eyeglasses only have impact resistant lenses; they are *not* safety glasses.)
7. Make certain the machine is properly grounded.
8. Before operating the machine, remove tie, rings, watches, other jewelry, and roll sleeves up past the elbows. Remove all loose clothing and confine long hair. Do **not** wear gloves.
9. Keep the floor around the machine clean and free of scrap material, oil and grease.
10. Keep machine guards in place at all times when the machine is in use. If removed for maintenance purposes, use extreme caution and replace the guards immediately.
11. Do **not** over reach. Maintain a balanced stance at all times, so that you do not fall or lean against rotating parts.
12. Make all machine adjustments or maintenance with the machine unplugged from the power source.
13. Use the right tool. Do not force a tool or attachment to do a job that it was not designed to do.
14. Make certain the switch is in the **OFF** position before connecting the machine to the power supply.
15. Give your work undivided attention. Looking around, carrying on a conversation and "horse-play" are careless acts that can result in serious injury.
16. Keep visitors a safe distance from the work area. Keep children away.
17. Make your workshop child proof with padlocks, master switches or by removing starter keys.
18. Maintain a balanced stance at all times so that you do not fall onto moving parts. Do not overreach or use excessive force to perform any machine operation.
19. Use recommended accessories; improper accessories may be hazardous.
20. Do not operate this lathe while under the influence of drugs, alcohol or any medication.
21. Keep tools sharp and clean for safe and best performance. Dull tools can grab in the workpiece and be jerked from the operator's hands, causing serious injury.
22. Check the condition of the stock to be turned. Make sure it is free of knots, warpage, checked ends, improperly made or cured glue joints and other conditions which can cause it to be thrown out of the lathe.
23. Securely fasten spur and live centers to the material being used.
24. Check centers and tapers in the headstock and tailstock to be sure they are free of dirt or rust, and oil lightly before inserting centers.
25. Test each set-up by revolving the workpiece by hand to ensure it clears the tool rest and bed. Check the setup at the lowest speed before increasing to operating speed.
26. Use the correct cutting tool for the operation to be performed and keep all tools sharp.
27. Use low speeds for roughing and for long or large diameter work. If vibration occurs, stop the machine and correct the cause.
28. When sanding, remove the tool rest from the machine, apply light pressure and use a slow speed to avoid heat buildup.
29. When turning large diameter pieces, such as bowls, always operate the lathe at low speeds. See speed recommendation chart in *sect. 12.0*.
30. Do not attempt to engage the spindle lock pin until the spindle has stopped. If leaving the machine area, turn lathe off and wait until the spindle stops rotating before departing.

31. Make no adjustments except speed changes with the spindle rotating, and always disconnect the machine from the power source when performing maintenance to avoid accidental starting or electrical shock.
32. Provide for adequate space surrounding work area and non-glare, overhead lighting.
33. When stopping the lathe, never grab the workpiece or faceplate to slow it down. Let the work coast to a stop.
34. Use only JET factory authorized replacement parts and accessories; otherwise, the warranty and guarantee are null and void.
35. Use proper extension cord. Make sure your extension cord is in good condition. When using an extension cord, be sure to use one heavy enough to carry the current your product will draw. An undersized cord will cause a drop in line voltage resulting in loss of power and overheating. Table 1 (sect. 6.3) shows correct size to use depending on cord length and nameplate ampere rating. If in doubt, use the next heavier gage. The smaller the gage number, the heavier the cord.

⚠ WARNING: This product can expose you to chemicals including lead and cadmium which are known to the State of California to cause cancer and birth defects or other reproductive harm, and phthalates which are known to the State of California to cause birth defects or other reproductive harm. For more information go to <http://www.p65warnings.ca.gov>.

⚠ WARNING: Drilling, sawing, sanding or machining wood products generates wood dust and other substances known to the State of California to cause cancer. Avoid inhaling dust generated from wood products or use a dust mask or other safeguards for personal protection.

Wood products emit chemicals known to the State of California to cause birth defects or other reproductive harm. For more information go to <http://www.p65warnings.ca.gov/wood>.

Familiarize yourself with the following safety notices used in this manual:

⚠ CAUTION

This means that if precautions are not heeded, it may result in minor injury and/or possible machine damage.

⚠ WARNING

This means that if precautions are not heeded, it may result in serious, or possibly even fatal, injury.

SAVE THESE INSTRUCTIONS

2.0 About this manual

This manual is provided by JET, covering the safe operation and maintenance procedures for a JET Model JWL-1640EVS Woodturning Lathe. This manual contains instructions on installation, safety precautions, general operating procedures, maintenance instructions and parts breakdown. Your machine has been designed and constructed to provide consistent, long-term operation if used in accordance with the instructions as set forth in this document.

This manual is not intended to be an exhaustive guide to lathe operational methods, use of after-market accessories, choice of stock, and such. Additional knowledge may be obtained from experienced users or trade articles. Whatever accepted methods are used, always make personal safety a priority.

If there are questions or comments, please contact your local supplier or JET. JET can also be reached at our web site: www.jettools.com.

Retain this manual for future reference. If the machine transfers ownership, the manual should accompany it.

⚠ WARNING

Read and understand the entire contents of this manual before attempting assembly or operation! Failure to comply may cause serious injury!

3.0 Table of contents

Section	Page
1.0 IMPORTANT SAFETY INSTRUCTIONS	2
2.0 About this manual	3
3.0 Table of contents	4
4.0 Specifications	5
5.0 Setup and assembly.....	7
5.1 Shipping contents.....	7
5.2 Tools required for assembly.....	7
5.3 Unpacking and cleanup.....	7
5.4 Installing leg set.....	7
5.5 Tool shelf.....	8
5.6 Guard (optional accessory).....	8
5.7 Bed extension (optional accessory)	8
6.0 Electrical connections	9
6.1 GROUNDING INSTRUCTIONS	9
6.2 115V operation	9
6.3 Extension cords.....	10
7.0 Adjustments	10
7.1 Headstock movement.....	10
7.2 Tailstock movement	10
7.3 Removing items from bed	10
7.4 Cam tightness	10
7.5 Tool rest	11
7.6 Tool rest extension	11
7.7 Locking handles	11
7.8 Spindle indexing.....	11
7.9 Spur center: Installing/removing.....	12
7.10 Live center: Installing/removing.....	12
7.11 Live center and cone	12
7.12 Spindle lock.....	12
7.13 Face plate: Installing/removing.....	13
7.14 Checking center alignment.....	13
7.15 Speed Change	13
8.0 Operating controls.....	14
9.0 Operation	15
9.1 Inspection.....	15
9.2 Turning Tools	15
9.3 Spindle Turning	15
9.4 Stock Selection.....	16
9.5 Cutting Techniques	17
9.6 Face Plate and Bowl Turning	18
9.7 Bowl Turning Techniques.....	19
10.0 Maintenance.....	21
10.1 General procedures.....	21
10.2 Pulley and belt alignment	21
10.3 Pulley and belt replacement.....	21
11.0 Troubleshooting JWL-1640EVS Lathe.....	22
12.0 Recommended Lathe Speeds (per diameter of workpiece).....	23
13.0 Optional accessories.....	23
14.0 Replacement Parts.....	23
14.1.1 JWL-1640EVS Headstock Assembly – Exploded View	24
14.1.2 JWL-1640EVS Headstock Assembly – Parts List	25
14.2.1 JWL-1640EVS Controller Assembly – Exploded View	27
14.2.2 JWL-1640EVS Controller Assembly – Parts List.....	27
14.3.1 JWL-1640EVS Bed and Stand Assemblies – Exploded View.....	28
14.3.2 JWL-1640EVS Bed and Stand Assembly – Parts List	29
14.4.1 JWL-1640EVS Extension Bed Assembly (OPTIONAL) – Exploded View.....	30
14.4.2 JWL-1640EVS Extension Bed Assembly (OPTIONAL) – Parts List	30
14.5.1 JWL-1640EVS Guard Assembly (OPTIONAL) – Exploded View.....	31
14.5.2 JWL-1640EVS Guard Assembly (OPTIONAL) – Parts List.....	31
15.0 Electrical Connections for JWL-1640EVS.....	32
16.0 Warranty and Service.....	33

4.0 Specifications

Model number JWL-1640EVS
 Stock number 719500

Motor and electricals:

Motor type totally enclosed fan cooled, induction
 Horsepower 1.5HP (1.1 kW)
 Phase 3
 Voltage 230 V
 Cycle 60Hz
 Listed FLA (full load amps) 4.6 A
 Starting amps 5.8 A
 Running amps (no load) 3 A
 Power transfer V-belt
 Drive electronic variable speed, inverter control
 On/off switch paddle switch with removable safety key
 Motor speed 1720 RPM
 Power cord SJT 3x14AWG (300V)
 Power cord length 6 ft. (183cm)
 Power plug installed 5-15P UL
 Power input requirements **single phase, 115V only**
 Recommended circuit size¹ 15 A
 Noise emission without load² 78 dB at 20 inches from motor

Capacities:

Working distance between centers 39 in. (990 mm) with single bearing center
 Working distance between centers 37 in. (940 mm) with live cone center
 Working distance between centers, optional 20" bed ext. mounted 59 in. (1543 mm) single bearing center
 Working distance between centers, optional 20" bed ext. mounted 57 in. (1447 mm) with live cone center
 Maximum distance between spindle face and tailstock quill, optional 20" bed ext. mounted 60-1/2 in. (1536 mm)
 Swing over bed 16.5 in. (419 mm)
 Swing over tool rest base 12-7/8 in. (327 mm)
 Indexing 36 positions, positive locking, 10 degree increments
 Swing over 20" bed extension in low position (*optional accessory*) 34-1/2 in. (876 mm)

Headstock and Spindle:

Spindle taper MT-2
 Spindle thread, inboard 1-1/4 in. x 8 TPI
 Spindle thread, outboard 3/4"-16 (LH)
 Spindle speed (RPM) variable within 40-1200 (low) and 100-3200 (high)
 Headstock spindle bore 3/8 in. (10 mm)
 Spindle direction forward and reverse
 Headstock movement sliding

Tailstock:

Tailstock quill taper MT-2
 Tailstock bore 5/16 in. (9 mm)
 Tailstock quill travel 4-1/4 in. (108 mm)
 Tailstock quill thread acme, 3/4"-10 (LH)

Materials:

Legs cast iron
 Bed cast iron
 Headstock cast iron
 Headstock spindle steel
 Tailstock cast iron
 Tailstock quill hardened HRC20 steel, with laser etched scale
 Tool support and base cast iron

¹ subject to local/national electrical codes

² The specified values are emission levels and are not necessarily to be seen as safe operating levels. As workplace conditions vary, this information is intended to allow the user to make a better estimation of the hazards and risks involved only.

Weights:

Net weight (approx.)	375 lbs
Shipping weight (approx.)	440 lbs

Dimensions:

Tool rest.....	14 in. (356 mm)
Leg footprint.....	54 x 20 in. (1372 x 508 mm)
Bed length.....	53 in. (1346 mm)
Bed width.....	7-1/8 in. (181 mm)
Bed gap	1-3/4 in. (44.5 mm)
Overall height, floor to top of headstock, without levelers.....	48-1/4 in. (1226 mm)
Distance floor to spindle centerline (approximate).....	45 in. (1143 mm)
Tool rest post diameter	1 in. (25.4 mm)
Shipping dimensions (LxWxH).....	57 x 31 x 28 in. (1448 x 788 x 711 mm)
Overall dimensions, assembled (LxWxH).....	73 x 52-1/2 x 20 in. (1854 x 1334 x 508 mm)
Bed Extension length (<i>optional accessory</i>).....	20 in. (508 mm)

L= length; W=width; H=height

The specifications in this manual were current at time of publication, but because of our policy of continuous improvement, JET reserves the right to change specifications at any time and without prior notice, without incurring obligations.

5.0 Setup and assembly

⚠WARNING The Lathe must be disconnected from power during assembly.

5.1 Shipping contents

Carton contents (see Figure 5-1)

- 1 Lathe bed with headstock, tool support and tailstock – **A**
- 1 Tool rest – **B**
- 2 Legs – **C**
- 1 Spur center – **D**
- 1 Live center – **E**
- 1 Live cone center – **F**
- 1 Live cone center pin – **G**
- 1 Knockout rod – **H**
- 1 Faceplate – **J** (installed on lathe)
- 1 Faceplate wrench – **L**
- 4 Levelers – **M**
- 1 Tool shelf – **N**
- 1 Operating Instructions & Parts Manual
- 1 Warranty Card

Hardware:

- 8 Socket hd. cap screws, 5/16x1-1/4 – **HP1***
- 8 Lock washers, 5/16 – **HP2***
- 8 Flat washers, 5/16 – **HP3***
- 2 Socket hd. cap screws, 3/8x1-1/4 – **HP4**
- 2 Lock washers, 3/8 – **HP5**

* included in JWL1440-HP1, hardware package

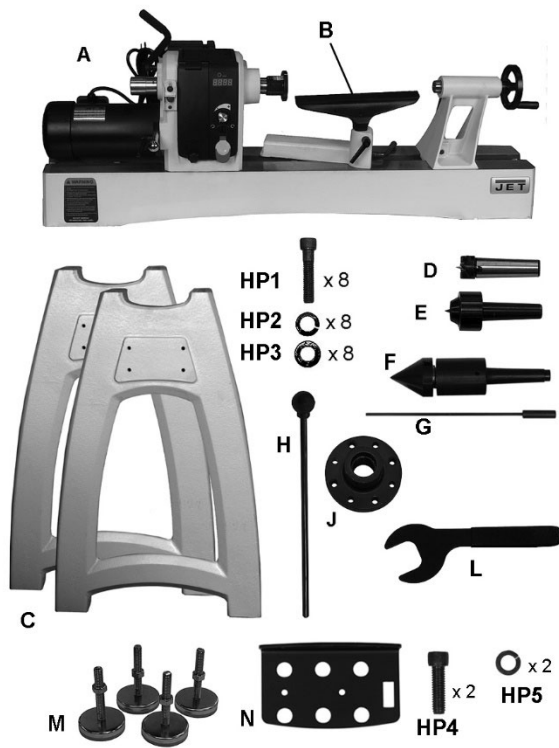

Figure 5-1: shipping contents (not to scale)

5.2 Tools required for assembly

Hex keys, 6mm, 8mm
Open end wrench, 14mm

5.3 Unpacking and cleanup

1. Remove all smaller items from main carton. Do not discard carton or packing material until lathe is assembled and running satisfactorily.
2. Inspect contents for shipping damage; if any is found, report it to your distributor.
3. Compare contents of shipping carton with the contents list in this manual. Report shortages, if any, to your distributor. **Note:** Check lathe first – some parts may have been pre-installed.
4. Exposed metal areas of the Lathe, such as bedways and spindles, have been factory coated with a protectant. This should be removed with a soft cloth and a cleaner-degreaser. Clean the bed areas under headstock, tailstock and tool support base. Do not use an abrasive pad, and do not allow solvents to contact painted or plastic areas.

5.4 Installing leg set

See Figures 5-2 and 5-3.

1. Install levelers into bottom of legs (Figure 5-2) and tighten hex nut against leg casting. The levelers can be adjusted later.



Figure 5-2: installing leveler

⚠WARNING Lathe is heavy – use caution during leg installment procedures. Use straps in good condition. Straps/lifting mechanisms must be properly rated for lathe weight.

5.4.1 Hoist lifting method

1. Position straps around lathe bed. **IMPORTANT:** Do *not* place straps around spindle, near levers, knobs or other parts that can be damaged when lifting.
2. Position lathe onto legs and secure with screws and washers (HP1/2/3, Figure 5-3) using 6mm hex key.
3. Tighten screws firmly.

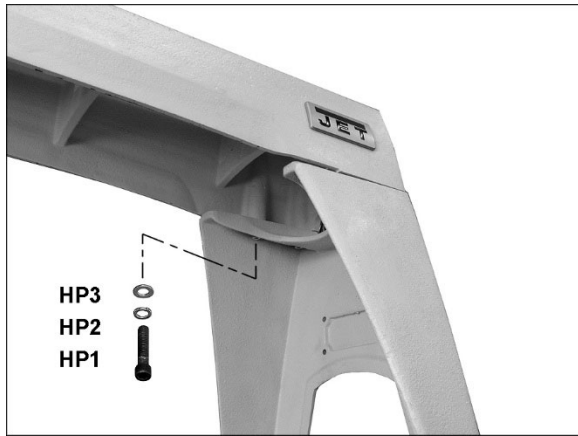

Figure 5-3: installing legs

5.4.2 Manual lifting method

CAUTION Use help from an assistant for the following procedures.

1. Unscrew stud (see O, Figure 5-6) from each end of bed. (Note: studs can be stored in one of the threaded holes in lathe legs.)
2. Remove headstock, tailstock and tool rest support from bed. (Refer to sect. 7.0 for detailed instructions on adjusting and removing these items.)
3. Carefully turn bed upside down. Place a mat or cardboard beneath it to prevent scratching the bed ways.
4. Install legs with screws and washers (HP1/2/3, Figure 5-3) using 6mm hex key.
5. Tighten screws firmly.
6. Raise bed and leg assembly right-side up.
7. Rotate levelers (Figure 5-2) as needed to establish level for the lathe. Tighten hex nut on each leveler against leg casting.
8. Install headstock, tool support and tailstock, and both studs (O, Figure 5-6).

5.5 Tool shelf

The tool shelf (N) can be mounted to either end of lathe with screws and washers (HP4/5).

5.6 Guard (optional accessory)

4mm hex key required.

The guard (part no. 719002) is optional and purchased separately. See our website for information.

1. Loosen set screw on outer collar (shown in Figure 5-4) with 4mm hex key. Slide outer collar off the guard support rod.
2. Insert guard support rod into mounting bracket at rear of headstock. You will have to lift up on spring pin, as shown, to slide guard support

rod into mounting bracket. Release spring pin and it will snap into position as you slide support rod farther in.

3. Install outer collar and tighten set screw.
4. The guard can be pivoted to one of two positions: Operating mode (shown on front cover) or tilted back for stock loading (Figure 5-5).
5. Pull up on spring pin, and begin tilting guard, then release spring pin. When guard reaches either of the two positions, spring pin will engage.

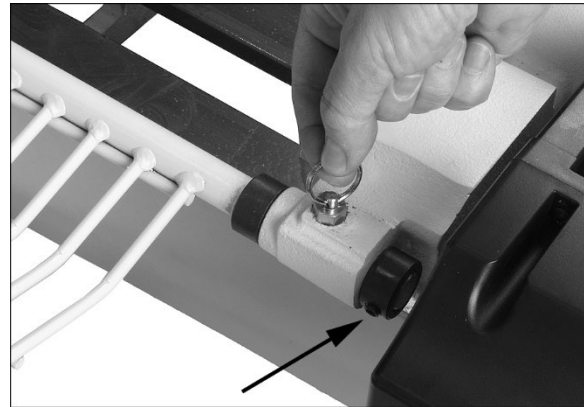

Figure 5-4: installing guard (optional)



Figure 5-5: guard (optional) tilted back

5.7 Bed extension (optional accessory)

8mm hex key required.

The 20" bed extension (p/n 719401) is optional and purchased separately. See our website for information.

The bed extension can be mounted to the upper or lower holes of the lathe at tailstock end, and lower holes at headstock end. Mounting in upper holes increases spindle length capacity of lathe. Mounting extension to lower holes allows use of tool support during outboard turning.

1. Slide tailstock away from edge of bed.

2. Have an assistant hold bed extension flush to end of lathe bed, and insert screws and washers provided with bed extension (P, Figure 5-6). Snug screws just enough to hold bed extension to lathe bed.
3. Unscrew stud from lathe bed (O₁), and insert it into hole at end of bed extension (O₂).
4. Adjust bed extension to lathe bed, aligning the surface and the inside ways as closely as possible.

IMPORTANT: Top surface of bed extension **must** be flush with surface of lathe bed, and inside ways must be aligned, to allow smooth movement of tailstock across joint.

5. Slide tailstock over joint where beds meet, so that clamping nut is centered over joint, as shown in Figure 5-6. Lock tailstock clamping handle; this will align the beds.
6. Securely tighten screws (P) in bed extension.
7. Unlock tailstock and slide it back and forth to test smoothness of joint. Make further adjustments if needed.

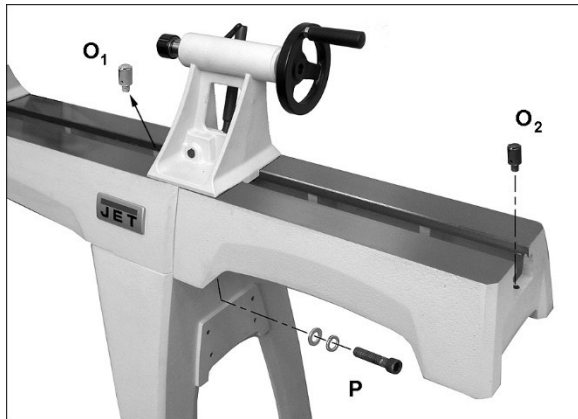

Figure 5-6: installing bed extension (optional)

6.0 Electrical connections

⚠ WARNING Electrical connections must be made by a qualified electrician in compliance with all relevant codes. This machine must be properly grounded to help prevent electrical shock and possible fatal injury.

The JWL-1640EVS lathe requires 115-volt single-phase input. It is equipped with a power inverter, located between the power cord and the drive motor. The inverter takes the 115V 1-phase input from the power cord and converts it to the 230V 3-phase output required by the drive motor.

The lathe comes with a plug designed for use on a circuit with a *grounded outlet* that looks similar to the one pictured in **A**, Figure 6-1.

Before connecting to power source, be sure switch is *off* position.

It is recommended that the lathe be connected to a dedicated 15 amp circuit with a circuit breaker or fuse. If connected to a circuit protected by fuses, use time delay fuse marked "D". **Local codes take precedence over recommendations.**

6.1 GROUNDING INSTRUCTIONS

This tool must be grounded. In the event of a malfunction or breakdown, grounding provides a path of least resistance for electric current to reduce the risk of electric shock. This tool is equipped with an electric cord having an equipment-grounding conductor and a grounding plug. The plug must be inserted into an appropriate outlet that is properly installed and grounded in accordance with all local codes and ordinances.

⚠ WARNING Improper connection of the equipment-grounding conductor can result in a risk of electric shock. Check with a qualified electrician or service person if you are in doubt as to whether the outlet is properly grounded. Do not modify the plug provided with the tool – if it will not fit the outlet, have a proper outlet installed by a qualified electrician.

The conductor with insulation having an outer surface that is green with or without yellow stripes is the equipment-grounding conductor. If repair or replacement of the electric cord or plug is necessary, do not connect the equipment-grounding conductor to a live terminal.

Use only 3-wire extension cords that have 3-prong grounding plugs and 3-pole receptacles that accept the tool's plug.

Repair or replace damaged or worn cord immediately.

6.2 115V operation

As received from the factory, your JWL-1640EVS is ready to run at 115-volt operation. This tool is intended for use on a circuit that has an outlet that looks like the one illustrated in **A**, Figure 6-1. An adapter, shown in **B**, may be used to connect this plug to a 2-pole receptacle as shown in **B** if a properly grounded outlet is not available. The temporary adapter should be used only until a properly grounded outlet can be installed by a qualified electrician. The green-colored rigid ear, lug, and the like, extending from the adapter must be connected to a permanent ground such as a properly grounded outlet box. **Note:** *In Canada, the use of a temporary adaptor is not permitted by the Canadian Electrical Code, C22.1.*

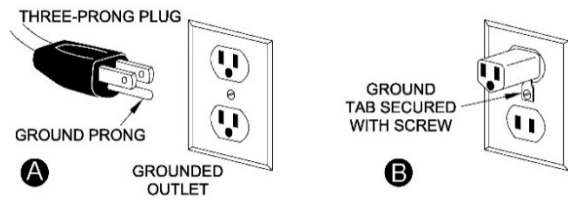

Figure 6-1: grounding

IMPORTANT: The JWL-1640EVS Lathe cannot be run on a GFCI circuit.

CAUTION A lightning strike or power surge may cause inverter failure. When lathe is not in use, disconnect power plug, or have a 3- or 4-pole disconnect installed on the power side.

6.3 Extension cords

The use of extension cords is discouraged; try to position equipment within reach of the power source. If an extension cord becomes necessary, be sure it is heavy enough to carry the current your product will draw. An undersized cord will cause a drop in line voltage resulting in loss of power and overheating.

Table 1 shows recommended size to use depending on cord length and nameplate ampere rating. If in doubt, use the next heavier gauge. The smaller the gauge number, the heavier the cord.

Ampere Rating		Volts	Total length of cord in feet			
More Than	Not More Than		25	50	100	150
		120	25	50	100	150
		240	50	100	200	300
			AWG			
0	6		18	16	16	14
6	10		18	16	14	12
10	12		16	16	14	12
12	16		14	12	Not Recommended	

Extension Cord Recommendations

Table 1

7.0 Adjustments

7.1 Headstock movement

Push handle (A, Figure 7-1) downward to unlock. Headstock will slide freely along length of bed. Push handle up to lock.

WARNING Always lock headstock in position before operating lathe.

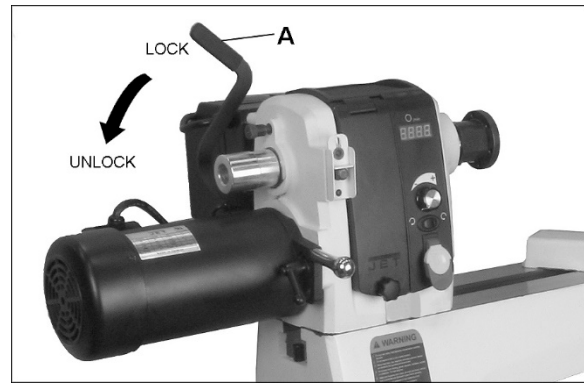

Figure 7-1: headstock movement

7.2 Tailstock movement

To slide tailstock, push locking handle (C, Figure 7-3) down toward bed. Push handle up to lock tailstock in position.

To move quill, loosen handle (D) and rotate handwheel (E).

WARNING Make sure tailstock is locked to bed (C) and quill is tightened (D) before turning a spindle on the lathe.

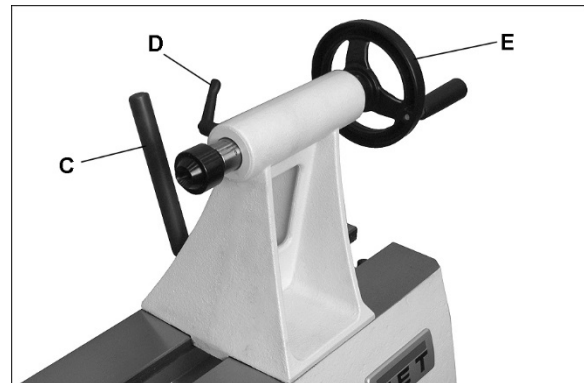

Figure 7-3: tailstock movement

7.3 Removing items from bed

To remove headstock, tailstock or toolrest base from bed, unscrew and remove either of the studs (see O, Figure 5-6). Unlock the item and slide it off bed. After remounting these items on the lathe, reinstall studs.

For most turning operations, except outboard turning, the headstock is positioned at the left end of bed, and the tailstock moved to accommodate the workpiece.

7.4 Cam tightness

The clamping mechanisms of headstock, tailstock and tool rest base are pre-set by the manufacturer, and should not require adjustment.

If one of them does not tighten properly against the bed when the locking handle is tightened, adjust it as follows. (Figure 7-4 uses tailstock as example.)

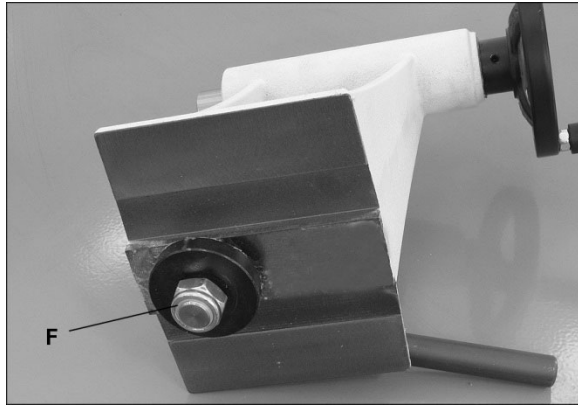

Figure 7-4: cam adjustment

1. Remove stud from end of lathe bed, and slide tailstock off.
2. Turn tailstock on its side, and tighten lock nut (F, Figure 7-4) to increase cam pressure, or loosen the nut to relieve cam pressure.
3. Mount tailstock on bed and lock it to verify adjustment. Repeat as needed.
4. Reinstall stud.

7.5 Tool rest

See Figure 7-5.

A 14-inch tool rest is provided with your lathe. It is designed to allow adjustment for height, position on the bed, and angle to the work.

Loosen locking handle on tool rest base (G, Figure 7-5) to slide base forward or back, and to angle it to the bed. Tighten locking handle firmly before operating lathe.

Loosen handle (H) to raise or lower tool rest and angle it to the work. Tighten handle before operating lathe.

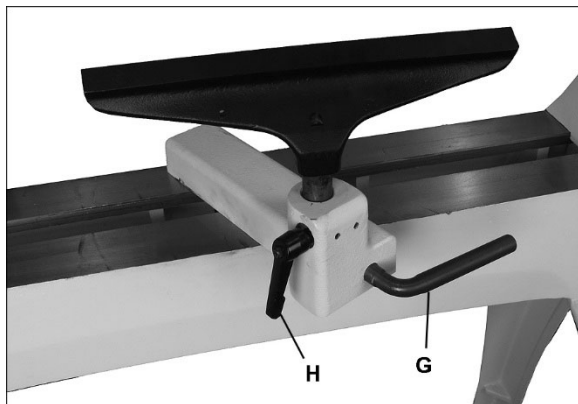

Figure 7-5: tool rest

7.6 Tool rest extension (OPTIONAL)

See Figure 7-6.

The tool rest extension (optional accessory, #JWL1440-TREA, see your dealer to order) mounts to the tool rest base and offers greater reach for the tool rest when turning off the bed,

when the headstock is at the opposite end. See Figure 7-6.

Make sure the clamp bushings (K) are pulled apart sufficiently to accept tool rest post.

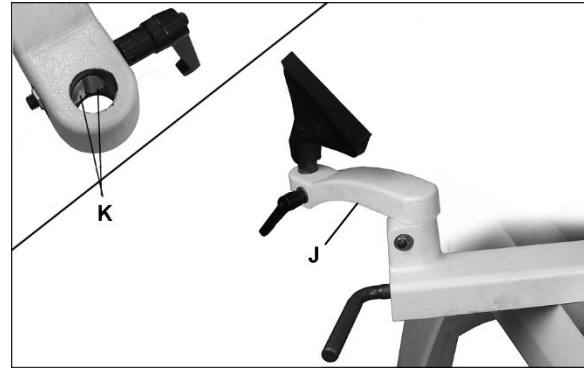

Figure 7-6: optional tool rest extension

7.7 Locking handles

Locking handles, such as H-Figure 7-5, are adjustable. Simply lift out on handle, rotate it on the pin, then release it, making sure it seats itself on the pin.

7.8 Spindle indexing

See Figure 7-7.

Indexing is used to create evenly spaced features in a workpiece, while keeping the lathe spindle locked; for example, when cutting flutes on a spindle blank with a hand-held router, while the spindle blank is secured between lathe centers.

The JWL-1640EVS lathe provides 36 indexing positions at 10-degree increments.

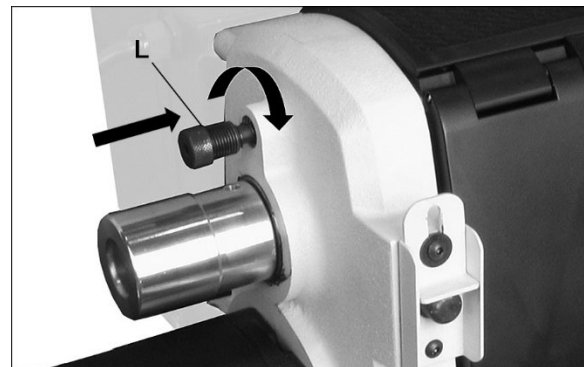

Figure 7-7: index pin

1. Rotate spindle using handwheel until index pin (L, Figure 7-7) aligns with desired hole.
2. Screw index pin into hole until it engages spindle.
3. Perform desired procedure.
4. Unscrew index pin until spindle is released. Rotate spindle to next desired hole, and repeat.

CAUTION

Disengage index pin before starting lathe.

IMPORTANT: Do not use index pin to lock spindle, which will cause unnecessary wear to the pin. Use spindle lock for this purpose.

7.9 Spur center: Installing/removing

The spur center is installed into the headstock spindle. The center should first be mounted to your workpiece, and then installed into the spindle. See *section 9.4*.

1. Disconnect lathe from power source.
2. Clean tapered end of center, and inside of headstock spindle, then push center into headstock spindle.
3. To *remove* a center, first remove workpiece from lathe. Insert knockout rod (Figure 7-8) through hole in handwheel and tap the end of spur center.

IMPORTANT: Hold the center by either placing your thumb and forefinger on outside diameter of spur center, or wrapping the center with a rag. The center can be damaged if allowed to fall.

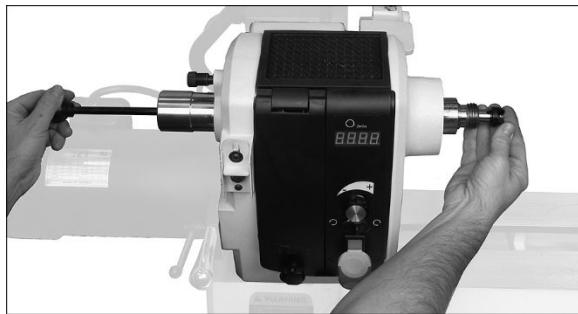

Figure 7-8: removing spur center

7.10 Live center: Installing/removing

Live centers are installed into the tailstock quill. See Figure 7-9.

1. Disconnect lathe from power source.
2. Clean tapered end of center and inside of tailstock quill, then push center into quill. Test the insertion by attempting to pull the center out of the quill by hand. It should remain secure within the quill.
3. Always tighten quill locking handle (M), once the live center has been properly positioned in workpiece. Make sure keyway (N) in quill is aligned with locking handle.

To remove a live center:

4. Back off tailstock and remove workpiece from lathe.
5. Loosen quill lock handle (M).

6. Rotate handwheel counterclockwise to retract quill all the way, until live center comes out. *Hold the center while doing this to prevent it from falling.*

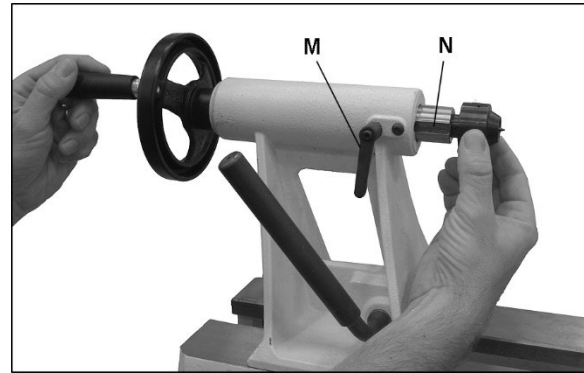

Figure 7-9: installing live center

7.11 Live center and cone

The live center, shown in Figure 7-10, can be used without the cone. To remove cone from live center, first insert pin through hole in live center body as shown. If pin will not insert at first, rotate cone until pin can be inserted. The cone can now be removed by holding the body stationary while unscrewing cone.

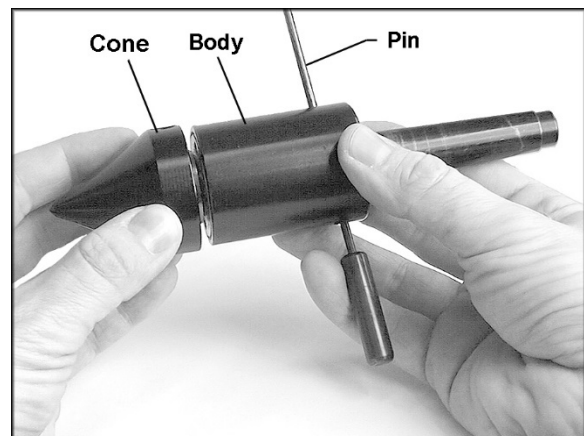

Figure 7-10: removing cone from live center

7.12 Spindle lock

Push spindle lock pin (P, Figure 7-11) and rotate spindle slightly until pin engages. Slide plate downward to hold pin in locking position.

Release spindle lock by pushing plate upward.

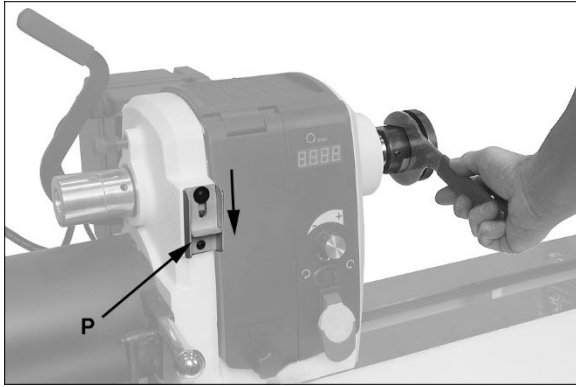

Figure 7-11: spindle lock and face plate

7.13 Face plate: Installing/removing

1. Disconnect lathe from power source.
2. Mount face plate to your workpiece.
3. Engage spindle lock.
4. Install face plate onto threads of headstock spindle and rotate clockwise as far as it will go.
5. Tighten both set screws in face plate. Face plate is now ready for turning.

CAUTION Make certain set screws in face plate are tight before reversing lathe spindle rotation.

6. To *remove* face plate, engage spindle lock. **Loosen both set screws** in face plate, and turn face plate counterclockwise with face plate wrench to loosen.

7.14 Checking center alignment

When headstock is returned from outboard position, the alignment between centers should be checked.

1. Lock headstock in normal spindle turning position.
2. Slide tailstock toward headstock until centers almost touch (see Figure 7-12). Lock tailstock in position.
3. View the center points from top and side to make sure they align.
4. If centers do not align, unlock headstock and pivot it slightly. There should be enough “play” in headstock to adjust for this alignment. Lock headstock when finished.

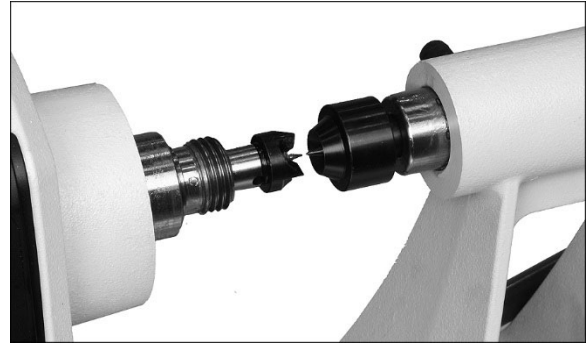

Figure 7-12: center alignment

7.15 Speed Change

See Figure 7-13.

1. Disconnect lathe from power source.
2. To change speed range, open access door on headstock.
3. Loosen pivot lock handle (A, Figure 7-13) and lift up tension handle (B) to raise motor. Tighten pivot lock handle (A) to hold motor in raised position.
4. There should be sufficient slack in the belt to reposition it to the other steps on the sheaves. The label on access door shows required belt position (also shown in Figure 7-14).
5. Loosen pivot lock handle (A) and lower motor to tension belt. Be sure that Poly-V grooves of belt seat properly in corresponding groove of sheave. Do not over-tension; a very light pressure on tension handle (B) is adequate to prevent belt slippage.
6. Tighten pivot lock handle (A) and close access door.

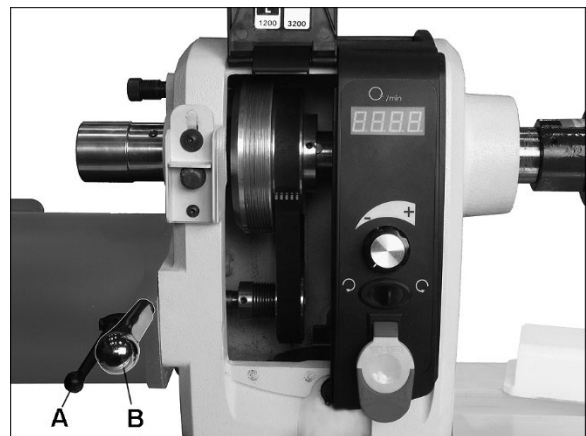

Figure 7-13: speed range adjustment

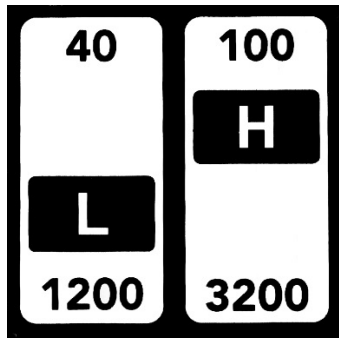

Figure 7-14

8.0 Operating controls

See Figures 8-1, 8-2.

On/off switch (C): Pull to start lathe, push to stop. The safety key (C₁) can be removed to prevent unauthorized use of lathe. The safety key must be inserted to restart the lathe.

Note: If a power outage occurs during operation, the lathe will not immediately restart when power resumes. Cycle the ON switch to restart.

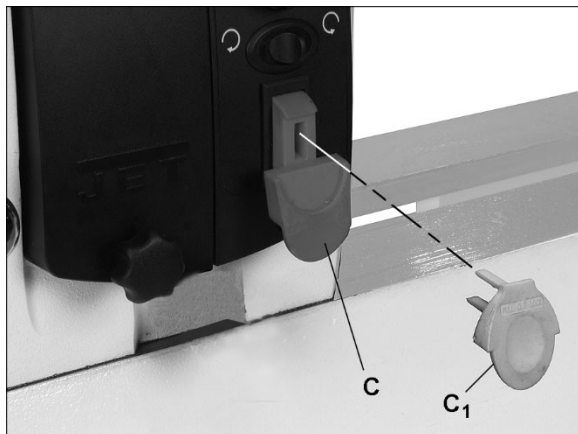

Figure 8-1: switch safety key

Speed control knob (D): Clockwise to increase, counterclockwise to decrease. Speed is displayed as RPM (revolutions per minute) on digital readout (E).

CAUTION Change speed while lathe spindle is turning to avoid overstressing belt.

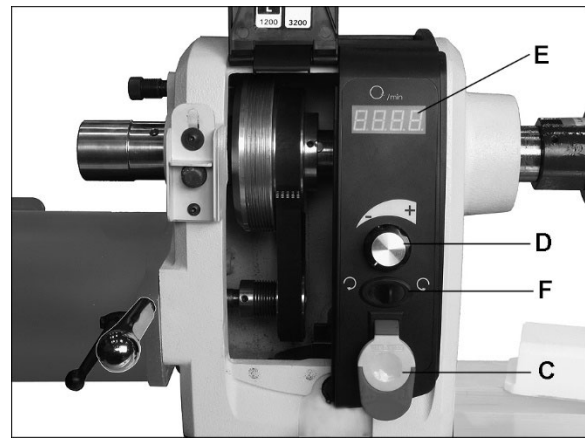

Figure 8-2: operating controls

Forward/Reverse (F)

WARNING When turning with a face plate, make sure both set screws on face plate are tight before reversing spindle direction. Failure to comply may cause face plate to spin loose from spindle.

A.C. Inverter (mounted to rear of headstock)

The 1640EVS Lathe uses the latest technology in A.C. inverter drives to provide infinitely variable spindle speeds within the specified ranges (see sect. 4.0, Specifications). The inverter controls the speed of the motor by varying the frequency of the voltage supplied to the motor. The inverter provides an acceleration ramp that eliminates the shock of normal starting. Also, a braking feature eliminates long coasting periods after the Lathe is turned off.

The 1-1/2 horsepower motor is designed for use with inverter drives, and is balanced to reduce noise and minimize vibration.

The A.C. Inverter is pre-programmed from the factory. **DO NOT ATTEMPT TO ADJUST INVERTER SETTINGS.** Use only the controls on the front of headstock. If you suspect there is a problem with the inverter or inverter settings, contact JET technical service at 1-800-274-6848.

CAUTION A lightning strike or power surge may cause inverter failure. When lathe is not in use, disconnect power plug, or have a 3- or 4-pole disconnect installed on the power side.

9.0 Operation

The information which follows is general in nature and not intended to be a complete course in woodturning. Nothing can replace the knowledge gained by talking with experienced woodturners or consulting books or trade magazines. Above all, simple trial and error will aid in developing proficiency in the craft.

9.1 Inspection

Before operating the lathe, check that everything is in proper working order:

1. Level your machine; use the leveling feet to help reduce vibration.
2. Check bearings; adjust only if endplay exists.
3. Check belt; it should be snug but not overly tight.
4. Bed ways; keep clean, use steel wool to remove any rust spots, and apply paste wax to prevent buildup of rust and finishes.
5. Tool rest; use a mill file to remove nicks and dings.
6. Spindle tapers; should be clean and free of dust and chips for proper seating of tapers.
7. Tailstock; clean and lubricate quill and locking device.
8. Lighting; proper lighting is essential to eliminate shadows and reduce eye strain.

9.2 Turning Tools

If possible, select only good-quality, high-speed steel turning tools. High-speed steel tools hold an edge and last longer than ordinary carbon steel. As one becomes proficient in turning, a variety of specialty tools for specific applications can be acquired. The following tools provide the basics for most woodturning projects (see Figure 9-1):

Skews – 1-1/2" and 1" or 1-1/4", used to make finishing cuts and details.

Large Roughing Gouge – 1" to 1-1/4", used to eliminate waste wood.

Spindle Gouges – 1/4", 3/8", 1/2", used to turn beads, coves and other details.

Deep Fluted Bowl Gouge – 1/4", 3/8" and 1/2", used for turning bowls & plates.

Square Scraper (Bedan) – 3/8" or 1/2", used to create square shoulders.

Large Round Nose (Domed) Scraper – 1-1/2", used to reduce ridges on interior of bowls, round edges of bowls, etc.

Parting Tool - 1/8", used for scraping, making a cut-off, or to set diameters for sizing.

For safety and best performance, *keep tools sharp*. If a tool stops cutting or requires excessive pressure to make a cut, it needs to be sharpened. A number of brand name sharpening jigs and fixtures are available; however, a woodturner should learn to sharpen tools freehand.

For best results, use a slow speed grinder (1800 rpm) fitted with a 60-grit aluminum oxide wheel (for shaping) and a 100-grit alum. oxide wheel (for final sharpening and touchup). The grinder should be located near your lathe and at a comfortable height. A diamond dresser will keep the wheels true and eliminate glazing.

Never allow the tool to rest in one place on the wheel, keep it moving and use a light touch.

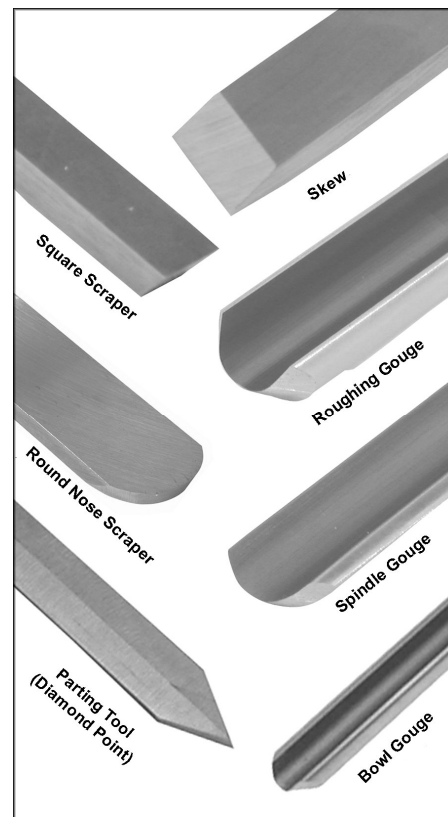

Figure 9-1: basic turning tools

Carbon steel tools can overheat easily and should be cooled frequently. If the edge turns blue, it has lost its temper and should be ground past the blue area. High-speed steel tools are not as likely to overheat, but can be damaged if allowed to get red hot. High-speed steel tools should not be quenched for cooling. Honing with a diamond lap or slipstone will save trips to the grinder and keep the edge fresh.

9.3 Spindle Turning

Spindle turning takes place between the centers of the lathe. It requires a spur or drive center in the headstock and a live or dead center in the tailstock. A cup center rather than a cone center in the tailstock will often reduce the risk of splitting the stock.

Figure 9-2 shows the basic profile shapes in spindle turning.

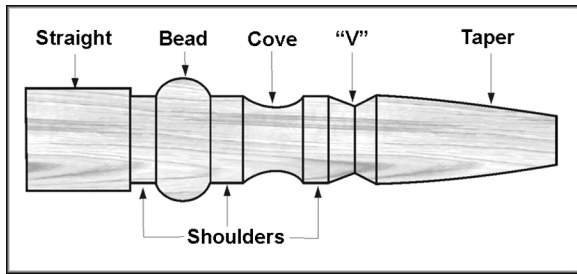

Figure 9-2

9.4 Stock Selection

Stock for spindles should be straight grained and free of checks, cracks, knots and other defects. It should be cut 1/8" to 1/4" larger than the finished diameter and may require additional length so the ends can be removed later. Larger stock should have the corners removed to produce an octagon making the piece easier to rough down to a cylinder.

1. With a combination square, or plastic center finder for round stock, locate and mark center on each end of the workpiece. Accuracy is not critical on full rounds but extremely important on stock where square sections are to remain. Put a dimple in the stock with an awl or nail, or use a spring-loaded automatic center punch.
2. Extremely hard woods may require kerfs cut into the ends of the stock (Figure 9-3) using a band saw, so the wood will accept the spur center and the live center.

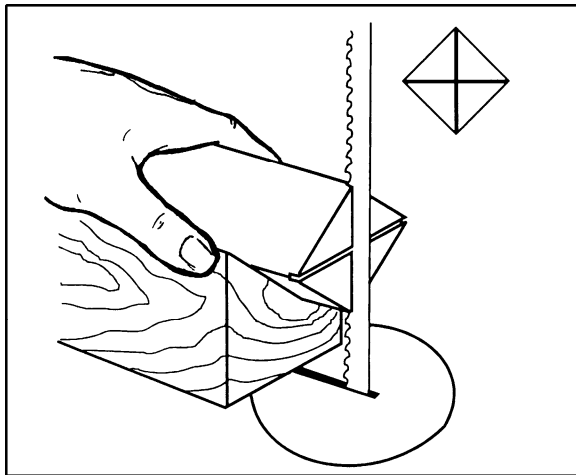

Figure 9-3

3. Drive the spur center about 1/4" into the workpiece, using a wood mallet or dead blow hammer as shown in Figure 9-4. Be careful that you do not split the workpiece.

CAUTION Never use a steel face hammer and never drive the workpiece onto the spur center while it is mounted in the Lathe spindle.

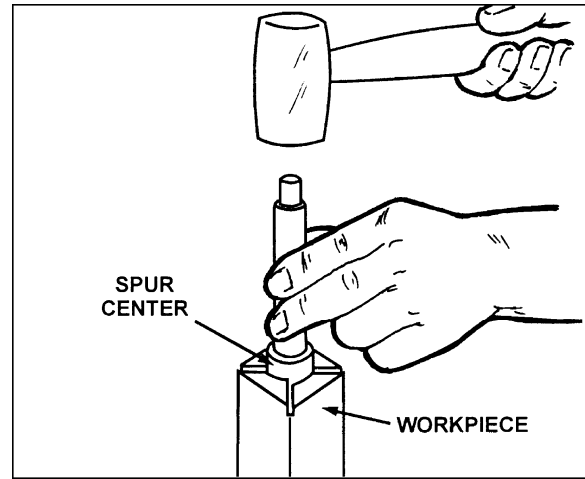

Figure 9-4

4. Make sure headstock is locked to lathe bed.
5. Clean tapered end of spur center and inside of headstock spindle.
6. Insert tapered end of spur center (with the attached workpiece) into headstock spindle.
7. Support the workpiece while bringing the tailstock into position about 1-inch away from end of workpiece. Lock tailstock to bed.
8. Advance tailstock quill with the handwheel in order to seat the live center into the workpiece. Use enough pressure to secure the workpiece between the centers so that it won't fly off, but do not use excessive pressure.
9. Tighten quill locking handle.

CAUTION The tailstock quill is capable of exerting excessive pressure against workpiece and headstock. Apply only sufficient force with tailstock to hold workpiece securely in place. Excessive pressure can overheat center bearings and damage both workpiece and lathe.

10. Move tool rest into position. It should be parallel to workpiece, just below the centerline and approximately 1/8" to 1/4" from the corners of the workpiece to be turned, as in Figure 9-5. Tighten tool rest base to Lathe bed.
11. Rotate workpiece by hand to check for proper clearance.
12. Start lathe at lowest speed and bring it up to the appropriate RPM for the size of workpiece used. Consult digital readout on the headstock.

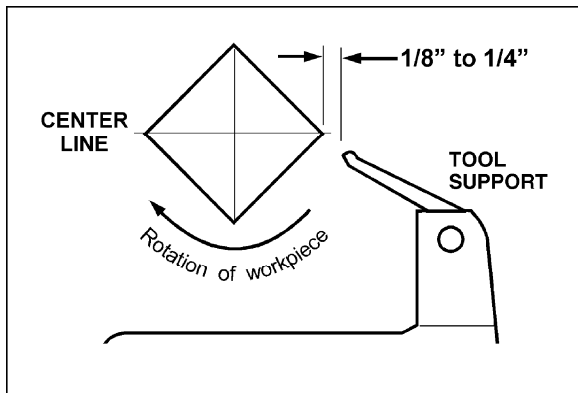

Figure 9-5

9.5 Cutting Techniques

9.5.1 Roughing Out

1. Begin with a large roughing gouge. Place the tool on the tool rest with the heel of the tool on the surface to be cut.
2. Slowly and gently raise tool handle until cutting edge comes into contact with the workpiece.
3. Beginning about 2" from the tailstock end of the workpiece, roll the flute (hollowed-out portion) of the tool in the direction of the cut. See Figure 9-6. Make long sweeping cuts in a continuous motion to rough the piece down to a cylinder.
4. Keep as much of the bevel of the tool as possible in contact with the workpiece to ensure control and avoid catches. **NOTE:** Always cut down-hill, or from large diameter to small diameter. Always work *toward* the end of a work-piece, never start cutting at the end.

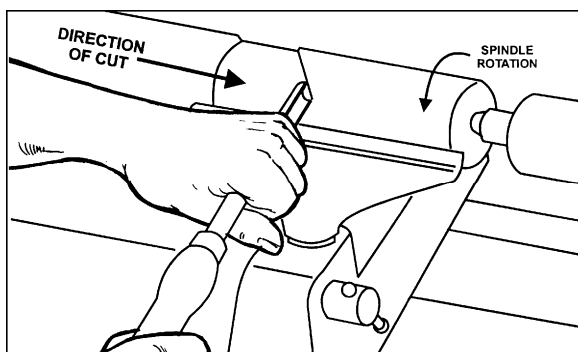

Figure 9-6

5. Once the workpiece is roughed down to a cylinder, smooth it with a large skew. Keep the skew handle perpendicular to the spindle and use only the center third of the cutting edge for a long smoothing cut (touching one of the points of the skew to the spinning workpiece may cause a catch and ruin the workpiece).
6. Add details to the workpiece with skew, parting tool, scraper or spindle gouge.

9.5.2 Beads

1. Make a parting cut for what is to be a bead to the desired depth. Place the parting tool on the tool support and move tool forward to make the full bevel of the tool come into contact with the workpiece. Gently raise handle to make cut to the appropriate depth.
2. Repeat for other side of the bead.
3. Using a small skew or spindle gouge, start in the center between the two cuts and cut down each side to form the bead. Roll the tool in direction of cut.

9.5.3 Coves

1. Use a spindle gouge. With the flute of the tool at 90 degrees to the workpiece, touch the point of the tool to the workpiece and roll in towards the bottom of the cove. See Figure 9-7. **Stop at the bottom; attempting to go up the opposite side may cause the tool to catch.**

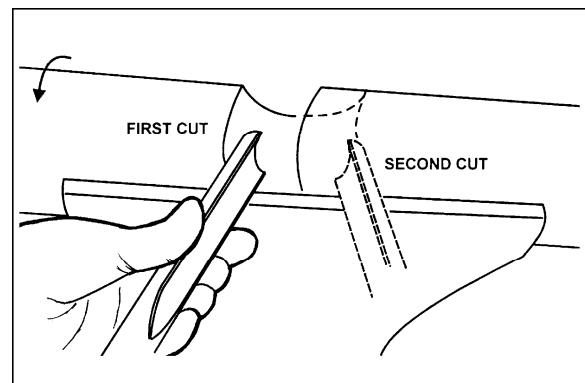

Figure 9-7

2. Move the tool over the desired width of the cove.
3. With the flute facing the opposite direction, repeat step 1 for other side of cove. Stop at bottom of cut.

9.5.4 "V" Cuts

1. Use the long point of the skew. (**NOTE:** Do not press the long point of the skew directly into the workpiece to create the "V"; this will result in a burned or burnished "V" with fibers being rolled up at both sides.)
2. Lightly mark the center of the "V" with the tip of the skew.
3. Move the point of the skew to the right half of the desired width of your cut.
4. With the bevel parallel to the right side of the cut, raise the handle and push the tool in to the desired depth, as shown in Figure 9-8.

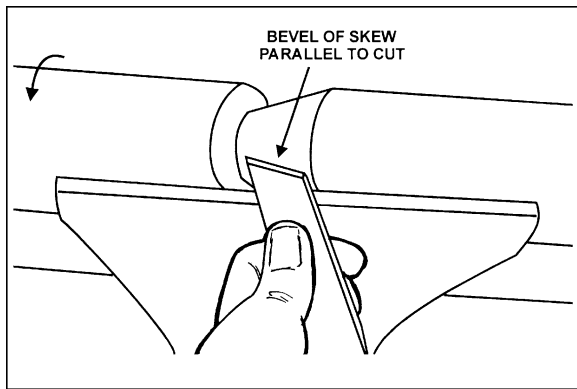

Figure 9-8

5. Repeat from the left side. The two cuts should meet at the bottom and leave a clean "V" cut.
6. Additional cuts may be taken to add to either the depth or width of the cut.

9.5.5 Parting Off

1. Use parting tool.
2. Adjust lathe speed to lower RPM for parting through a workpiece.
3. Place tool on tool support and raise the handle until it starts to cut and continue to cut toward center of workpiece.
4. Loosely hold on to the piece in one hand as it separates from the waste wood.

9.5.6 Sanding and Finishing

Leaving clean cuts will reduce the amount of sanding required. Move the tool support out of the way, adjust the lathe to a **low speed**, and begin with fine sandpaper (120 grit or finer). Coarser sandpaper will leave deep scratches that are difficult to remove, and dull crisp details on the spindle. Progress through each grit without skipping grits (for example, do not jump from 120 grit to 220 grit). Fold the sandpaper into a pad; do not wrap sandpaper around your fingers or the workpiece. To apply a finish, the workpiece can be left on the lathe.

Turn off lathe and use a brush or paper towel to apply the finish. Remove excess finish before restarting lathe. Allow to dry and sand again with 320 or 400 grit sandpaper. Apply second coat of finish and buff.

9.6 Face Plate and Bowl Turning

Face plate turning is normally done on the inboard side of the headstock over the bed. Larger workpieces must be turned on the outboard side. Rotate headstock to desired position; or remove tailstock and tool support base, and slide headstock to opposite end of bed.

9.6.1 Mounting Stock

Use of a face plate is the most common method for holding a block of wood for turning bowls and plates:

1. Select stock at least 1/8" to 1/4" larger than each dimension on the finished workpiece.
2. Always select the largest diameter face plate that can be used for the workpiece to be turned.
3. True one surface of the workpiece for mounting against the face plate.
4. Using the face plate as a template, mark the location of the mounting holes on the workpiece, and drill pilot holes of the appropriate size. Face plates are drilled for No. 12 screws. (Phillips and square drive screws will hold up better than slotted screws. Steel metal screws are case hardened with deeper and sharper threads than wood screws.)

If the mounting screws on the face plate interfere with the workpiece, a glue or waste block can be used:

5. Make a block the same diameter as the face plate, Figure 9-9. Both waste block and workpiece should have flat surfaces for gluing.
6. Glue the block to the workpiece. Avoid using brown paper or newspaper between the waste block and workpiece. It may work fine if you are using scrapers, but a slight catch with a bowl gouge can separate the two.

NOTE: When using a waste block, be careful with the adhesive you select. Dry workpieces can be bonded with ordinary white or yellow glue but must be clamped to ensure a good bond. Green workpieces require cyanoacrylate type glue.

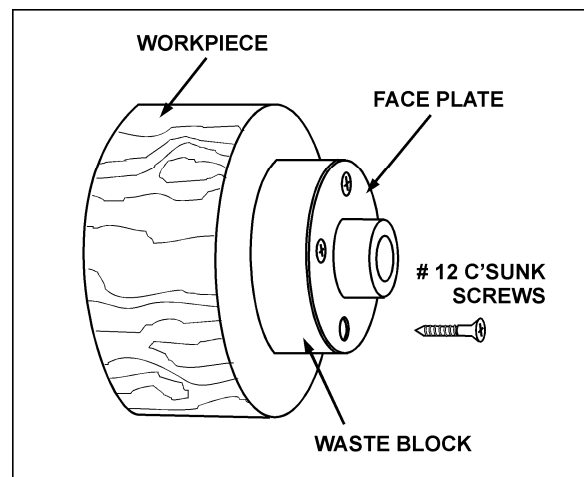

Figure 9-9

9.6.2 Faceplate or Chuck?

While faceplates are the simplest, most reliable method of holding a block of wood for turning, chucks can also be used.

As there are dozens of chucks to choose from, the woodturner should first consider all the different types of turning that will be done, and read reports or discuss with other turners who own chucks before making a decision.

A chuck is not a requirement, but is handy when working on more than one piece at a time. Rather than removing screws, you simply open the chuck and change workpieces.

The most popular ones are four jaw scroll chucks with a variety of jaws to accommodate different size tenons. Most also come with a screw chuck as well.

9.6.3 Wood Selection

Firewood is the cheapest, most widely available stock to use while learning to turn bowls. Simply waste wood for a while practicing turning techniques. Develop skill with each tool before attempting to make a finished piece. It is best to start with dry wood, without worrying about drying or distortion. Once turning becomes comfortable, try green wood which cuts very easily. As the turner gains experience, he or she will find extraordinary grain and figure in the form of burls, crotches and bark inclusions.

9.6.4 Checks and Cracks

Green wood will check and crack. For best results, leave logs in as long a length as you can handle. As the material starts to dry, surface cracks will develop on the ends of the log. Cut off two to three inches and you should find good, sound wood. Also cut the log in half along the pith to avoid having it in the finished piece. Most checks radiate from the pith.

As you turn bowls from green wood, make sure you maintain a consistent wall thickness throughout the piece. Leaving a piece thick in some areas and thin in others will cause the wood to dry unevenly and promote checks and cracks.

9.6.5 Distortion

Distortion is a problem associated with turning green wood. It will vary from one type of wood to the next. Typically, fruitwoods tend to distort more than others. It also varies with the time of year the tree was cut and how the logs are stored.

9.6.6 Tools for Bowl Turning

The deep fluted bowl gouge is the most essential and versatile tool for most bowl and plate turning. The bowl gouge is heavier and easier to control than other types of gouges. It also allows removal of wood much faster and with less vibration than other gouges. Most average sized bowl work can be accomplished with a 3/8" or 1/2" bowl gouge.

A 1/4" bowl gouge is best suited for smaller bowls and light finishing cuts. Larger 3/4" and 1" bowl gouges are only used for extremely large pieces.

Large domed scrapers can also be used to help clean up the interior surfaces of bowls. A light touch with the scraper slightly tilted will eliminate some of the ridges occasionally left by an inexperienced bowl gouge.

9.7 Bowl Turning Techniques

9.7.1 To Shape Outside of Bowl

1. Odd shaped burls, crotches and other irregular shaped blanks require special preparation before mounting in a chuck or onto a faceplate. Remove the bark, if there is any, from what appears to be the center of the top of the workpiece.
2. Drive spur center into the top of the workpiece with a mallet or dead blow hammer.
3. Slip the spur center into the headstock taper and bring the tailstock with a live or ball bearing center into position. Lock the tailstock to the bed and advance the tailstock spindle in order to seat the cup center into the workpiece. Tighten the ram locking handle.
4. Turn workpiece by hand to ensure proper clearance.
5. Start lathe at lowest speed and bring it up to the maximum safe speed for the size of work to be turned. If the machine starts to vibrate, lower the speed until vibration stops.
6. Rough out the outside of the bowl with the 1/2" deep fluted bowl gouge, holding the handle of the tool firmly against your hip. For best control, use your whole body to move the gouge through the workpiece.
7. As the bowl takes shape, work on the bottom (tailstock end) to accommodate attaching a face plate.
8. Turn a short tenon (about 1/8" long) the size of the hole in the faceplate. See Figure 9-10. This will allow centering the workpiece when the faceplate is attached.

(NOTE: If you plan to use a chuck, turn a tenon of the appropriate length and diameter to fit your chuck.)

9. Stop the lathe, remove workpiece and attach face plate or chuck (see section 9.6.1 "Mounting Stock").

⚠WARNING The surfaces of faceplate and workpiece should mount flush to each other.

10. Finish turning the outside of bowl with 1/2" or 3/8" bowl gouge. Leave additional material at base of bowl for support while turning interior. This will be removed later.

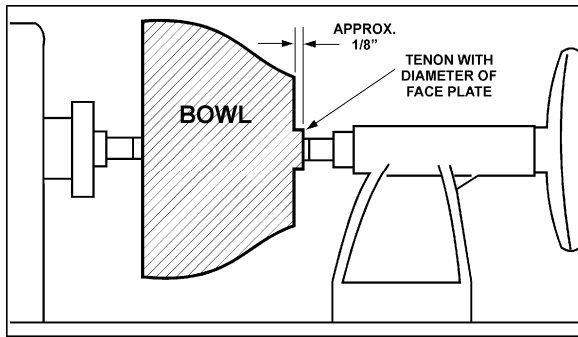

Figure 9-10

9.7.2 To Shape Interior of Bowl

1. Stop lathe and move tailstock away. (You may want to remove the center from the tailstock to avoid bumping it with your elbow.)
2. Adjust tool support in front of the bowl just below centerline, at a right angle to the lathe ways.
3. Rotate workpiece by hand to check clearance.
4. Face off top of bowl by making a light shearing cut across the top of workpiece, from rim to center.
5. Place 1/2" bowl gouge on tool support at center of the workpiece with the flute facing top of bowl. The tool handle should be level and pointed toward the four o'clock position, as shown in Figure 9-11.

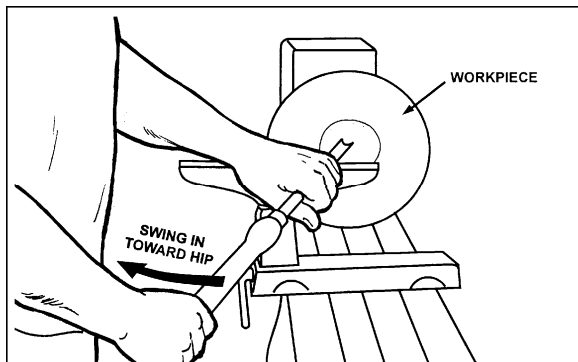

Figure 9-11

6. Use the left hand to control cutting edge of gouge, while right hand swings tool handle toward your body (Figure 9-11). The flute should start out facing top of workpiece, and rotate upward as it moves deeper into the bowl to maintain a clean even curve. As the tool goes deeper into the bowl, progressively work out toward the rim. It may be necessary to turn the tool support into the piece as you get deeper into the bowl.

(NOTE: Try to make one, very light continuous movement from the rim to the bottom of the bowl to ensure a clean, sweeping curve through the piece.)

Should there be a few small ridges left, a light cut with a large domed scraper can even out the surface.)

7. Develop wall thickness at the rim and maintain it as you work deeper into the bowl (Once the piece is thin toward the bottom, you cannot make it thinner at the rim). When the interior is finished, move the tool support to exterior to re-define bottom of bowl. (General rule of thumb: the base should be approximately 1/3 the overall diameter of the bowl).
8. Work the tight area around faceplate or chuck with 1/4" bowl gouge.
9. Begin the separation with a parting tool, but do not cut all the way through yet.

9.7.3 Sanding and Finishing

1. Remove the tool support and adjust lathe speed to approximately 500 RPM. Higher speeds can build friction while sanding and cause heat check in some woods.
2. Begin with fine sandpaper (120 grit) and progress through each grit, using only light pressure. Coarser sandpaper tends to leave deep scratches that are hard to eliminate. Use power-sanding techniques to avoid concentric sanding marks around your finished piece. Avoid rounding over the rim and foot with sandpaper; try to keep details crisp. Finish sanding with 220 grit.
3. Remove sanding dust with tack rags or compressed air and, with lathe turned off, apply first coat of finish. Let stand for several minutes, wipe off excess. Allow to dry before sanding again with 320 or 400 grit sandpaper.
4. Turn lathe back on and continue the separation cut almost all the way through the base. Stop at about 3" and use a small fine tooth saw to separate the bowl from the waste.
5. Apply second finish coat and allow to dry before buffing.

10.0 Maintenance

⚠WARNING Before doing maintenance on the lathe, disconnect it from the electrical supply by pulling out the plug or switching off the main switch. Failure to comply may cause serious injury.

10.1 General procedures

Maintenance on the 1640EVS lathe should be performed at periodic intervals to ensure that the machine is in proper working order, that all fasteners are tight, and all necessary adjustments have been made. Inspection and maintenance should be performed at least twice a year, but more frequently if the lathe receives constant use.

Clean and oil the lathe bed so that headstock, tailstock and tool rest base will slide easily. Clean any rust spots that may develop on the bed with a commercial rust remover.

Use compressed air to blow out the interior of the headstock, in order to keep sawdust and chips from accumulating on belts and sheaves. Also blow off debris that accumulates in the motor fan and around inverter. **Do not disassemble inverter to clean!**

Frequently clean out the Morse tapers on both headstock and tailstock. Commercially available taper cleaners may be acquired from tool stores.

Bearings are permanently lubricated and sealed, and do not require further lubrication.

10.2 Pulley and belt alignment

The motor and spindle pulleys are aligned with each other by the manufacturer, but if any service is performed that affects their alignment it is very important that they be realigned. Engage spindle lock, loosen two set screws on spindle pulley (E, Figure 9-12) with 3mm hex key, and slide spindle pulley into proper position. Retighten set screws, and disengage spindle lock.

When pulleys and belt are properly aligned, there should be no unusual pulsing sounds or noise coming from the belt.

10.3 Pulley and belt replacement

See Figure 9-12.

3mm hex key required.

To change out a belt or pulley, carefully proceed as follows. If you are uncertain about attempting a belt or pulley change-out, contact JET technical service or take the headstock to an authorized service center.

1. Disconnect lathe from power source.
2. Loosen pivot lock handle (A, Figure 9-12) and lift up tension handle (B) to raise motor.
3. Tighten pivot lock handle (A) to secure motor in raised position.
4. Slip belt off pulleys.
5. Loosen two set screws on handwheel (C).
6. Engage spindle lock (D) and unscrew handwheel from spindle (left-hand threads, clockwise to loosen).
7. Slide spindle a little way out of headstock, just enough to remove pulley or belt.

NOTE: If needed, tap end of spindle with a wood block or rubber mallet to move it. Do **NOT** use a steel face hammer directly against spindle.
8. If replacing a pulley, loosen both set screws (E), and slide pulley off spindle.
9. Install new pulley, loosely securing the two set screws. Make sure pulley is oriented properly and key is inserted properly in spindle groove.
10. Slide spindle back into place.
11. Reinstall handwheel (C) and tighten set screws.
12. Align new pulley (see *sect. 10.2*) then tighten both set screws securely on pulley.
13. Loosen pivot lock handle (A) and lower motor using tension handle (B). Re-tighten pivot lock handle.
14. Disengage spindle lock.

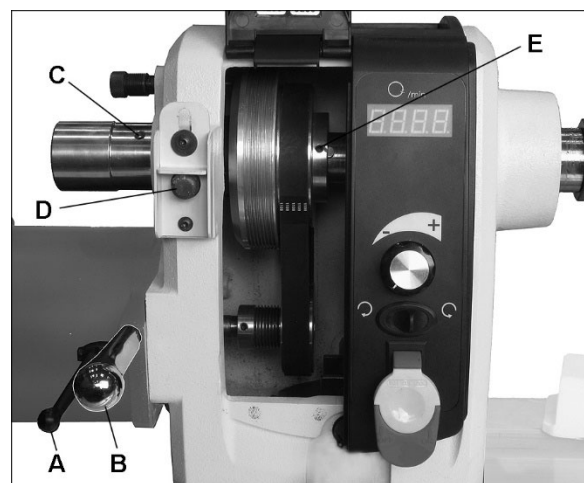

Figure 9-12

11.0 Troubleshooting JWL-1640EVS Lathe

Table 2

Symptom	Possible Cause	Correction *
Motor fails to develop full power.	Power line overloaded.	Correct overload condition.
	Undersized wires in supply system, or extension cord is too long.	Increase supply wire size.
	Low voltage.	Request voltage check from power company and correct low voltage condition.
	Worn motor.	Replace motor.
Motor or spindle stalls or will not start.	Excessive cut.	Reduce depth of cut.
	Worn or broken belt.	Replace belt.
	Improper cooling of motor.	Blow out sawdust from motor housing fan.
	Worn spindle bearings.	Replace bearings.
	Worn motor.	Replace motor.
Excessive vibration or noises.	Workpiece warped, out of round, has major flaw, was improperly prepared for turning.	Correct problem by planing or sawing workpiece, or discard entirely and use new workpiece.
	Spindle rotation too fast.	Reduce speed.
	Worn spindle bearings.	Replace spindle bearings.
	Drive belt misaligned or worn.	Align belt. Replace if worn.
	Motor mount bolts are loose.	Tighten bolts.
	Lathe on uneven surface.	Adjust leveling feet.
Tools tend to grab or dig in.	Dull tools.	Keep tools sharp.
	Tool rest set too low.	Reposition tool rest height.
	Tool rest set too far from workpiece.	Reposition tool rest closer to workpiece.
	Improper tool being used.	Use correct tool for operation.
Headstock moves when applying pressure with Tailstock.	Locking handle not tight.	Tighten handle.
	Excessive pressure being applied by tailstock.	Slide headstock to left end, lock firmly, then apply pressure to workpiece with tailstock. Apply <i>only</i> sufficient force with tailstock to hold workpiece securely in place.
Tailstock moves when applying pressure.	Cam lock nut needs adjusting.	Tighten cam lock nut.
	Excessive pressure being applied by tailstock. (Note: The screw action of the tailstock is capable of applying excessive pressure to workpiece and headstock. Apply only sufficient force by tailstock to hold workpiece securely in place. Excessive pressure can cause damage to machine.)	Slide tailstock to right side of lathe against the stop. Move headstock into position and apply pressure to workpiece with tailstock.
	Lathe bed and tailstock mating surfaces are greasy or oily.	Remove tailstock and clean surfaces with a cleaner/degreaser. Re-apply light coat of oil to lathe bed surface.
Digital readout does not work.	Digital sensor out of position.	Open belt access and position sensor so that it reads the bolts.

* **Warning:** Some corrections may require a qualified electrician.

12.0 Recommended Lathe Speeds (per diameter of workpiece)

Diameter of Work	Roughing RPM	General Cutting RPM	Finishing RPM
Under 2"	1520	3000	3000
2" to 4"	760	1600	2290
4" to 6"	510	1080	1500
6" to 8"	380	810	1125
8" to 10"	300	650	900
10" to 12"	255	540	750
12" to 14"	220	460	640
14" to 16"	190	400	560
16" to 20"	175	325	450
20" to 24"	175	260	375

Table 3

13.0 Optional accessories

These accessory items, purchased separately, can enhance the functionality of your lathe. Contact your dealer to order, or call JET at the phone number on the cover.

- 719001 Tailstock Swing Away
- 719002 Guard
- 719401 20" Extension Bed w/ Post
- JWL1440-TREA Tool Rest Extension Assembly

14.0 Replacement Parts

Replacement parts are listed on the following pages. To order parts or reach our service department, call 1-800-274-6848 Monday through Friday, 8:00 a.m. to 5:00 p.m. CST. Having the Model Number and Serial Number of your machine available when you call will allow us to serve you quickly and accurately.

Non-proprietary parts, such as fasteners, can be found at local hardware stores, or may be ordered from JET. Some parts are shown for reference only, and may not be available individually.

14.1.1 JWL-1640EVS Headstock Assembly – Exploded View

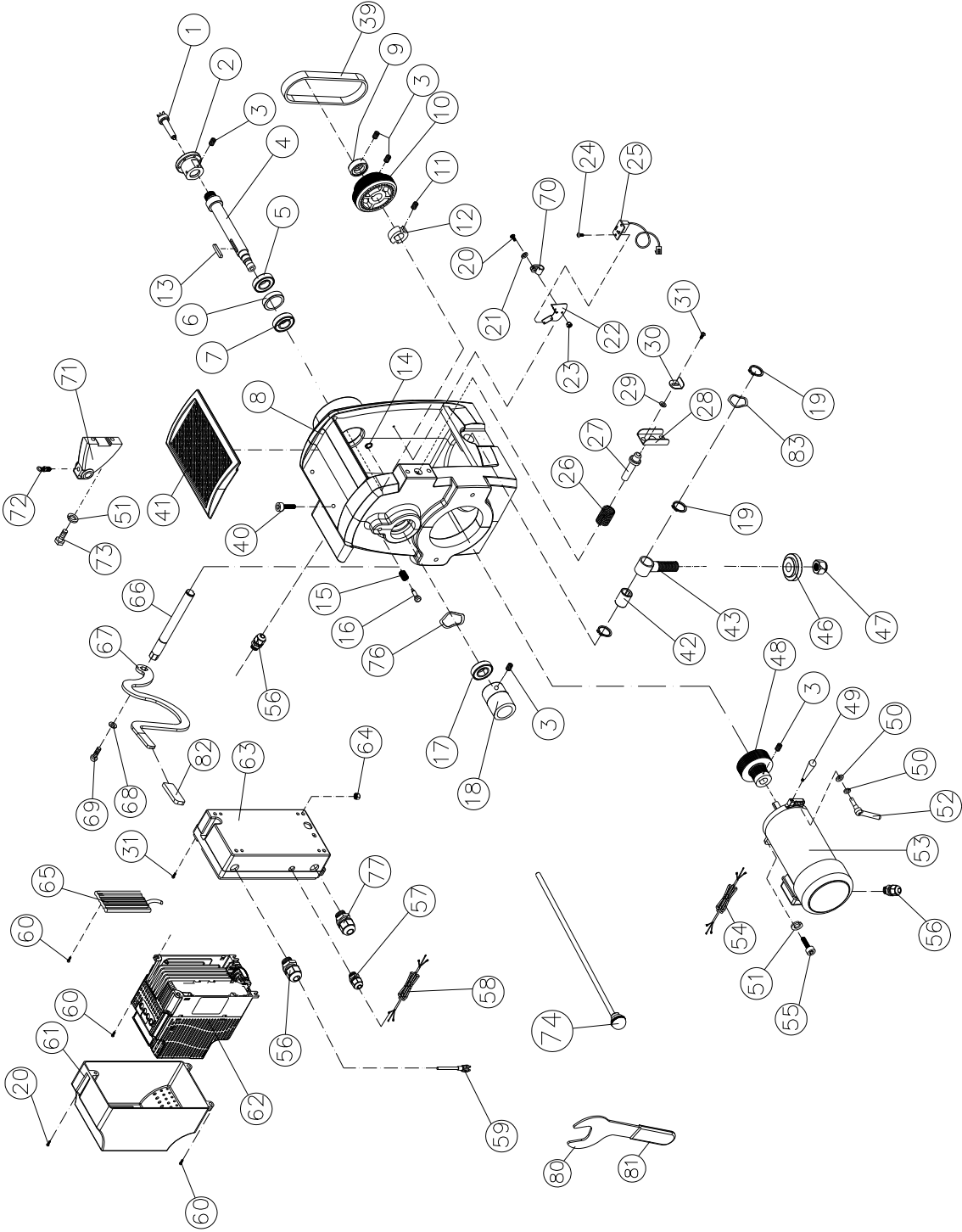

14.1.2 JWL-1640EVS Headstock Assembly – Parts List

Index No.	Part No.	Description	Size	Qty
1	JWL1642-102	Spur Center	MT2	1
2	6294736	Faceplate	3"	1
3	6295796	Nylon Insert Socket Set Screw	1/4-20x3/8"	10
4	JWL1640EVS-104	Spindle		1
5	BB-6207VV	Bearing	6207-LLB	1
6	3520B-208	Bushing		1
7	BB-6207ZZ	Bearing	6207ZZ	1
8	JWL1640EVS-108A	Headstock Casting, Sliding		1
9	JWL1640EVS-109	Sensor Collar		1
10	JWL1640EVS-110	Spindle Pulley		1
11	TS-0270031	Set Screw	5/16"-18x3/8"	2
12	JWL1642-174	Locking Collar		1
13	JWL1640EVS-113	Key	8 x 8 x 80	1
14	JWL1640EVS-114	C-Ring	S-8	1
15	JWL1640EVS-115	Spring		1
16	JWL1640EVS-116	Index Pin		1
17	BB-6205ZZ	Bearing	6205ZZ	1
18	JWL1640EVS-118	Handwheel		1
19	JWL1640EVS-119	C-Ring	S-19	4
20	TS-081C052	Pan Head Screw	#10-24x3/4"	4
21	TS-069204	Flat Washer	#10	1
22	JWL1640EVS-122	Cover for Sensor		1
23	TS-0560071	Hex Nut	#10-24	3
24	TS-2283102	Pan Head Screw	M3x10	2
25	JWL1640EVS-125	Sensor for Spindle		1
26	JWL1442-116	Spring		1
27	JWL1640EVS-127	Spindle Lock Pin		1
28	JWL1442-121	Bracket		1
29	4224B-143	Resist Washer		1
30	4224B-1122E	Sliding Plate		1
31	TS-0253031	Socket Head Button Screw	#10-24x1/2"	6
39	JWL1640EVS-139	Belt	208J-8	1
40	JWL1640EVS-140	Socket Head Cap Screw	10#-24x1/4"	2
41	JWL1640EVS-141	Cushion		1
42	JWL1442-127	Bushing		1
43	JWL1442-128A	Bolt		1
46	JWL1442-154	Clamp		1
47	TS-0650081	Nylon Nut	3/4"-10	1
48	JWL1640EVS-148	Motor Pulley		1
49	4224B-165	Handle		1
50	TS-0680041	Flat Washer	3/8"	2
51	TS-0720091	Lock Washer	3/8"	3
52	6350031	Lock Handle		1
53	JWL1640EVS-153	Motor		1
54	JWL1642-172	Motor Cord		1
55	TS-0209051	Socket Head Cap Screw	3/8"-16x1"	1
56	JWL1440-141	Strain Relief	M16	3
57	JML-70E	Strain Relief	PG9	1
58	JWL1640EVS-158	Signal Cord		1
59	JWL1640EVS-159	Power Cord		1
60	JWL1640EVS-160	Pan Head Screw	#10 - 24 x1"	8
61	JWL1640EVS-161	Inverter Upper Cover		1
62	JWL1640EVS-162	Inverter	VFD007E11A	1
63	JWL1640EVS-163	Inverter Lower Box		1
64	TS-0560071	Hex Nut	#10-24	7
65	JWL1642-169	Braking Resistor		1
66	JWL1640EVS-166A	Eccentric Rod		1
67	JWL1640EVS-167	Handle with Rubber Grip (includes #82)		1
68	TS-0680042	Flat Washer	3/8"	1
69	TS-0209011	Socket Head Cap Screw	3/8"-16x1/2"	1

Index No.	Part No.	Description	Size	Qty
70	JWL1642-183	Clamp		2
71	JWL1640EVS-171	Safety Guard Bracket		1
72	6644005	Plunger		1
73	JWL1640EVS-173	Hex Bolt	3/8"-16 x 1-3/8"	2
74	JWL1442-164	Knock Out Rod		1
76	JWL1442-108	Wave Washer		1
77	JWL1642-196E	Strain Relief	PG 13.5	1
80	JWL1221VS-269E	Wrench (includes #81)		1
81	JWL1221VS-270	Rubber Grip		1
82	JWL1640EVS-182	Rubber Grip		1
83	JWL1840EVS-193	Wave Washer	BWW-629	1

14.2.1 JWL-1640EVS Controller Assembly – Exploded View

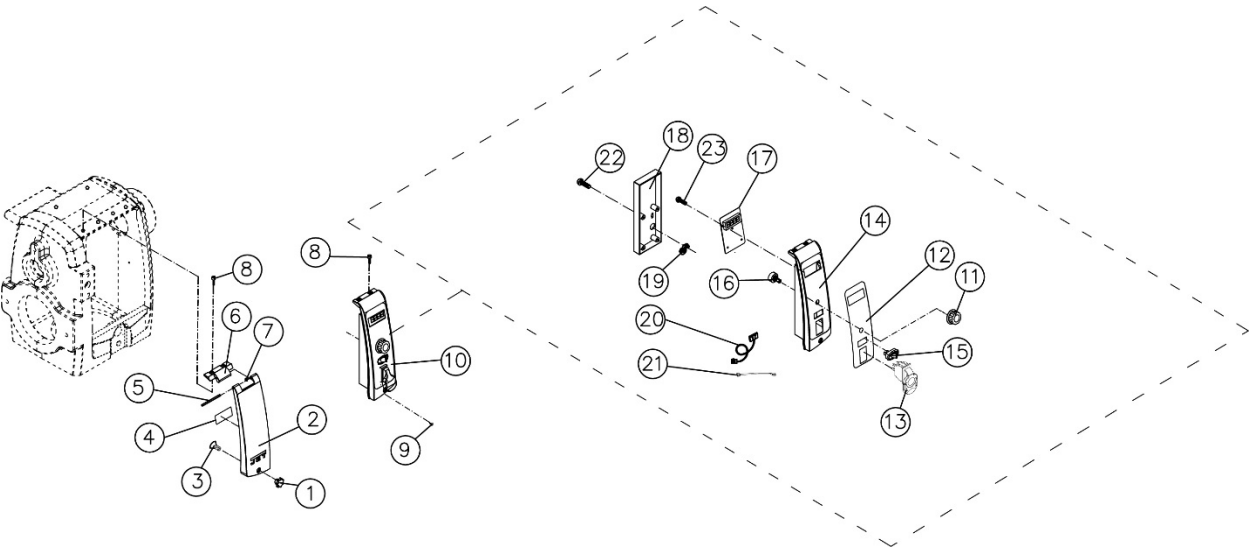

14.2.2 JWL-1640EVS Controller Assembly – Parts List

Index No.	Part No.	Description	Size	Qty
1	JWL1640EVS-201	Knob		1
2	JWL1640EVS-202	Access Door (With Magnets)		1
3	TS-2248252	Socket Head Button Screw	M8-1.25Px25	1
4	LM000171	Speed Label		1
5	JWL1640EVS-205	Pin		1
6	JWL1640EVS-206	Hinge		1
7	JWL1640EVS-207	O- Ring		1
8	TS-0253031	Socket Head Button Screw	#10-24x1/2"	4
9	JWL1640EVS-160	Pan Head Screw	#10-24x1"	1
10	JWL1640EVS-CA	Controller Assembly (includes #11 thru 23)		1
11	JWL1642-143	Variable Speed Knob		1
12	LM000066	Control Panel Label		1
13	JWL1640EVS-213	Main Switch		1
14	JWL1640EVS-214	Control Front Cover (includes #12)		1
15	4224B-148	Switch Fwd/Rev		1
16	6295915	Control Pot Assembly		1
17	JWL1640EVS-217	PC Board		1
18	JWL1640EVS-218	Back Box		1
19	JWL1221VS-320	Strain Relief		1
20	JWL1640EVS-220	Signal Cord (inverter to control box)		1
21	JWL1640EVS-221	Connection Cord (Spindle Sensor to PC board)		1
22	TS-2284082	Machine Screw	M4x8	4
23	TS-2171012	Machine Screw	M4x6	4

14.3.1 JWL-1640EVS Bed and Stand Assemblies – Exploded View

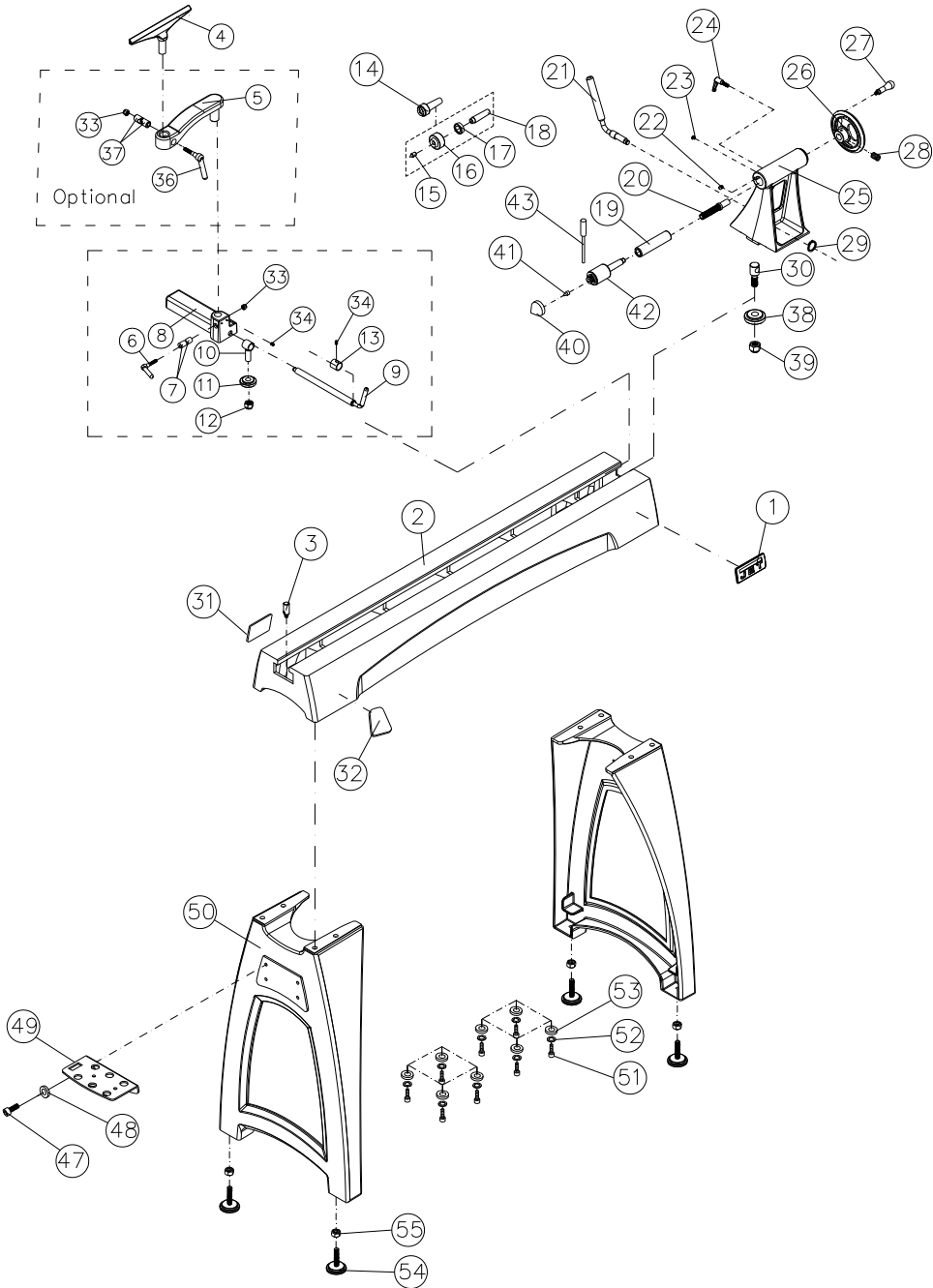

14.3.2 JWL-1640EVS Bed and Stand Assembly – Parts List

Index No.	Part No.	Description	Size	Qty
1	JET-113	JET Logo	113 x 47 mm	1
2	JWL1440-202	Bed		1
3	JWL1440-203	Stud		2
4	JWL1642-211	Tool Rest	14"	1
	JWL1440-TREA	Optional Tool Rest Extension Assembly (includes #5, 33, 36, 37)		1
5	JWL1440-205	Tool Rest Extension, Optional		1
	JWL1440-TBA	Tool Rest Base Assembly (includes #6 thru 13, 33, 34)		1
6	JWL1440-206	Handle		1
7	JWL1440-207	Tool Rest Lock Bushing Set		1
8	JWL1440-208	Tool Rest Base		1
9	JWL1442-210A	Tool Support Rod		1
10	JWL1442-128	Clamp Bolt		1
11	JWL1442-154	Clamp		1
12	TS-0650081	Hex Nylon Lock Nut	3/4"-10	1
13	JWL1440-213	Bushing		1
14	708331	Live Center Assembly (includes #15 thru 18)		1
15	JML-52A	Center Point for Live Center		1
16	JML-52	Live Center Head		1
17	BB-6002ZZ	Ball Bearing	6002ZZ	1
18	JML-54	Live Center Shaft		1
	JWL1640EVS-TA	Tailstock Assembly (includes #19 thru 30, 38, 39)		1
19	JWL1640EVS-319	Quill	MT-2	1
20	JWL1640EVS-320	Lead Screw		1
21	JWL1440-221	Tailstock Rod		1
22	JWL1221VS-227	Key		1
23	F009674	Socket Head Button Screw	#10-32x5/8"	1
24	JML-59A	Tailstock Lock Handle		1
25	JWL1640EVS-325	Tailstock Casting		1
26	JWL1440-226	Handwheel		1
27	JWL1442-211	Handle		1
28	TS-0267041	Set Screw	1/4"-20x 3/8"	2
29	JWL1440-229	C-Ring	S-12	1
30	JWL1440-230	Bolt		1
31	LM000170	ID Label		1
32	JWL1221VS-211	Warning Label		1
33	TS-0570031	Hex Nut	3/8"-16	2
34	TS-0267021	Set Screw	1/4"-20x1/4"	4
36	JWL1440-206	Handle, Optional		1
37	JWL1440-207	Tool Rest Lock Bushing Set, Optional		1
38	JWL1442-154	Clamp		1
39	TS-0650081	Hex Nylon Lock Nut	3/4"-10	1
	6295902	Live Center Assembly (includes #40 thru 43)		1
40	6295905	Live Center Cone		1
41	6295904	Live Center Tip		1
42	6295903	Live Center Body		1
43	6295906	Live Center Rod		1
47	TS-0209061	Socket Head Cap Screw	3/8"-16x1-1/4"	2
48	TS-0680041	Flat Washer	3/8"	2
49	JWL1640EVS-349	Tool Shelf		1
50	JWL1440-401	Leg		2
51	TS-0208071	Socket Head Cap Screw	5/16"-18x1-1/4"	8
52	TS-0720081	Lock Washer	5/16"	8
53	TS-0680031	Flat Washer	5/16"	8
54	JWL1642-206	Adjustable Foot	3/8"	4
55	TS-0561031	Hex Nut	3/8"-16	4
	JWL1440-HP1	Hardware Package (includes #51, 52, 53)		

14.4.1 JWL-1640EVS Extension Bed Assembly (OPTIONAL) – Exploded View

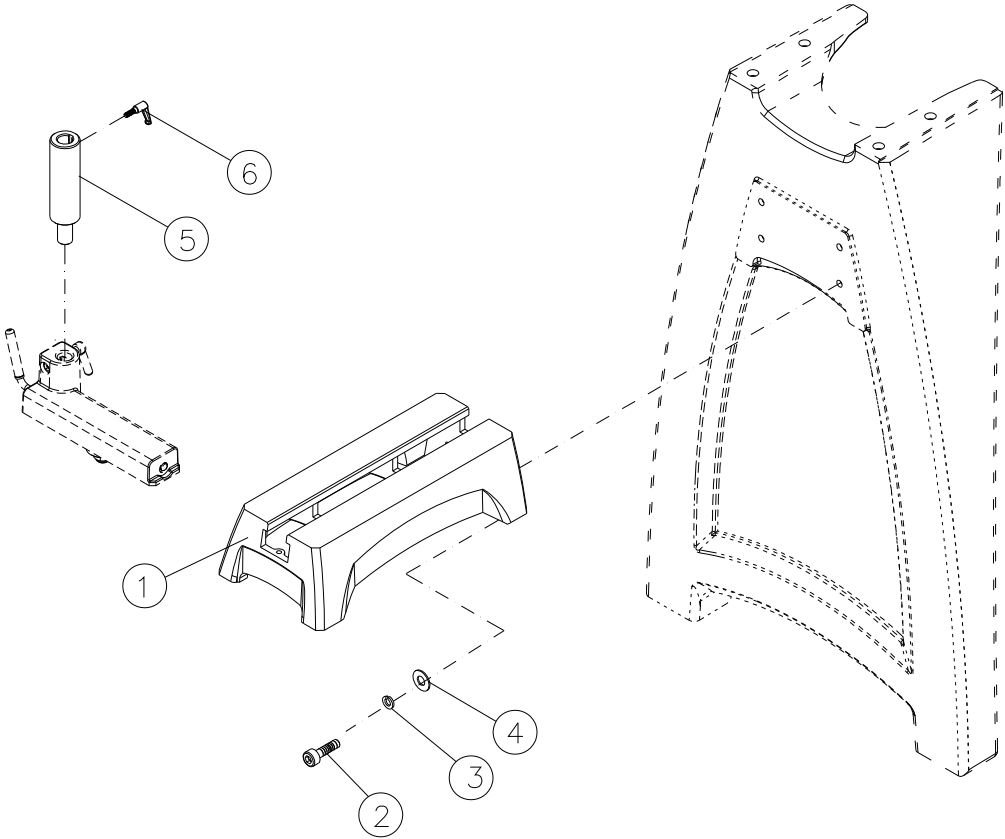

14.4.2 JWL-1640EVS Extension Bed Assembly (OPTIONAL) – Parts List

Index No.	Part No.	Description	Size	Qty
.....	719401	20" Extension Bed w/ Post (includes #1 thru 6)	1
1	JWL1440-301	Extension Bed	20"	1
2	TS-0209071	Socket Head Cap Screw	3/8"-16x1-1/2"	4
3	TS-0720091	Lock Washer	3/8"	4
4	TS-0680041	Flat Washer	3/8"	4
5	3520B-310	Extension Post	1
6	6294763	Locking Handle	1

14.5.1 JWL-1640EVS Guard Assembly (OPTIONAL) – Exploded View

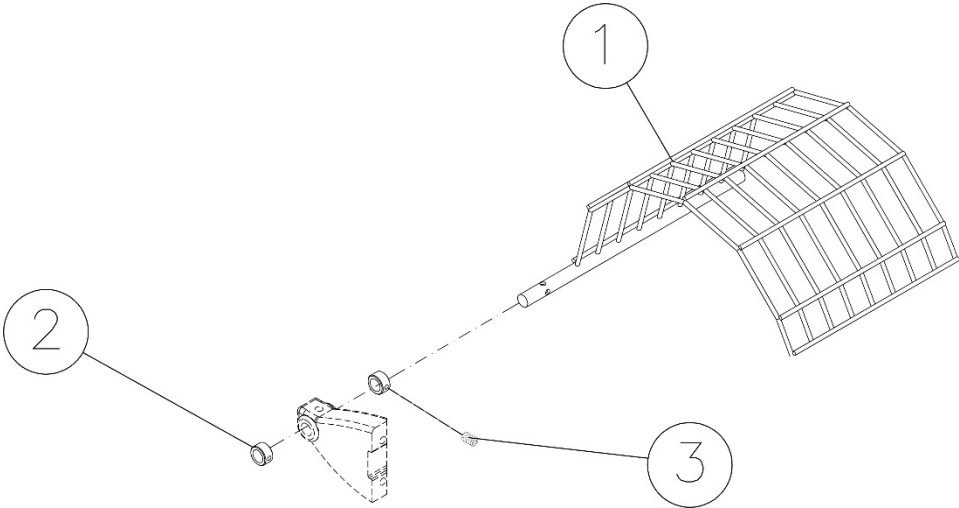

14.5.2 JWL-1640EVS Guard Assembly (OPTIONAL) – Parts List

Index No.	Part No.	Description	Size	Qty
.....	719002	Lathe Guard Assembly (includes #1 thru 3)
1	JWL1642-179	Guard	1
2	JWL1642-187	Collar	2
3	TS-0270011	Set Screw	5/16"-18 x 1/4"	2

15.0 Electrical Connections for JWL-1640EVS

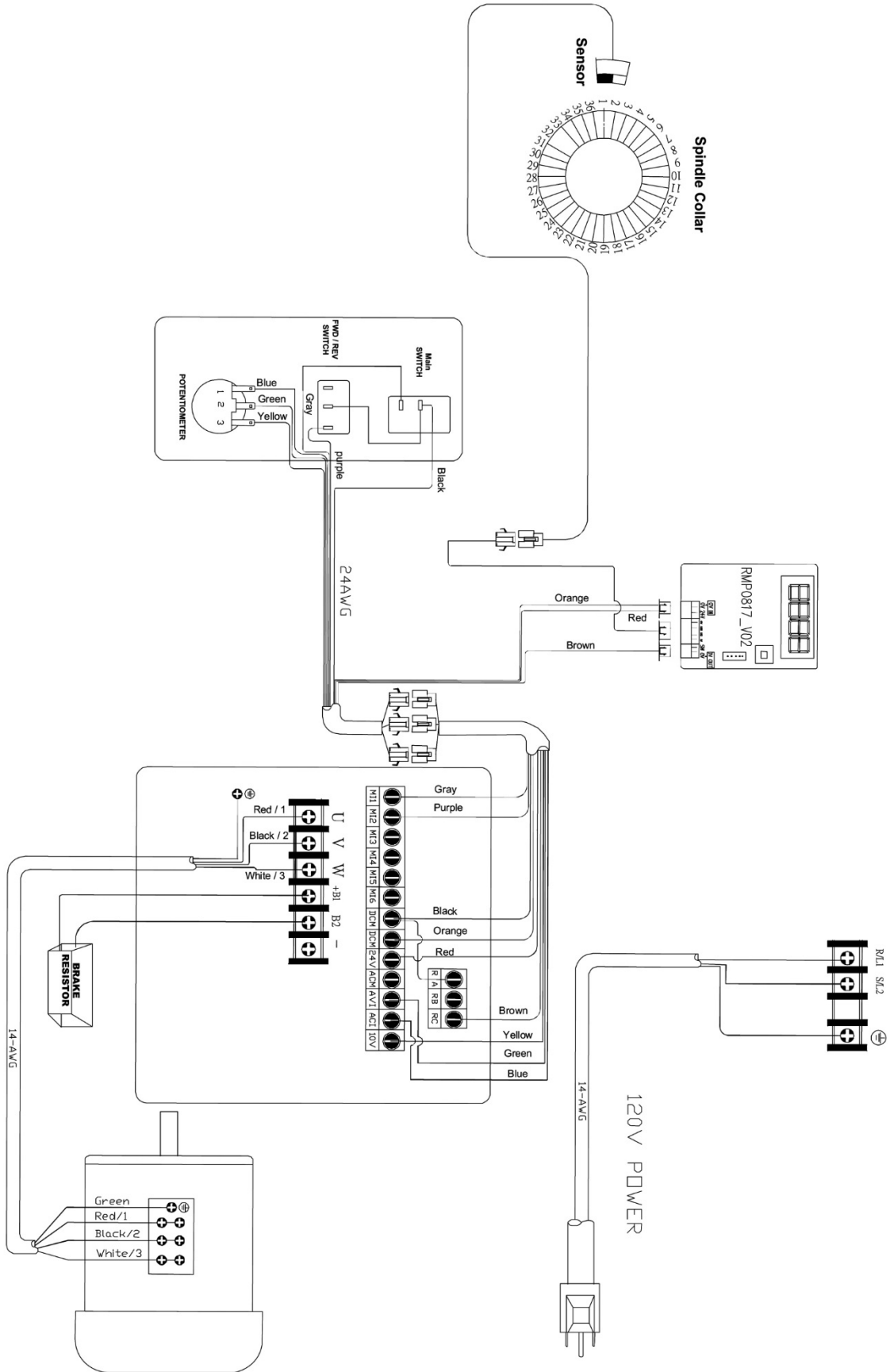

16.0 Warranty and Service

JET warrants every product it sells against manufacturers' defects. If one of our tools needs service or repair, please contact Technical Service by calling 1-800-274-6846, 8AM to 5PM CST, Monday through Friday.

Warranty Period

The general warranty lasts for the time period specified in the literature included with your product or on the official JET branded website.

- JET products carry a limited warranty which varies in duration based upon the product. (See chart below)
- Accessories carry a limited warranty of one year from the date of receipt.
- Consumable items are defined as expendable parts or accessories expected to become inoperable within a reasonable amount of use and are covered by a 90 day limited warranty against manufacturer's defects.

Who is Covered

This warranty covers only the initial purchaser of the product from the date of delivery.

What is Covered

This warranty covers any defects in workmanship or materials subject to the limitations stated below. This warranty does not cover failures due directly or indirectly to misuse, abuse, negligence or accidents, normal wear-and-tear, improper repair, alterations or lack of maintenance. JET woodworking machinery is designed to be used with Wood. Use of these machines in the processing of metal, plastics, or other materials may void the warranty. The exceptions are acrylics and other natural items that are made specifically for wood turning.

Warranty Limitations

Woodworking products with a Five Year Warranty that are used for commercial or industrial purposes default to a Two Year Warranty. Please contact Technical Service at 1-800-274-6846 for further clarification.

How to Get Technical Support

Please contact Technical Service by calling 1-800-274-6846. **Please note that you will be asked to provide proof of initial purchase when calling.** If a product requires further inspection, the Technical Service representative will explain and assist with any additional action needed. JET has Authorized Service Centers located throughout the United States. For the name of an Authorized Service Center in your area call 1-800-274-6846 or use the Service Center Locator on the JET website.

More Information

JET is constantly adding new products. For complete, up-to-date product information, check with your local distributor or visit the JET website.

How State Law Applies

This warranty gives you specific legal rights, subject to applicable state law.

Limitations on This Warranty

JET LIMITS ALL IMPLIED WARRANTIES TO THE PERIOD OF THE LIMITED WARRANTY FOR EACH PRODUCT. EXCEPT AS STATED HEREIN, ANY IMPLIED WARRANTIES OF MERCHANTABILITY AND FITNESS FOR A PARTICULAR PURPOSE ARE EXCLUDED. SOME STATES DO NOT ALLOW LIMITATIONS ON HOW LONG AN IMPLIED WARRANTY LASTS, SO THE ABOVE LIMITATION MAY NOT APPLY TO YOU.

JET SHALL IN NO EVENT BE LIABLE FOR DEATH, INJURIES TO PERSONS OR PROPERTY, OR FOR INCIDENTAL, CONTINGENT, SPECIAL, OR CONSEQUENTIAL DAMAGES ARISING FROM THE USE OF OUR PRODUCTS. SOME STATES DO NOT ALLOW THE EXCLUSION OR LIMITATION OF INCIDENTAL OR CONSEQUENTIAL DAMAGES, SO THE ABOVE LIMITATION OR EXCLUSION MAY NOT APPLY TO YOU.

JET sells through distributors only. The specifications listed in JET printed materials and on official JET website are given as general information and are not binding. JET reserves the right to effect at any time, without prior notice, those alterations to parts, fittings, and accessory equipment which they may deem necessary for any reason whatsoever. JET® branded products are not sold in Canada by JPW Industries, Inc.

Product Listing with Warranty Period

90 Days – Parts; Consumable items
1 Year – Motors; Machine Accessories
2 Year – Metalworking Machinery; Electric Hoists, Electric Hoist Accessories; Woodworking Machinery used for industrial or commercial purposes
5 Year – Woodworking Machinery
Limited Lifetime – JET Parallel clamps; VOLT Series Electric Hoists; Manual Hoists; Manual Hoist Accessories; Shop Tools; Warehouse & Dock products; Hand Tools; Air Tools

NOTE: JET is a division of JPW Industries, Inc. References in this document to JET also apply to JPW Industries, Inc., or any of its successors in interest to the JET brand.

This page intentionally left blank.

This page intentionally left blank.



427 New Sanford Road
LaVergne, Tennessee 37086
Phone: 800-274-6848
www.jettools.com