

# WILLOW DRESS

waste free

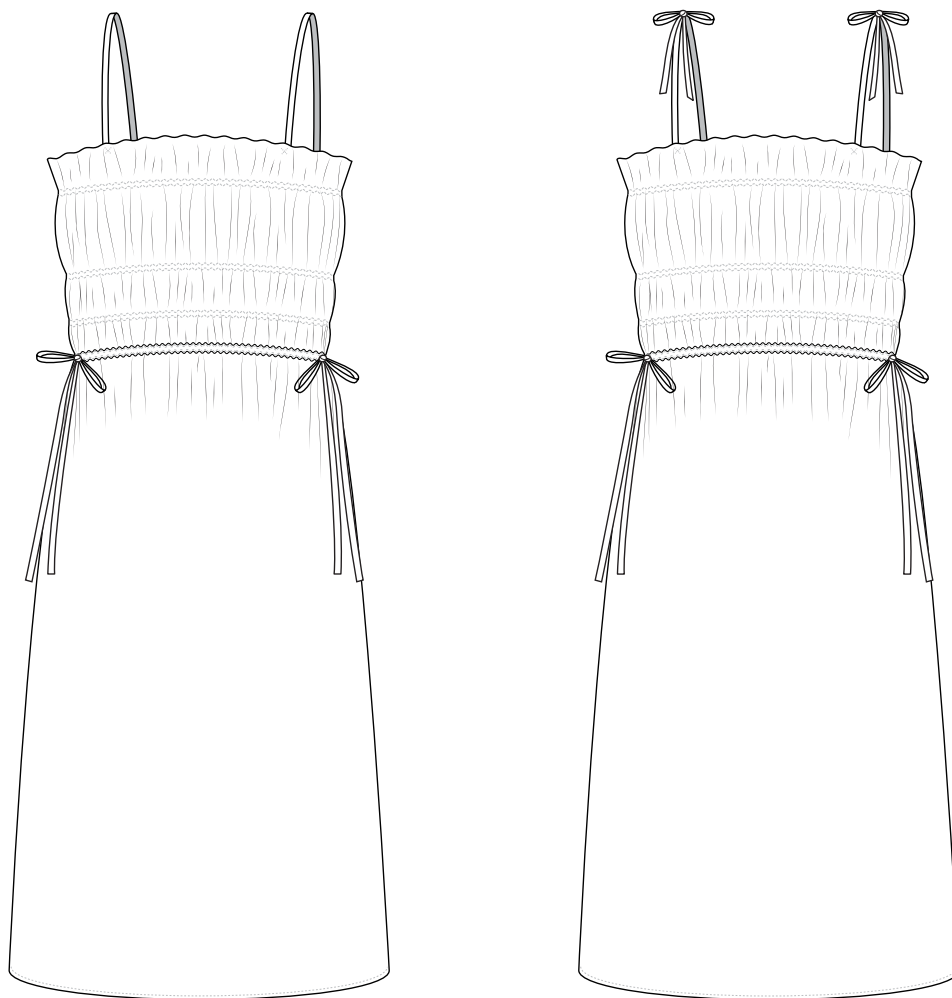

## Common Stitch.

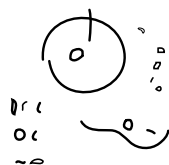

*Sewing patterns for people of the modern era.*

WILLOW WASTE FREE DRESS

*The Willow Dress is a waste free sewing pattern, made exactly for your body measurements.  
A simple midi/maxi length (dependant on your height), with gathered elastic features to create shape and support.  
Waist ties bring it all together and add a nice feature to this simple dress.*

*Perfect for lounging on a boat, at the beach or out to dinner.  
Wear at ease knowing this dress hasn't created any fabric wastage!*

*We've even created a full sew-along video for the more visual learners,  
watch it **HERE** on our YouTube channel.*

*We hope this simple waste free pattern can fill some gaps in your handmade wardrobe!*

Find us on Instagram @common\_stitch and tag your photo with #CommonStitch and #WillowWasteFreeDress

**COME HANG OUT WITH US ON YT FOR A FULL SEW ALONG  
VIDEO TUTORIAL ON THE WILLOW DRESS [HERE](#)**

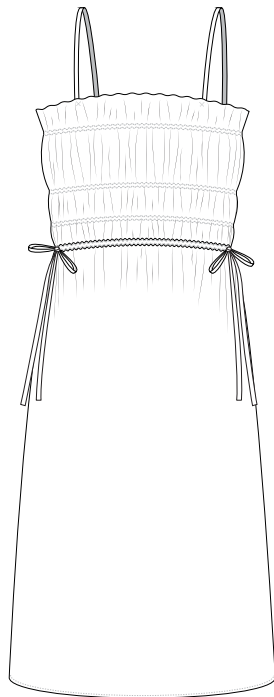

*Option A  
Fixed Straps*

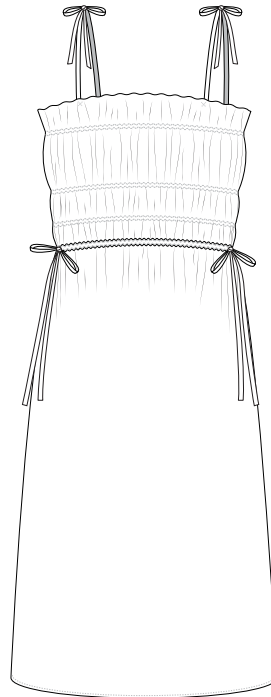

*Option B  
Tie Straps*

# WILLOW DRESS

---

## PATTERN PIECES

1 Dress	Cut one
2 Binding Channels	Cut four
3 Shoulder Straps	Cut two
4 Waist Ties	Cut two

## REQUIRED NOTIONS

Matching Thread  
1cm wide Elastic (enough to go around your torso 3 times)

## SEWING LEVEL

Beginner

**CHECK OUT OUR FULL SEW ALONG VIDEO FOR THE WILLOW DRESS [HERE](#)**

## EQUIPMENT REQUIRED

Sewing machine  
A good pair of sewing scissors  
Pins  
Markers chalk  
Safety Pin

## SEAM ALLOWANCES

All seams have a 1cm (0.4 inch) seam allowance, unless noted otherwise.

## SUGGESTED FABRICS

Woven Fabrics, such as linen, cotton, linen/cotton blends.

Check out our simple guide to selecting eco-friendly fabrics for your sewing projects [HERE](#)

## NOTES

a space to write notes about your make!

# WILLOW DRESS

## Cutting Instructions

### OPTION A - SHORT SHOULDER STRAPS

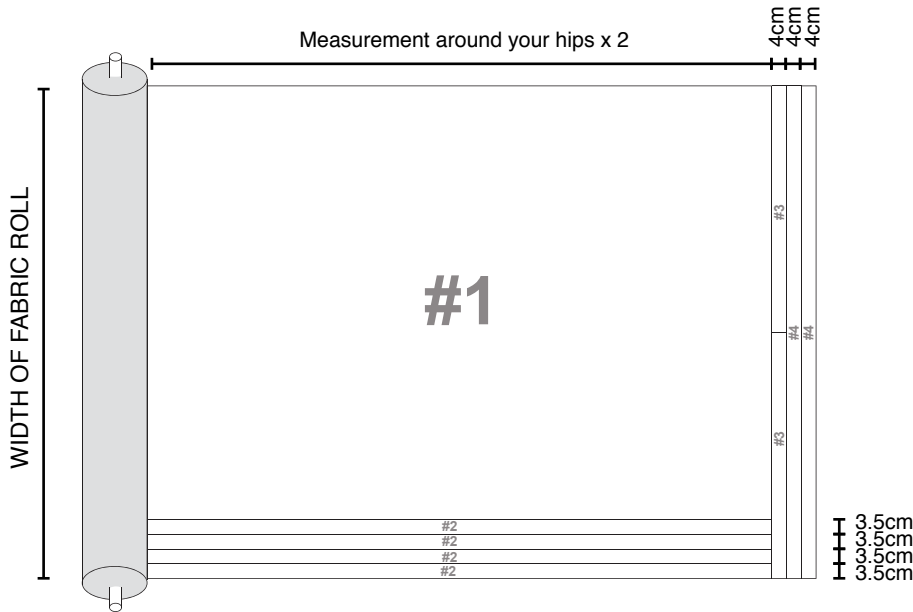

- #1 Dress  
The Measurement around your hips x 2
- #2 Binding Channels  
The length of piece #1 x 3.5cm (cut x four)
- #3 Shoulder Straps  
4cm x half the width of your fabric (cut x two)
- #4 Waist Ties  
4cm x the width of your fabric (cut x two)

#### HOW MUCH FABRIC DO I NEED?

12cm + Measurement around your hips x 2

#### Example:

Ali is a size 8 (Aus) and her hip measurement is 84cm (168cm when doubled)

The amount of fabric she requires is;  
12cm + 168cm = 180cm of fabric (1.8m)

### OPTION B - LONG SHOULDER STRAPS

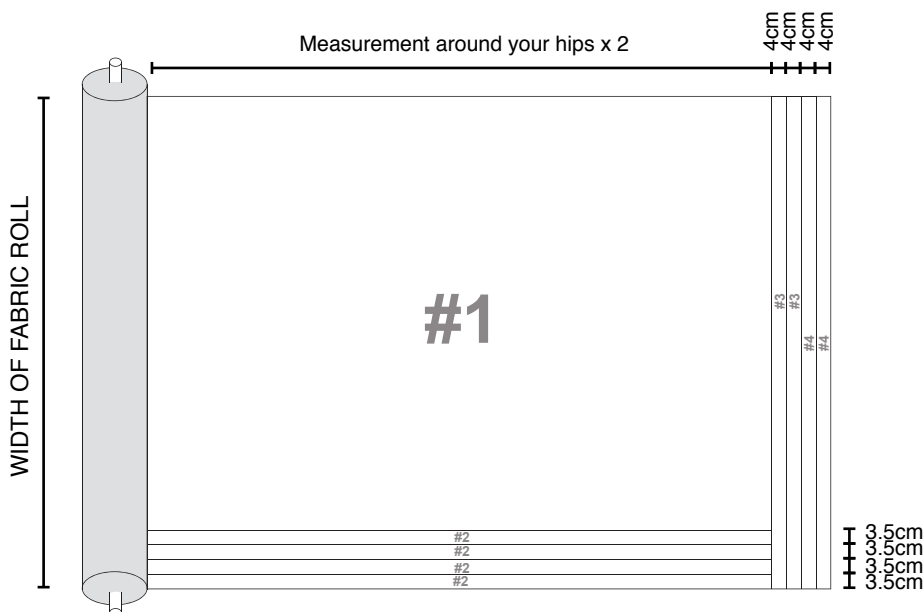

- #1 Dress  
The Measurement around your hips x 2
- #2 Binding Channels  
The length of piece #1 x 3.5cm (cut x four)
- #3 Shoulder Straps  
4cm x the width of your fabric (cut x two)
- #4 Waist Ties  
4cm x the width of your fabric (cut x two)

#### HOW MUCH FABRIC DO I NEED?

16cm + Measurement around your hips x 2

#### Example:

Ali is a size 8 (Aus) and her hip measurement is 84cm (168cm when doubled)

The amount of fabric she requires is;  
16cm + 168cm = 184cm of fabric (1.84m)

**BEFORE YOU START  
YOUR PROJECT**

Please read all instructions prior to starting work on your garment.

We recommend pre-washing all your fabrics and trims before sewing, to allow for any shrinkage.

Seam allowances for all garment pieces are 1cm (0.4 inch) unless indicated otherwise.

Neaten your seams + give your garments a longer life by either using an overlocker or a regular zig-zag stitch on your seams.

We recommend pressing the seams as you go.

**GLOSSARY OF TERMS**

**BACK STITCH**

at the beginning and end of each line of continuous stitches sew four stitches forward and four stitches backwards to secure the stitch.

**TOP STITCH**

a continuous row of stitches on the right side of a garment as a decorative feature.

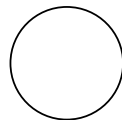

Right Side  
of Fabric

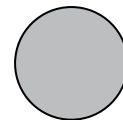

Wrong Side  
of Fabric

# WILLOW DRESS

## Instructions

### TIPS

Iron all seams once sewn to get a crisp finish.



### STEP ONE

#### *Dress Top Hem*

The first step in making the Willow Dress is to finish the top hem of our dress (piece #1). We don't want this to be too bulky, so we will do a double 5mm (0.5cm) fold to keep it minimal and neat.

Fold down 5mm, then another 5mm (0.5cm), then top stitch all the way along.

fold

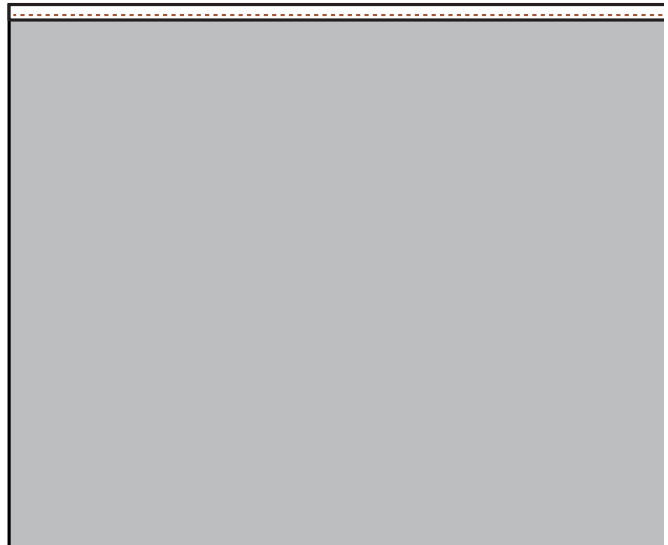

### STEP TWO

#### *Preparing our Binding Channels*

Our Binding Channels (pieces #2) are 3.5cm wide. We want to fold each side in 1cm, so that the finished piece is 1.5cm. Make sure to iron these really well so they stay in place.

Do this for all four (4) of the pattern piece #2's and put aside.



fold

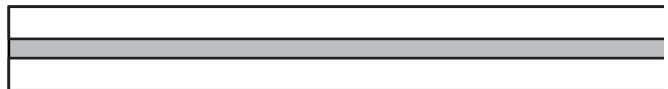

Wrong Side  
of Fabric



Right Side  
of Fabric

# WILLOW DRESS

## Instructions

### STEP THREE

#### *Attaching the First Binding Channel*

We will attach the first binding piece to the inside of our fabric (the wrong side) on the dress bodice (piece #1). Attach this 4cm down from the top hem of the dress.

Pin it in place so it is nice and straight all the way along. You want the folded sides on the underside hidden.

Leaving the two ends open, sew a row of top stitching along both the top and the bottom of the binding channel so it is fixed to the dress bodice all the way along. Sew as close to the edge of the binding channel as you can.

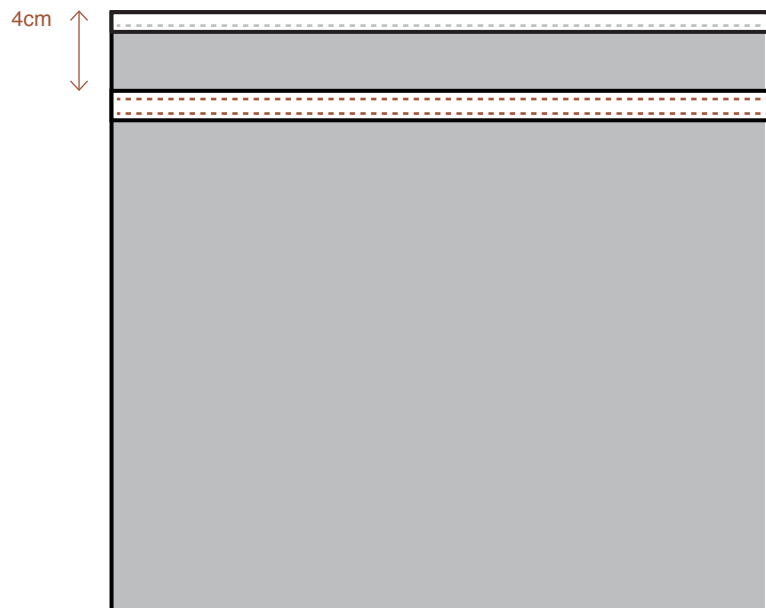

### STEP FOUR

#### *Attaching the Second Binding Channel*

We will use the same method to attach the second binding channel. Attach this 10cm down from the TOP of the first channel.

Make sure to attach this on the inside (wrong side) of your fabric.

#### **NOTE**

*You can change the placement of the binding channels based on your body. If you have a short torso - move the channels closer together. If you have a long torso - spread the channels out further apart.*

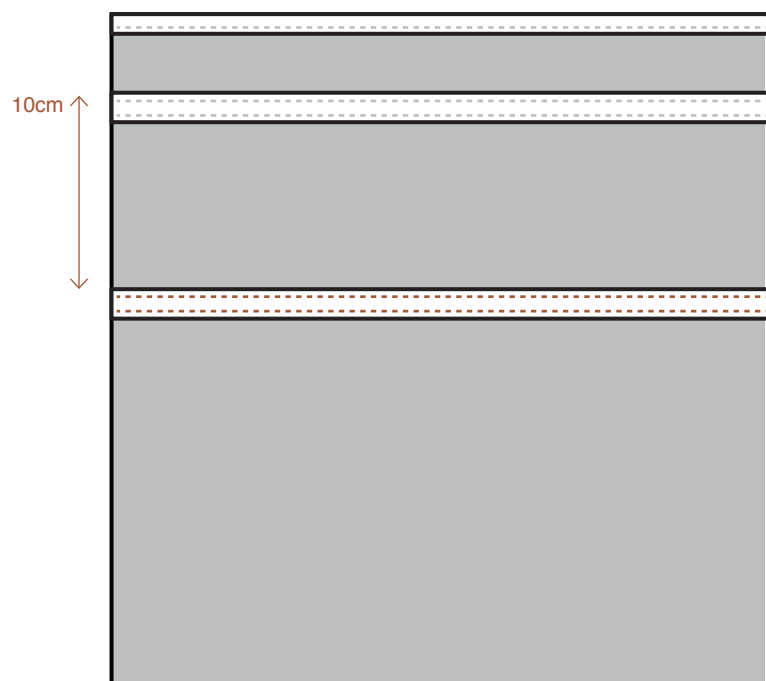

# WILLOW DRESS

## Instructions

### STEP FIVE

#### Attaching the Third Binding Channel

We will use the same method to attach the third binding channel. Attach this 7cm down from the TOP of the second channel.

Make sure to attach this on the inside (wrong side) of your fabric.

#### NOTE

*You can change the placement of the binding channels based on your body. If you have a short torso - move the channels closer together. If you have a long torso - spread the channels out further apart.*



### STEP SIX

#### Attaching the Fourth Binding Channel

This binding channel is attached differently as we won't be putting elastic through it. We will be attaching it on the outside (right side) of our fabric, and we will attach it in two sections.

Firstly mark the centre point on your dress bodice (piece #1). Cut your fourth binding channel in half so you have two equal pieces. Pin the binding channel pieces onto the dress bodice, with a 1cm gap in the centre of your dress, and 1cm in from either end.

Fold the raw ends in on each piece and attach this binding channel 7cm down from the TOP of the third channel.

Sew a row of top stitching along both the top and the bottom of the binding channels so they are fixed to the dress bodice all the way along. Sew as close to the edge of the binding channel as you can.

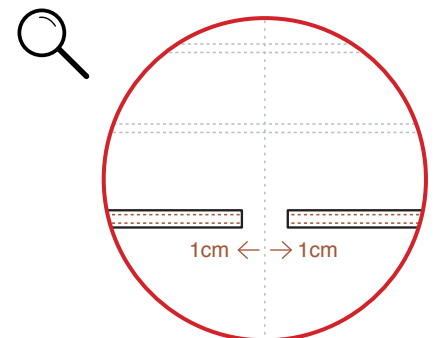
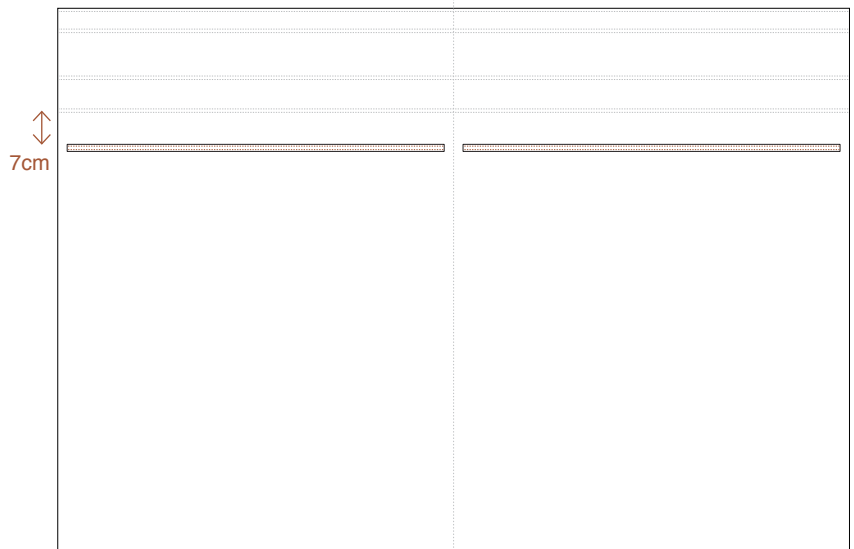



# WILLOW DRESS

## Instructions

### STEP SEVEN



#### *Hemming the Dress*

Yes, hemming before the end - revolutionary!

We are going to hem the dress the same way that we did the top hem - a double 5mm (0.5cm) hem.

Fold up 5mm, then another 5mm (0.5cm), then top stitch all the way along.



### STEP EIGHT



#### *Making the Shoulder Straps*

We are going to sew the binding straps similar to how you would make binding.

Fold each side in 1cm and iron.  
Then fold in half, so that all the exposed edges are hidden inside, iron this also.

To finish these off top stitch all the way along the entire strap.

If you are making the long shoulder straps to tie up, make sure to fold one end in for a neat finish to the end of the shoulder strap.

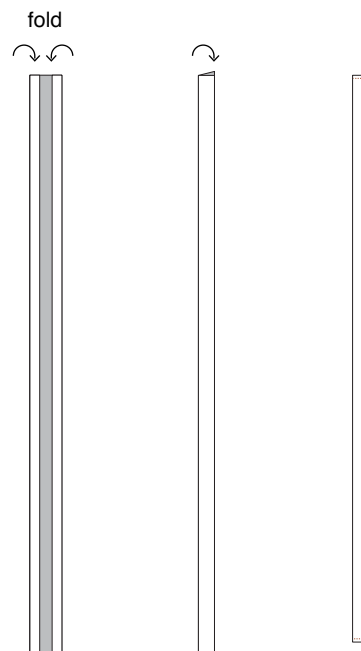

# WILLOW DRESS

## Instructions

### STEP NINE



#### *Making the Waist Ties*

We are going to make the waist ties exactly the same as the shoulder straps.

Fold each side in 1cm and iron. Then fold in half, so that all the exposed edges are hidden inside, iron this also. Make sure to fold in both ends so have a neat finish with no fraying.

To finish these off top stitch all the way along the entire waist tie.

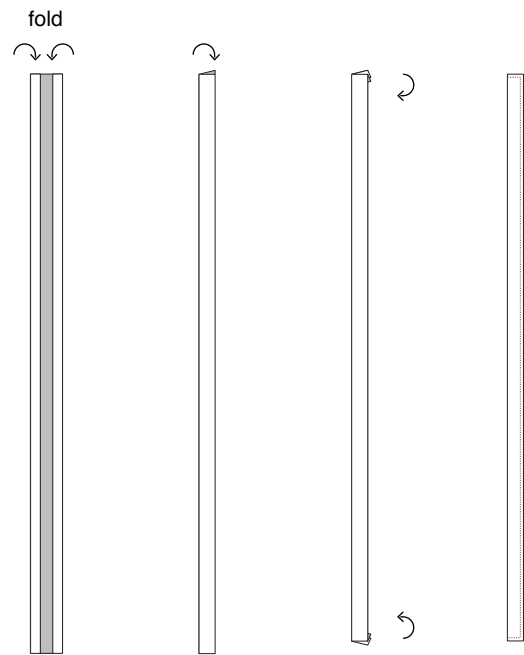

### STEP TEN

#### *Threading the Elastic Through*

Before we sew the dress together we are going to thread the elastic through the channels.

Measure the elastic around your body in the three areas the channels will be in - top, middle and base of your torso.

Start threading your elastic through each channel by using a safety pin. Make sure to secure it at the end so it doesn't pull through.

Once all elastic is threaded through, secure the ends in place by sewing over them a couple of times.

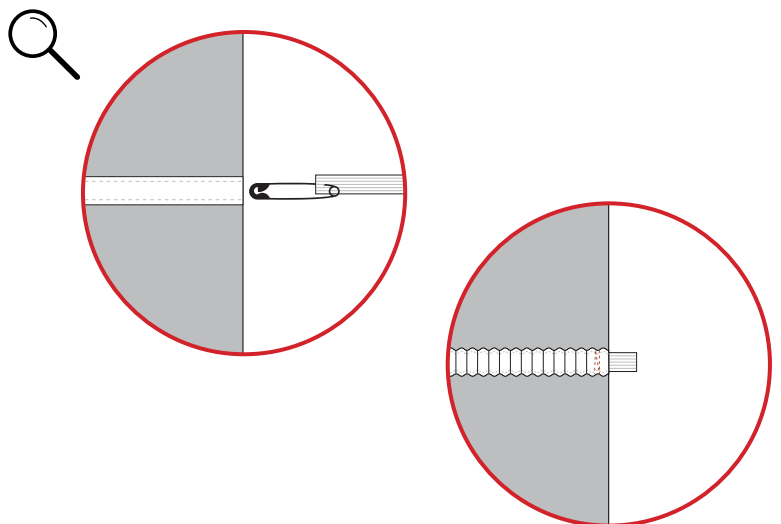
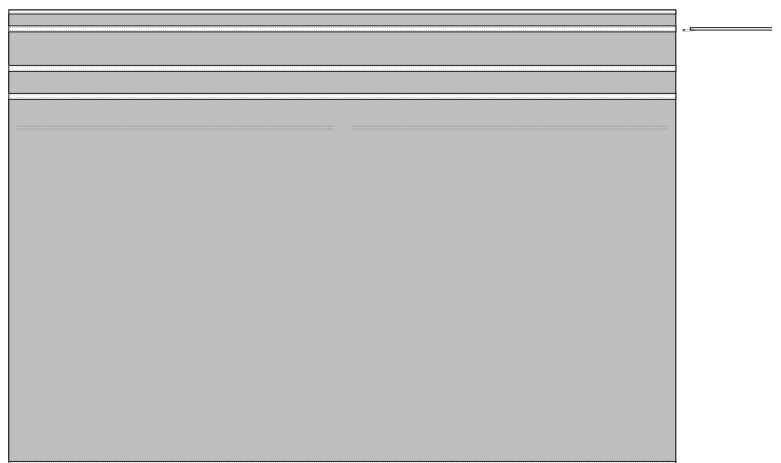

Wrong Side of Fabric



Right Side of Fabric

# WILLOW DRESS

## Instructions

### STEP ELEVEN

#### *Dress Side Seam*

Fold the entire dress in half, so that it forms a circle, keeping the right side of the fabric inwards (you want to sew the side seam on the inside (wrong side) so it is all hidden when you wear it). Line up the top hem and base hem and pin in place all the way down the side.

We are now going to sew all the way down the side, making sure to catch all the elastic ends in the process. You can finish this off with a zig-zag stitch or an overlocker to keep it neat and stop it fraying.

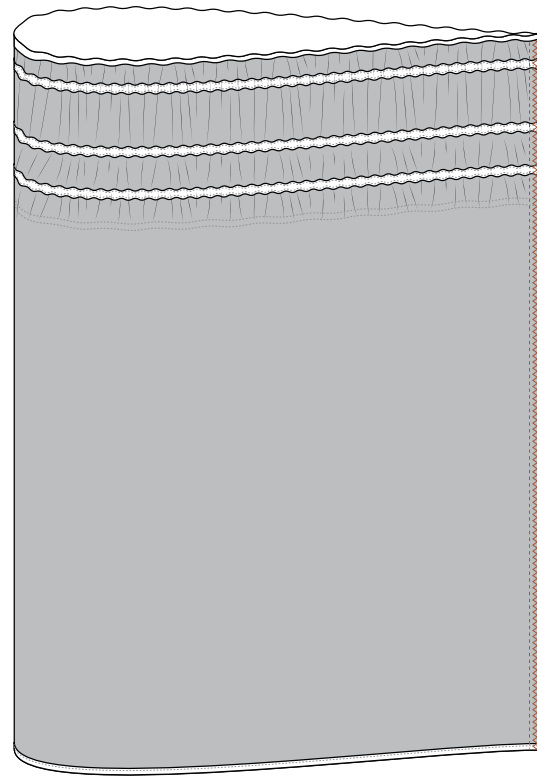

### STEP TWELVE

#### *Attaching the Shoulder Straps*

It is best to try your dress on at this point and mark where you want your shoulder straps to sit with a pin.

Make sure to attach the straps with a X pattern stitch, to ensure they are secure.

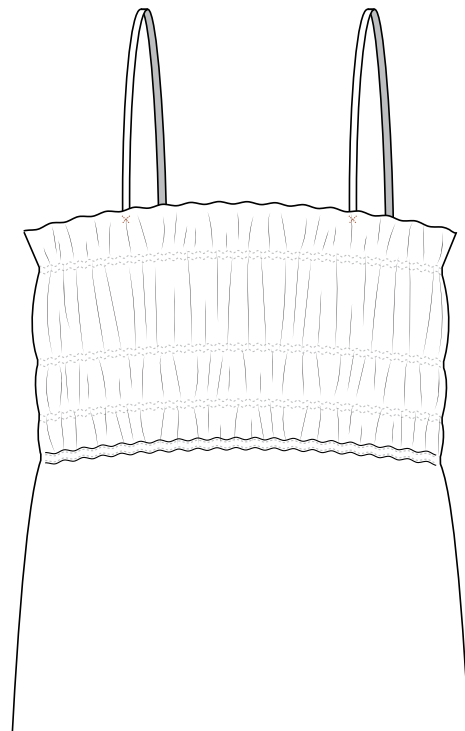

# WILLOW DRESS

## Instructions

### STEP THIRTEEN

#### *Threading through the Waist Ties*

The last step - hoorah!

Take one of your waist tie pieces and thread it through the front fourth channel, using a safety pin. Make sure it is evenly inserted so you have the same amount hanging out either end.

Take the remaining waist tie and thread it through the back fourth channel, using a safety pin. Making sure it is evenly inserted.

Pull both waist ties so that the dress gathers (similar to the elastic), and tie at both ends.

You will have to loosen these ties a bit to get the dress on, then tighten them and tie in a bow when wearing.

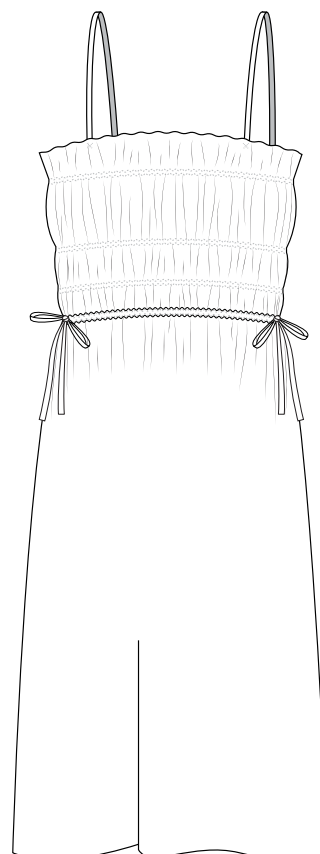
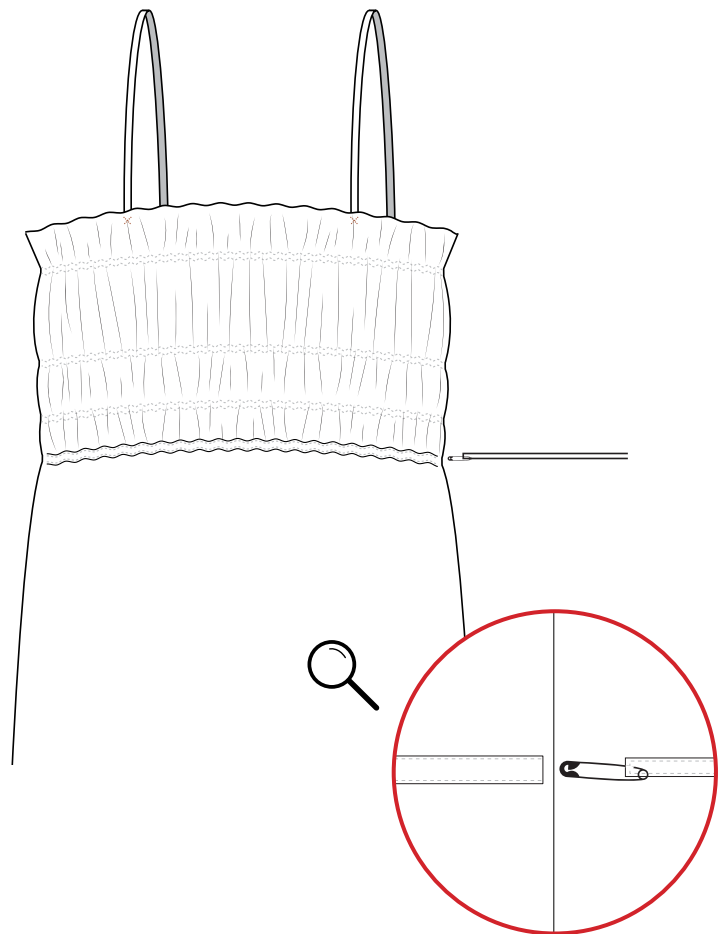

# Common Stitch.



**This pattern is for personal use only. Not to be used for commercial purposes.**

Use of this pattern entitles you to use the pattern for individual home use only.  
You can make the garment for yourself or as a gift.

It does not entitle you to print, copy or distribute the pattern to others, whether you profit from it or not, nor to sell garments that you have made from this sewing pattern.

Thank you for respecting the rights of the designer.

Copyright 2022 Common Stitch.

**common stitch.**

hand made in Australia

w: [www.commonstitch.com.au](http://www.commonstitch.com.au)  
e: [hello@commonstitch.com.au](mailto:hello@commonstitch.com.au)

 [common\\_stitch](https://www.instagram.com/common_stitch)