

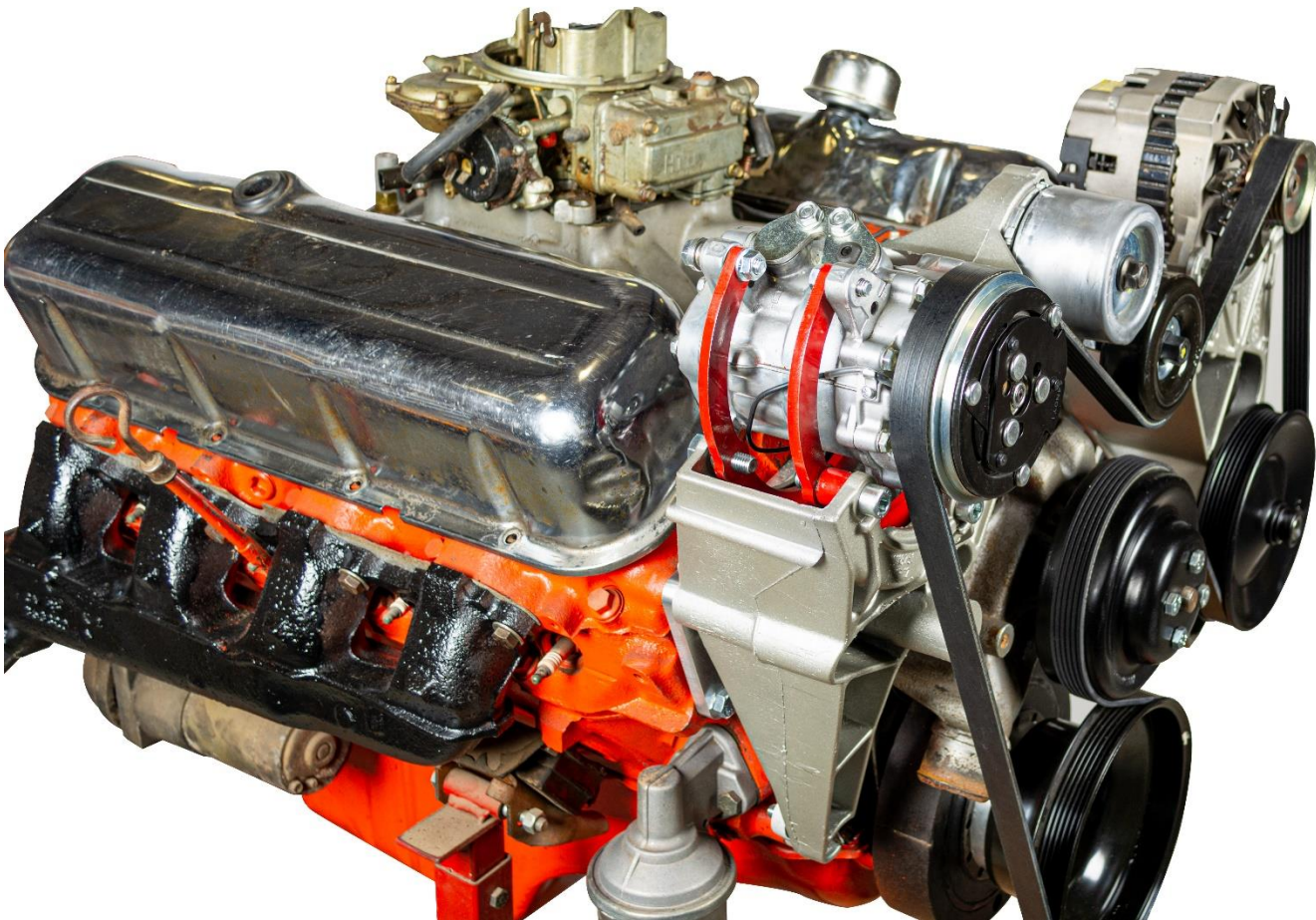

9683 N. Cedar Valley Lane  
Fair Grove, MO 65648  
417 955-1467 [www.kwikperf.com](http://www.kwikperf.com)

**K10606 R4 to Sanden 7176 Conversion**

**Installation Instructions**



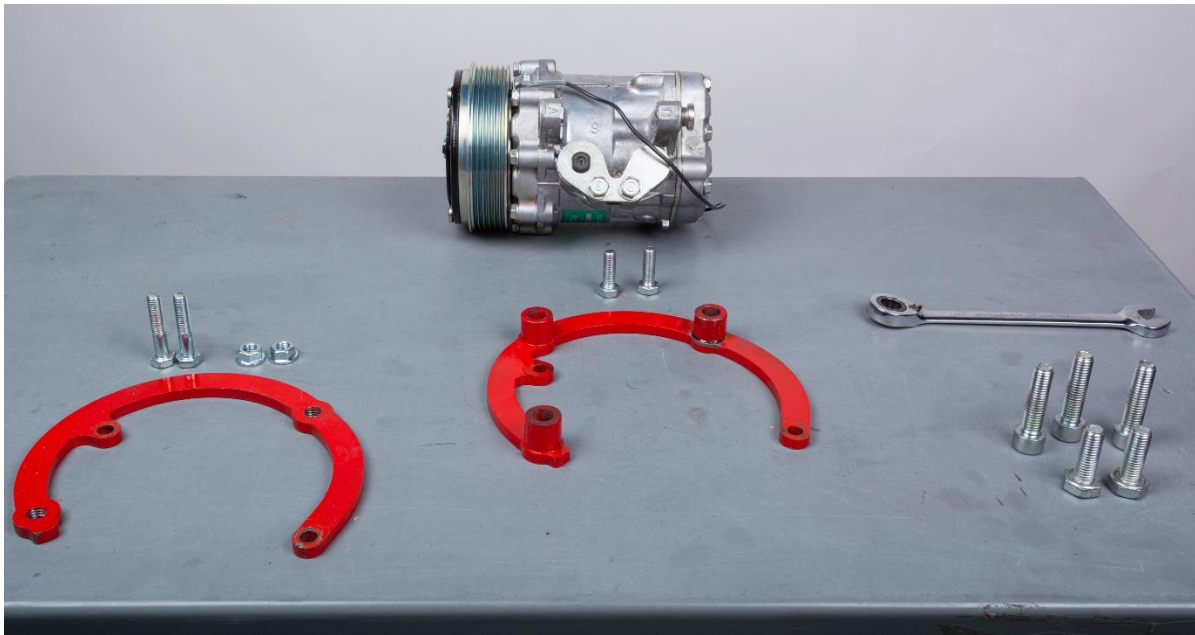

Items shown left to right. Rear plate, (2) 8x35mm bolts and nuts. Front Plate, (2) 8x25mm bolts. (3) 10mm socket head bolts to mount front plate to OEM bracket. (2) 10mm hex bolts to mount rear plate to OEM bracket

**Step 1.** Make sure rear sleeve of compressor is pushed out so that it is flush in the inside as shown.

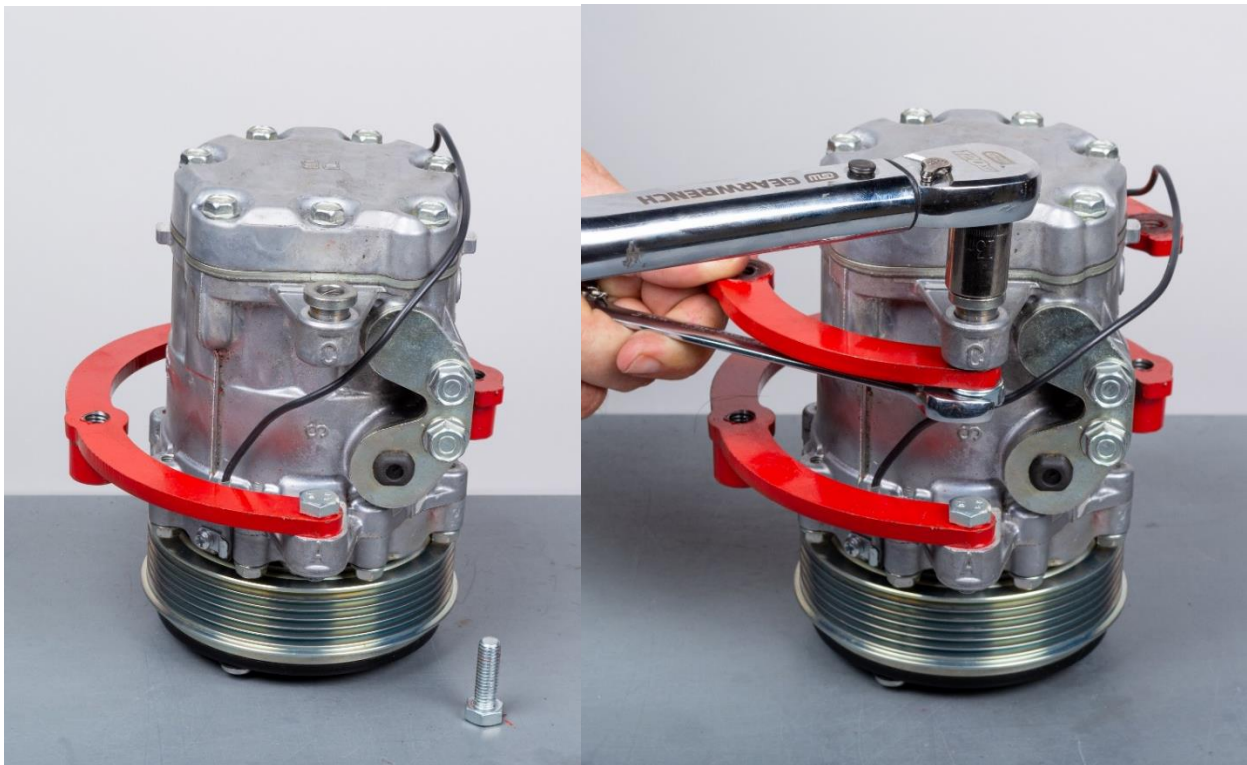

**Step 2.** Using 8x25mm bolts install front plate. Bushings will face toward compressor pulley. Torque to 15 ft lbs.

**Step 3.** Using 8x35mm bolts and nuts install the rear plate. Torque to 15 ft lbs.

### Install front ring on compressor

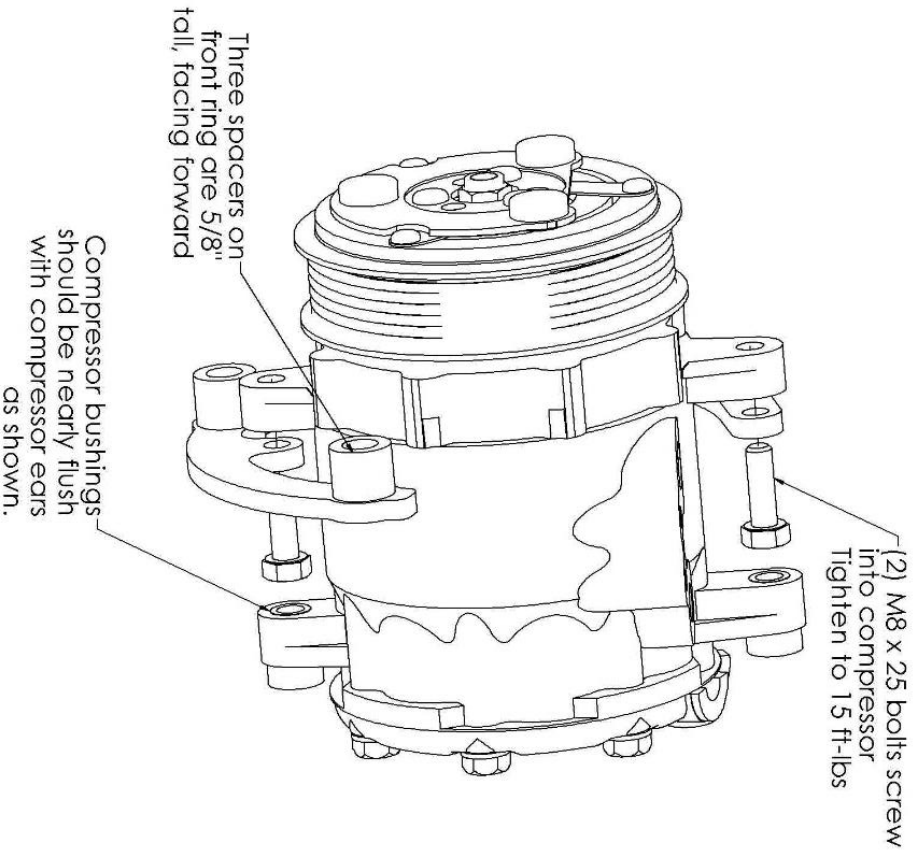

### Install rear ring on compressor

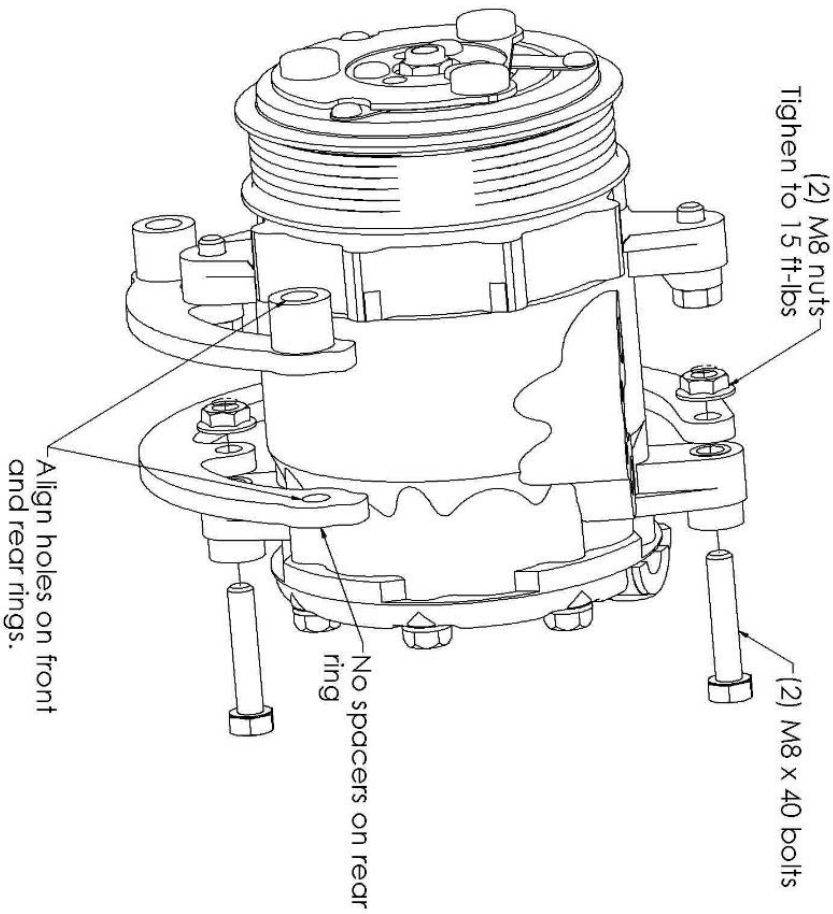

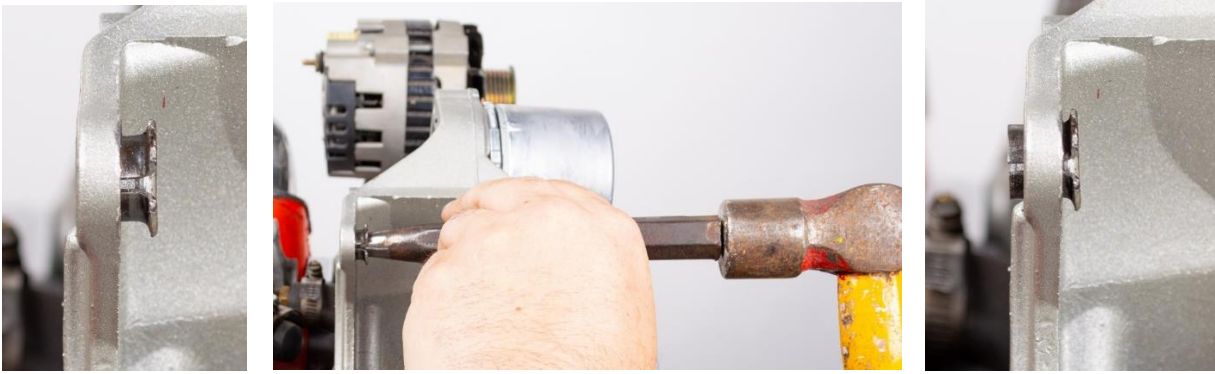

**Step 4. With a hammer and punch drive the split sleeves back. This allows the compressor assembly to be installed and squared to the front of the bracket without interference.**

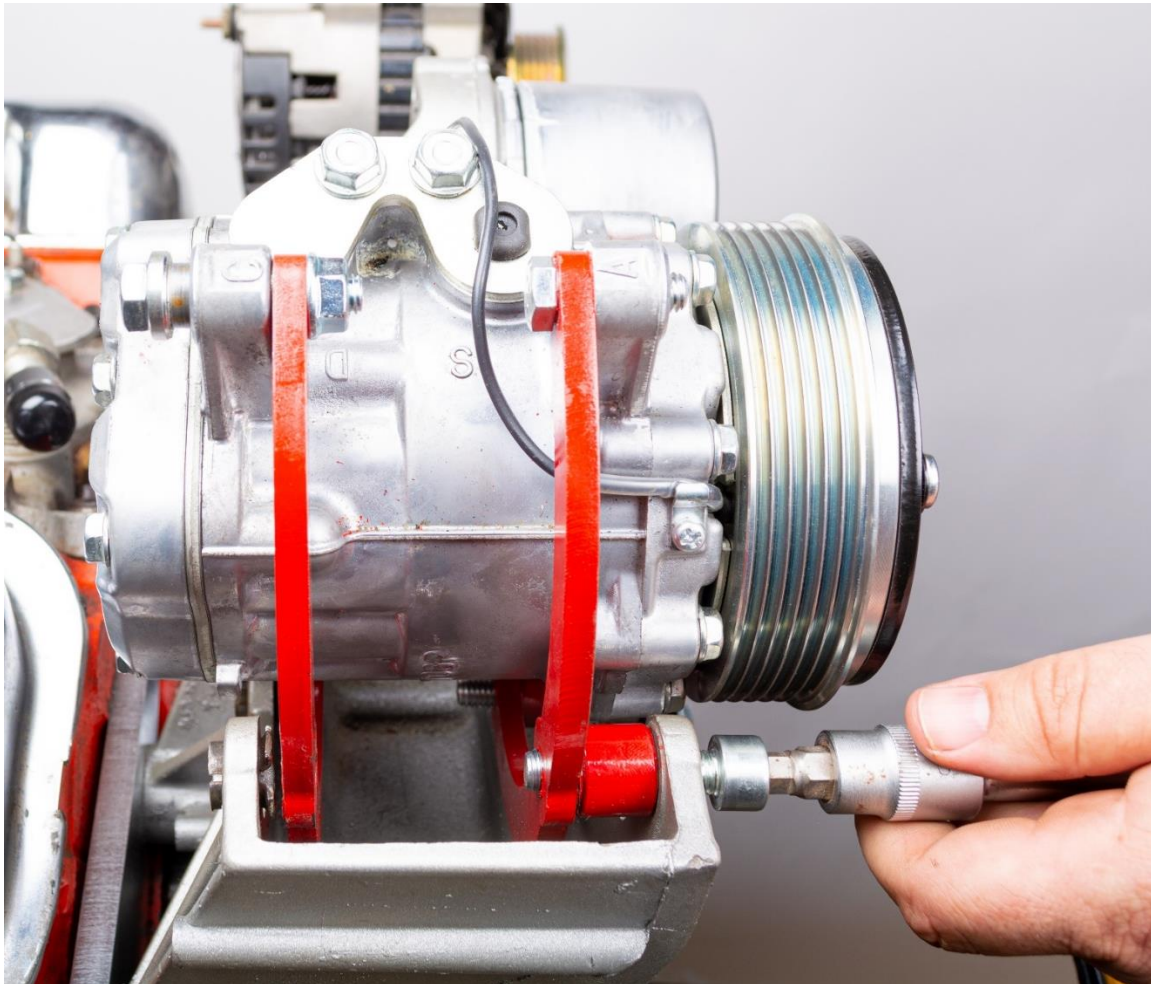

**Step 5. Install the compressor assembly with 10x35mm socket head bolts. Fully tighten (do not torque in this step).**

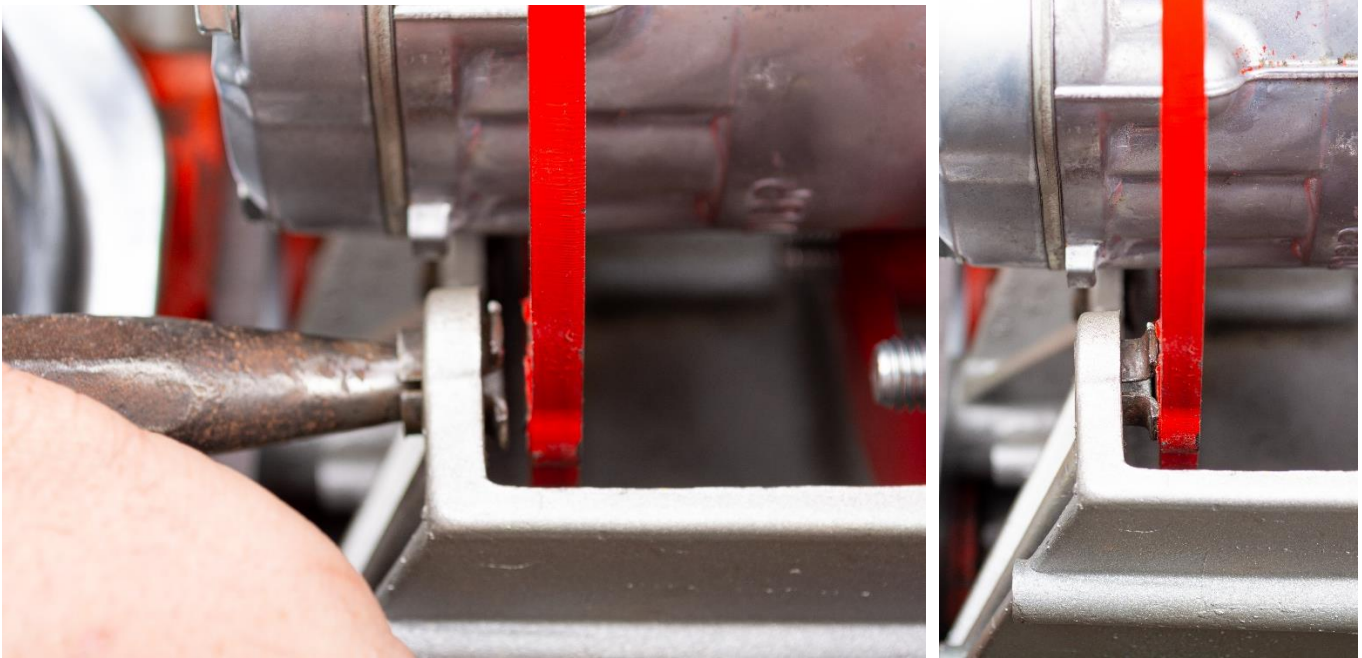

**Step 6. With hammer and punch, gently tap split sleeves until it mates with rear plate. Excessive force can overextend sleeve, possibly leading to misalignment. This does not have to be super precise, just pay attention to what you are doing.**

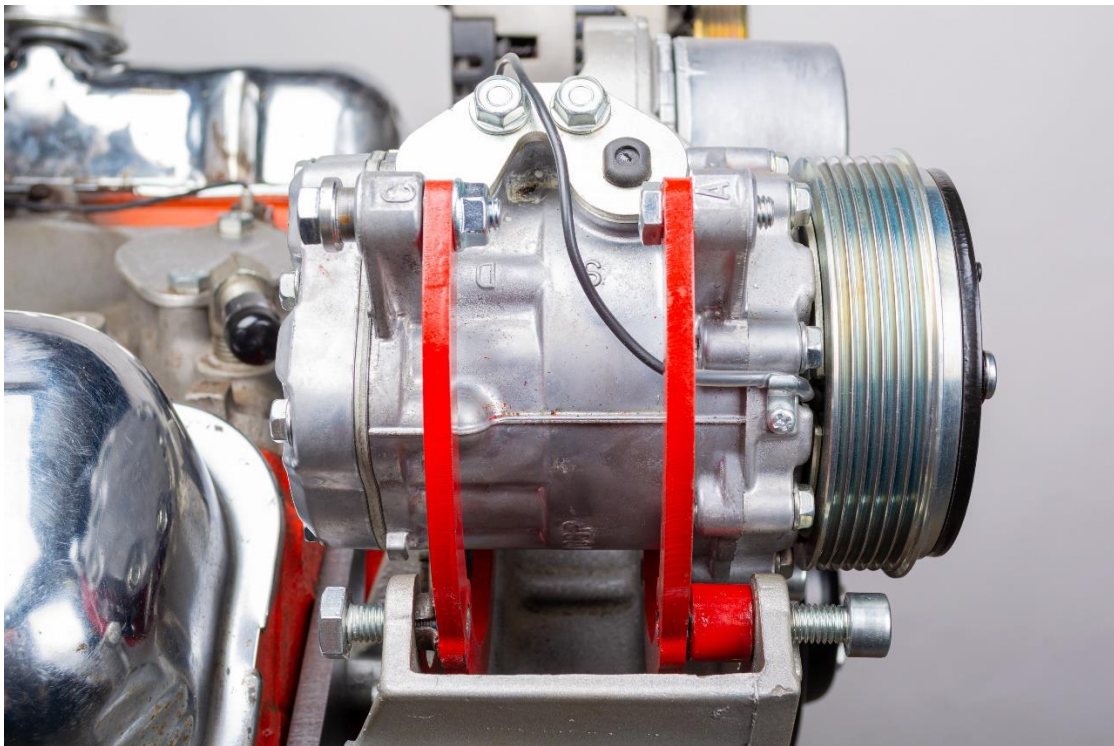

**Step 7. Loosen front socket bolts and install rear 10x30mm hex bolts.**

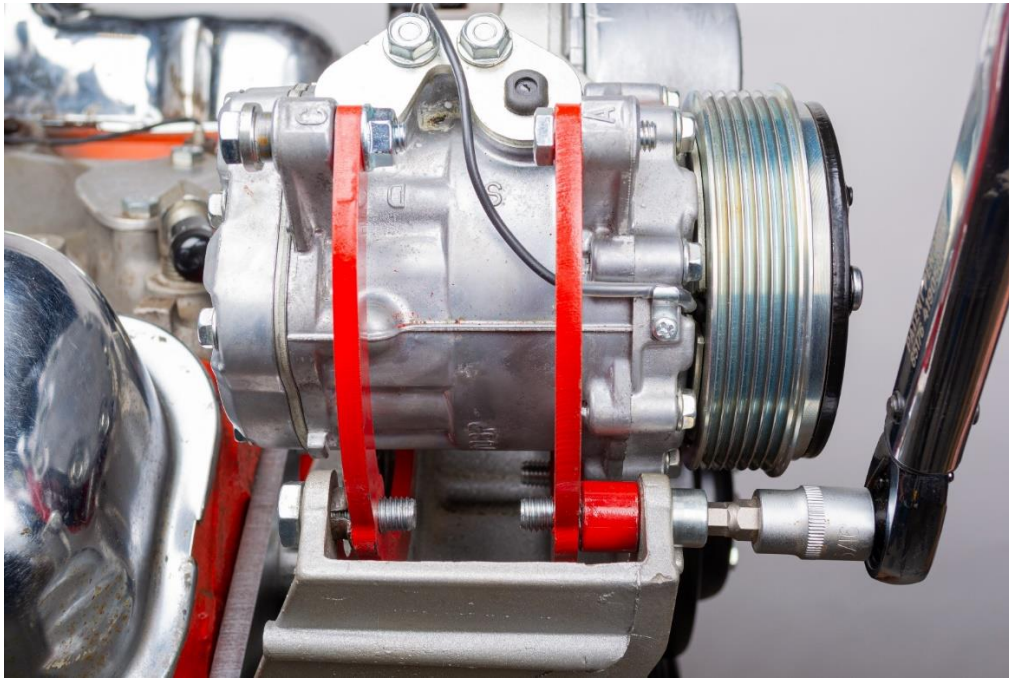

**Step 8. Beginning with the (3) socket head bolts in the front of the bracket, torque to 37 ft lbs. Followed by the (2) hex head bolts on the back of the bracket, also 37 ft lbs.**



**Step 9. Install belt. Suggested belt is Gates K060955. Verify tensioner is in the middle of its travel both after installation AND after initial startup. Longer or shorter belt may be required.**