

## Alternator-only Bracket Kit for LS1 Engines

### Kit contents:

- Front and rear attachment plates
- Spacer tubes
- 10mm bolts for mounting bracket to engine
- 10mm bolts and flange nuts for mounting alternator to bracket

Not included is a required six-rib belt, length such that the tensioner indicator arrow is between the max and min marks. See the following table for suggested belt lengths and Gates/Delco part numbers.

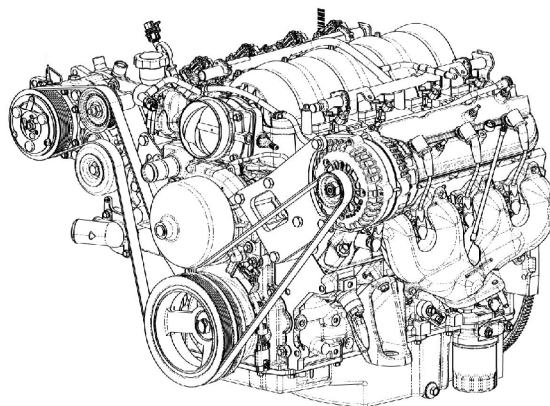

Belt using factory tensioner	Belt using Kwik Performance air conditioner bracket
71 1/2" – K060710	93 1/8" – K060926

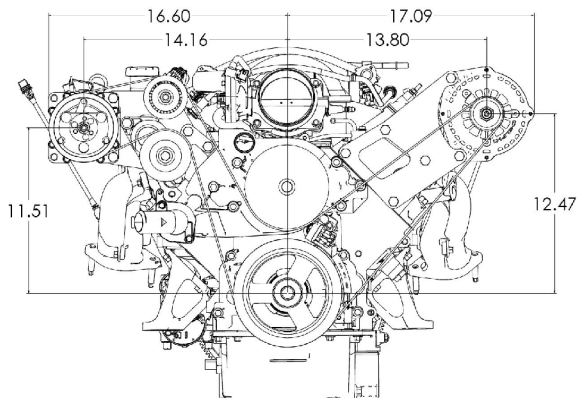
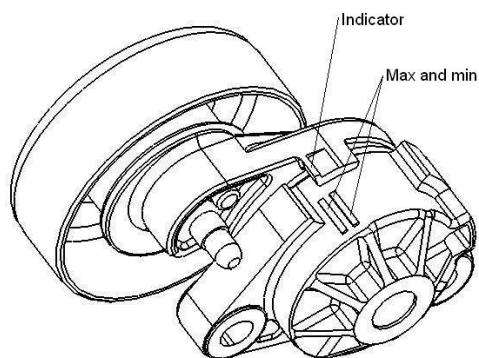

### Notes

- Leave all bolts loose until all parts are installed, then torque all 10mm bolts to 37 ft-lbs (50 N-m).

# Installation Instructions



## Alternator only bracket for LSx engines

### 1. Mount front plate to engine

10mm bolts screw  
into head:  
Corvette 80mm long  
Camaro 100mm long  
Truck 120mm long

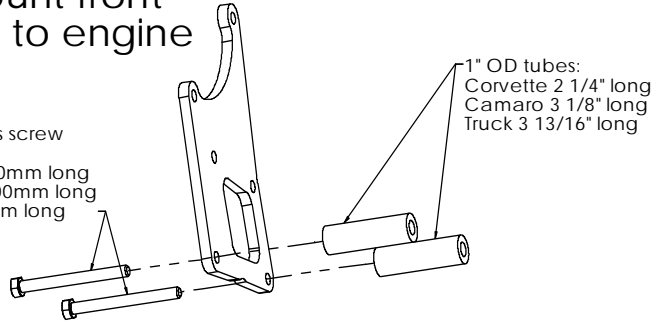

### 2. Mount rear plate to engine

10mm bolts screw  
into head:  
Corvette 80mm long  
Camaro 100mm long  
Truck 120mm long

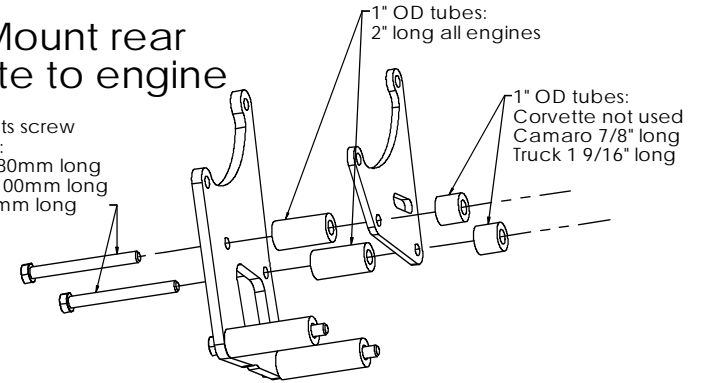

### 3. Mount alternator

10mm bolts  
80mm long  
all engines

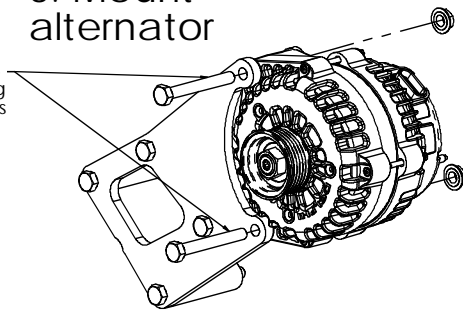

### 4. Torque all 10mm fasteners to 37 ft-lbs.