

Installation Instructions for K10166, K10167, & K10168

Alternator and power steering pump bracket for LS engines

Kit contents:

- Mounting plates
- Spacer tubes
- Fasteners
- Idler pulley

Additional parts required:

- Alternator
- Power steering pump with pulley
- Belt. See chart below.

Belt length and Gates PN - K10166, K10167, K10168 using factory belt tensioner		
Power steering pulley diameter	Belt using factory tensioner	Belt using Kwik Performance AC bracket
6.7"	79" - K060785	See AC bracket instructions
6.0"	78 5/8" - K060780	
5.5"	78" - K060775	

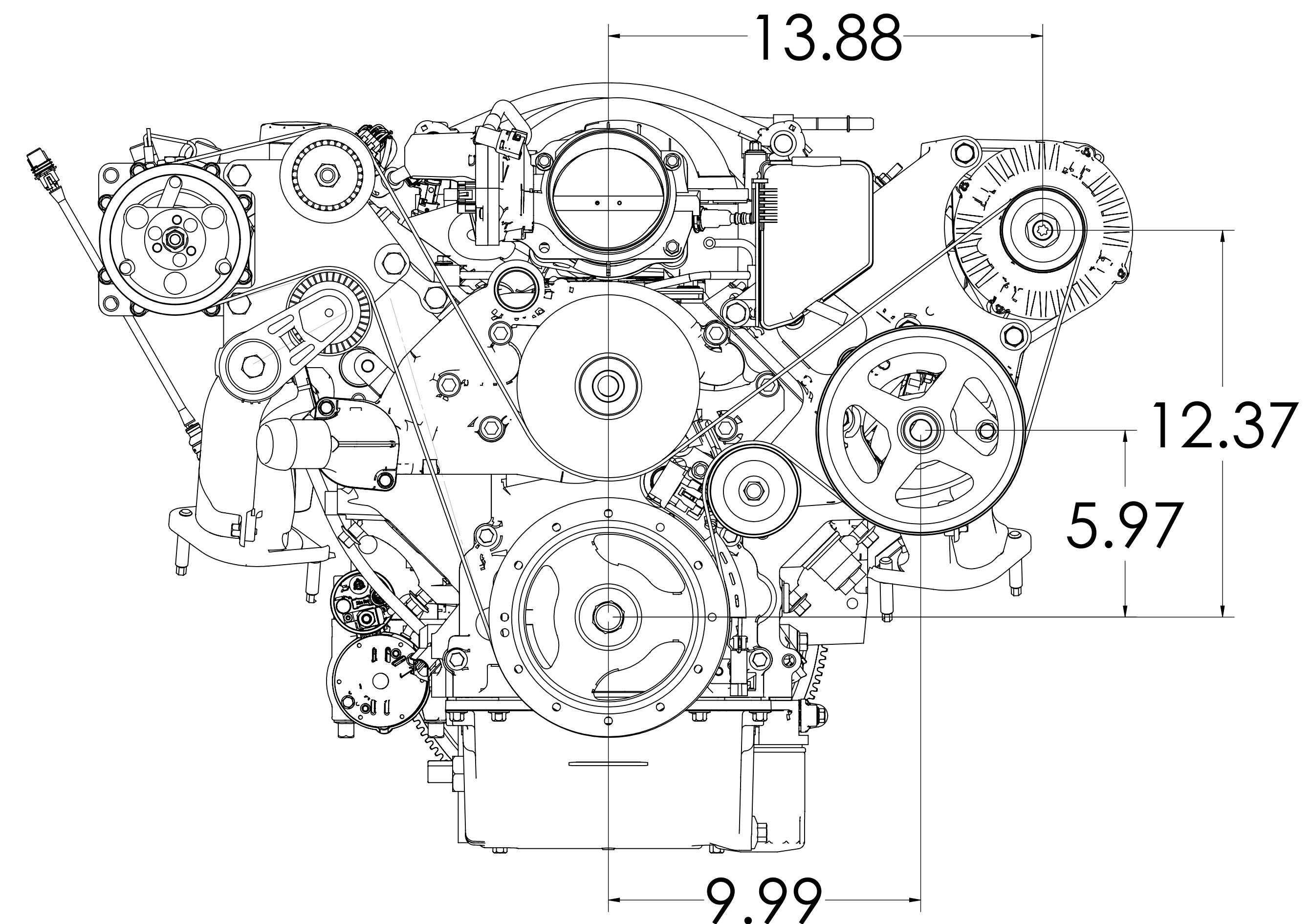

Belt installation
 With AC compressor

Installation Instructions for: K10166, K10167, & K10168 alternator and power steering pump bracket



Alternator and power steering pump bracket for LS engines

1. Assemble idler pulley.

**Note: Leave all fasteners
finger tight until step 5.**

Note that the 3 PS
pump spotfaces go
toward engine

12mm bolt and
flange nut

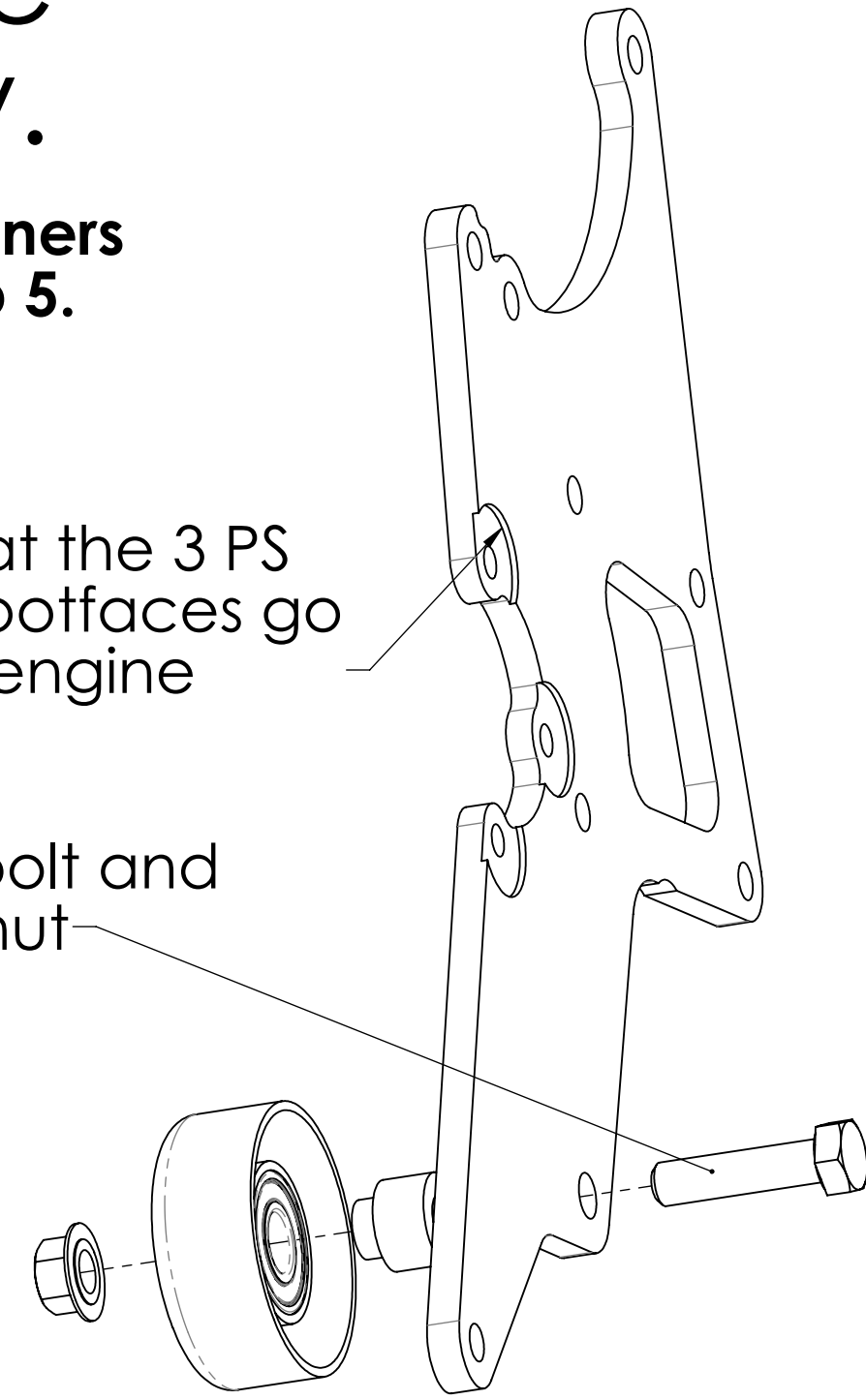

2. Mount front plate to engine

10mm bolts screw
into head:
Corvette 80mm long
Camaro 100mm long
Truck 120mm long

1" OD tubes:
Corvette 2 1/4" long
Camaro 3 1/8" long
Truck 3 13/16" long

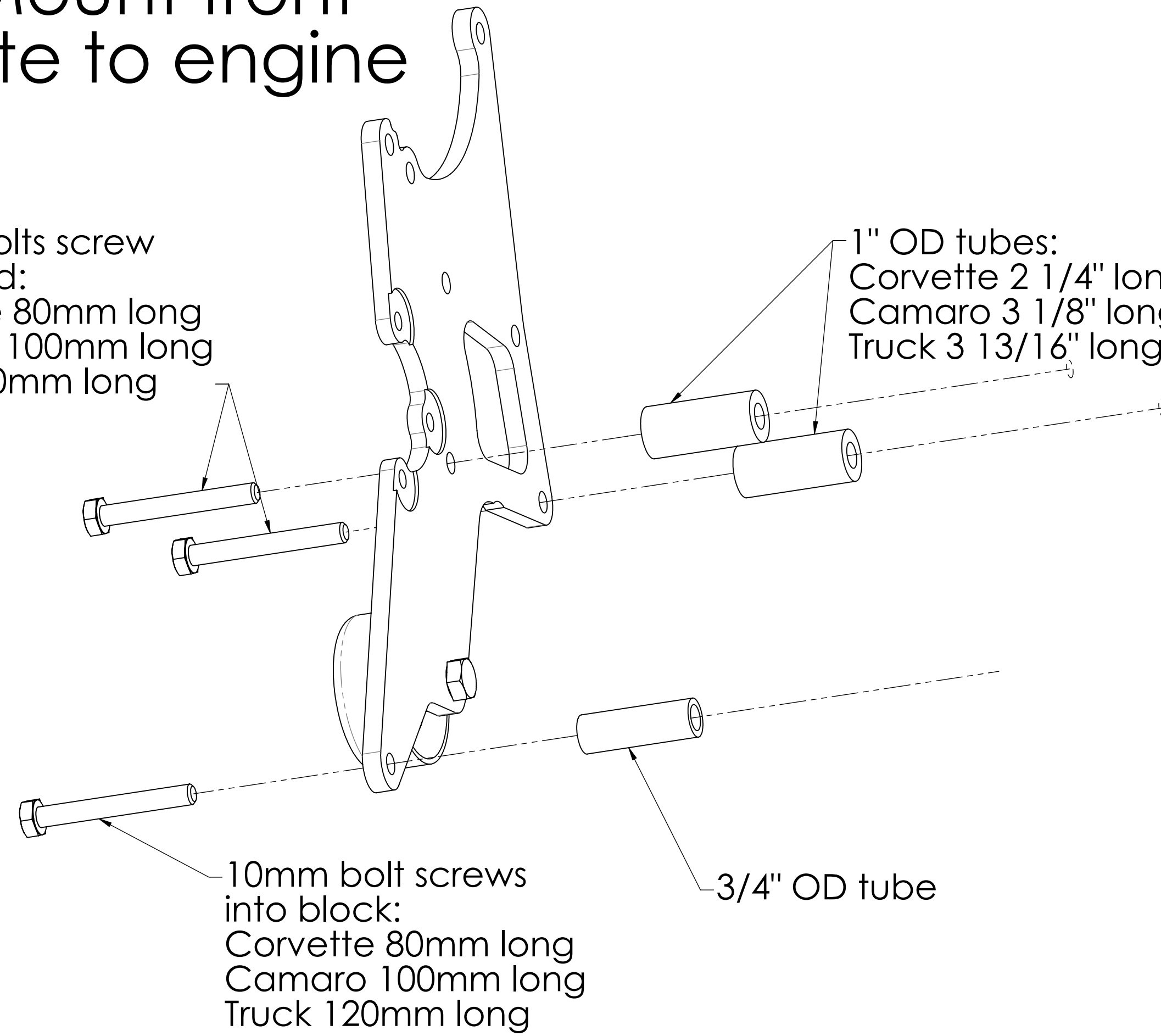

10mm bolt screws
into block:
Corvette 80mm long
Camaro 100mm long
Truck 120mm long

3/4" OD tube

3. Mount rear plate to engine

10mm bolts screw
into head:
Corvette 80mm long
Camaro 100mm long
Truck 120mm long

1" OD tubes:
2" long all engines

1" OD tubes:
Corvette not used
Camaro 7/8" long
Truck 1 9/16" long

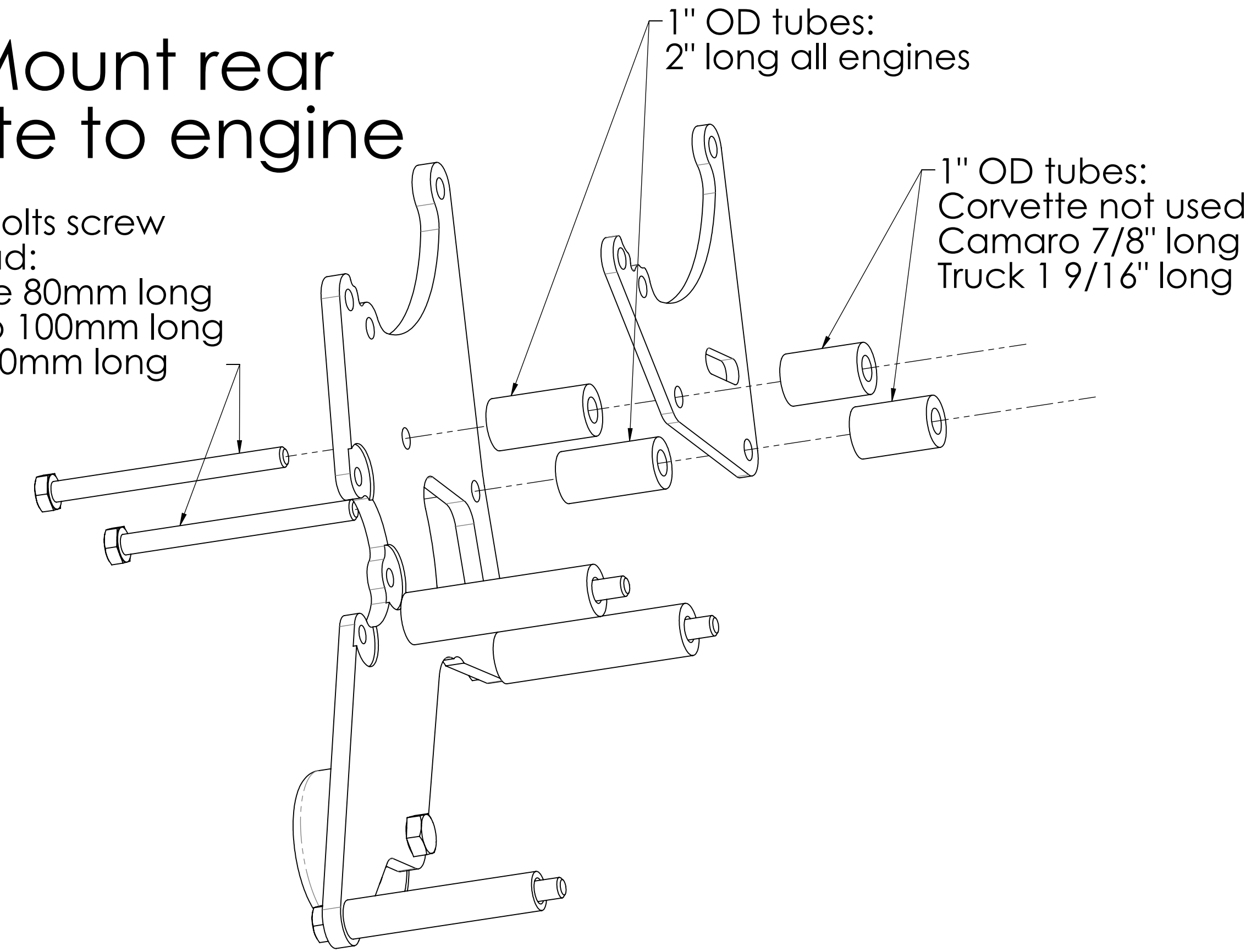

4. Mount alternator

10mm bolts
80mm long
all engines

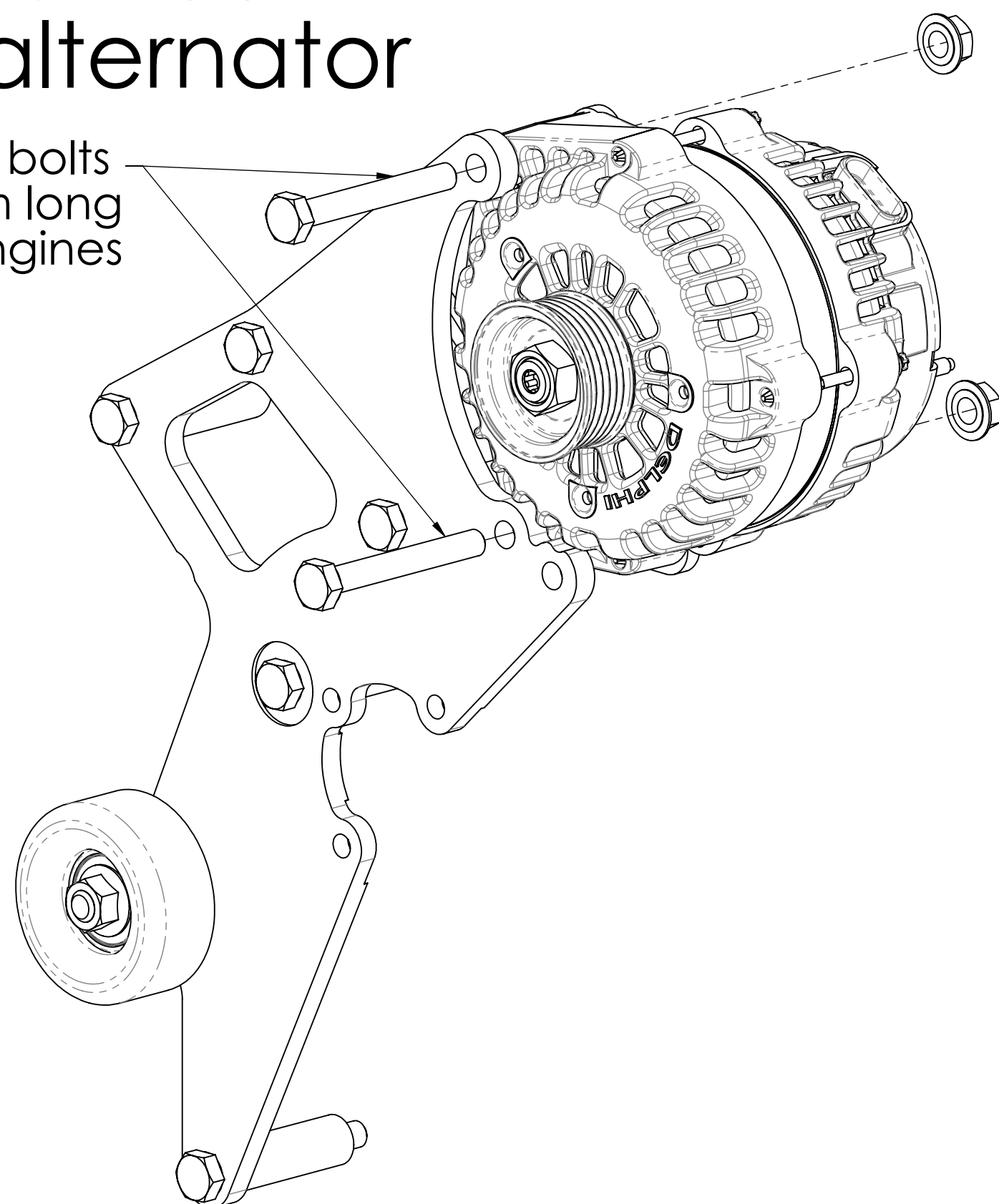

5. Torque fasteners:

12mm: 50 ft-lbs
10mm: 37 ft-lbs

6. Mount power steering pump

8 mm bolts
all engines
Torque to 15 ft-lbs

Extra bolts are
provided for
various pumps

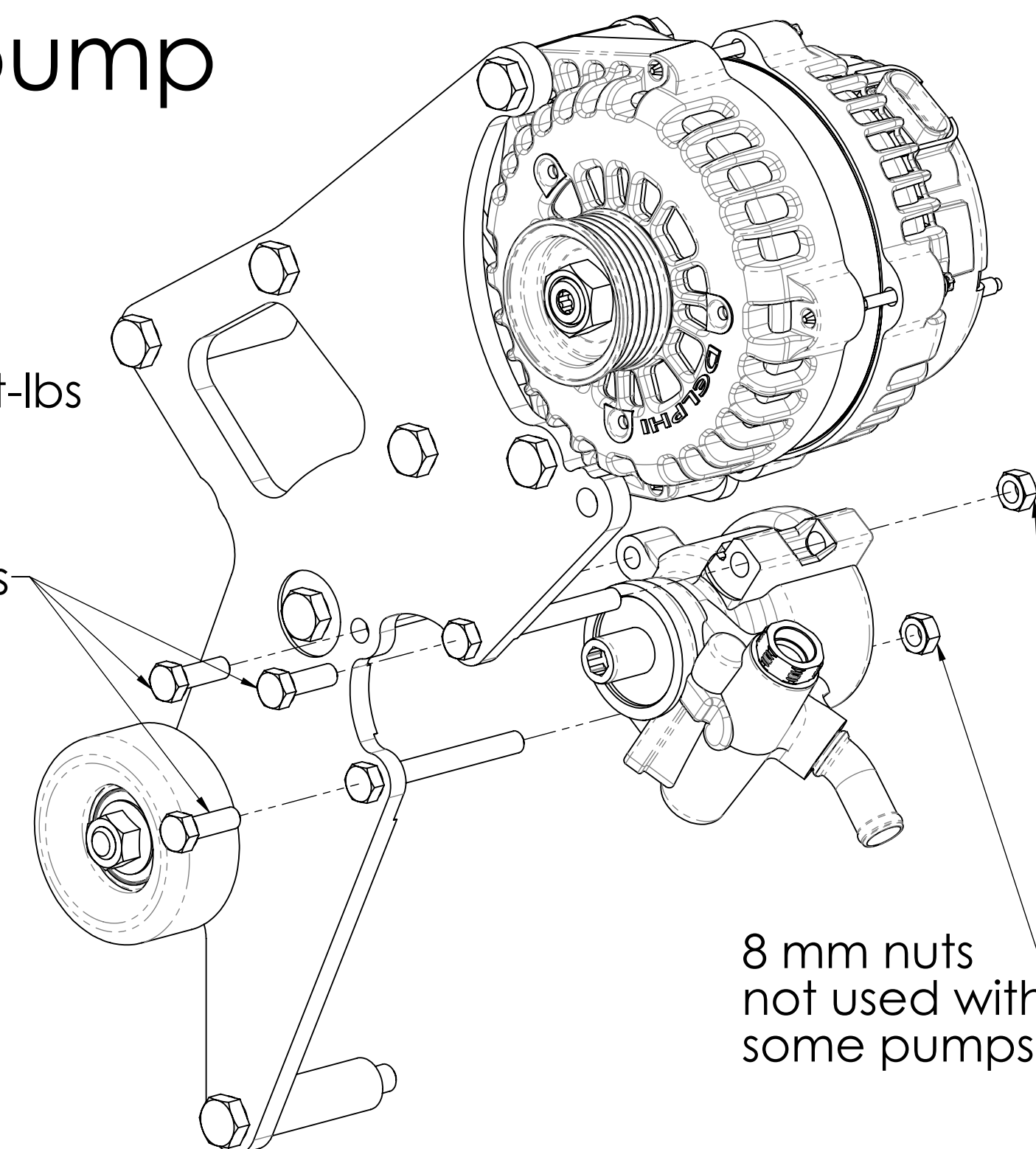

8 mm nuts
not used with
some pumps

7. Install power steering pulley.

Note: Some pulleys have windows in
them for access to 8mm bolts. Pulley and
pump can be installed as an assembly
after torquing all 10mm bolts.

Because of the wide variety of pumps
and pulleys that can be used, it may be
necessary to slide the pulley fore or aft
slightly on the pump shaft to align it with
the crank pulley. Pump/pulley assemblies
for a Gen 4 F-body engine will need an
adjustment.

Kwik Performance pumps come with the
pulley pre-installed in the correct
location and can be bolted on as is.