

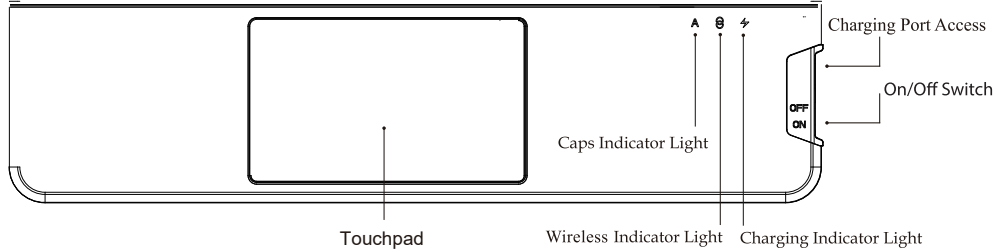

Bluetooth Keyboard Folio Case, with Trackpad - User Manual
 Fits iPad Pro 12.9" (Gen 4)
 Part: C30708518



Specifications:

Working Current	≤ 10mA	Working Voltage	3.0~4.2 V
Low Voltage Alert	3.0~3.3 V	Working Time	>70 Hours
Battery Standby Time	150 Days	Sleeping Current	<0.3mAh
Battery Lifetime	3 years	Battery Capacity	≤180 mA
Charging Port	TypeC USB	Keyboard Lifetime	<3 Million Strokes
Charging Time	2~3 Hours	Connect Distance	≤10 m
Awaken Time	≤ 2 Seconds	Charging Current	≤ 200 mA
Working Temperature	-10°C~55°C	Matching Password	Random

Indicator Light:

Caps Indicator Light	Uppercase when light is on Lowercase when light is off
Wireless Indicator Light	Press the "Fn+C" keys to pair the keyboard to the device. The light will turn off after successfully pairing.
Charging Indicator Light	Blinking Red - Low battery or device is charging Solid Green - Charging is complete

Function Keys

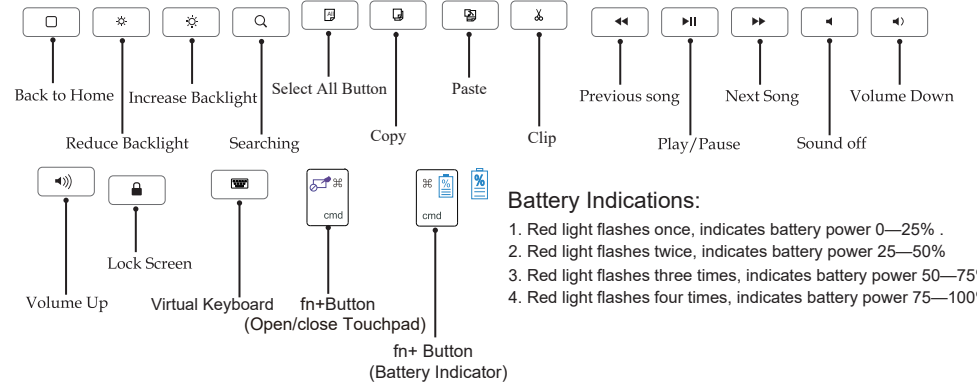

Battery Indications:

1. Red light flashes once, indicates battery power 0—25% .
2. Red light flashes twice, indicates battery power 25—50%
3. Red light flashes three times, indicates battery power 50—75%
4. Red light flashes four times, indicates battery power 75—100%

Operating Instructions

1. Install device, then open the cover, and use the stand on the rear of the case to prop up the device.
2. Turn on the keyboard by switching the On/Off switch to "ON"
3. Press "Fn+C" to pair your device with the keyboard
4. Open the Bluetooth settings on your device, and select "Wireless Keyboard".
5. Type the pairing code that shows on your device to complete the pairing process.
6. The keyboard is paired to your device, and ready to use

Maintenance & Warnings

1. Do not squeeze, distort, or bend the keyboard
2. Keep the keyboard away from magnetic fields
3. Keep the keyboard away from liquids - use in a dry environment
4. Use a soft cloth to clean your keyboard
5. Turn off the power, if the keyboard will not be used for a long period of time

Trouble Connecting?

1. Make sure your device and keyboard are both charged
2. Check to make sure your devices operating system is up to date
3. Turn off the keyboard
4. Turn off Bluetooth on your device
5. Turn on the keyboard
6. Turn on the Bluetooth on your device and try to repair
7. If you still experience any issues, please contact CODI customer support at customersupport@codiworldwide.com

Trackpad Gestures

Trackpad function	Finger action image	Finger action	Trackpad function	Finger action image	Finger action
Click		Press with one finger until you feel a click.	Scroll left or right		Swipe two fingers left or right.
Click and hold		Press and hold with one finger	Scroll up or down		Swipe two fingers up or down.
Go Home		Use one finger to swipe the pointer past the bottom of the screen. After the Dock appears, swipe the pointer past the bottom of the screen again.	Go Home		Swipe up with three fingers.
View Slide Over		Use one finger to swipe the pointer past the right edge of the screen. To hide Slide Over, swipe right again.	Zoom		Place two fingers near each other. Pinch open to zoom in, or pinch closed to zoom out.
Drag		Click and hold an item, then slide your finger across the trackpad to move it.	Open Today View		When the Home screen or the Lock screen is visible, use two fingers to swipe right.
Wake iPad		Click the trackpad. Or, if you're using an external keyboard, press any key.	Secondary click		Click with two fingers to show the quick actions menu for items like icons on the Home screen, messages in a mailbox, and the Camera button in Control Center.
Go Home		Use one finger to swipe the pointer past the bottom of the screen. After the Dock appears, swipe the pointer past the bottom of the screen again.	Switch between open apps		Swipe left or right with three fingers.
Open Control Center		Use one finger to move the pointer to select the status icons at the top right, then click.	Open search from the Home screen		Swipe down with two fingers.
Open Notification Center		Use one finger to move the pointer past the top of the screen near the middle.			

How to use the stand

