

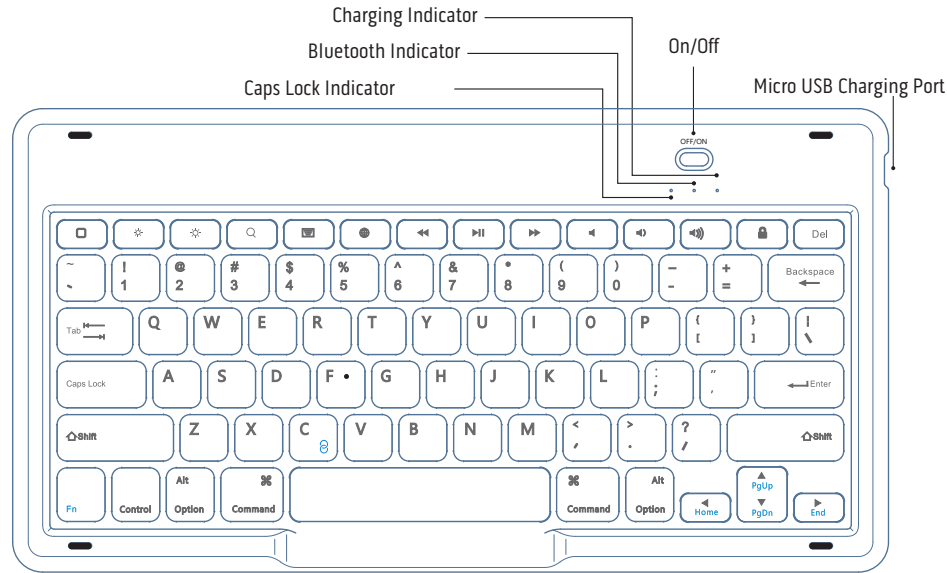

# Bluetooth Keyboard User Manual



## SPECIFICATIONS

Working Current	≤ 3.0 mA	Working Voltage	3.0~4.2 V
Low Voltage Alert	3.0~3.3 V	Working Time	>70 Hours
Battery Standby Time	150 Days	Sleep Current	<0.3mAh
Battery Lifetime	3 Years	Battery Capacity	≤180 mA
Charging Port	Micro USB	Wake Time	≤ 2 Seconds
Charging Time	3~5 Hours	Range	≤ 30 Feet
Working Temperature	15F ~130F	Charging Current	≤ 200 mA

## FUNCTION KEYS

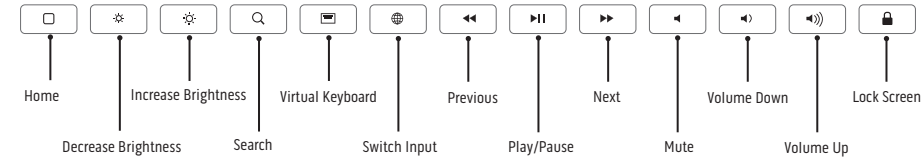

## BLUETOOTH CONNECTIVITY STEPS

1. Your CODi Bluetooth Keyboard Case will have a partial charge, when first removed from it's packaging.
2. Prior to pairing with your iPad, charge the Bluetooth Keyboard Case until it has a full battery
3. When it's fully charged, a solid green light will show next to "Batt", on the keyboard.
4. Check to make sure your iPad's IOS is updated to the latest version
5. Enable Bluetooth on your iPad (Settings -> Bluetooth -> "On")
6. Turn on the keyboard
7. Begin pairing with your iPad by holding the function key (Fn) and pressing the "C" key, with the Bluetooth icon
8. A blue LED light will begin flashing
9. In your iPad Bluetooth Settings, "Bluetooth Keyboard" will appear under "Other Devices"
10. Choose "Bluetooth Keyboard"
11. You will be prompted to enter a 4-Digit passcode.
12. Pairing will complete, and you will see "Bluetooth Keyboard" under "My Devices", with "Connected", next to it.