



A brand of ENSUPRA LLC

19840 FM 1093, Suite: G-018

RICHMOND, TX 77407

Tel: 800.823.9786

E-mail: info@plugged solar.com

5KW Roof Installation Manual

Include Elements:

- Solar PV Panels: Total 5KW: Typical solar panels are 310Watts, size 5.5ft x 3.3ft. 16PCS
- Unirac™ roof installation parts.
- SMA Grid-Tie Inverter 5KW or Similar top brand, approved by utility
- DC wire with MC4 connectors & AC wire.
- AC Disconnect as per utility

Installation Steps

1. Using Unirac Universal PV Module Roof Mounts installation booklet, install the roof mount system in your roof and secure the panels.

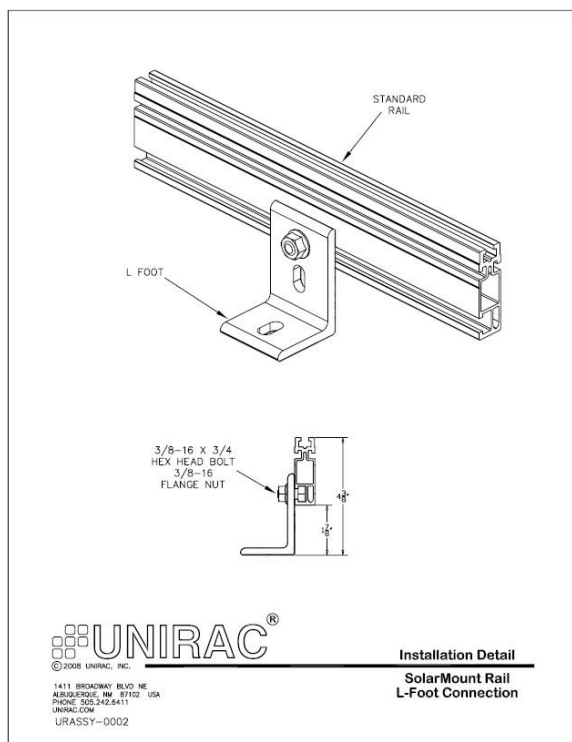

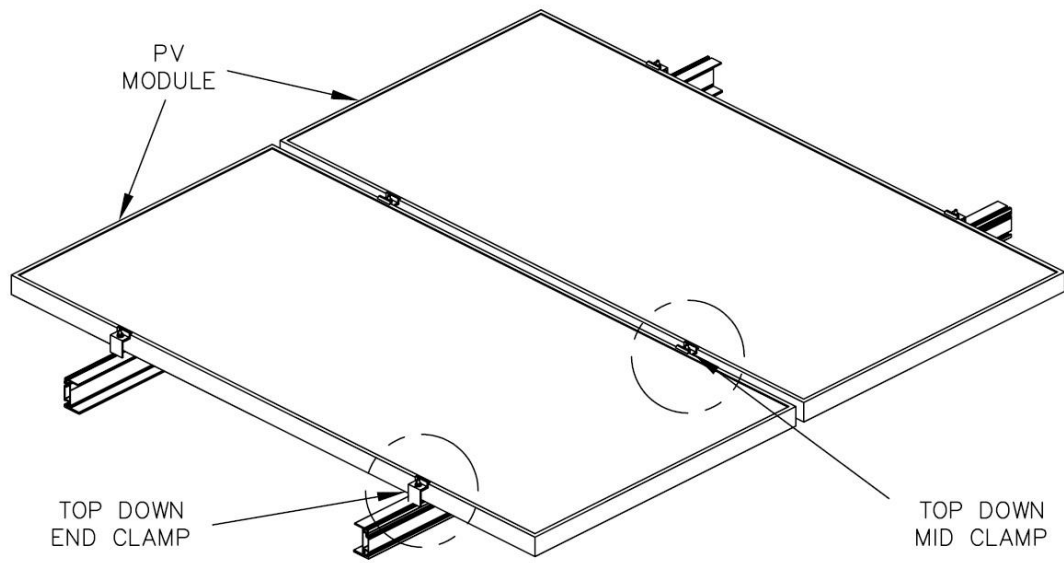

2. Attach the 10gauge ground wire (not provided and can be bought from local store) to the rail.



3. Attach the 10gauge ground wire (not provided and can be bought from local store) to the rail.

8. Wires from the AC side of the inverter go to one of the available 240V AC circuit breaker (min 25Amp). If there is none available, you may buy one circuit breaker from the local hardware store and put into a vacant slot of the electric box. It is highly recommended to get a professional electrician to do the 240VAC work.
9. Turn on the breaker, wait 6 minutes for the Plugged Solar System to start and check the Monitor display.

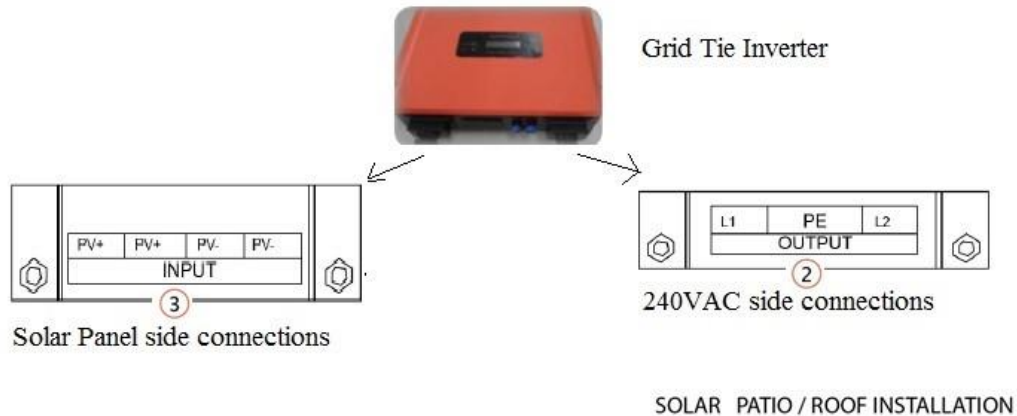

- ① Solar Panel
- ② Inverter box
- ③ DC Cable
- ④ Roof Racking
- ⑤ Ground Cable
- ⑥ Main Elec.Box

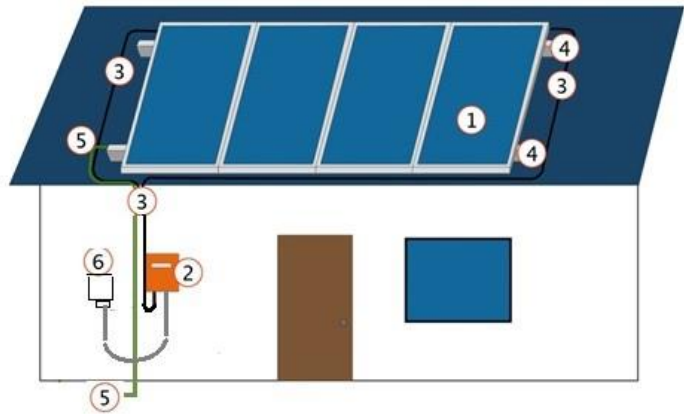

10. Start saving money on electricity by using Plugged Solar™.

If you want ground mount system, please contact us for ground mount additional racking.

www.PluggedSolar.com Tel: 800.823.9786 E-mail: info@plugged solar.com