

limber

Desk

Dimensional Illustrations

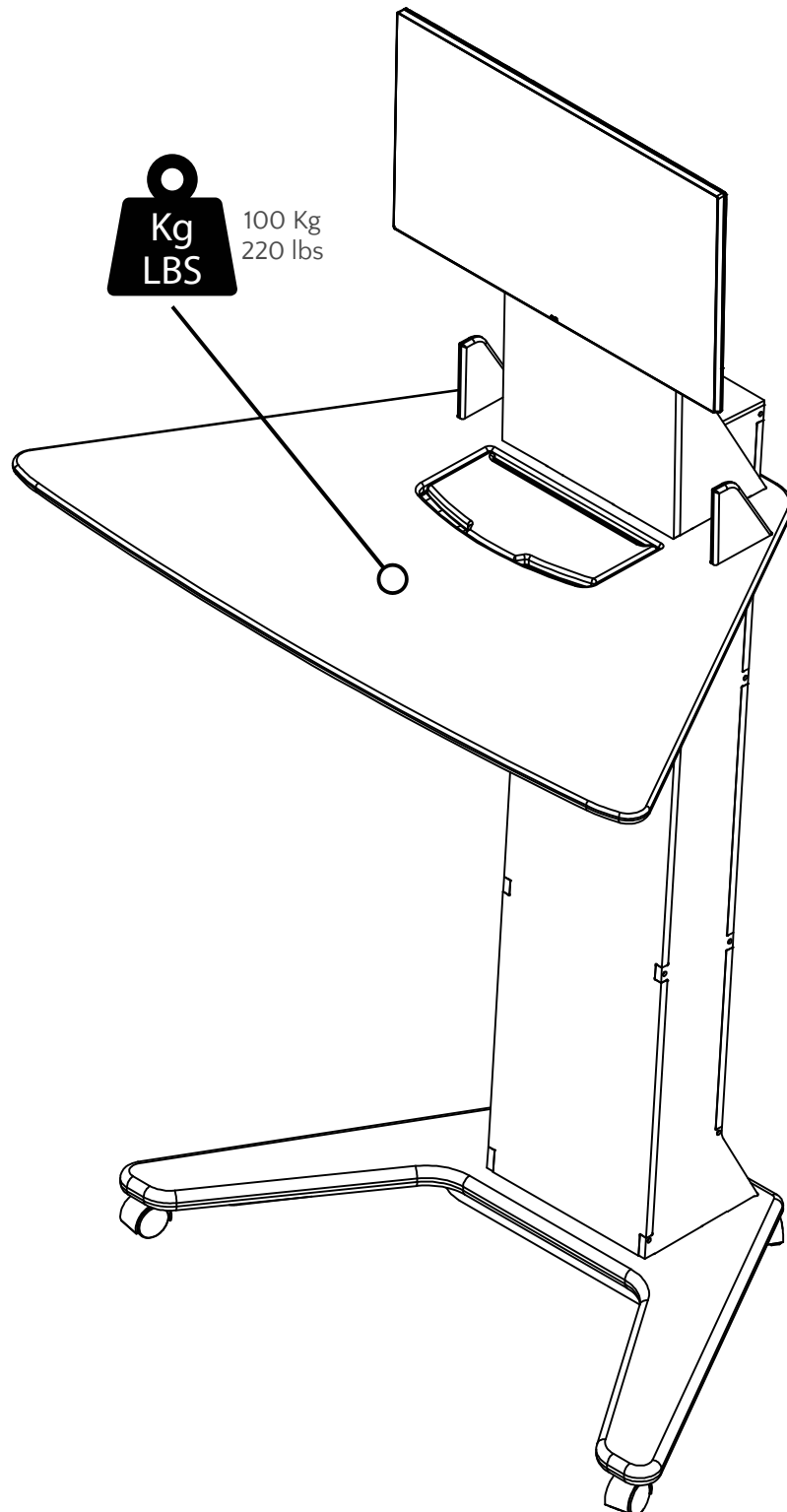

V3 2021-11-24

Content is subject to change without notification

© 2021 Limber Ltd 39 Gloucester Street, Wilton, Wellington 6012



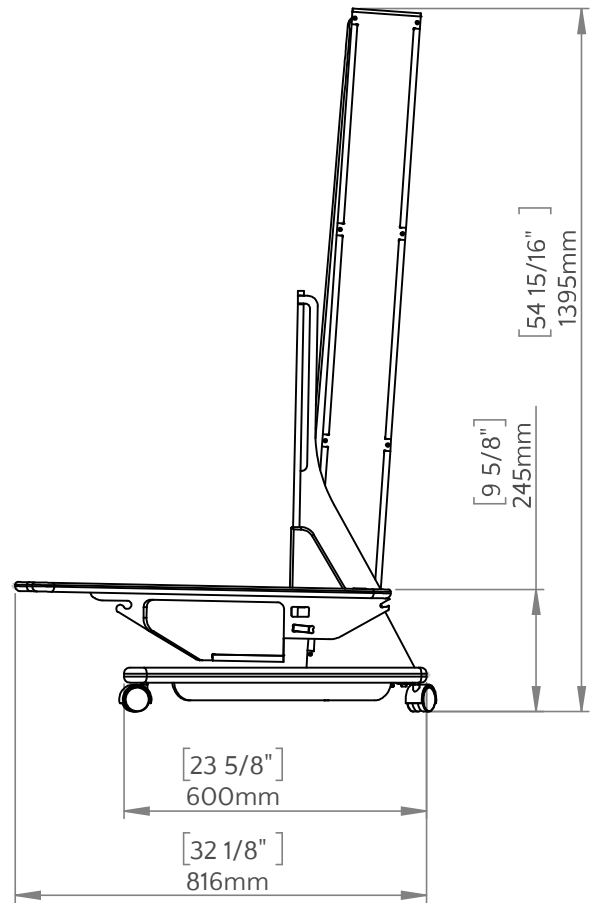
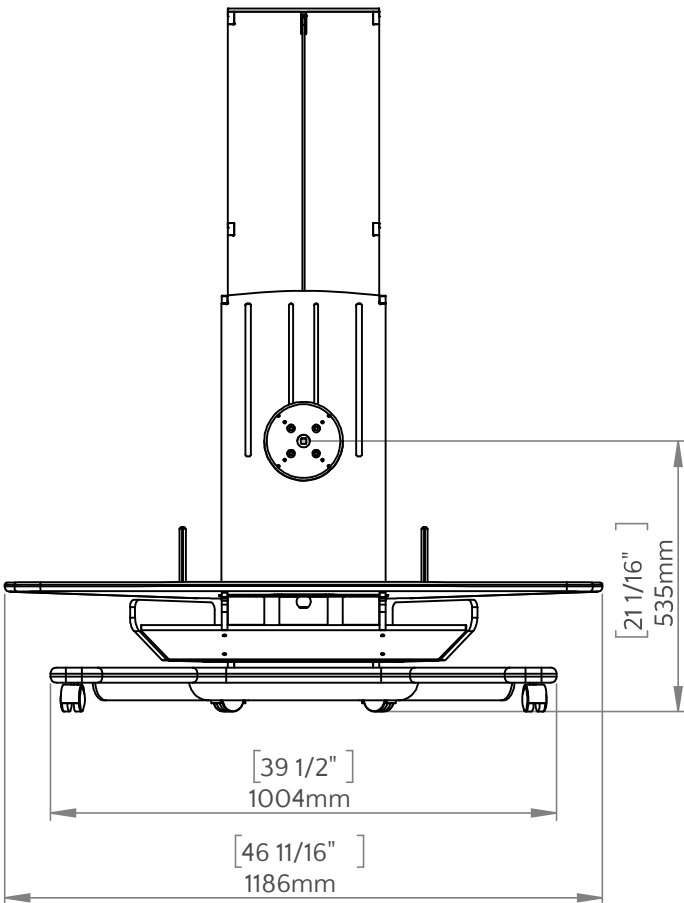
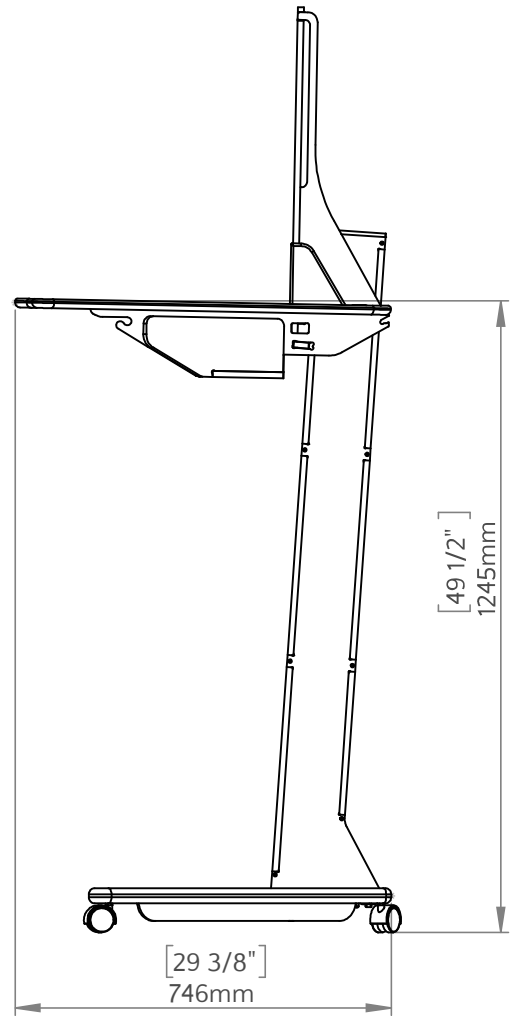
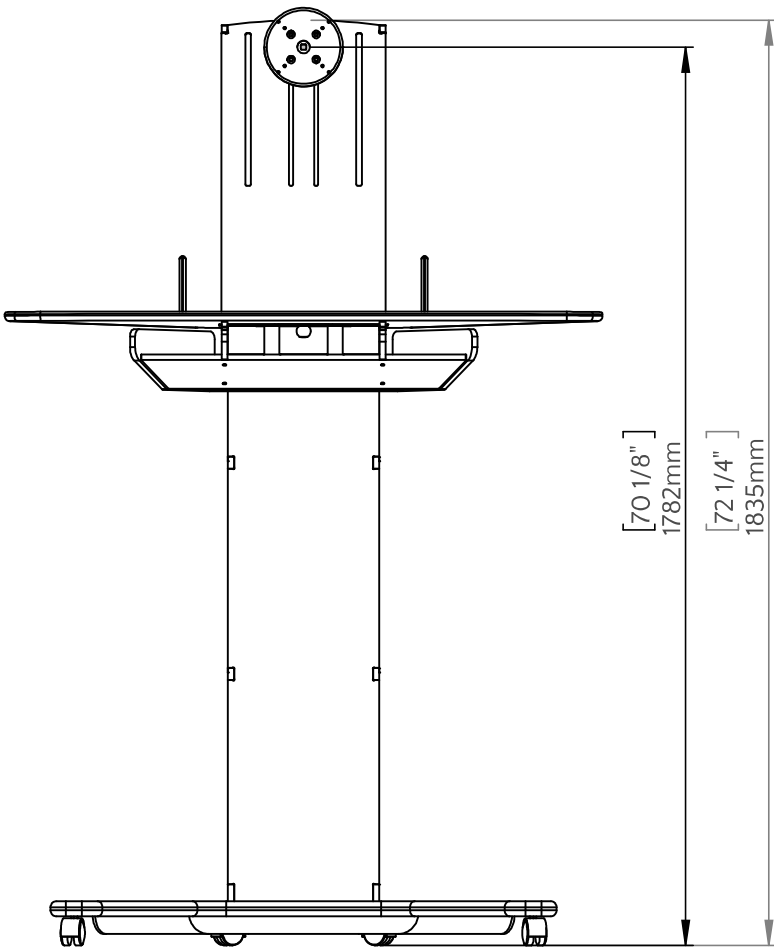

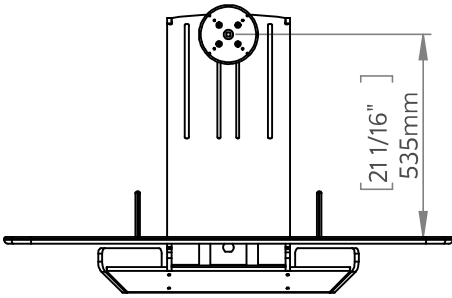

VESA - Maximum Standard Height, Single

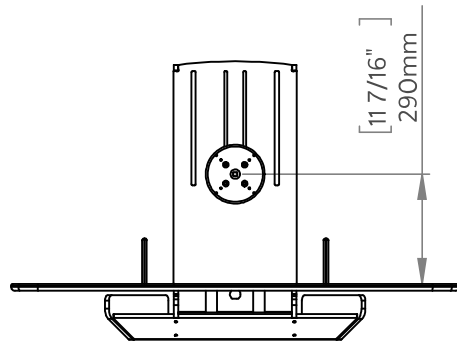

VESA - Minimum Standard Height, Single

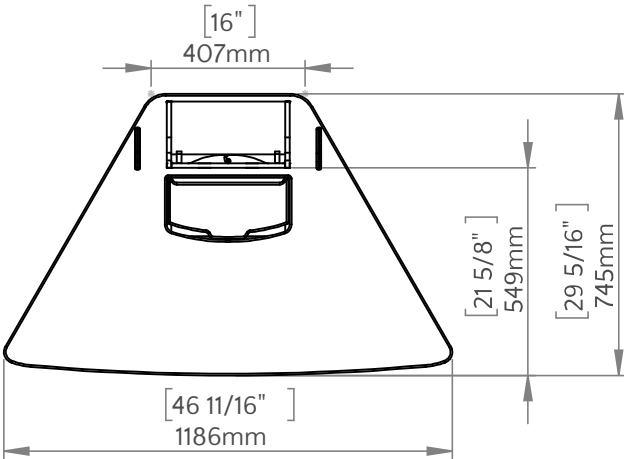

Platform Depth, Petal

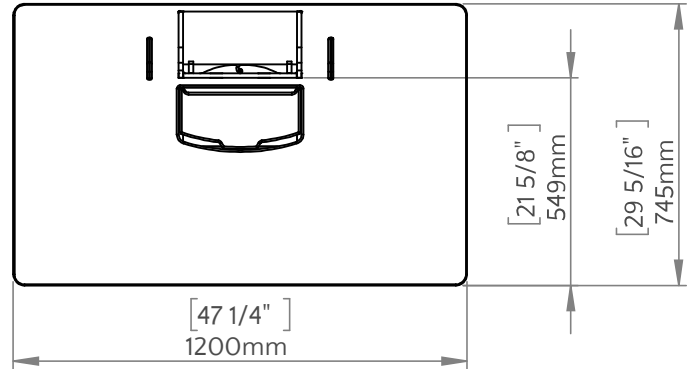

Platform Depth, Block

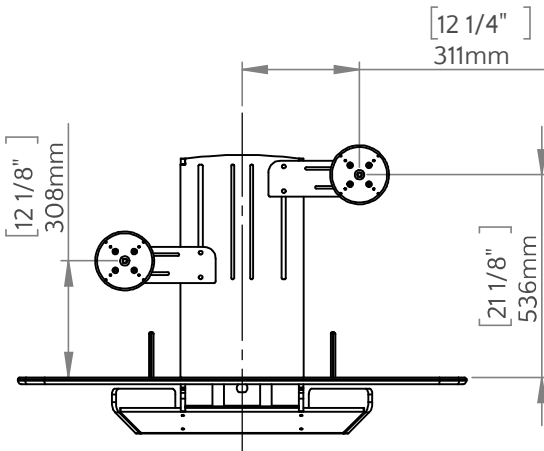

Max/Min Dual Screen Height and Offset

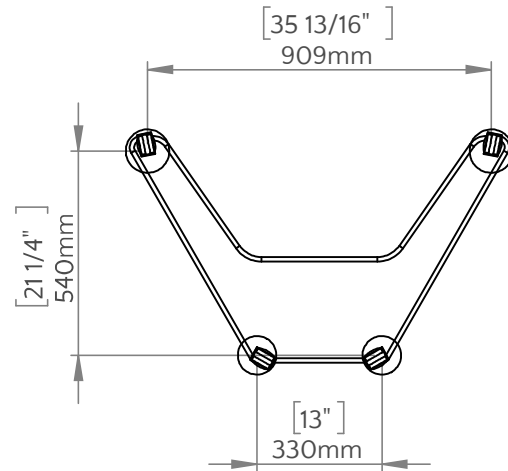

Wheel to Wheel Dimensions (centre)

Rated Weight Carrying Capacity		100kg*
Monitors	Mounting	VESA compatible mounting: 75x75mm 100x100mm
	Sizes	Various configurations including: Up to 1x 32", with smaller additional screen possible Up to 2x 27" using an extender arm (available separately) <i>We recommend installing no more than 8-10kg of monitors, as ease of movement and desk mobility may be impacted.</i>

* The Limber® Studio has been independently proof tested to withstand 150kg at the desktop platform, without failure. However loading at over 100kg is not warranted and may lead to degradation of your product.