

Firgelli Auto

TV Lift mechanism

www.FirgelliAuto.com

- Introduction
- Dimensions
- Installation
- Connections
- Operation

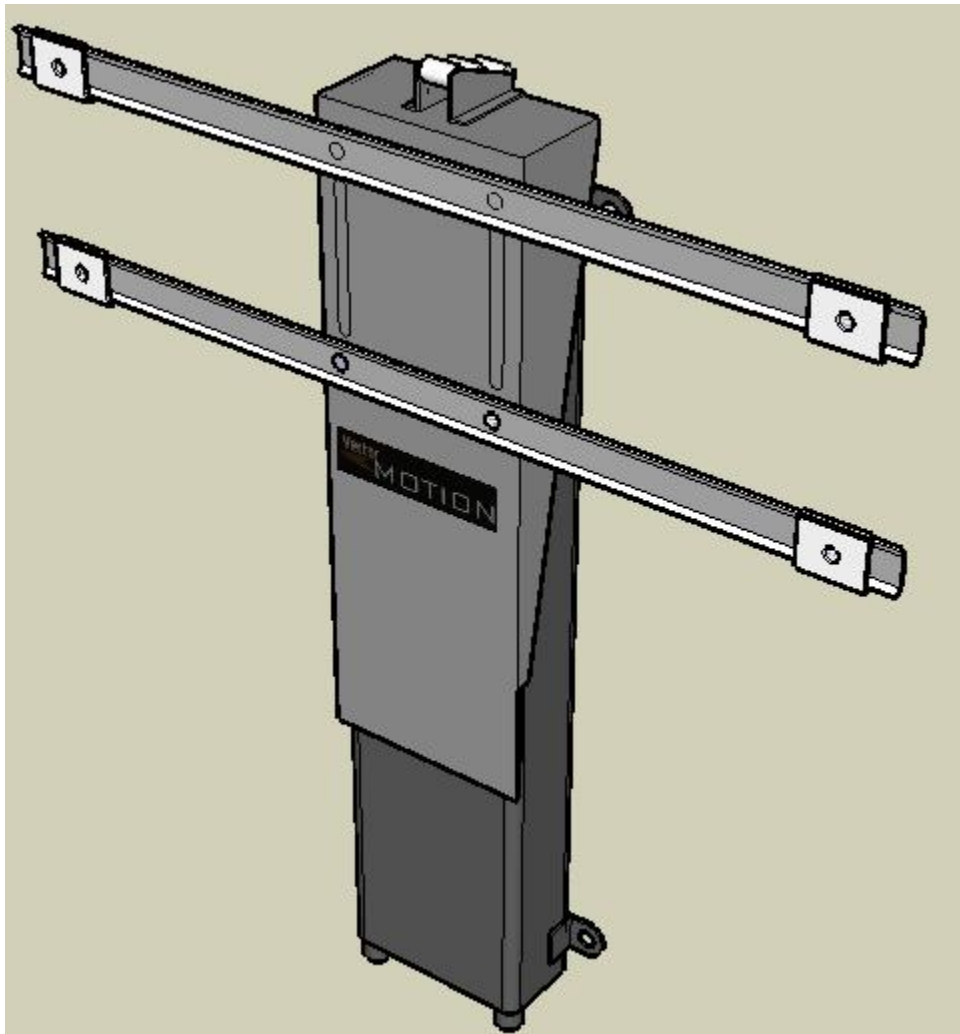

Introduction

- The TV Lift system is specifically designed for easy installation into cabinetry, AV rooms, meeting rooms, or any type of application where automatic lifting of equipment is required.
- The Lift Column, model FA-TVL-170-24-xx" is a telescoping type column made with prefabricated, inter-fitting solid steel tubes, and a 24VDC motor-gear box inside.
- There are three TV Lift system models to choose from, based on the size dimensions of your TV. All three models have the same maximum load capacity of 160 lbs (55 kg), which is sufficient to lift most 20-60 inch LCD & Plasma TVs on the market today. (Note: The PULL type application is not recommended for this TV Lift)
- The installation and set up of the system is extremely easy. Only four screws are required to attach the lifting column to the cabinet wall panel. The electrical connections between all the main parts like Lift Column, Control Box, Switch Box and IR receiver are plug types, which promote easy installation.
- Each TV Lift system is equipped with an IR (Infrared) remote control, and wired Switch Box. If the IR system fails, the Switch Box provides a backup to maintain the normal operation.
- The control box, with a built in microprocessor, provides the basic operational functions of Up/Down/Store/Recall. This self-protection feature continuously monitors the electrical current consumption of the motor, and will abort the operation immediately if an abnormal rise in the electrical current is detected.
- The control box is CE and UL approved that guarantees the compliance of all the necessary safety requirements.
- The accessories used to attach the LCD or Plasma TV to the lifting column are very simple and easily adaptable so that most LCD & Plasma TVs can be used with this TV Lift system.
- The height of the lifting column can be modified then “memorized” electronically after adjusting the mounting position of the TV using the different hole options on the TV bracket. This is done when the column lift is in the down position.

TV Lift Mechanism Dimensions

(Shown without TV bracket installed)

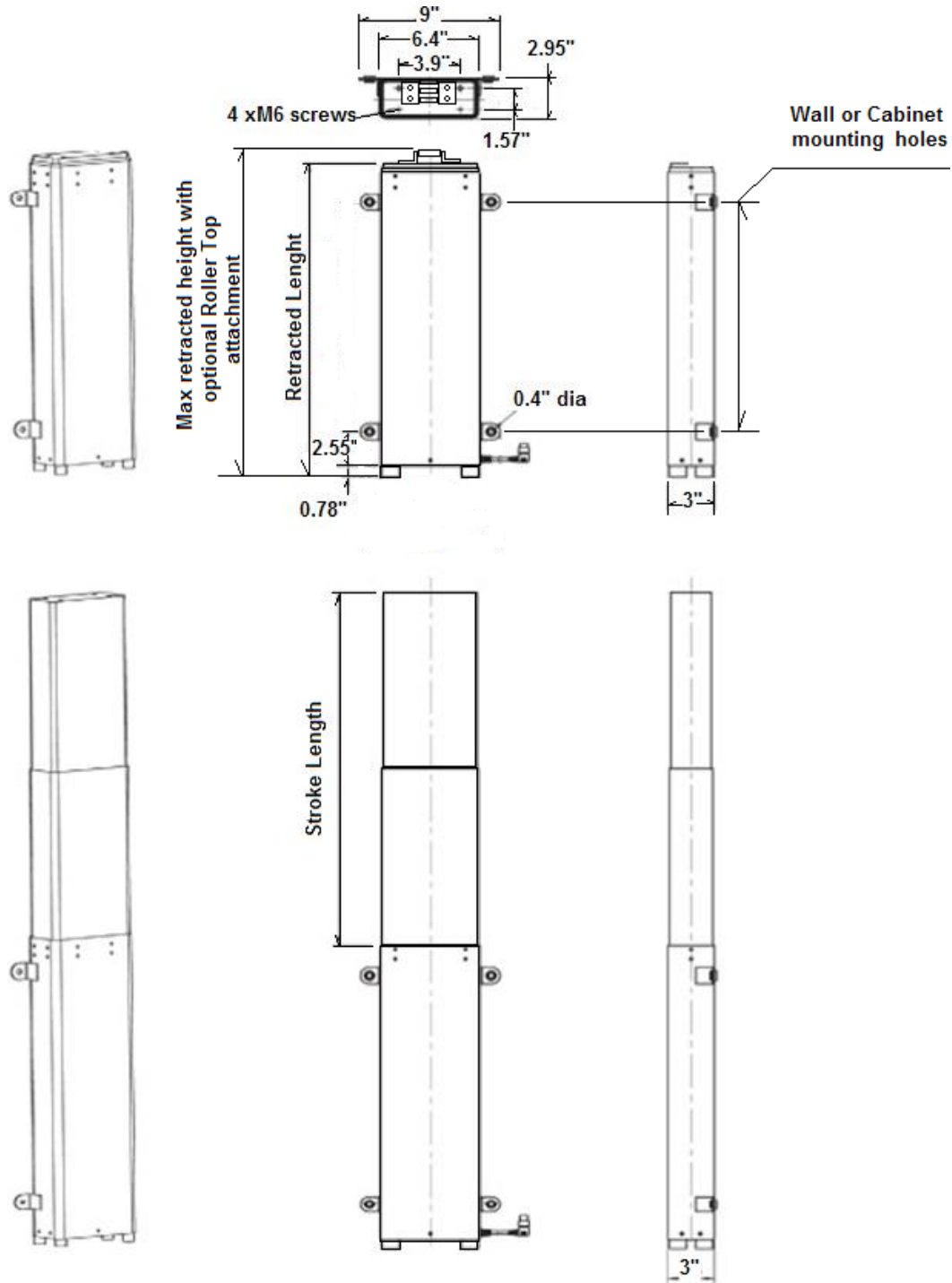

Model Number	Retracted Length (with Roller Top Installed)	Retracted Length w/o Roller Top	Stroke Length	Wall Mounting hole distance	Load	Speed full stroke
FA-TVL-170-24-36"	33.65"	32.08"	36"	25.6"	170lbs	25sec
FA-TVL-170-24-30"	29.35"	27.78"	30"	21.45"	170lbs	21 sec
FA-TVL-170-24-25"	25.75"	23.18"	25"	16.9"	170lbs	17 sec

Control Box:

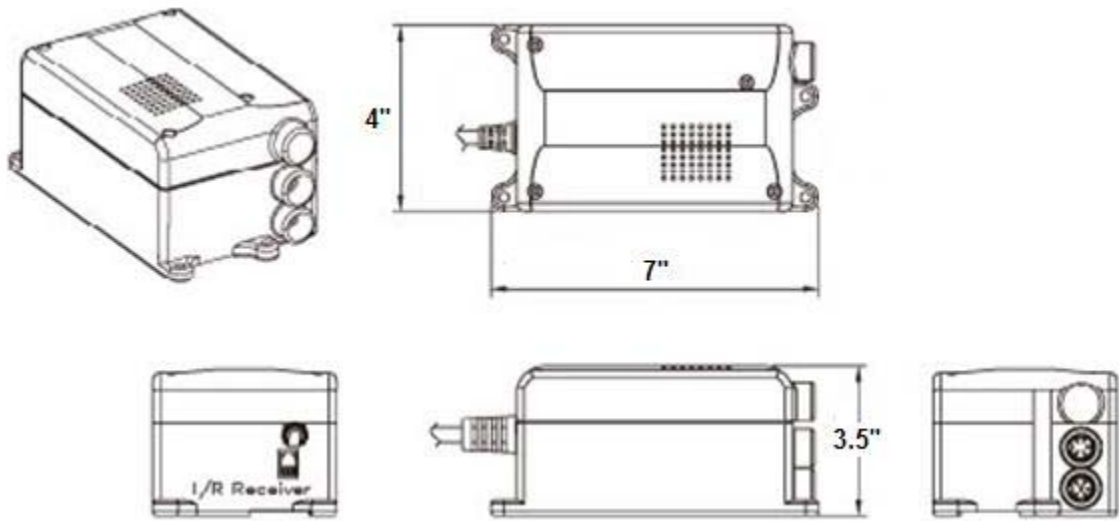

Hand Controller Box:

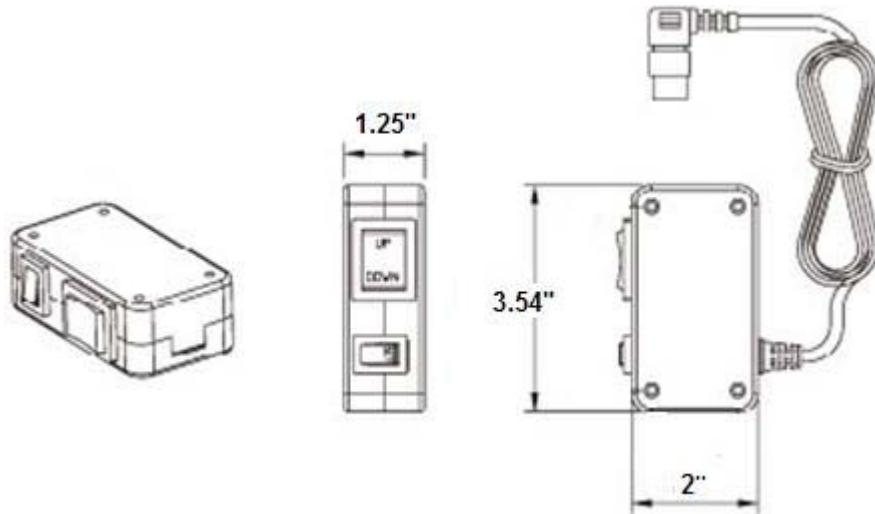

IR Receiver:

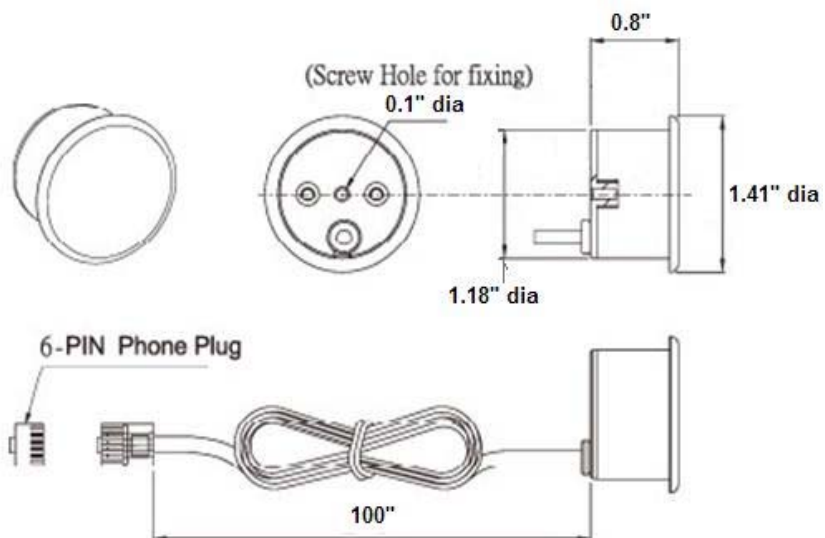

Universal TV Mounting Bracket:

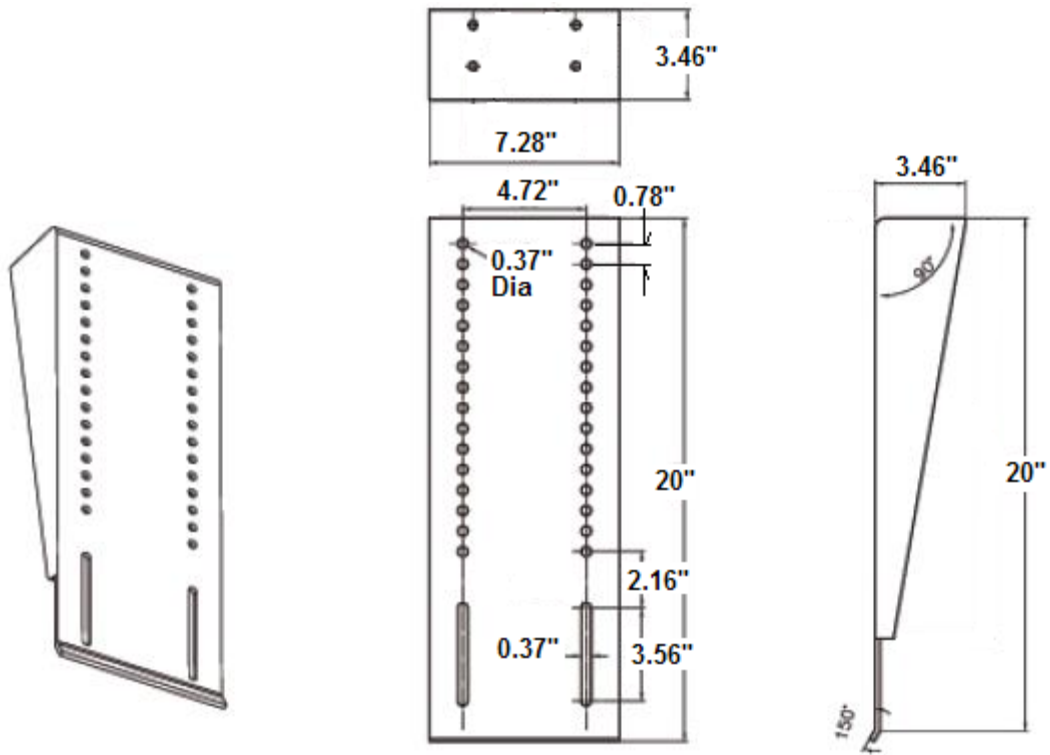



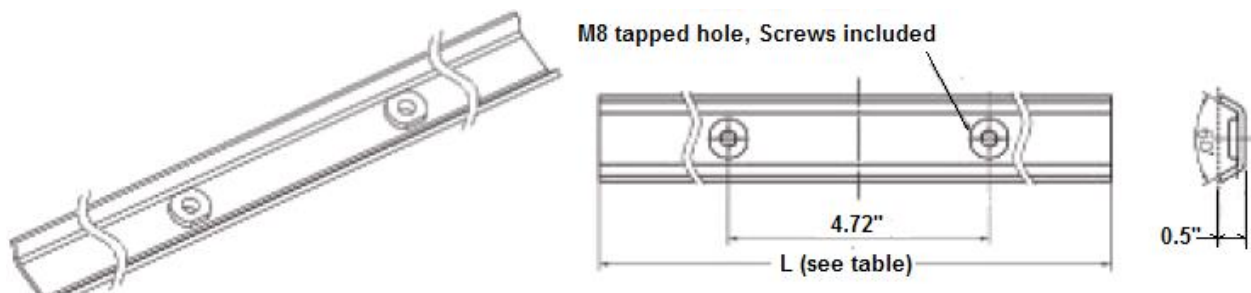







TV Mounting Bars:



MODEL #	L
FA -TVL-170-24-36"	30"
FA -TVL-170-24-30"	26"
FA -TVL-170-24-25"	21.6"

Parts List:

No.	Drawing	Description	Q'ty
1		Wheel for rolling lid on cabinets	2
2		Wheel shaft	2
3		Wheel shaft holder Right side	1
4		Wheel shaft holder left side	1
5		Screw M5	4
6		Manual screw M5	1
7		Washer	12
8		Slider to attach to back of your TV	4
9		M8 Screws	12
10		Wrench	1

TV Bracket Installation Instructions:

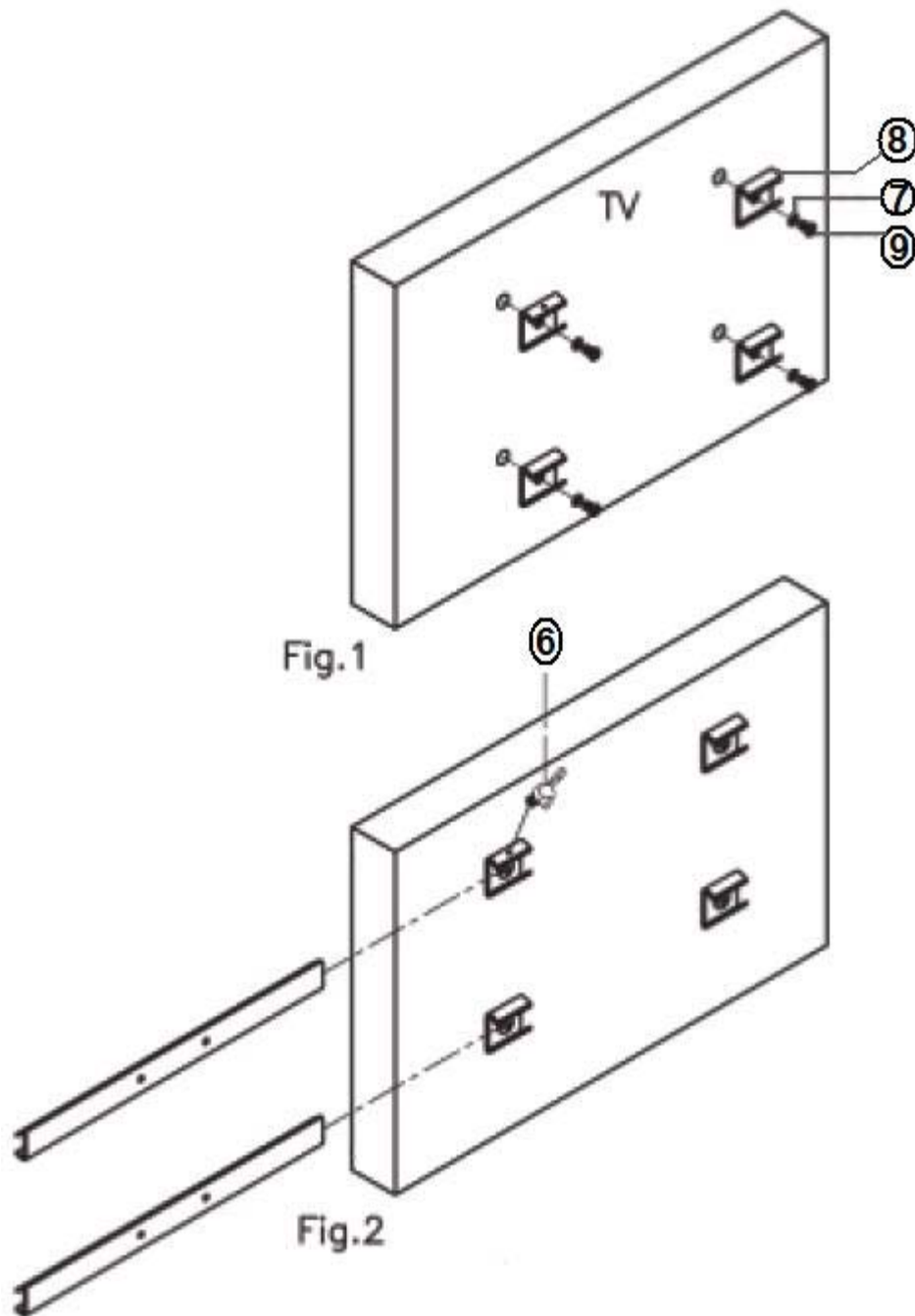

Note: Most TV's come with their own Mounting screws already screwed into the back of the TV, or loose in the TV Box. Use those screws instead where possible to ensure you use the correct screw size. The screws used in this Kit are M8 screws that may or may not fit your TV. In addition you may need to open up the screw hole in part 8 using a drill to make the hole larger if your TV's screws are larger than M8

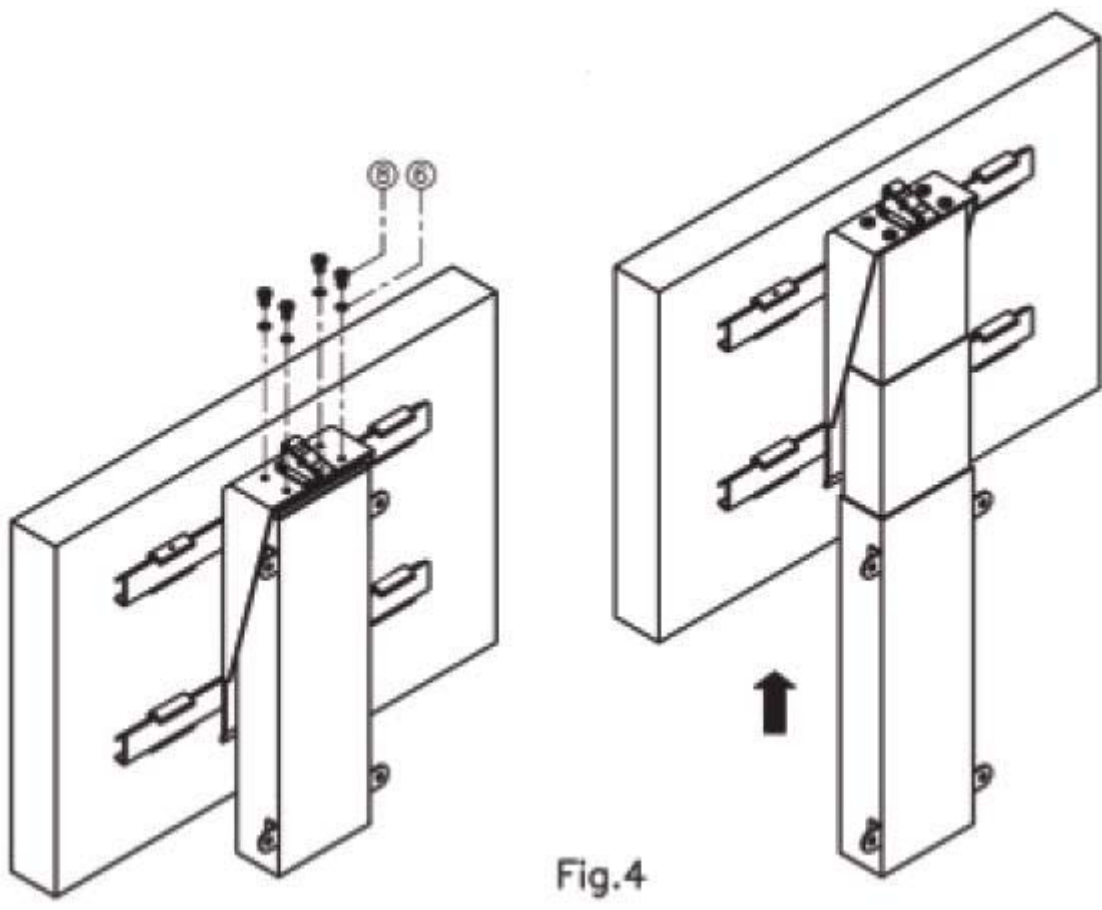
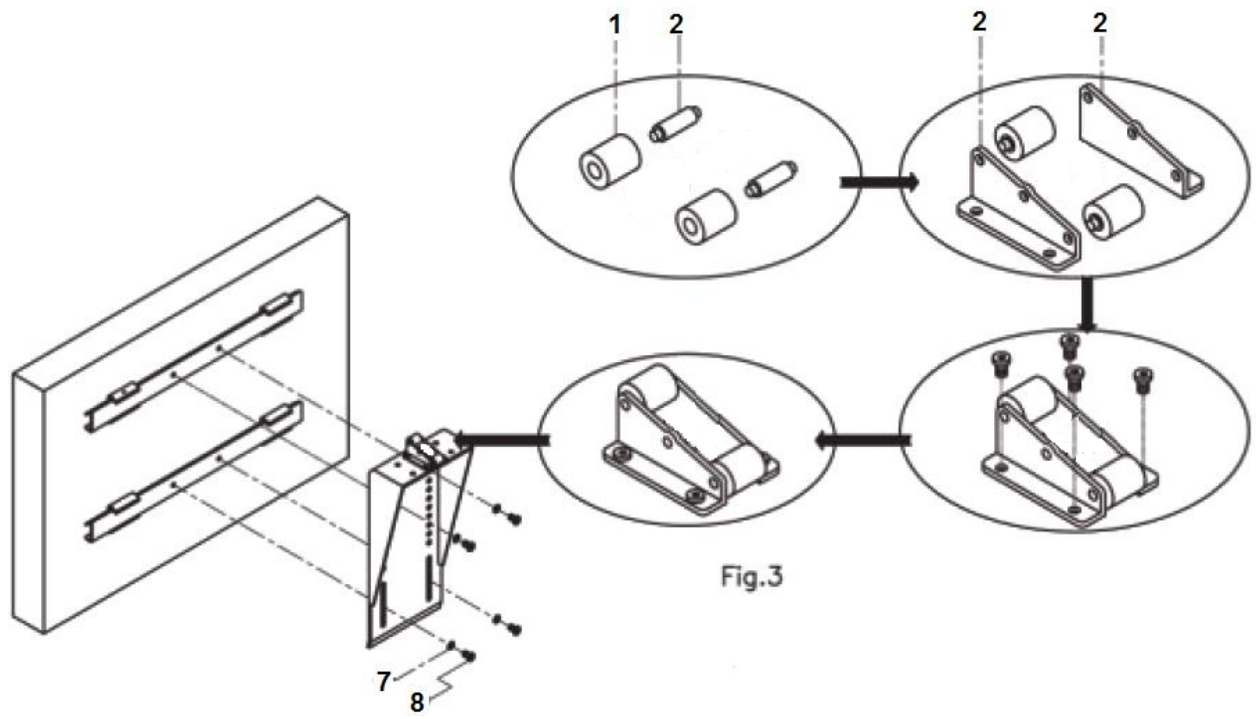

Connecting the TV Lift

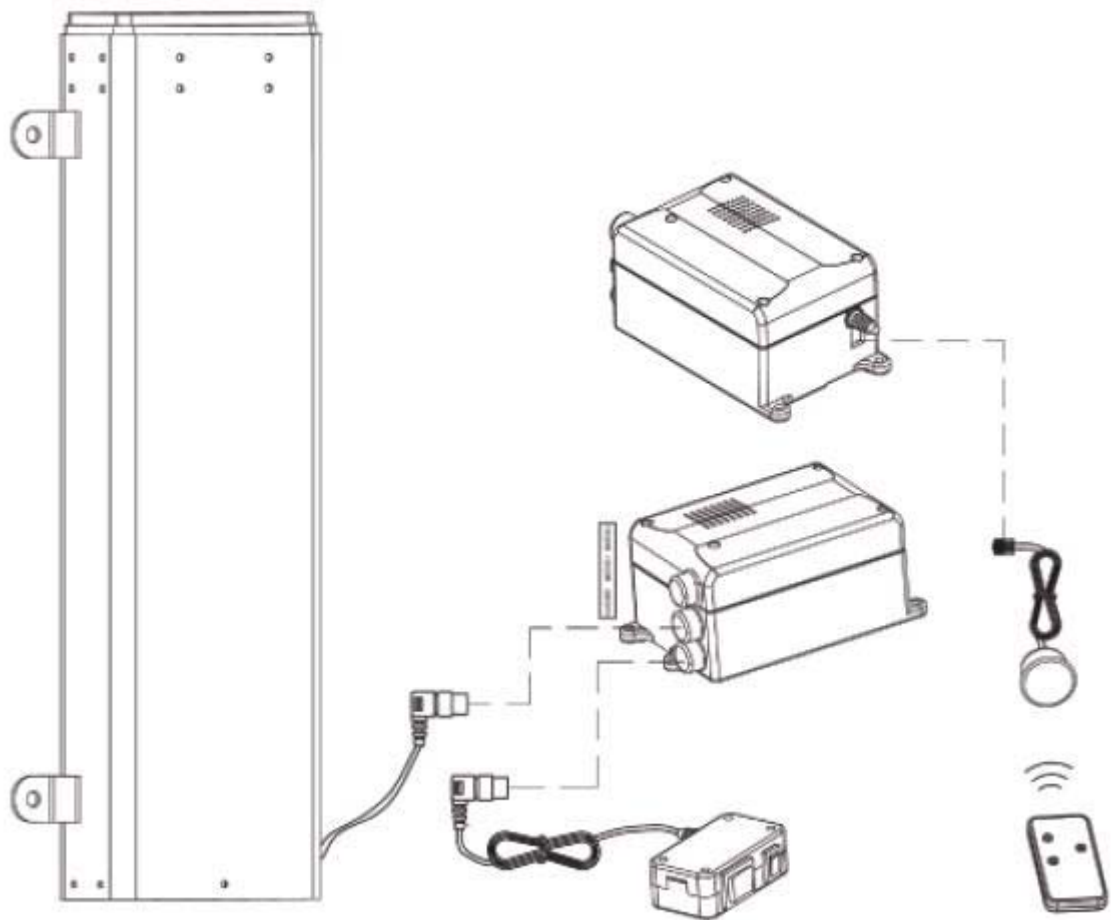

Caution:

- 1. Do not plug the mains in before all the parts are connected**
- 2. This is designed for North American 110vac usage only**
- 3. Do not open the control box, otherwise an electrical hazard may occur**
- 4. Before operating be sure that there are no objects in the path of the TV lift, both above the TV and below or damage to your TV and or the TV Lift will occur**
- 5. For safety reasons, before operation be sure there are no children or pets close to the TV lift.**

To operate the TV lift once the upper limit has been set you simply press the M button on the remote and the TV will lift to the upper pre-set position. To make the TV retract simply press the down button and it will retract and automatically stop when it gets to the bottom. You do not need to hold the button down for normal movement once the limits are set, just press the button once.

Operation by IR Remote Control

1. When operating, the IR remote control must be pointed to the IR receiver, and the distance between IR receiver and remote control should be within 15 feet.
2. Press "UP" button, the Lifting column will go upward continuously.
3. Press "DOWN" button, the Lifting column will go downward continuously.
4. When lifting column is moving, pressing any button will stop the movement.

To set the upper Limit:

1. Move the TV up to the position you want it to stop at, then press the "M" button for 5 seconds, until the LED of the IR Receiver flashes 3 times, the height of the lifting column is then memorized.
2. Press "M" button a second time then release in one second, the lifting column will move automatically to the memorized height.
3. After the memory has been set use the "M" button to lift the TV to the memory position

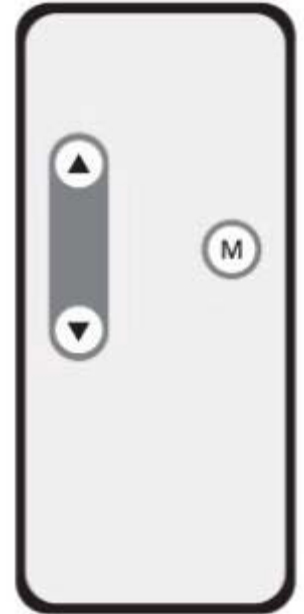

Operate by Hand Control

1. Before operating, be sure the "SET" switch stays at normal side, not "SET" side.
2. Press "UP" switch, the Lifting column will go upward continuously.
3. Press "DOWN" switch, the Lifting column will go downward continuously.
4. When lifting column is moving, pressing any switch will stop the movement.
5. Move the TV up to the position you want it to stop then press the "SET" button for 5 seconds, until the LED of the IR Receiver flashes 3 times then switch back to the normal side, the current stop of the lift is now memorized.
6. Press "SET" switch then switch back in one second, the lifting column will move automatically to the memorized height.

