

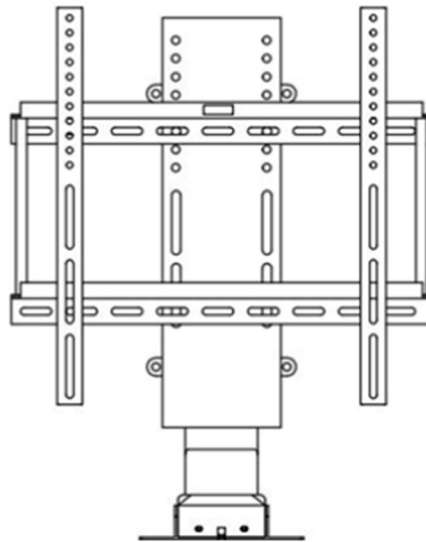

TV LIFT KIT ASSEMBLY INSTRUCTIONS

MODELS: FA-TVL-180-25 / FA-TVL-180-30 / FA-TVL-180-36 / FA-TVL-180-40

The FA-TVL-180 Series Pop-Up TV Lift



Please take time to identify all the parts and hardware prior to assembly. Lay out all the components on a padded /carpeted area to avoid damage.

TOOLS REQUIRED

Allen Wrenches
M6 M8



Phillips head screw



HARDWARE



2 Screws M5x50
M5x50



4 Screws
M6x16



8 Hex Bolts
M6x14



4 Hex Bolts
M8x16



4 Nuts
M8



8 Spring Washers
M6



8 Washers
M6

COMPONENTS



Column



Mounting
Bracket

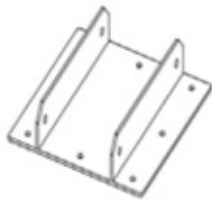

Mounting
Base

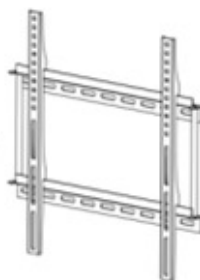

TV Mounting
Bracket

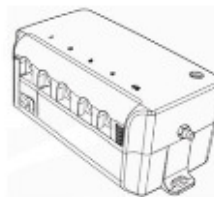

Control Box



Hand
Controller



Remote
Controller



Connection &
Power Cables

TV LIFT KIT ASSEMBLY INSTRUCTIONS

MODELS: FA-TVL-180-25 / FA-TVL-180-30 / FA-TVL-180-36 / FA-TVL-180-40

NO.	TYPE	QTY
1	Mounting Base	1
2	Column	1
3	Washers M6	8
4	Spring Washers M6	8
5	Hex Bolts M6x14	8
6	Screws M5x50	2
7	TV Mounting Bracket	1
8	Nuts M8	4
9	Mounting Bracket	1
10	Screws M6x16	4
11	Hex Bolts M8x16	4
12	Connection and Power Cable	1
13	Remote	1
14	Handset	1
15	Control Box	1

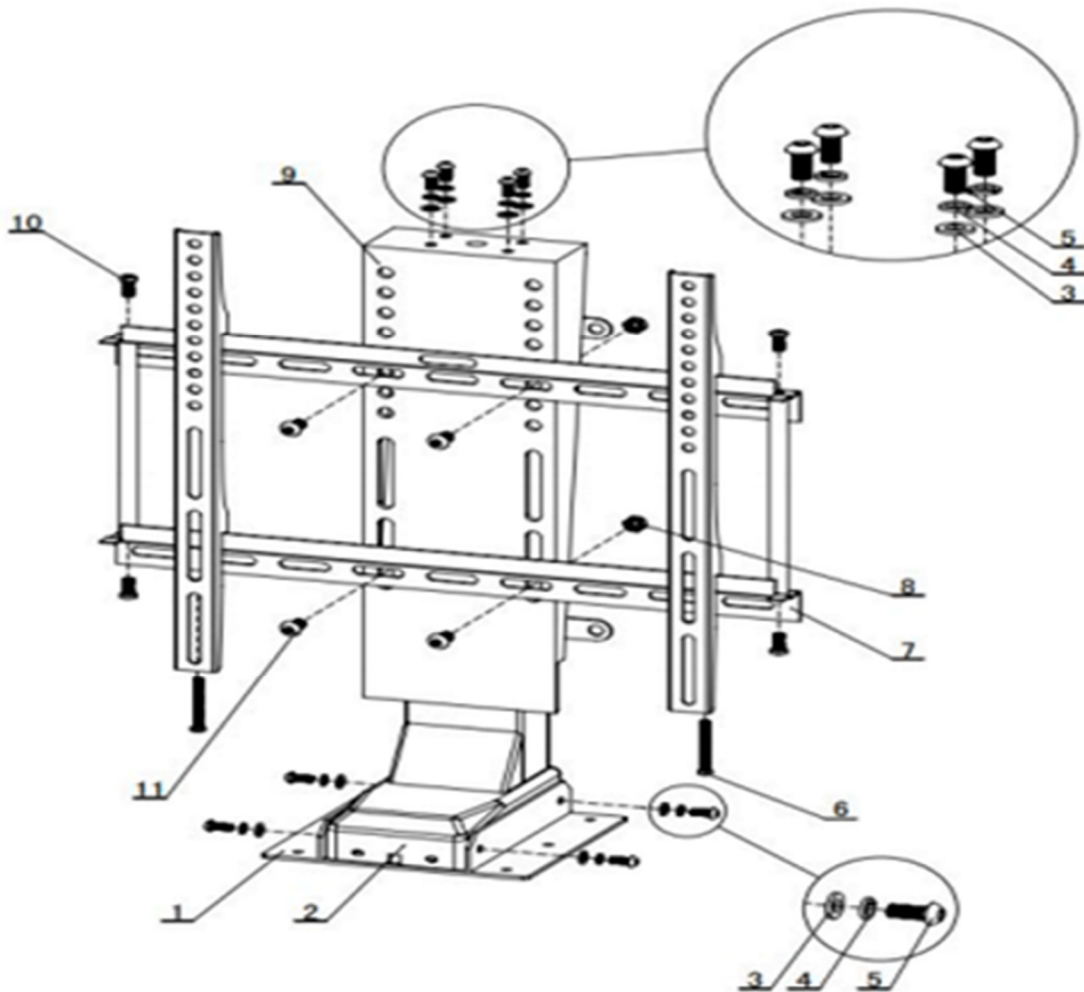

ASSEMBLY AND INSTALLATION

When installing the TV Lift, you have two mounting options. You can use the base plate and mount it to the bottom of a cabinet or floor. The second option is to use the 4 back mounting tabs to mount it against a wall or the back of a cabinet.

1. First mount the base plate to the floor or ceiling if used upside down. Then use **4 Hex Bolts M6x14**, each with a Spring Washer and Washer, to attach the **Mounting Base** to the bottom of the **Column**. Tighten the 4 Bolts (2 per side).

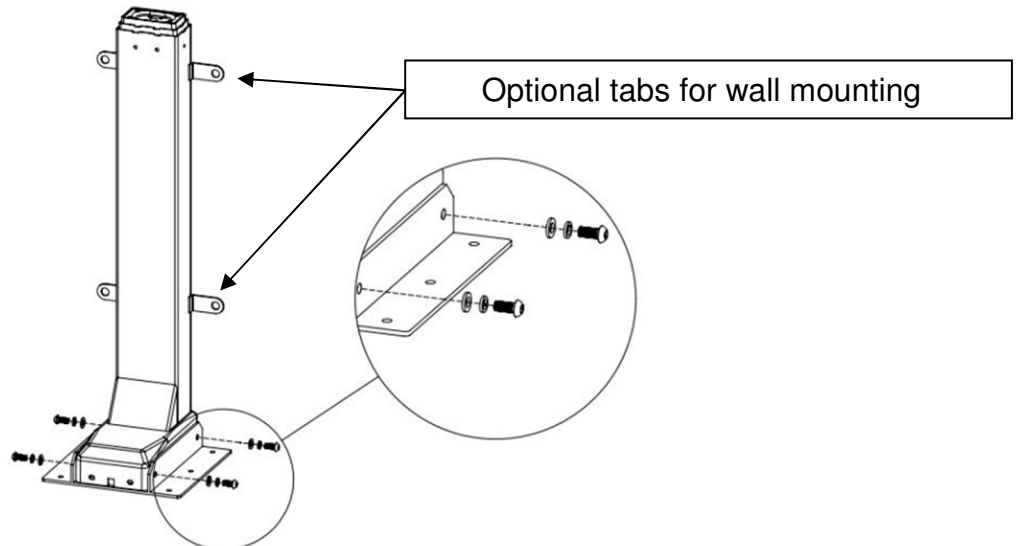

2. Use **4 Hex Bolts M6x14**, each with a Spring Washer and Washer, to attach the **Mounting Bracket** to the top of the **Column**. Tighten the 4 Bolts.

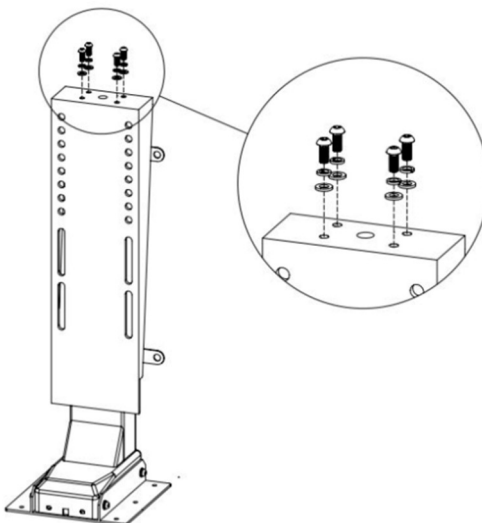

3. Use **4 Screws M6x16**, to assemble the **TV Mounting Bracket** as follows.

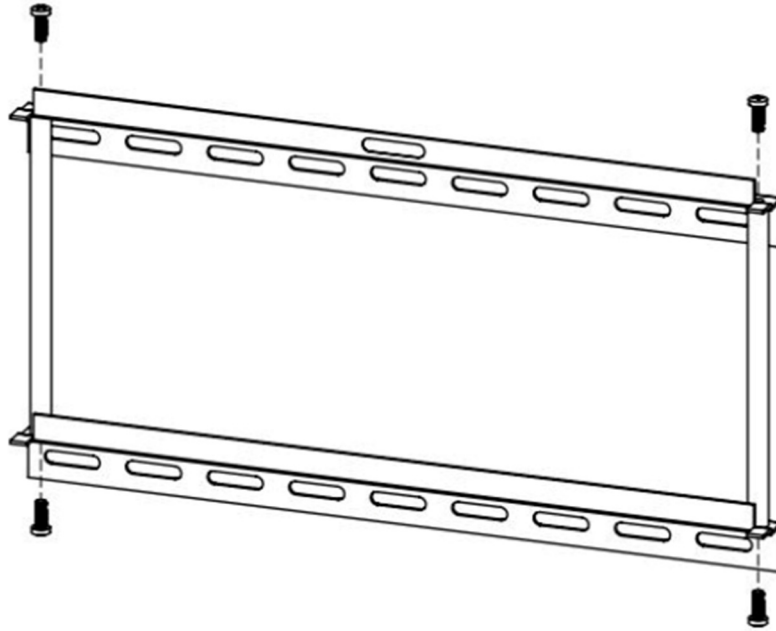

The long arms will attach to the back of your flat screen TV. All TV's come with the same mounting holes, this bracket is designed to be universal so that it works with all TV's and gives you flexibility to position the TV relative to the Lift however you prefer.

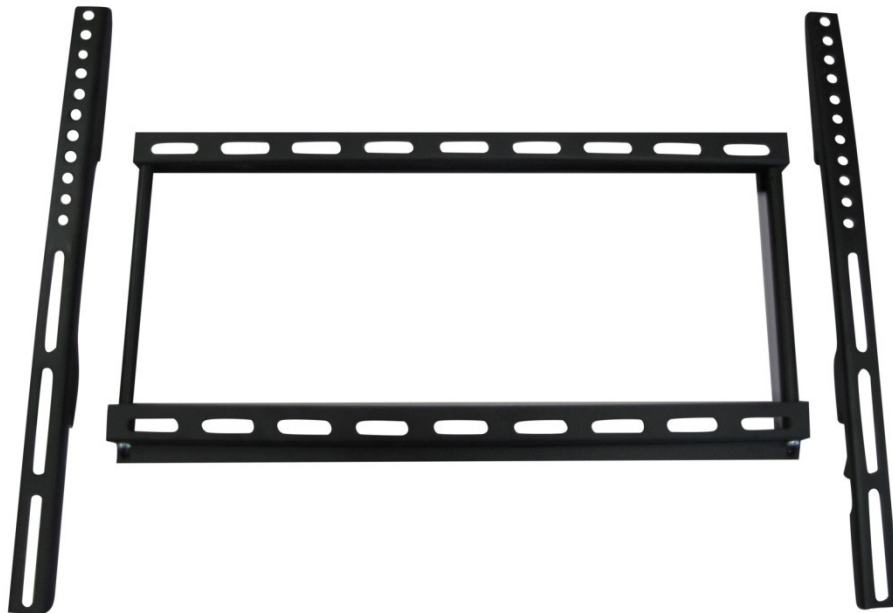

4. Use **4 Hex Bolts M8x16**, with **4 Nuts M8**, to attach the **TV Mounting Bracket** to the **Mounting Bracket**. Tighten the 4 Bolts. The Mounting Bracket comes with different mounting positions to allow for different sized TV's.

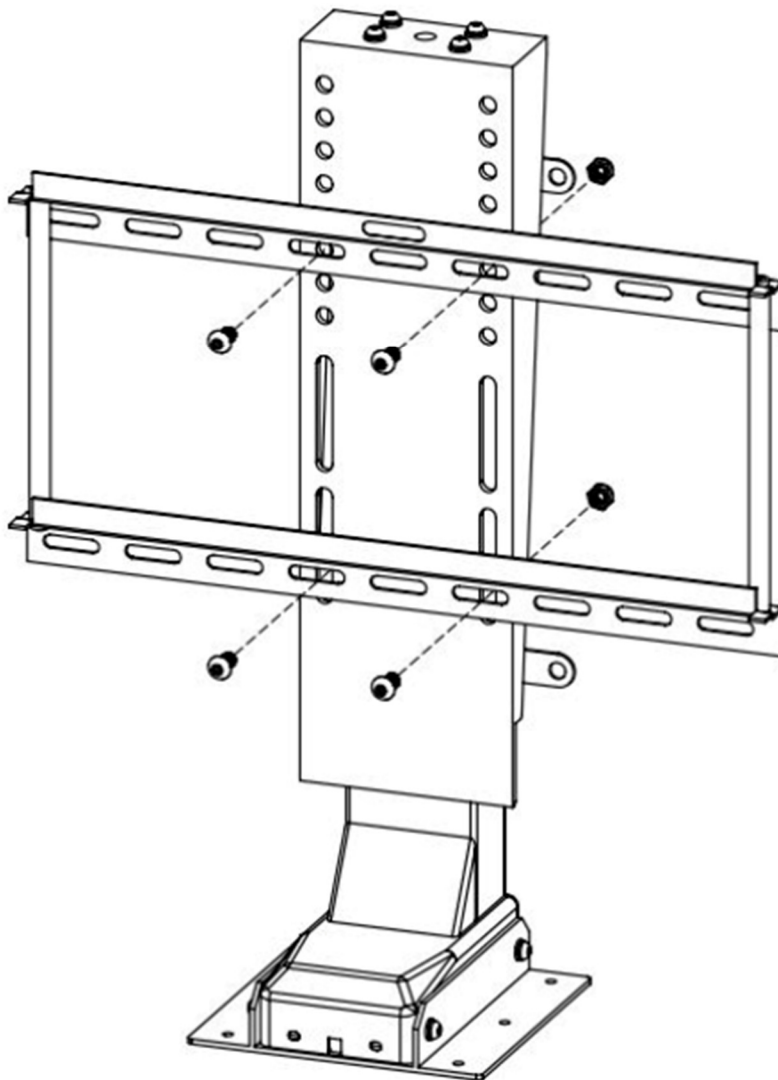

- Secure the other 2 long arms of the TV Mounting Bracket onto the back of the TV set with 4 screws included with the TV set. Then hang the TV set onto the **TV Mounting Bracket** as shown. Use **2 M5x50 screws** to tighten on the bottom.

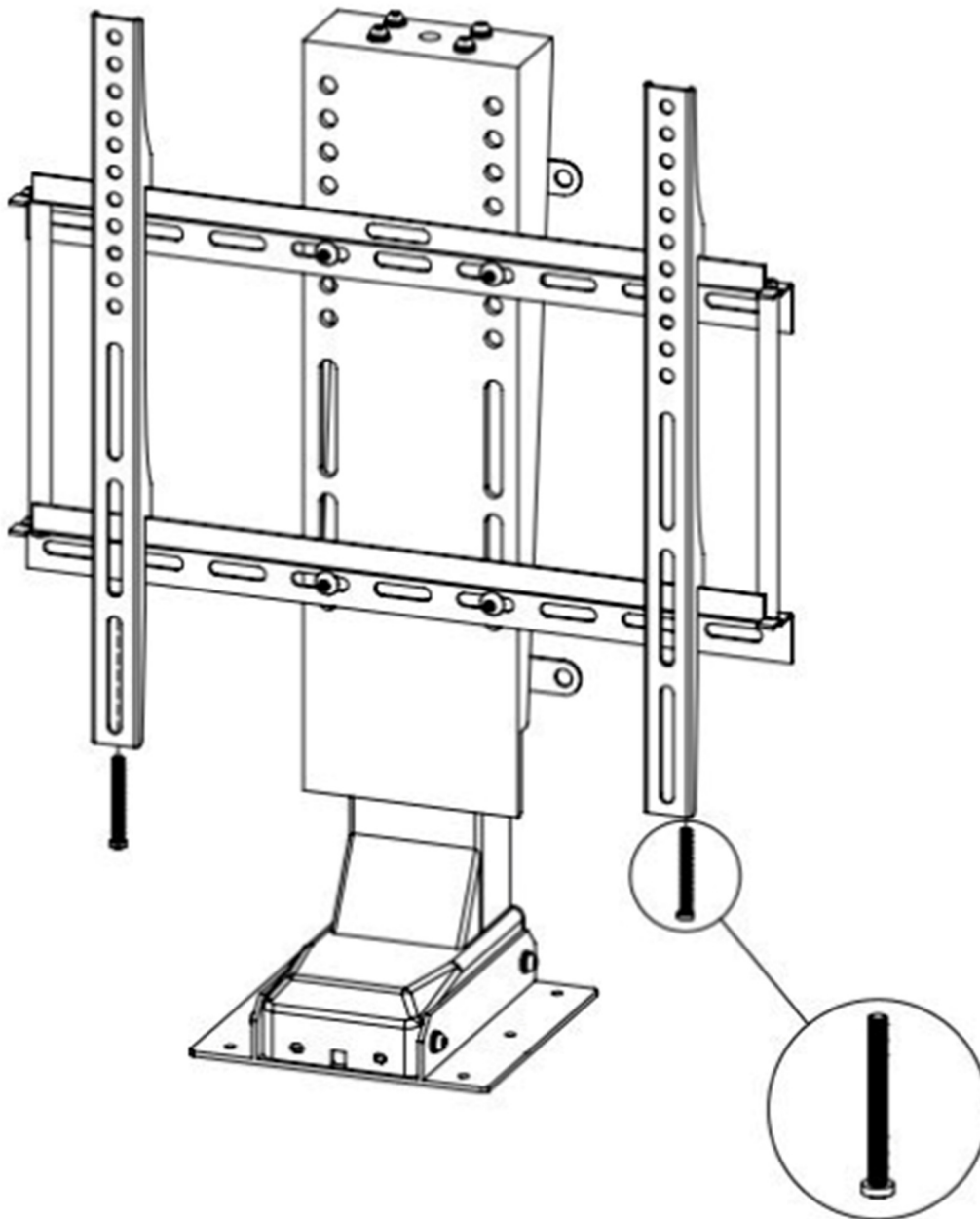

TV LIFT KIT ASSEMBLY INSTRUCTIONS

MODELS: FA-TVL-180-25 / FA-TVL-180-30 / FA-TVL-180-36 / FA-TVL-180-40

6. Connect the hand controller (9 pin plug) with the HS port on the control box. Connect the lift column (5 pin plug) with the 1st port on control box. Ports No.2-4 are blocked and cannot be used. Connect the power cable to the control box and plug into power source.

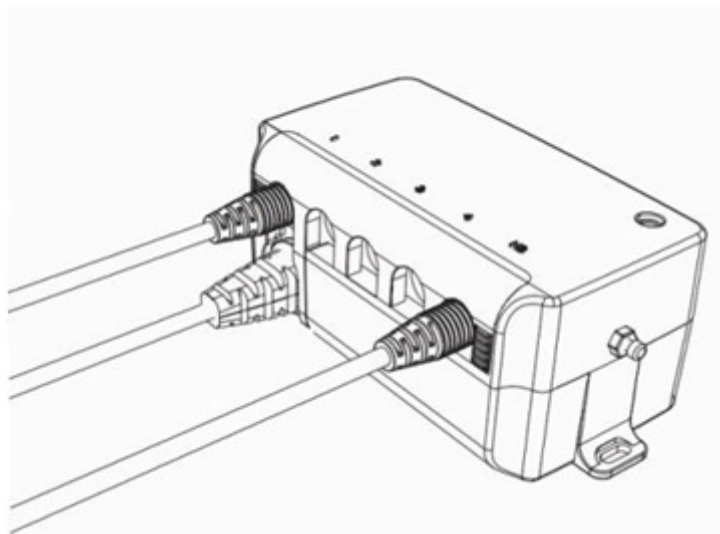
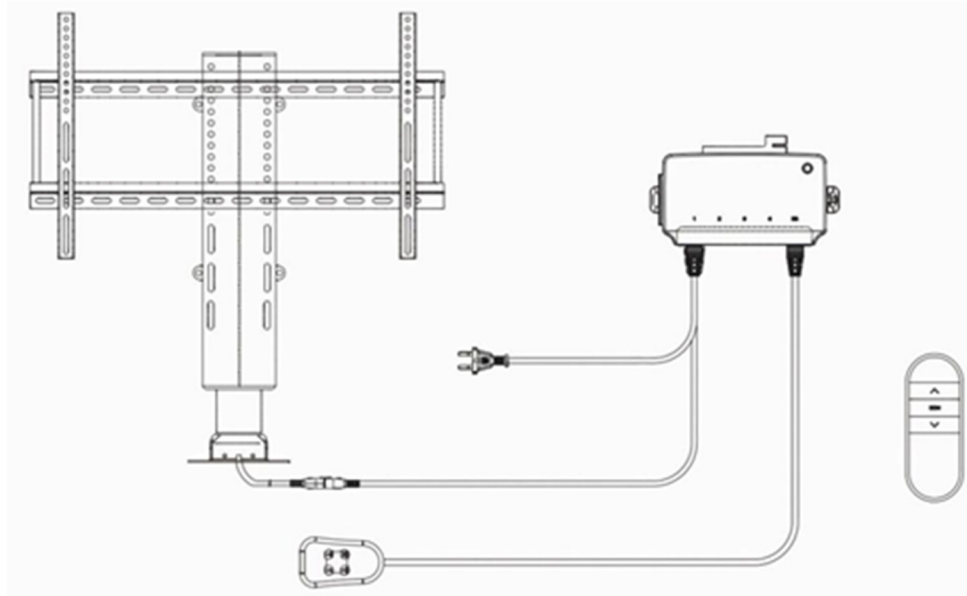

OPERATION

RESET:

The system has to perform a complete RESET in order to operate. The red signal light will flash at 0.5 second intervals indicating a RESET is required.

Press and hold the RESET button on the **Hand Controller** to lower lift all the way to the bottom. Once the lift reaches the bottom it will then raise 7mm and the light shuts off indicating the RESET is complete.

The RESET button must be held and cannot be released during the process. The LED light on the Hand Controller will flash rapidly, when light turns off, it means the RESET is done.

Notes:

- ❶ Before RESET procedure is completed; no buttons will function except the RESET button on the hand controller.
- ❷ Press and hold RESET button 5 seconds in order to activate the RESET procedure intentionally.
- ❸ When the lift is moving, pressing RESET will stop its motion. If RESET is held for at least 5 seconds, the system will enter the RESET procedure automatically.

STUDY:

Before using the **Remote Controller**, it is necessary to pair the remote to the receiver:

Press $\wedge + \vee$ on the **Remote Controller** as well as the STUDY button on the **Hand Controller** simultaneously and hold. The LED light will flash three times, which indicates studying is complete. Release buttons when studying process is complete.

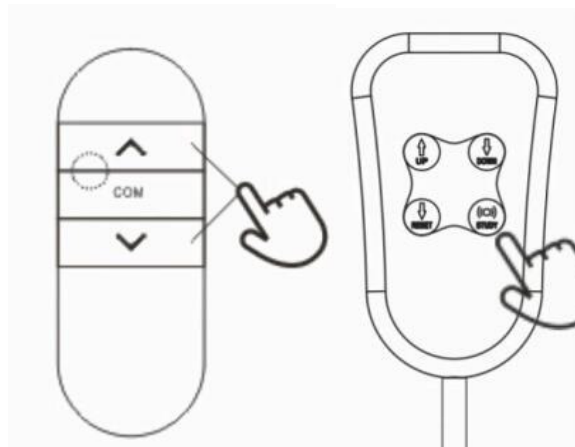

After completing the RESET and STUDY processes, the following functions are achievable:

REMOTE CONTROLLER:

Press \wedge :

Sustaining Mode: press button once and the lift will extend continuously up; press any button to stop it or it will stop automatically at the set upper limit spot.

Momentary Mode: press and hold button to raise the lift, release button and the lift stops moving.

Press ∇ :

Sustaining Mode: press button once and the lift will retract continuously down; press any button to stop it or it will automatically stop at the set lower limit spot.

Momentary Mode: press and hold button to lower lift, release button to stop;

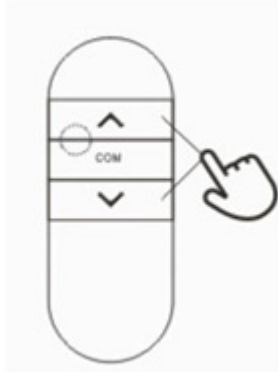

COM Button:

Use the COM button to switch between sustaining and momentary modes.

Hold COM button 10 seconds to switch from momentary to sustaining mode and vice versa. When the switch is conducted successfully, the red light will be on and the remote controller will flash to signal that the change has been saved.

- The setting will be remembered for future remote use.

HAND CONTROLLER:

UP button: Press button once, lift rises all the way up to the upper limit position. Press button again to stop movement before limit has been reached.

Down button: Press button once, lift will lower go all the way down to lower limit position. Press button again to stop movement before lower limit has been reached.



To set the **upper-limit position**: Hold the UP and RESET buttons for 3s, when the column reaches the spot, you want to set as the upper limit position release the buttons.

To set the **lower-limit position**: Hold the DOWN and RESET buttons for 3s, when the column reaches the spot, you want to set as the lower limit position release the buttons.

- The system will remember the upper and lower limit positions you have set for future use.

OTHER INFORMATION

- If the column is operated continuously for 3 minutes, it will enter a *working protection mode*. All buttons will be disabled during the process. It will return to normal operation after 16 minutes. When the system enters into *working protection mode* the indicator light will flash once every 3 seconds.
- If the lift stops working for any other reason, perform RESET procedure



TV LIFT KIT ASSEMBLY INSTRUCTIONS

MODELS: FA-TVL-180-25 / FA-TVL-180-30 / FA-TVL-180-36 / FA-TVL-180-40

Specifications:

Model	FA-TVL-180-25	FA-TVL-180-30	FA-TVL-180-36	FA-TVL-180-40
Stroke	25.5"	29"	35"	39"
Retracted Length	22.4"	25.5"	29.6"	31.89"
Extended Length	48"	54.5"	64.6"	70.89"
TV Sizes	25" – 60"			
Input Voltage	110 VAC			
Force	135 lbs.			
Lifting Speed	0.87"/second (with load)			
Duty Cycle	10%, max 2 min. continuous use			
Operating Temperature	+5° C - +40° C			
Overload Protection	Built-In			
Material	Powder Coated Steel			
Additional Feature	Adjustable Height			

Thank you for purchasing our TV Lift.