



FA-SYNC-2 Synchronous Control Board User Manual

The Firgelli Automation FA-SYNC-2 Synchronous Control Board allows you to move two actuators in step with the same speed irrespective of load. Unsynchronized actuators can lead to bending loads which is likely to be disastrous for both the load and the actuator. Common applications include, but are not limited to: wine cellar trapdoors, RV roof lifts, tonneau covers, and table lifts.

This board only works with a select few actuators with inbuilt feedback sensors. Actuators must be of the same type, stroke length, and force. Using different actuators will not work.

Compatible actuators: Bullet 36 Cal, Bullet 50 Cal, Optical Series 200lb, and Optical Series 400lb

Not compatible: Bullet Mini, Bullet 23 Cal, Optical Series 35lb, and all other types of actuator



NOTE: This diagram shows a toggle switch and a remote control board. This is only to show that both connections are possible, **connect only one, not both**

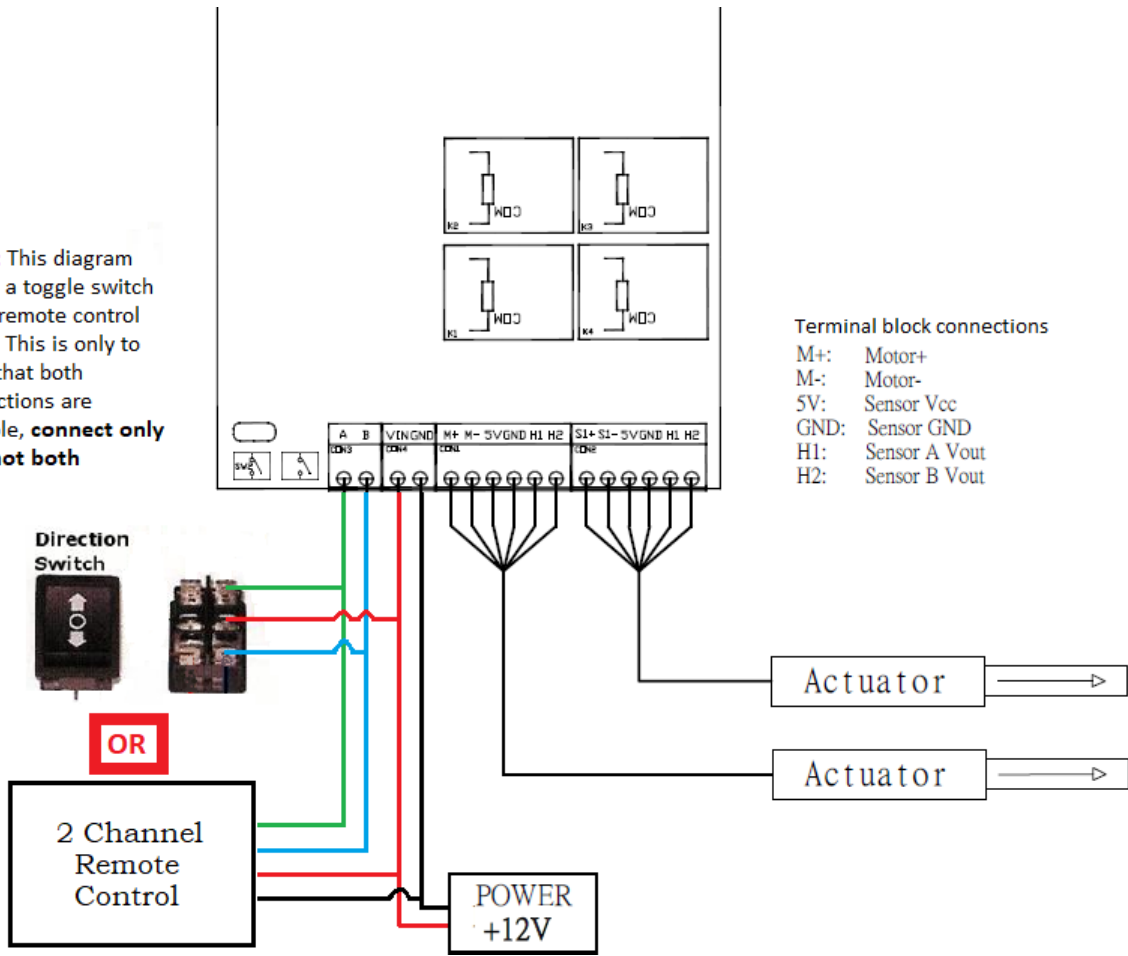

Connecting the FA-SYNC-2:

The leftmost, two-pin, green terminal block plug (labeled A & B) is for user input. Connect either a toggle switch or Firgelli's *2 Channel Remote Control Board*. **NOTE:** the diagram shows both a toggle switch and a remote control board, this is only to show that both connections are possible, **connect only one, not both**.

The next two-pin, green terminal block plug (labeled VIN & GND) is for a 12V/24V power input. This control board requires at least a 12V at 10 amps. **WARNING:** do not reverse the polarity of the input voltage; the unit will be damaged permanently if polarity is reversed.

The remaining six-pin, green terminal block plugs are for your actuators. Connect wires from each actuator to their respective terminal blocks as per the table on the following page.

WARNING: Wire color is subject to change. Confirm color by inspecting sticker on actuator.

FA-SYNC-2 Board	Bullet 36 & Bullet 50 Cal	Optical Series 200lb and 400lb
M+	M+ (Red wire)	M+ (Red wire)
M-	M- (Black wire)	M- (Black wire)
5V	VCC +5V (Yellow wire)	+5V (Blue wire)
GND	GND (White wire)	GND (Yellow wire)
H1	Data 1 (Brown wire)	Output (Green wire)
H2	Data 2 (Green wire)	Not connected

Calibrating the FA-SYNC-2:

Once all wires are connected the board must be calibrated to the specific type of actuator you are using. To do this, the control board will count the number of signal pulses from the encoder inside the actuator during a complete actuation cycle. Follow the procedure:

- Ensure actuators are laying on a table and not connected to your load or application
- Confirm wiring connections
- Press and quickly release the right-most momentary switch labelled "HOME". You will hear the relays on the circuit board click once and the actuators will all begin retracting (if they start extending instead of retracting simply reverse the order of the M+ and M- connections)
- When all actuators are fully retracted the relays will click several times. Once they stop, press and hold the "HOME" button until the actuators begin extending.
- The actuators will fully extend, pause, and then fully retract. Once retracted you will again hear the relays click several times.
- The FA-SYNC-2 board is now calibrated and your actuators can be installed in your application. The control board will remember the calibration settings even if power is disconnected during installation.



| HOME Button
Memory Height Button

Operating the FA-SYNC-2:

Using either the toggle switch or Firgelli's *2 Channel Remote Control Board* you can move the actuators in and out. Even if the load is unevenly distributed across the actuators, they will all move in synchronous.

The FA-SYNC-2 has the ability to store one "memory" location. To set this memory location, move the actuators to your desired position, then remove the black plastic slide at the top of the control board. Press and hold the left-most momentary button, after several seconds you will hear the relays click: you can now release the button. Move the actuators to a different position. When the same momentary button is pressed and released quickly, the actuators will automatically move to your preset memory location. To override this position with a new one simply repeat the same steps.

LED Display Status:

- Green light: standby mode
- Flashing green light: actuators in motion
- Flashing orange light: calibrating the board
- Flashing red light: signals that the user is attempting to extend or retract the actuator but the actuator is already either fully extended or retracted, respectively.

Troubleshooting:

- Always check wiring first for loose connections or short circuits; verify power source is a reliable 12V capable of delivering at least 10A.
- The FA-SYNC-2 will fail to synchronize if the sensor signal from one or more actuators is lost due to a bad connection or failure of sensor circuitry. The sensing time is 2 seconds.
- If actuators begin to move out of synchronous, or stop moving despite contrary commands, check the wiring and then repeat the calibration sequence.