

FA-MU-16-12-3
FORCE: 16Lbs (71N)

Actuator Wiring		
Color	Brown	Blue
Extend	-	+
Retract	+	-

TABLE		
NO.	Item	Detail
1	Model No.	FA-MU-16-12-3"
2	Stroke	76.2±3mm [3 in]
3	Voltage	12V DC
4	No Load Speed (mm/s)	18mm±10%
6	Full Load Speed (mm/s)	13mm±10%
7	No Load Current (mA)	≤200
8	Full Load Current (mA)	≤500
9	No Load Noise (dBA)(450mm)	≤61
10	Holding Force (Lbs) (N)	13.49Lbs (60N)
11	Ultimate Mechanical Static Holding Force (Lbs)(N)	23.62Lbs (105N)
12	IP Grade	IP54
13	Front mounting end	thru hole Ø4.10mm [Ø.16 in]
14	Rear mounting end	thru hole Ø4.10mm [Ø.16 in]

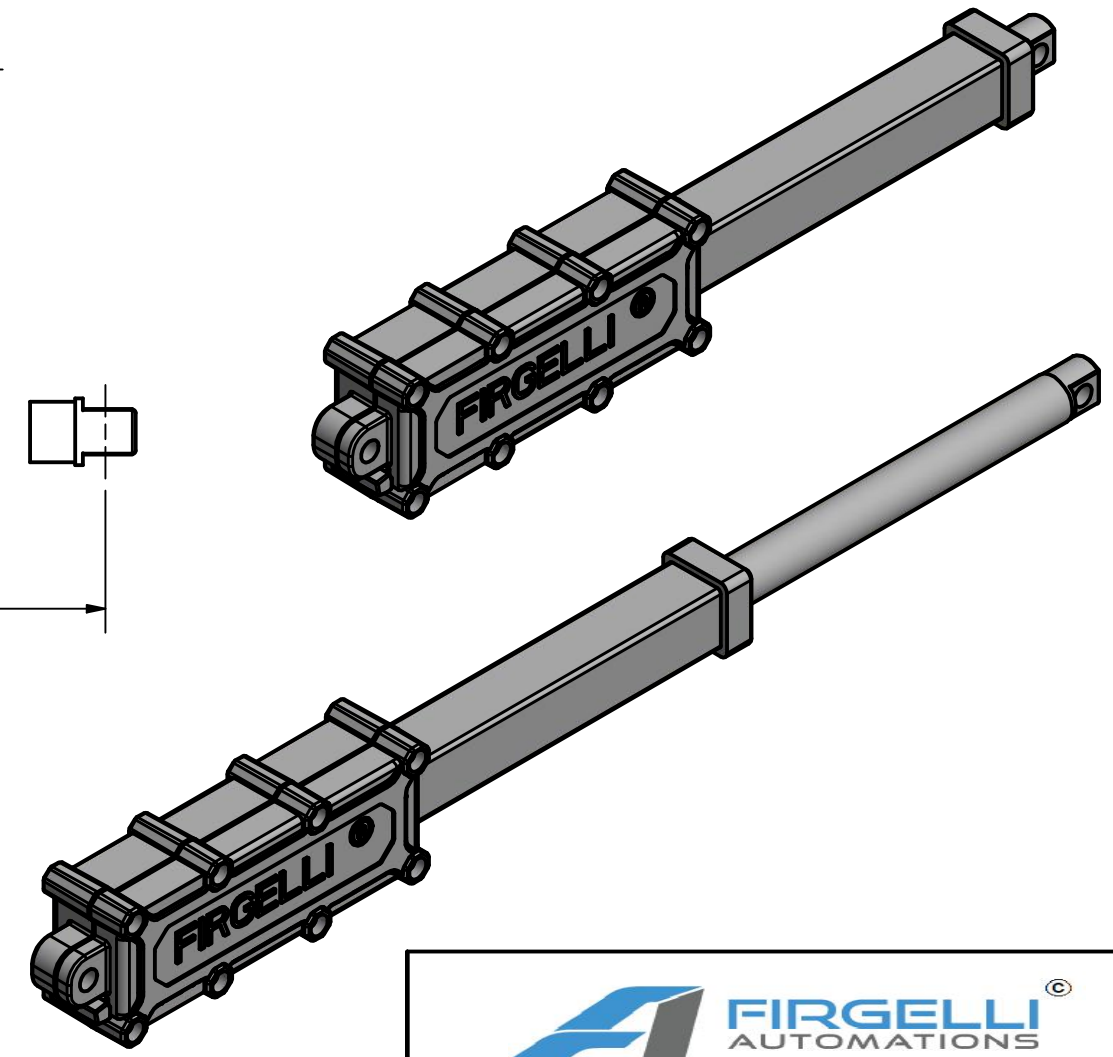
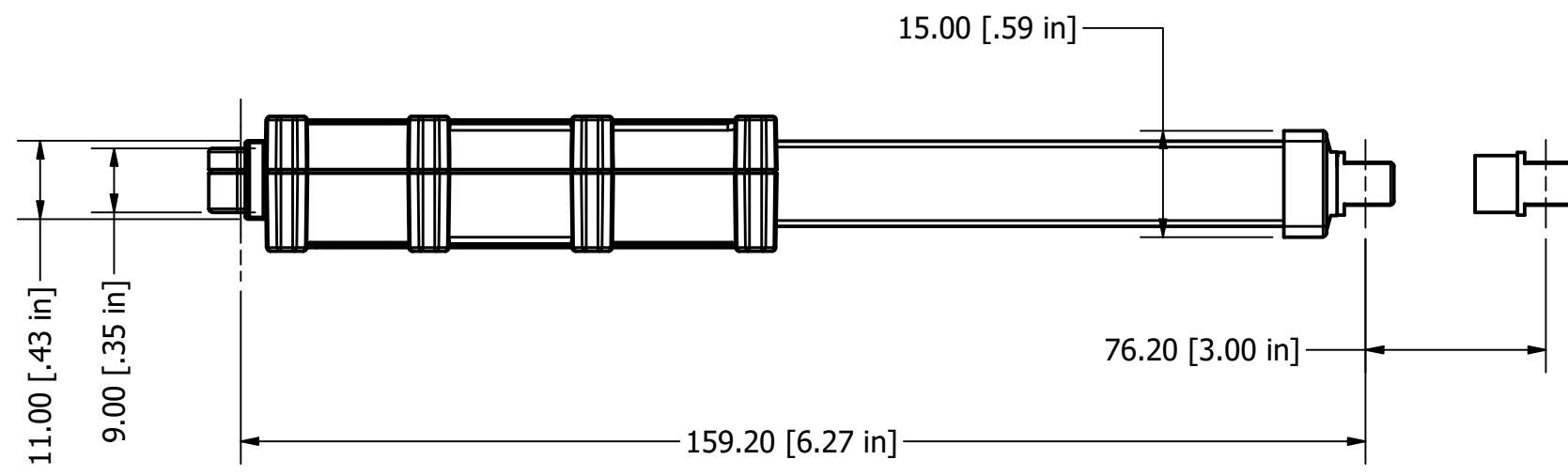
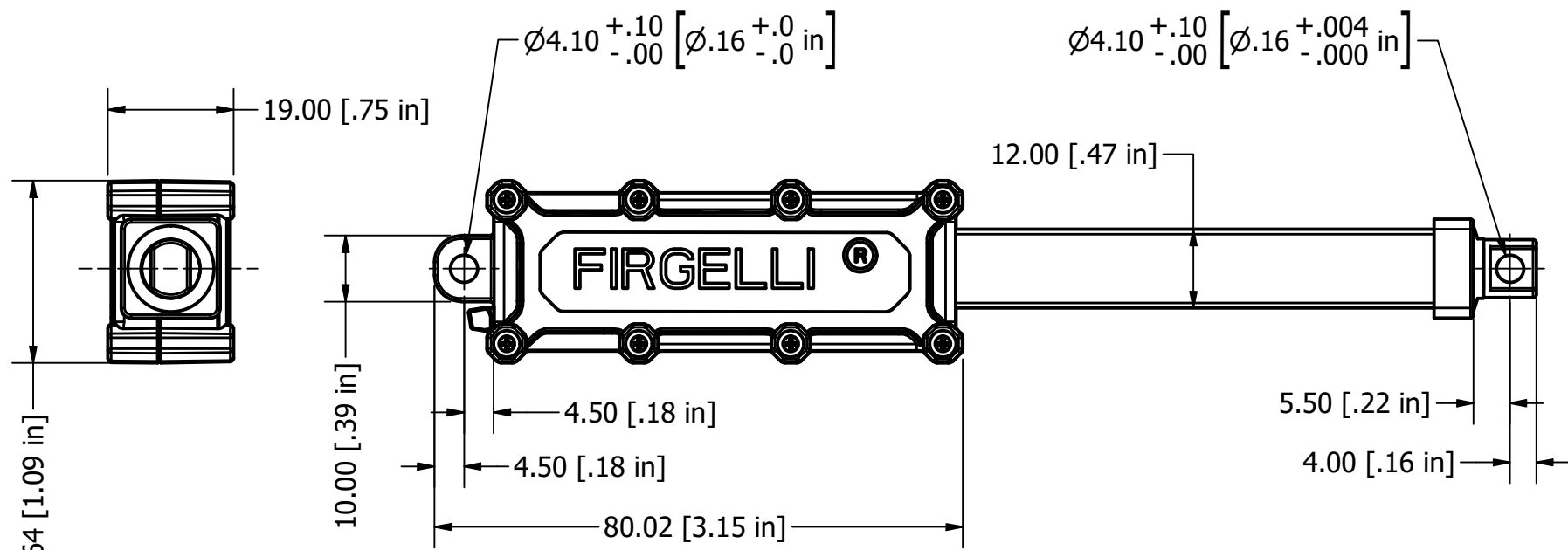

SIZE A3	DWG NO FA-MU-16-12-3	REV
SCALE 1 : 1	SHEET 1 OF 1	