

FA-U-330-12-2
FORCE: B motor(1500N)

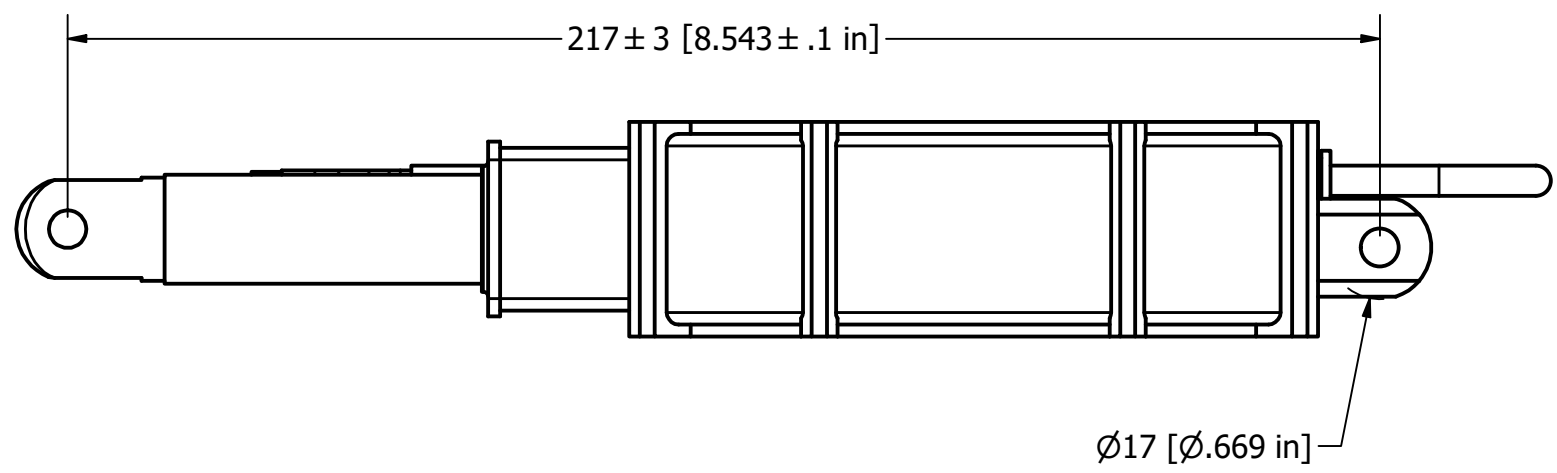
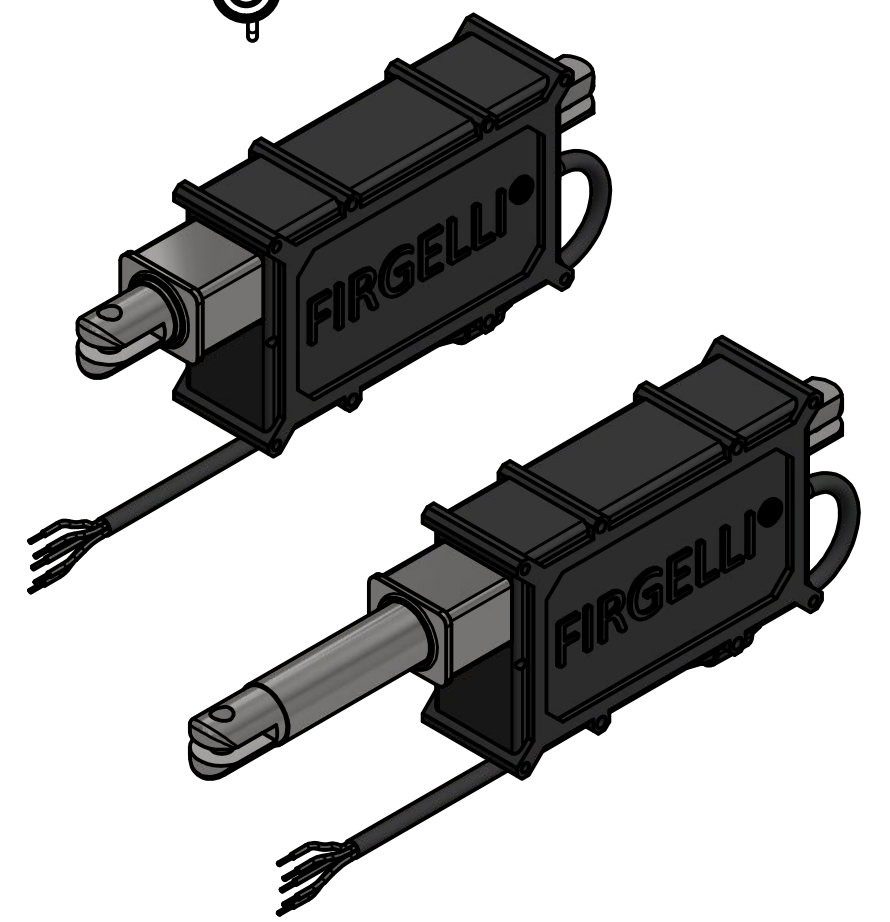
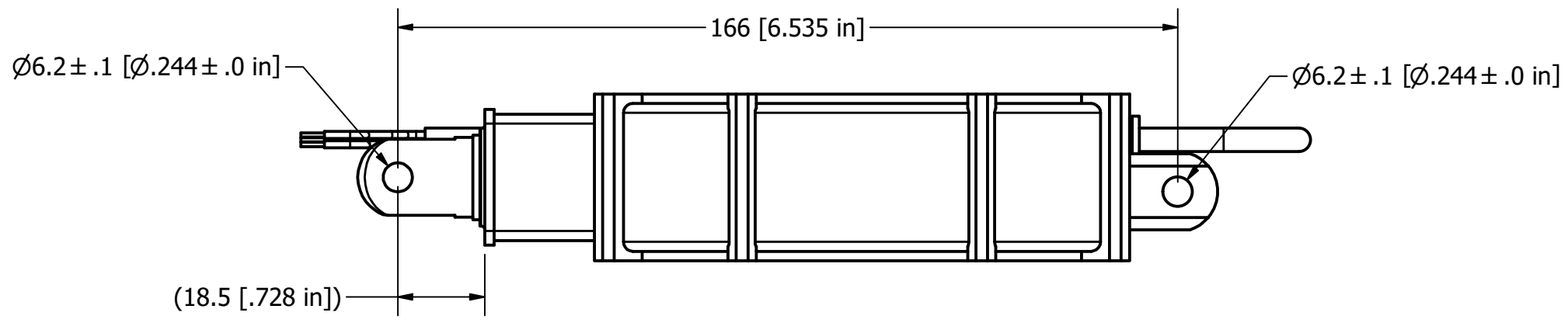
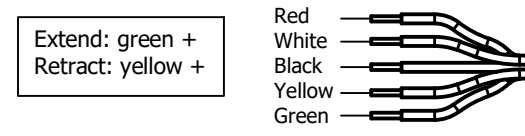
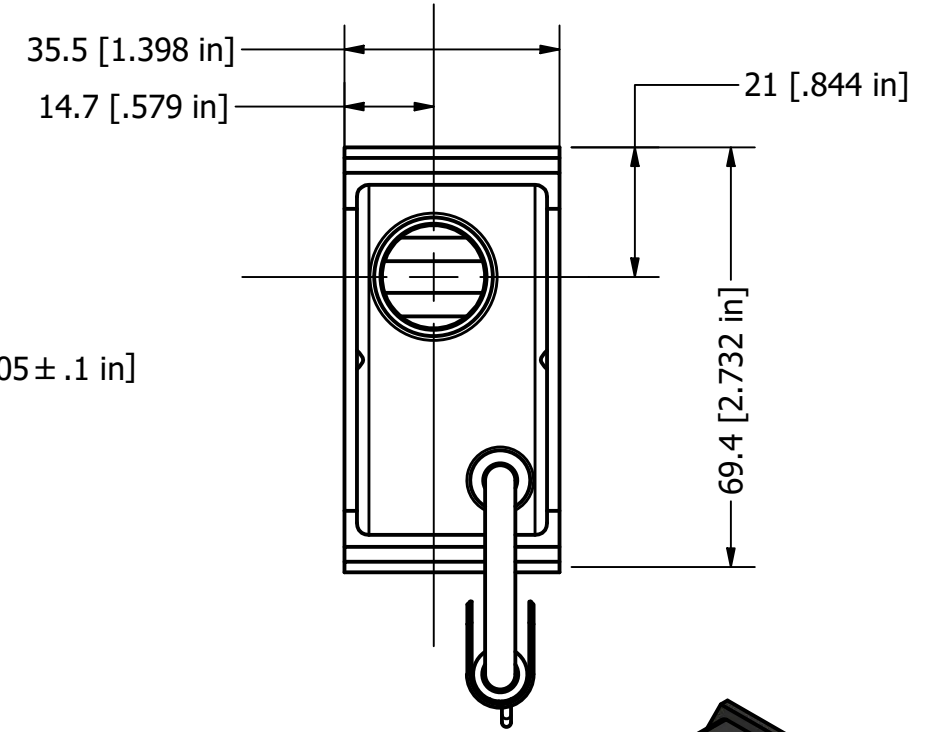
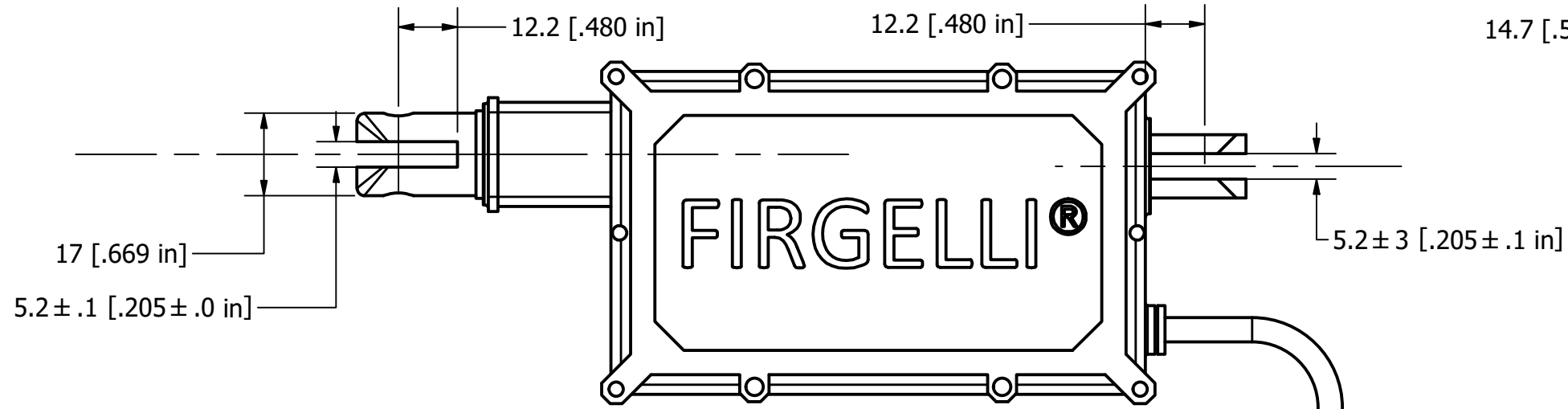

DRAWN	MR ADEBAYO	22/07/2022		
CHECKED				
QA			TITLE	
MFG			ACTUATOR	
APPROVED			SIZE	DWG NO
STROKE	2"		A3	Actuator Drawing 2in
			SCALE	REV
			1 : 1.25	SHEET 1 OF 2