

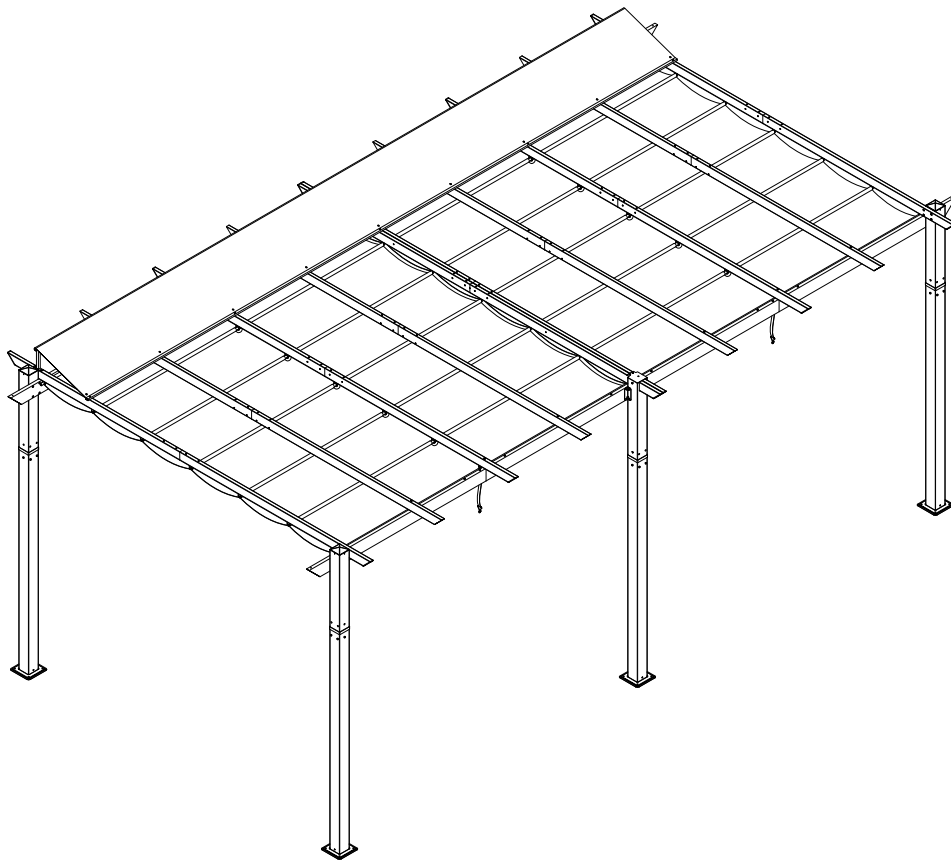

11' x 20' ALUMINUM RETRACTABLE PERGOLA ASSEMBLY MANUAL



MODEL#: LGMD1616

Missing part? Damaged? Contact us via email at
service@domioutdoorliving.com

www.domioutdoorliving.com

Pre-assembly



1. Two or more people are required for assembly.



2. You will need one or more stepladders.



3. Wearing protective gloves is recommended.



4. You may need a safety hat.



5. Please use a Phillips screw driver.



6. For ease of construction, you may need a drill.



7. You may need a safety goggle.



8. Do not fully tighten screws prior to complete assembly.

Warning & Attention

-Try to assemble this product on the flat ground, otherwise it is difficult to carry out;

-It would be much easier to assemble the product with three or more people;

-After assembly, please check whether all screws are tightened, to prevent parts from falling apart.

▲ Use bolts to secure the frame to the ground to against the strong wind.

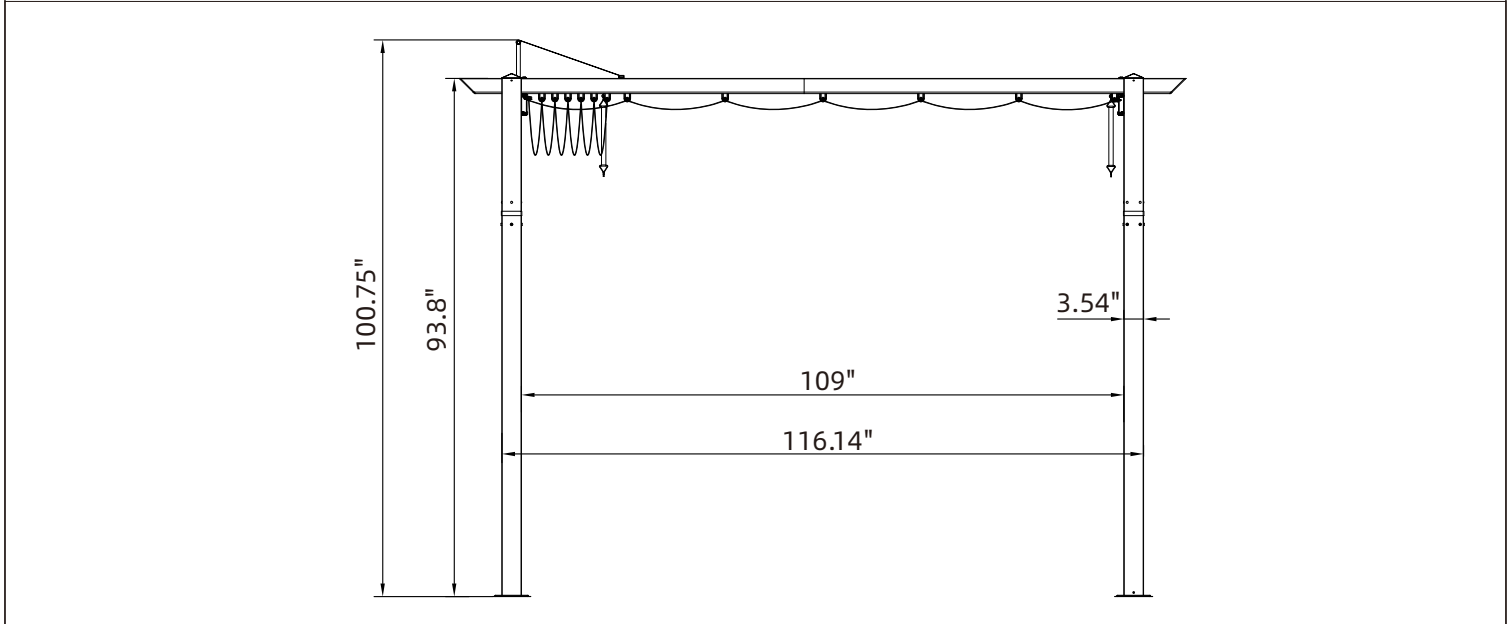
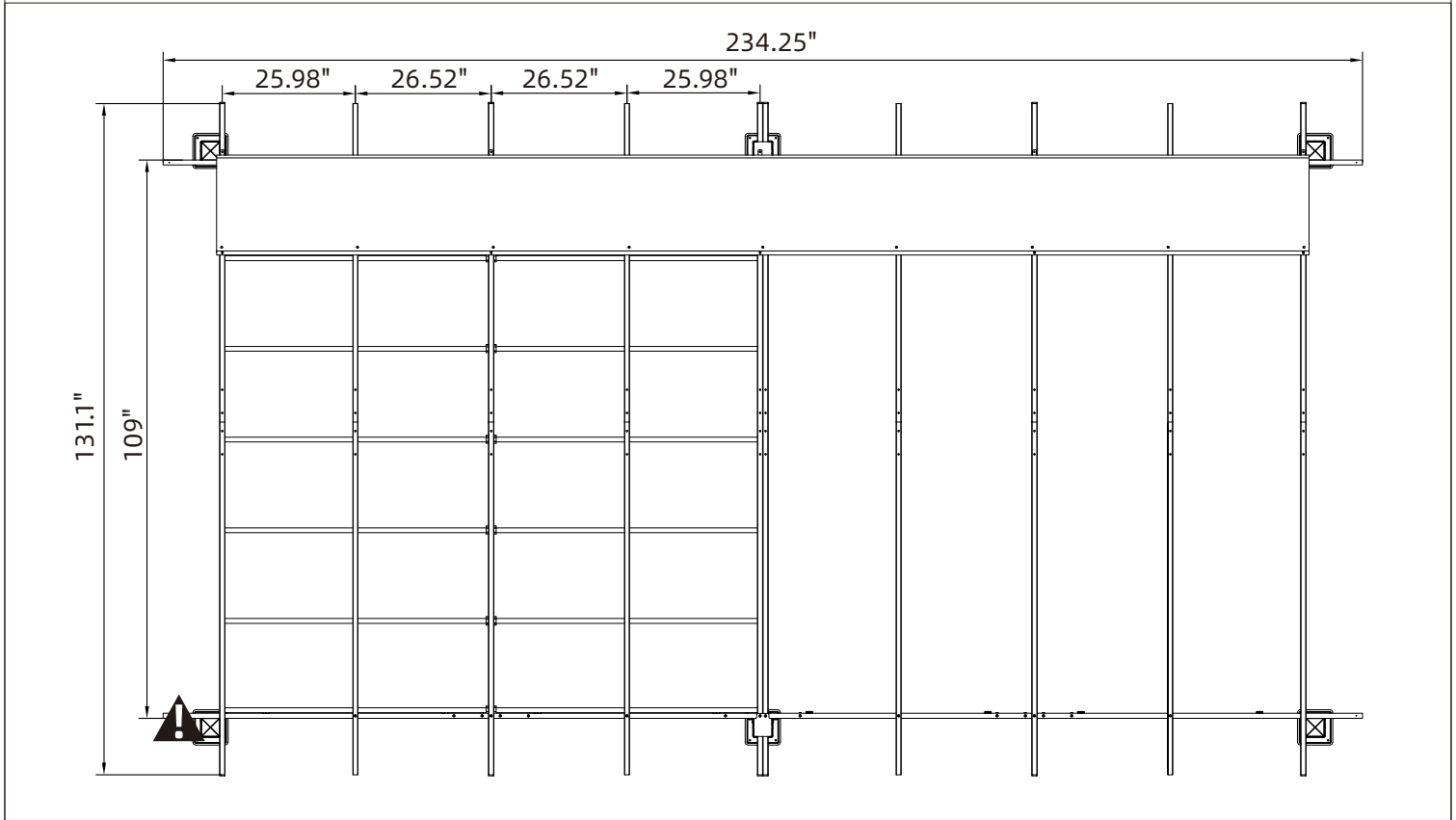
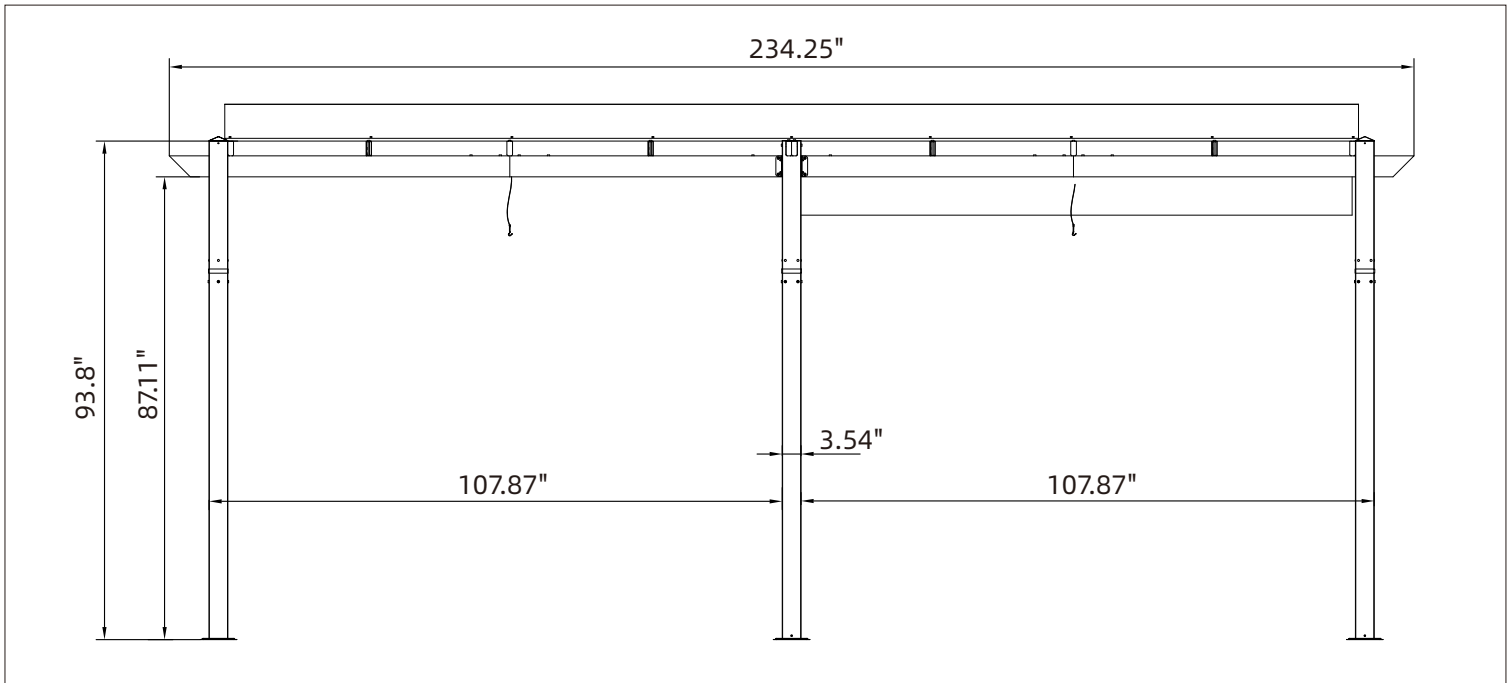

1

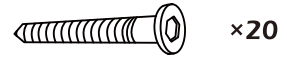
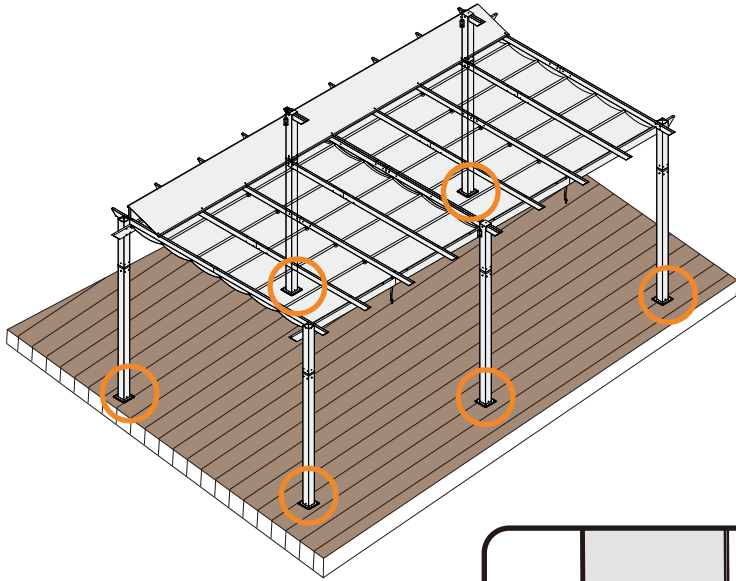

If the deck is hard wood and the depth of it is over 3 inch, you can use **5/16 in. x4 in. Structural Wood Screw** to mount the gazebo.

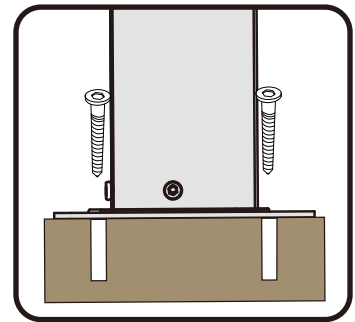
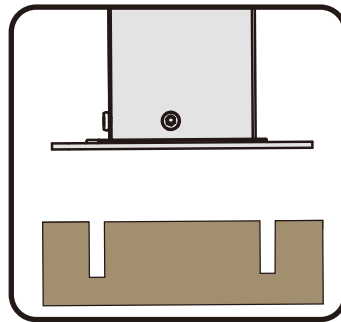

2

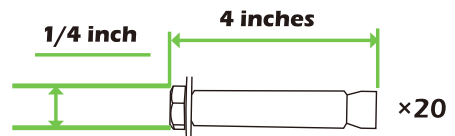
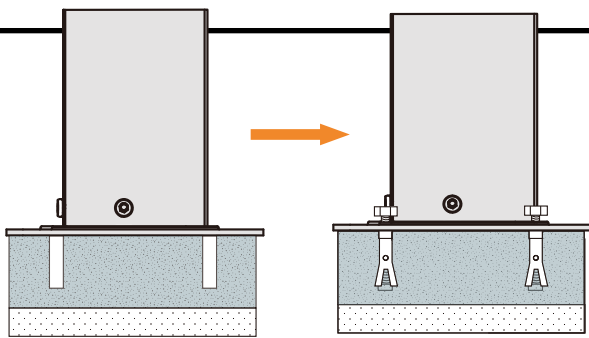

If the ground is concreted and the depth of it is over 3 inch, you can use 1/4 inch expansion bolts to mount the gazebo

3



Or you can make a concrete footing for gazebo, **15x15x15 inches** is recommended. use expansion bolts to mount the gazebo like (2) shows.

IMPORTANT:
Anchor is not recommended

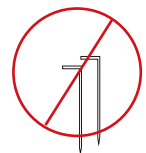

L=90x90x1760mm

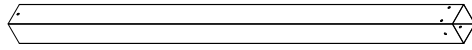

(A) 6x Pole

L=90x90x720mm

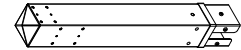

(A1) 2x Pole Connector

L=90x90x720mm

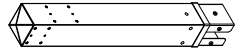

(A2) 2x Pole Connector

L=90x90x722mm

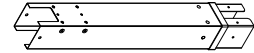

(A3) 2x Pole Connector

L=100x25x1630mm

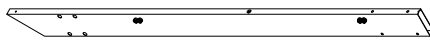

(C) 1x Beam

L=100x25x1350mm



(C1) 1x Beam

L=100x25x1350mm

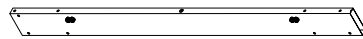

(C2) 1x Beam

L=100x25x1630mm

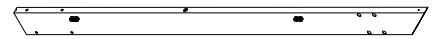

(C3) 1x Beam

L=100x25x1630mm

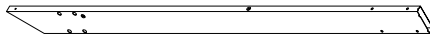

(D) 1x Beam

L=100x25x1350mm

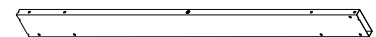

(D1) 1x Beam

L=100x25x1350mm

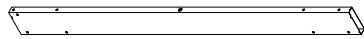

(D2) 1x Beam

L=100x25x1630mm



(D3) 1x Beam

L=70x27x1755mm

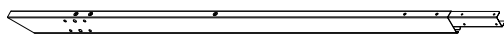

(E) 1x Crossbeam

L=70x27x1750mm

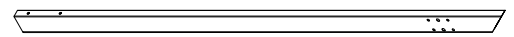

(E1) 1x Crossbeam

L=70x27x1755mm



(E2) 1x Crossbeam

L=70x27x1750mm

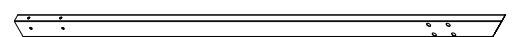

(E3) 1x Crossbeam

L=70x27x1755mm

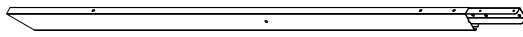

(F) 1x Crossbeam

L=70x27x1750mm

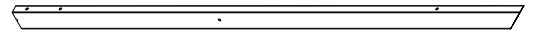

(F1) 1x Crossbeam

L=70x27x1755mm

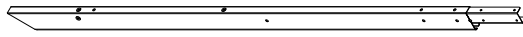

(F2) 1x Crossbeam

L=70x27x1750mm

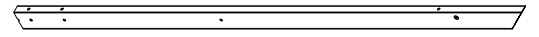

(F3) 1x Crossbeam

L=70x27x1755mm

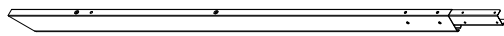

(G) 2x Crossbeam

L=70x27x1750mm

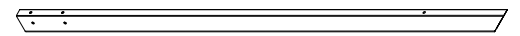

(G1) 2x Crossbeam

L=70x25x1755mm

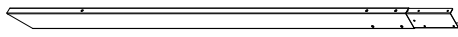

(H) 4x Crossbeam

L=70x25x1750mm

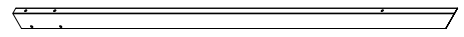

(H1) 4x Crossbeam

L=Ø16x1385mm



(J) 2x Canopy Bar

L=Ø16x1400mm



(J1) 1x Canopy Bar

L=Ø16x1400mm



(J2) 1x Canopy Bar

L=Ø16x1400mm



(J3) 1x Canopy Bar

L=Ø16x1400mm



(J4) 1x Canopy Bar

L=Ø16x1385mm



(J5) 2x Canopy Bar

L=20x10x1390mm















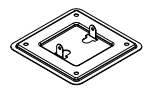
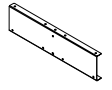
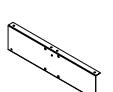
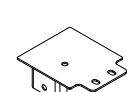
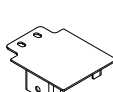
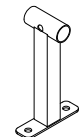

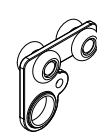

(K) 2x Canopy Bar

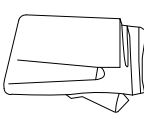
L=20x10x1390mm

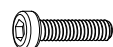

(K1) 1x Canopy Bar

Part list

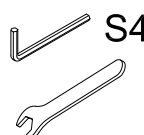
<p>L=20x10x1410mm</p>  <p>(K2) 1x Canopy Bar</p>	<p>L=∅19x1360mm</p>  <p>(L) 12x Canopy Bar</p>		
<p>L=∅19x1360mm</p>  <p>(L1) 12x Canopy Bar</p>	 <p>(B) 6x Plate</p>	 <p>(M) 4x Solidifying Bar</p>	
 <p>(M1) 2x Solidifying Bar</p>	 <p>(N) 1x Joint Cover</p>	 <p>(N1) 1x Joint Cover</p>	 <p>(P) 5x Canopy support stand</p>
 <p>(Q) 4x Bracket</p>	 <p>(R) 2x Rope</p>	 <p>(S) 2x Pulley Hook</p>	 <p>(S1) 10x Pulley Hook</p>
 <p>(S2) 24x Pulley Hook</p>	 <p>(T) 32x Screw Cap</p>	 <p>(U) 2x Canopy</p>	 <p>(U1) 1x Small canopy</p>
 <p>(V) 12x Anchor Stakes</p>	 <p>M6x16</p> <p>(1) 175x</p>	 <p>M6x20</p> <p>(2) 32x</p>	 <p>M6x28</p> <p>(3) 14x</p>
 <p>M6x35</p> <p>(4) 8x</p>	 <p>M6x65</p> <p>(5) 3x</p>	 <p>M6x85</p> <p>(6) 16x</p>	 <p>S4</p> <p>(7) 1x</p>

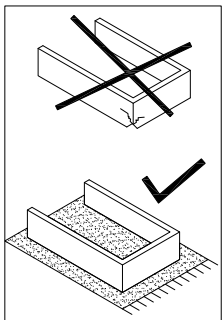

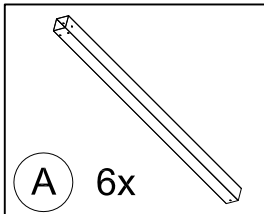

A 6x

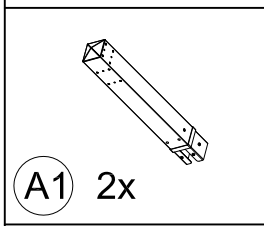

A1 2x

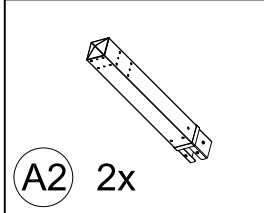

A2 2x

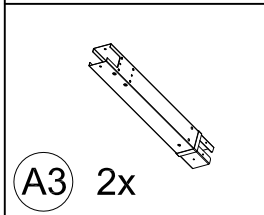

A3 2x

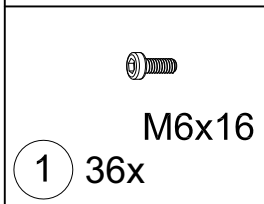

1 M6x16
36x

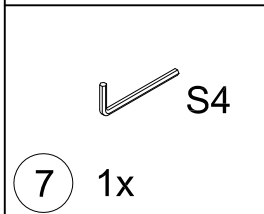

7 S4
1x

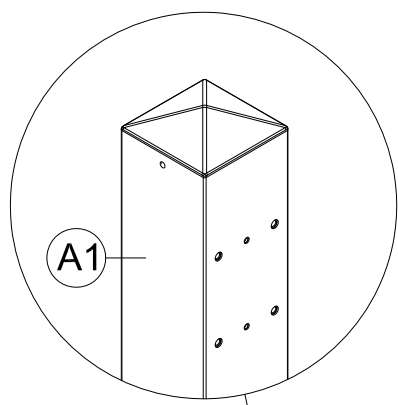

A1

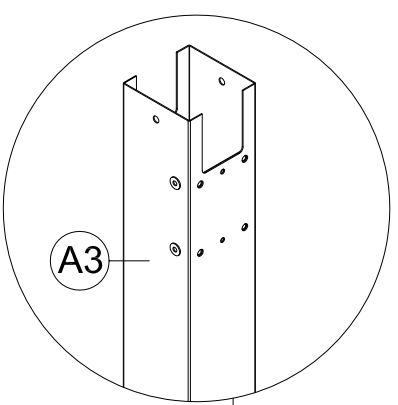

A3

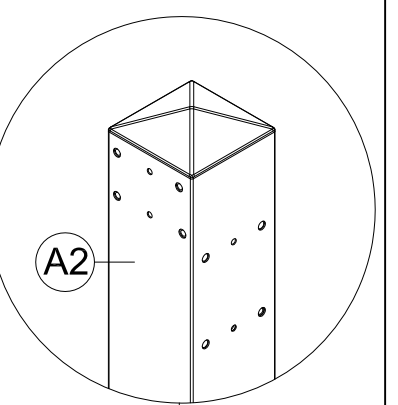

A2

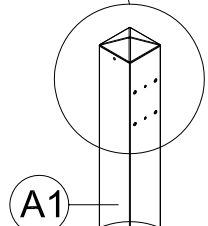

A1

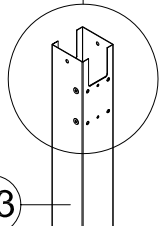

A3

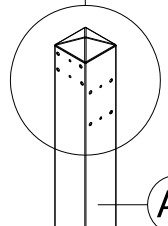

A2

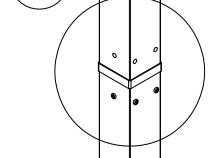

A

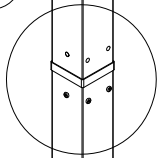

A

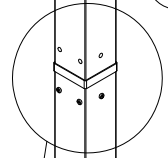

A

x 2

x 2

x 2

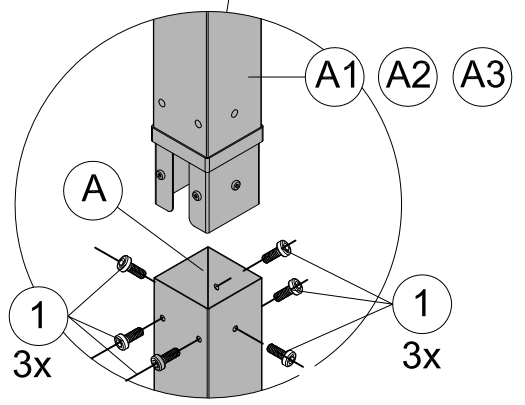

1
3x

1
3x

Step 1:

- ① Connect Part #A and Part #A1 (#A2, #A3) with 6 Bolts 1# as shown.
- ② Repeat the above procedures to assemble the other 3 posts.

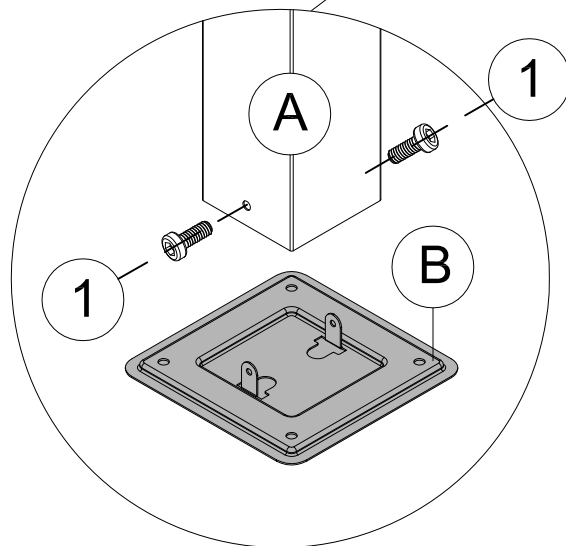
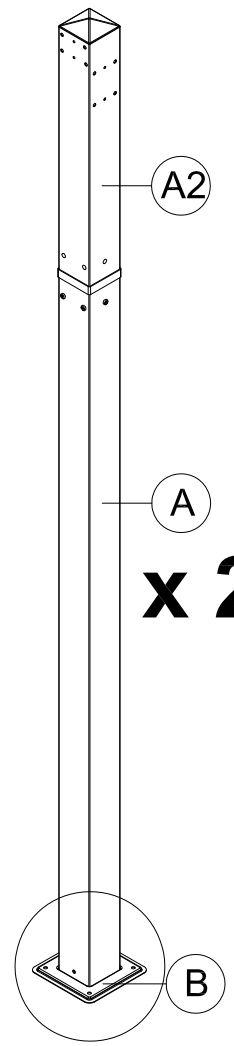
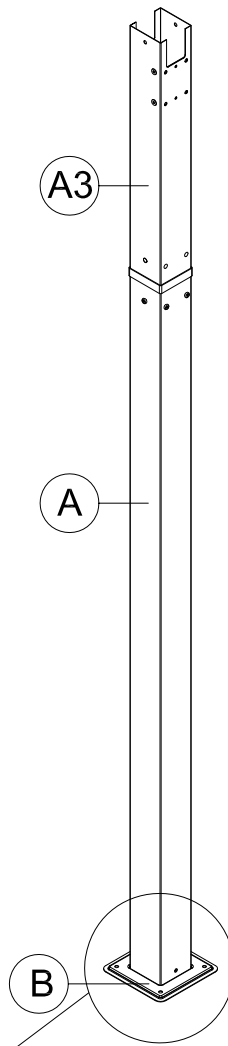
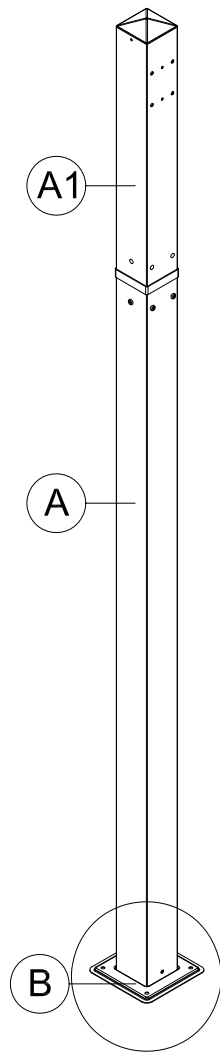
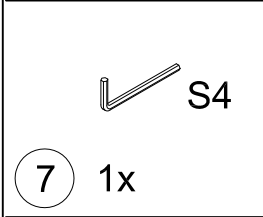
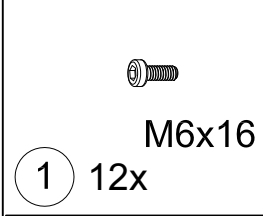
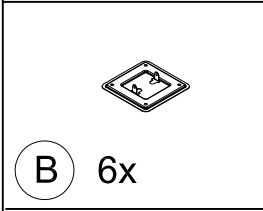
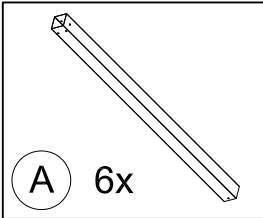

Step 2:

- ① Connect Part #A and Part #B with 2 Bolts 1# as shown.
- ② Repeat the above procedures to assemble the other 5 Plates.

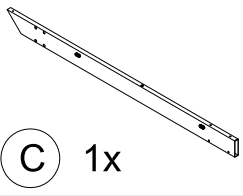

C 1x

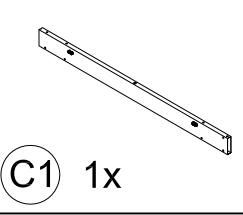

C1 1x

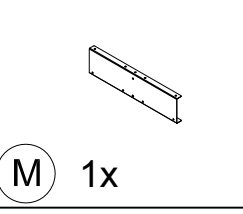

M 1x

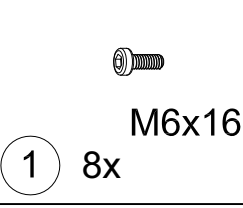

1 8x

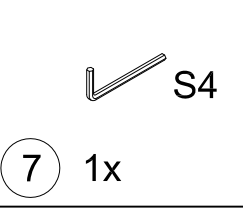

7 1x

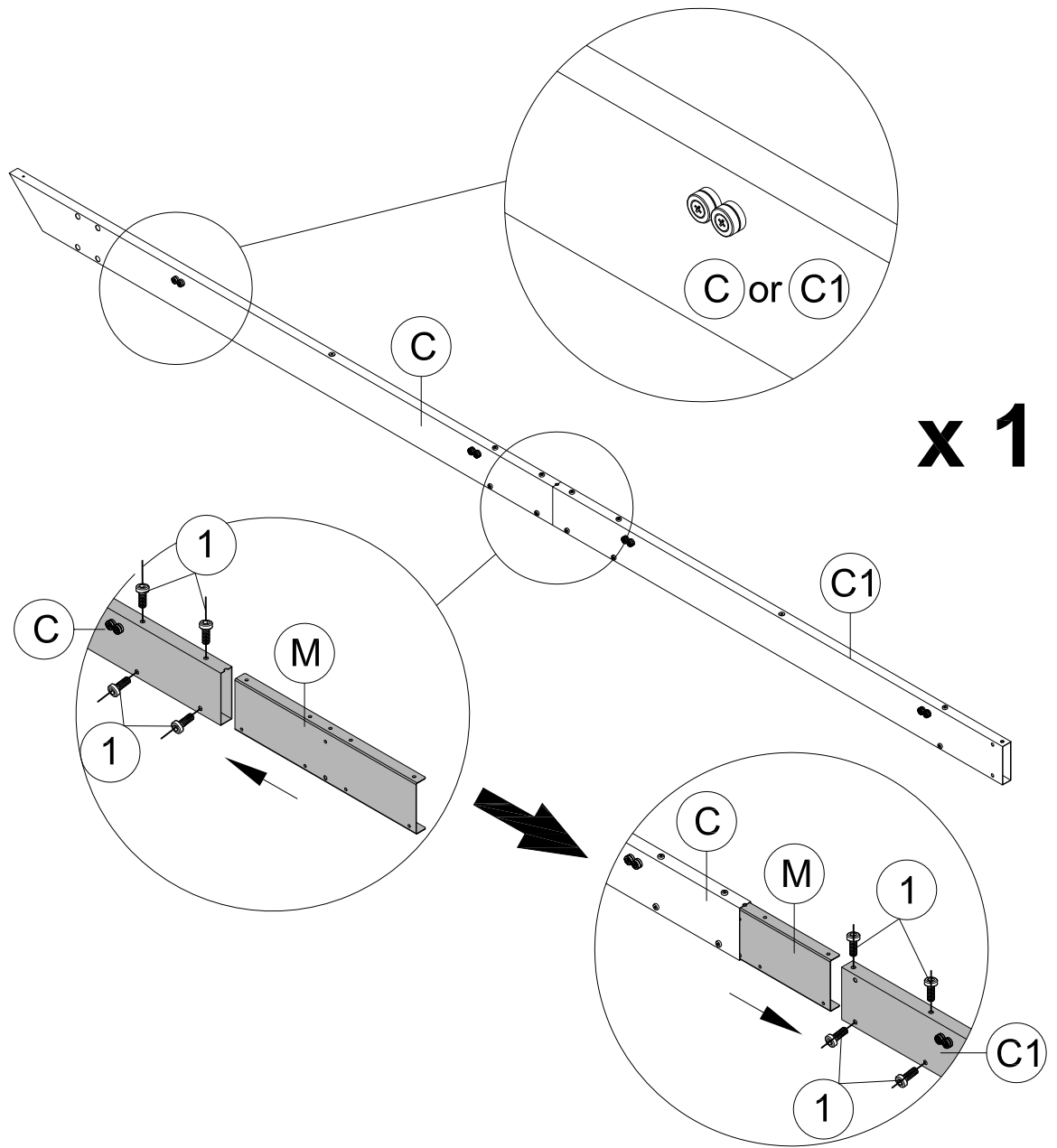

Step 3:

- ① Push #M into Part #C in the direction indicated by the arrow, then Connect Part #M and Part #C with 4 Bolts 1# as shown.
- ② Push M connected with C into C1 in the direction indicated by the arrow, then Connect Part #M and Part #C1 with 4 Bolts 1# as shown.

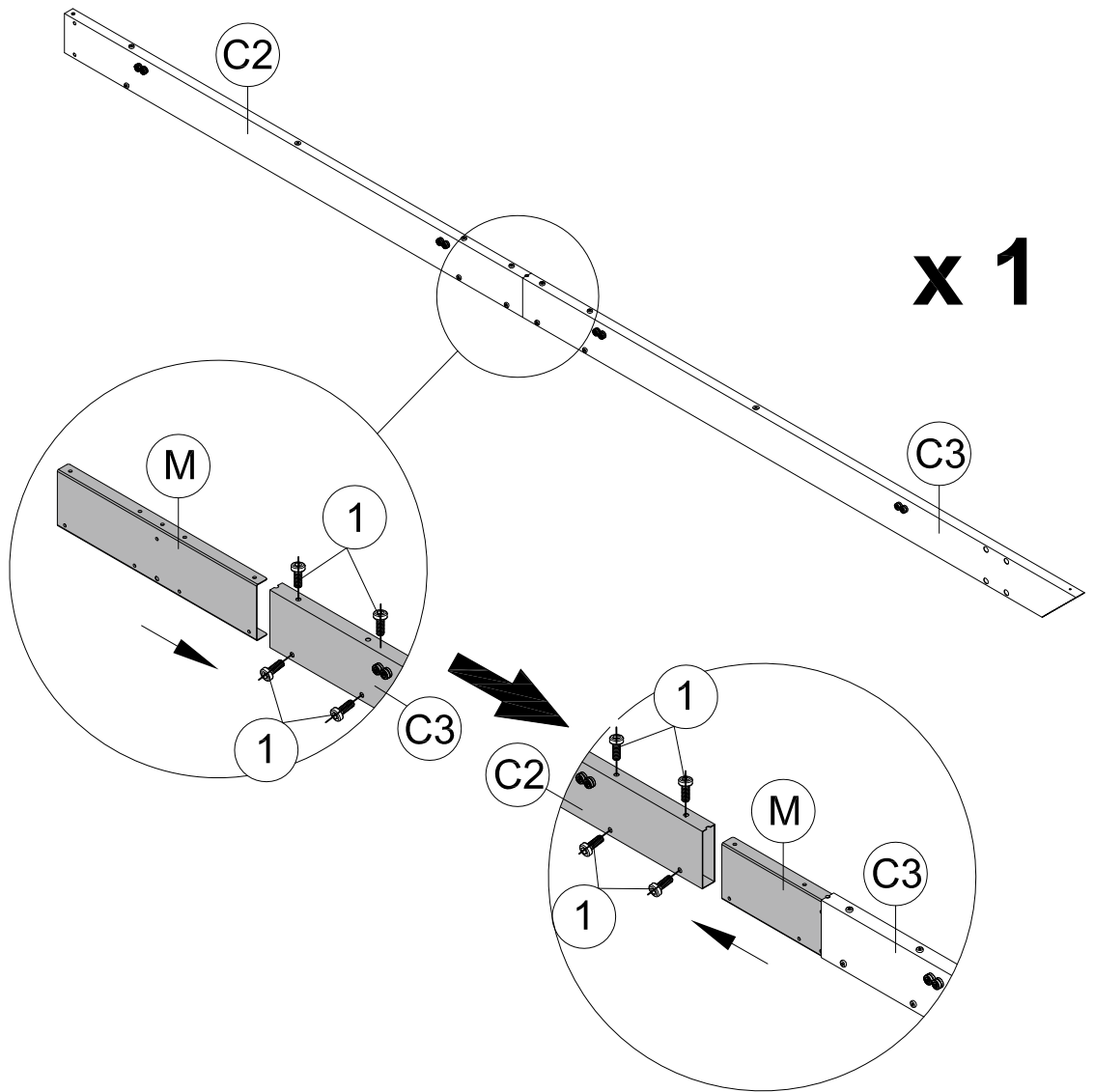
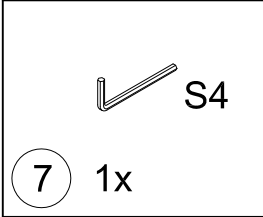
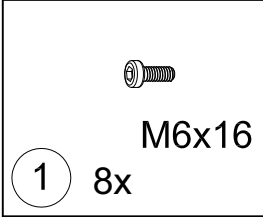
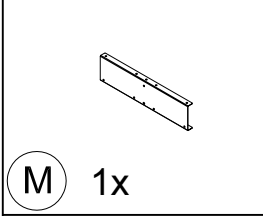
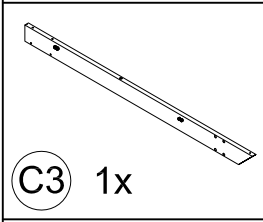
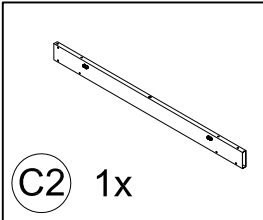

Step 4:

- ① Push #M into Part #C3 in the direction indicated by the arrow, then Connect Part #M and Part #C3 with 4 Bolts 1# as shown.
- ② Push M connected with C3 into C2 in the direction indicated by the arrow, then Connect Part #M and Part #C2 with 4 Bolts 1# as shown.

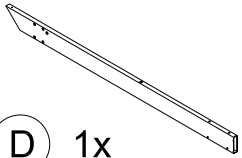

D 1x

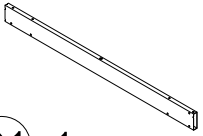

D1 1x

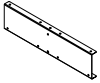

M 1x



M6x16

1 8x



S4

7 1x

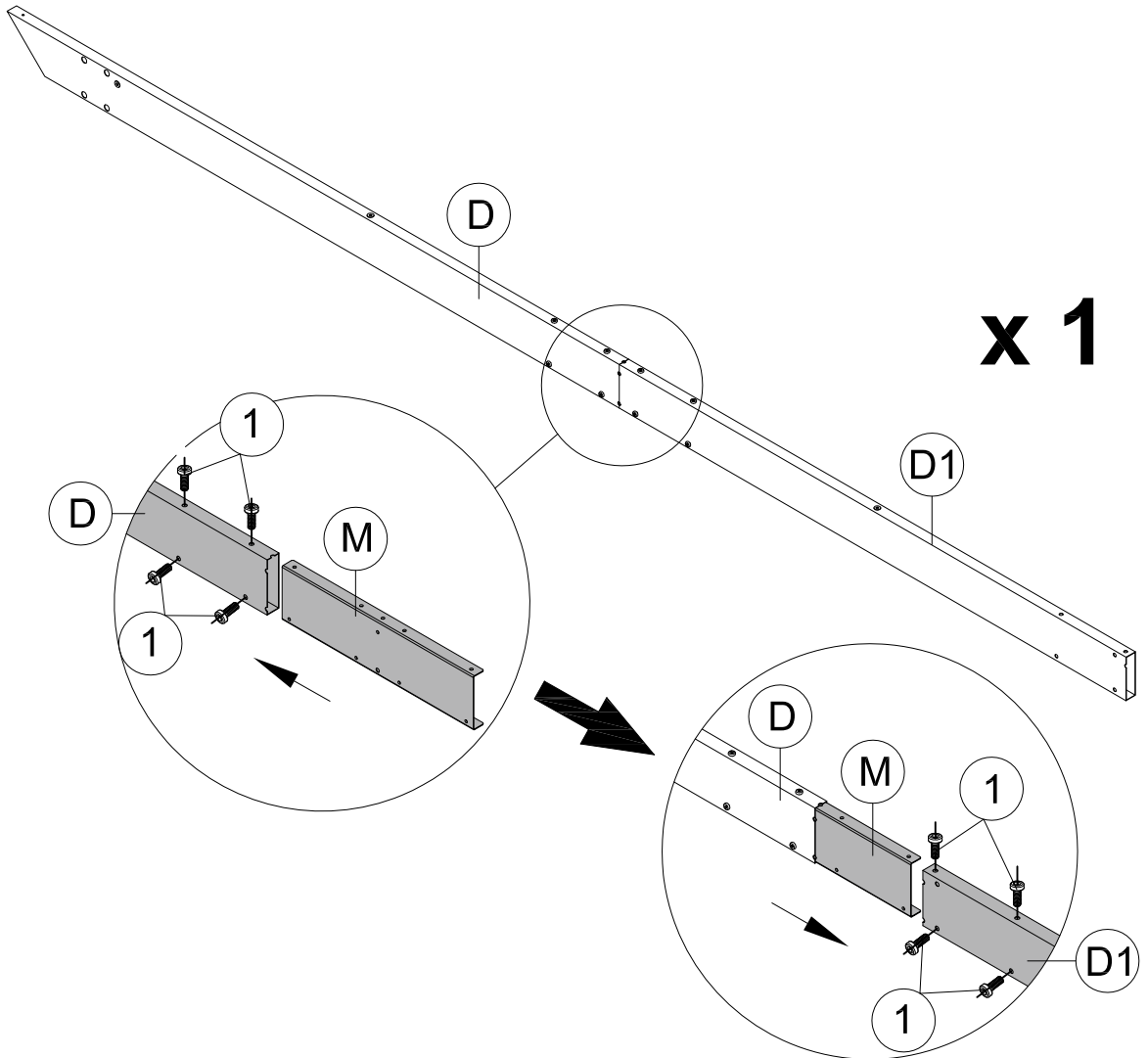

Step 5:

- ① Push #M into Part #D in the direction indicated by the arrow, then Connect Part #M and Part #D with 4 Bolts 1# as shown.
- ② Push M connected with D into D1 in the direction indicated by the arrow, then Connect Part #M and Part #D1 with 4 Bolts 1# as shown.

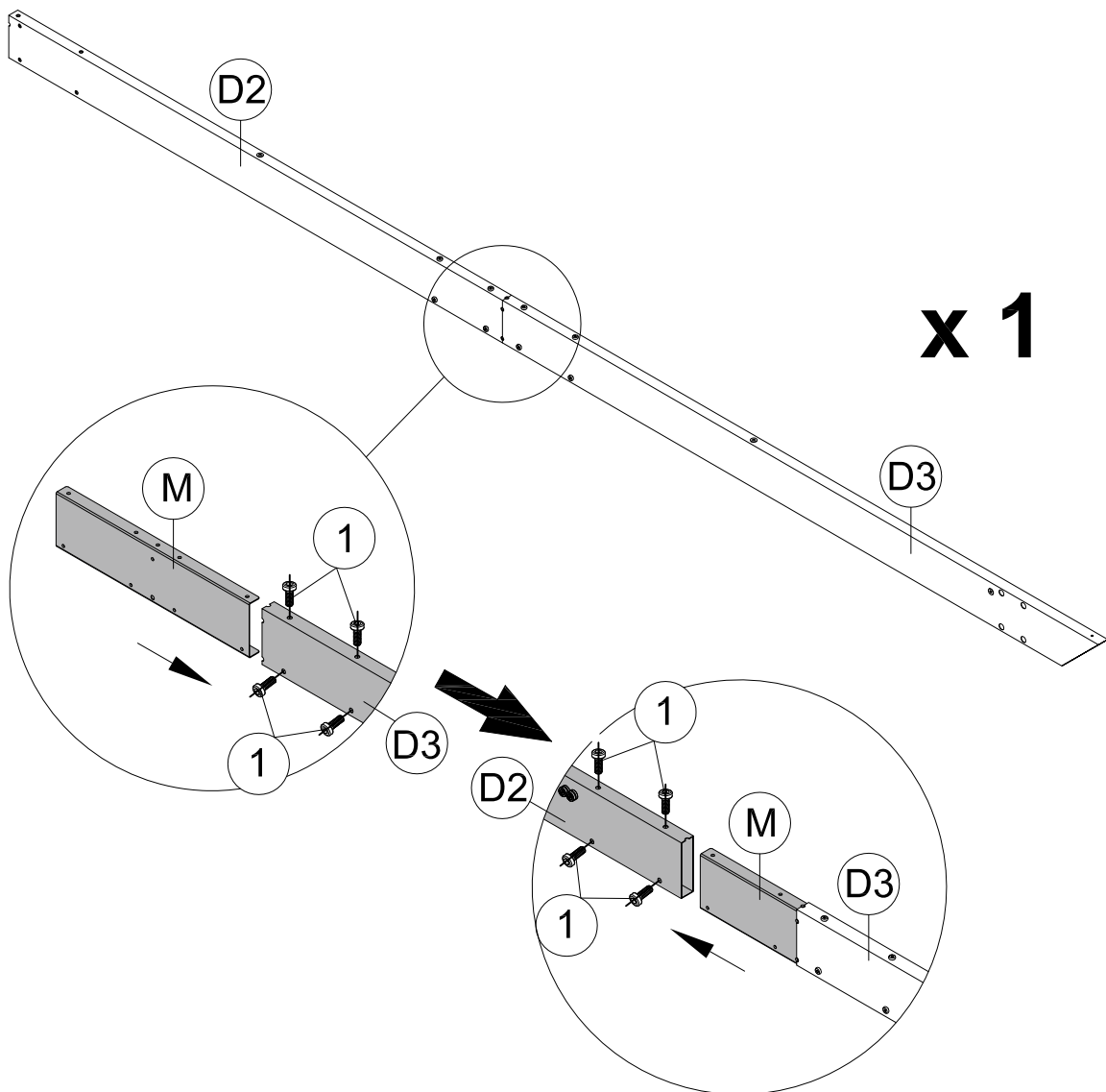
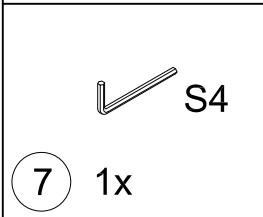
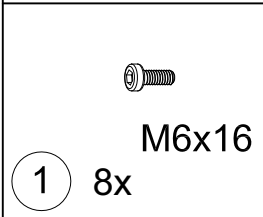
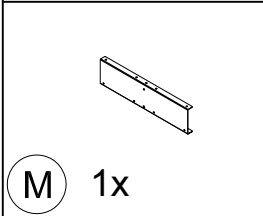
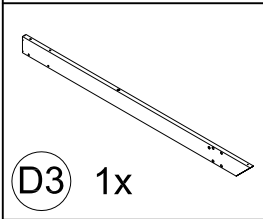
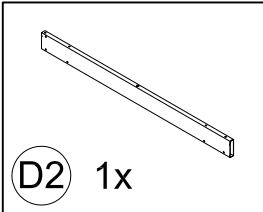

Step 6:

- ① Push #M into Part #D3 in the direction indicated by the arrow, then Connect Part #M and Part #D3 with 4 Bolts 1# as shown.
- ② Push M connected with D3 into D2 in the direction indicated by the arrow, then Connect Part #M and Part #D2 with 4 Bolts 1# as shown.

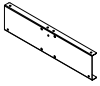

(M1) 1x



M6x16

(1) 4x



S4

(7) 1x

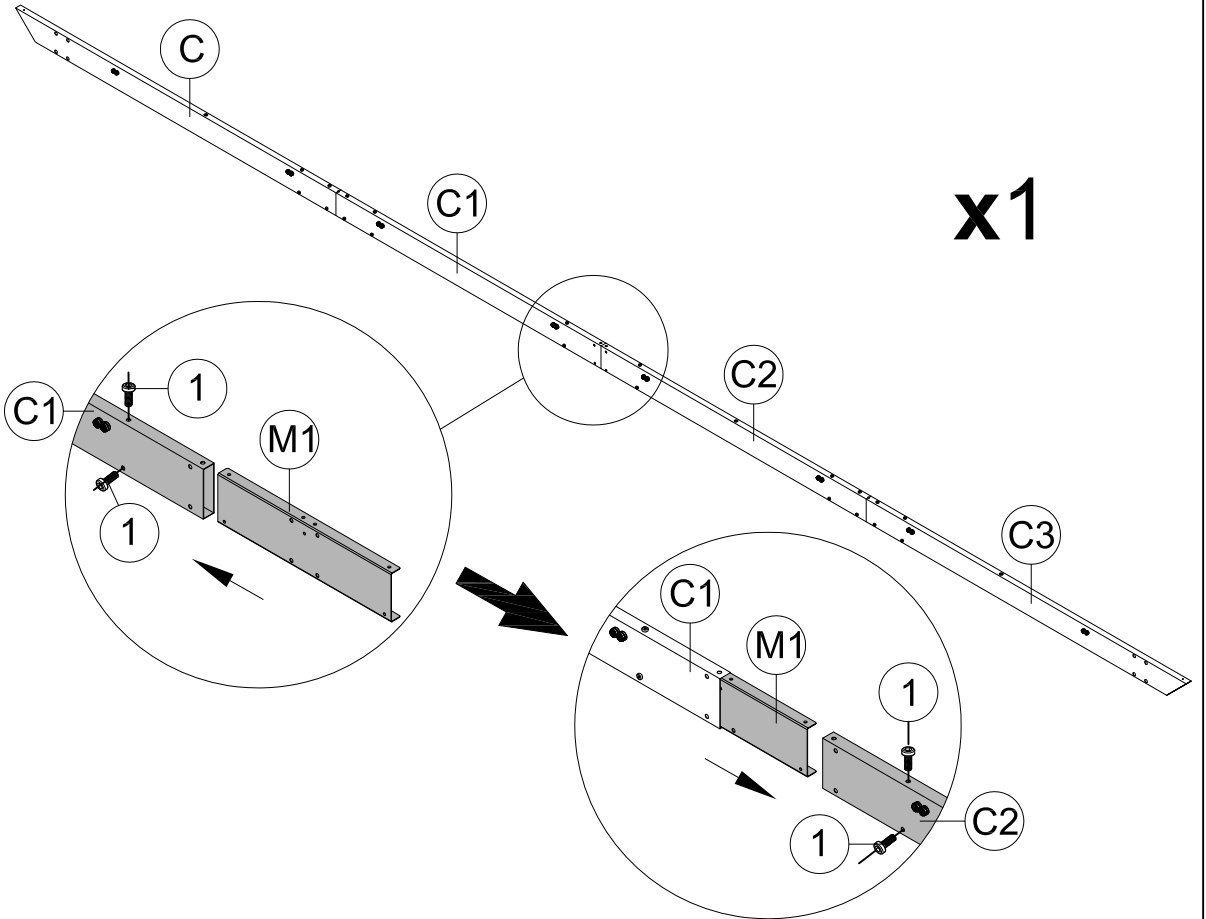

Step 7:

- ① Push #M1 into Part #C1 in the direction indicated by the arrow, then Connect Part #M1 and Part #C1 with 2 Bolts 1# as shown.
- ② Push M1 connected with C1 into C2 in the direction indicated by the arrow, then Connect Part #M1 and Part #C2 with 2 Bolts 1# as shown.

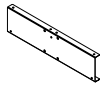

(M1) 1x



M6x16

(1) 4x



S4

(7) 1x

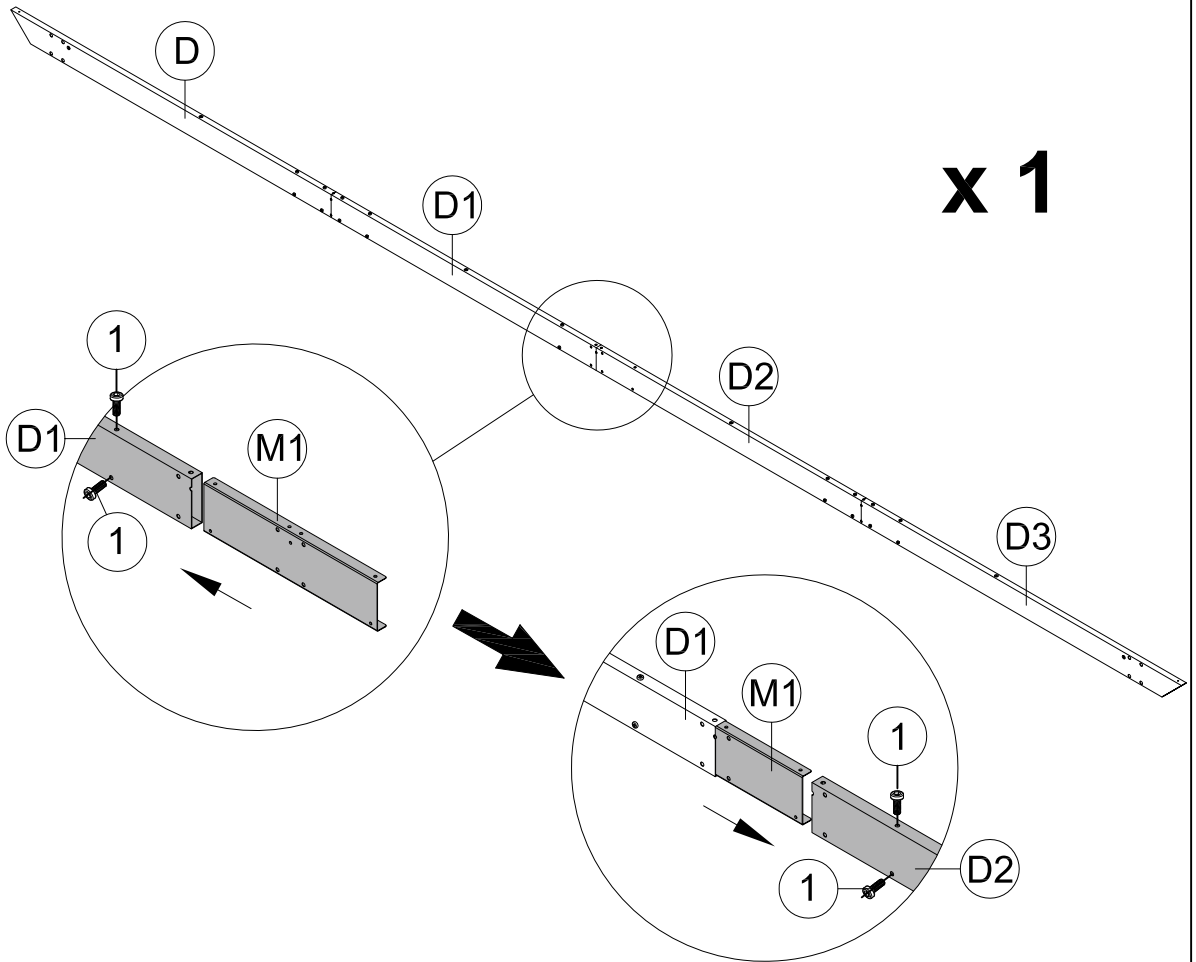

Step 8:

- ① Push #M1 into Part #D1 in the direction indicated by the arrow, then Connect Part #M1 and Part #D1 with 2 Bolts 1# as shown.
- ② Push M1 connected with D1 into D2 in the direction indicated by the arrow, then Connect Part #M1 and Part #D2 with 2 Bolts 1# as shown.



T 16x

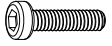

M6x20

2 16x



S4

7 1x

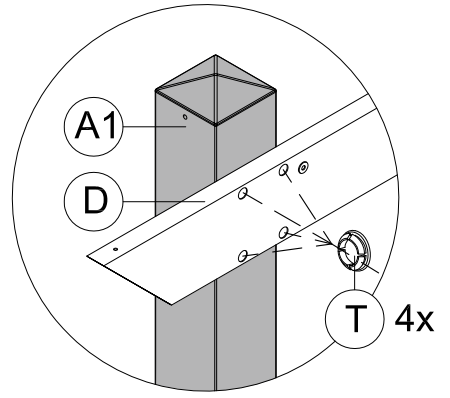
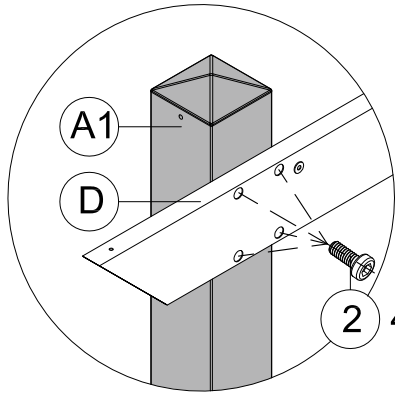

Step 9:

- ① Connect Part #A1(A2) and Part #D(D3/ C/ C3) with 4 Bolt #2 as shown.
- ② Put 4 plastic covers #T on the Bolt #2 as shown.

⚠ Be aware of the connecting position of the poles and beams.

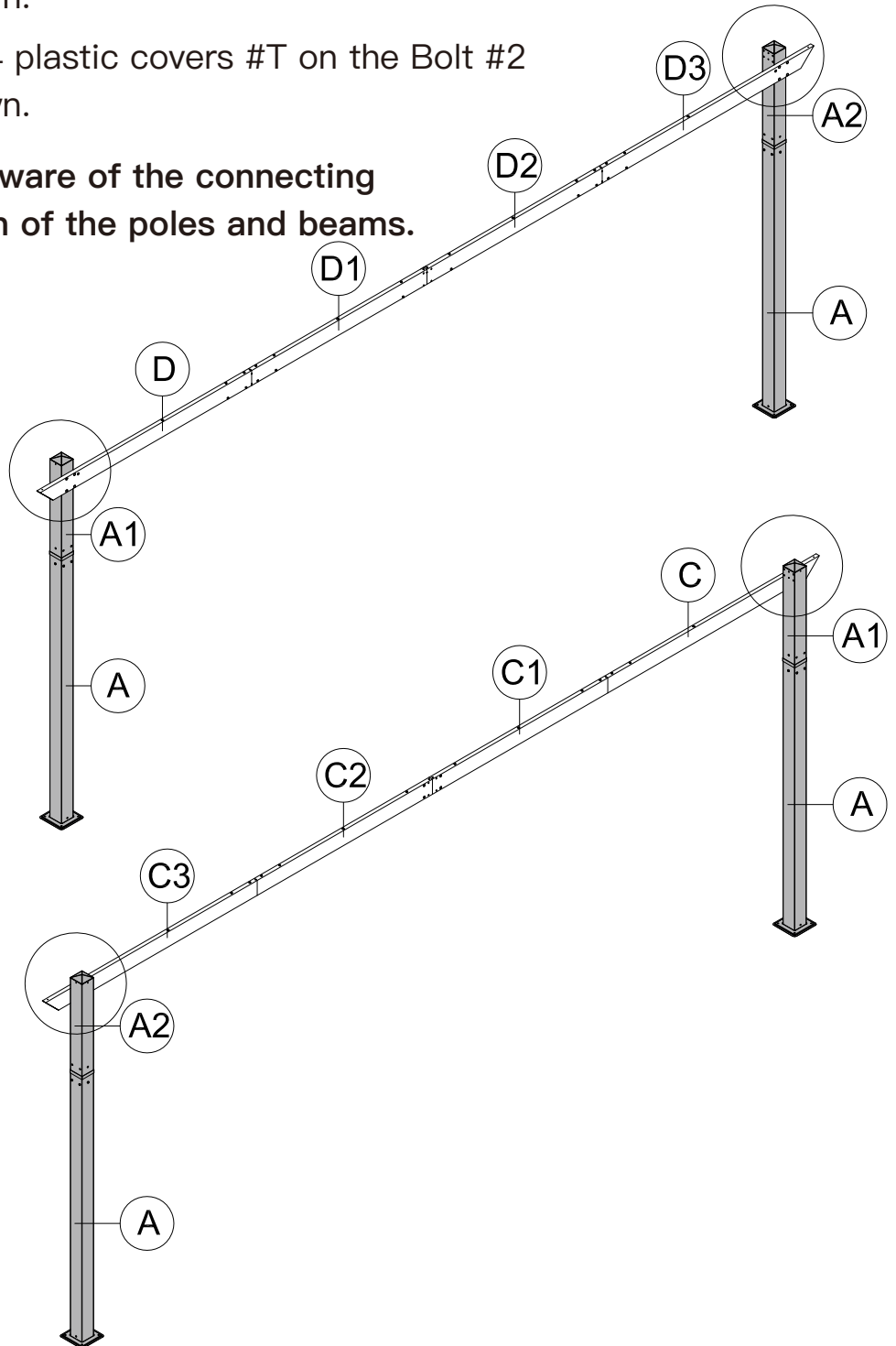



Q 4x



M6x16

1 16x

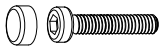

M6x35

4 8x



S4

7 1x

Step 10:

① Connect Part #A3 and the joint of Part #D1 & D2, Part #C1 & C2 with 4 Bolt 4# as shown.

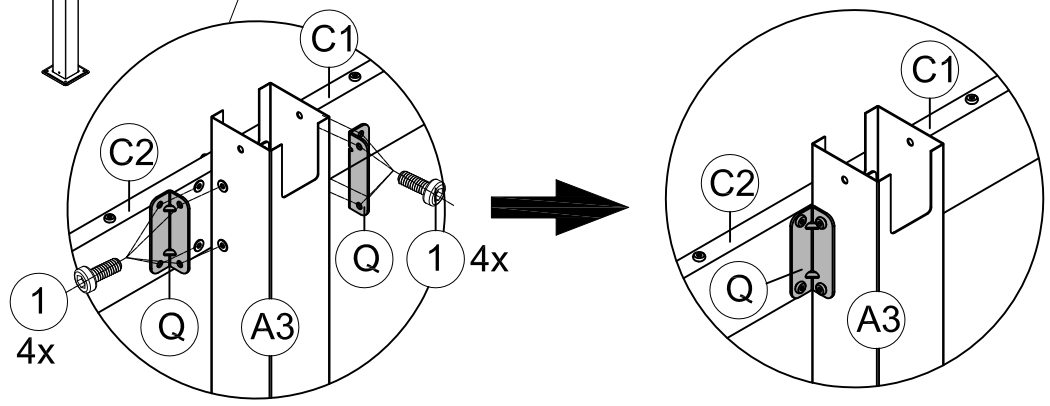
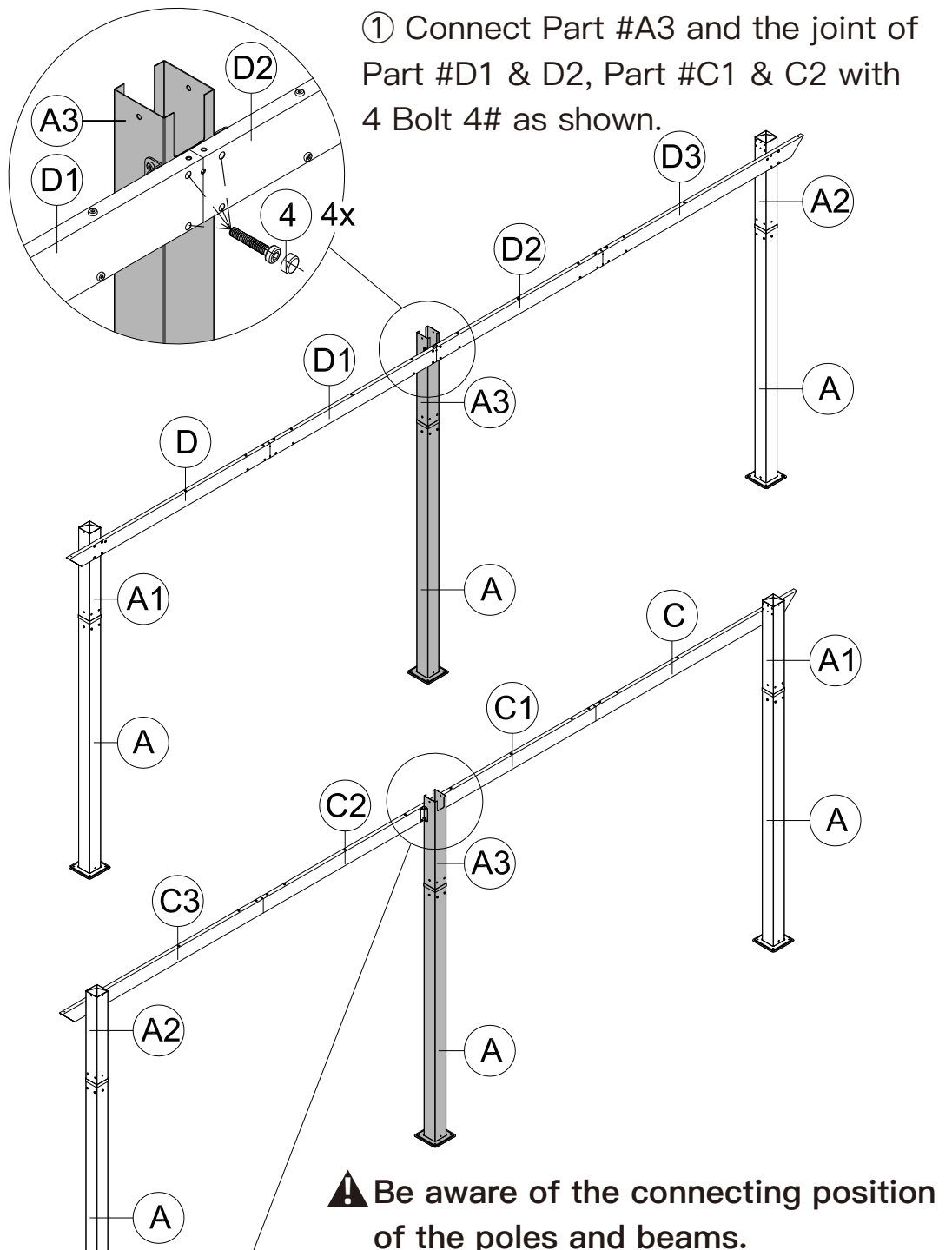

② Place Part Q on Part A3 and Part C2/ C1/ D1/ D2. Secure with 4 Bolt #1 as shown.

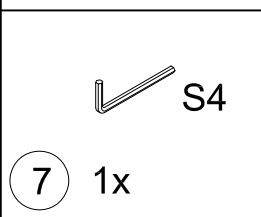
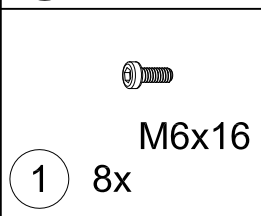
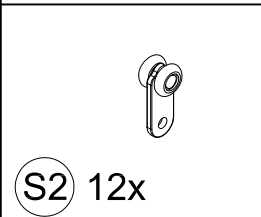
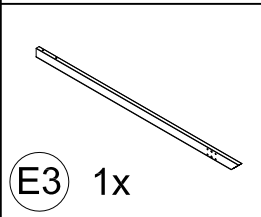
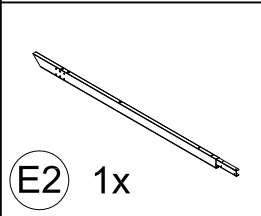
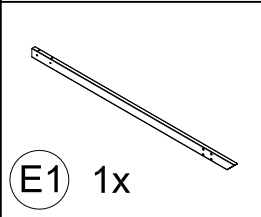
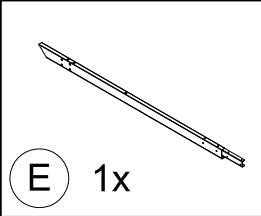

Step 11:

- ① Slide 6 Pulleys #S2 into Part #E as shown.
- ② Connect Part #E and part #E1 with 4 Bolt #1 as shown.

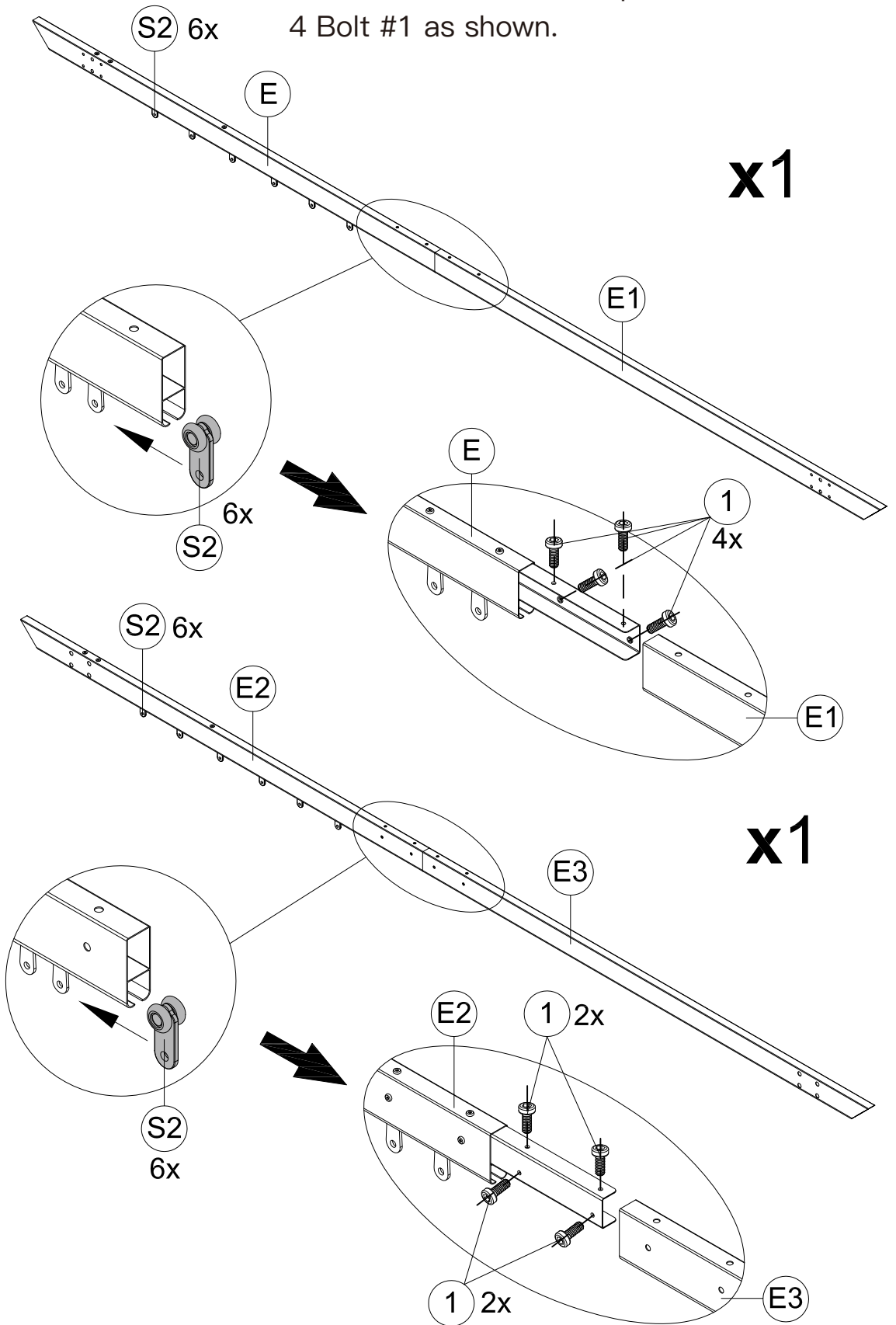

- ③ Slide 6 Pulleys #S2 into Part #E2 as shown.
- ④ Connect Part #E2 and Part #E3 with 4 Bolt #1 as shown.



T 16x

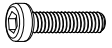

M6x20

2 16x







S4

7 1x

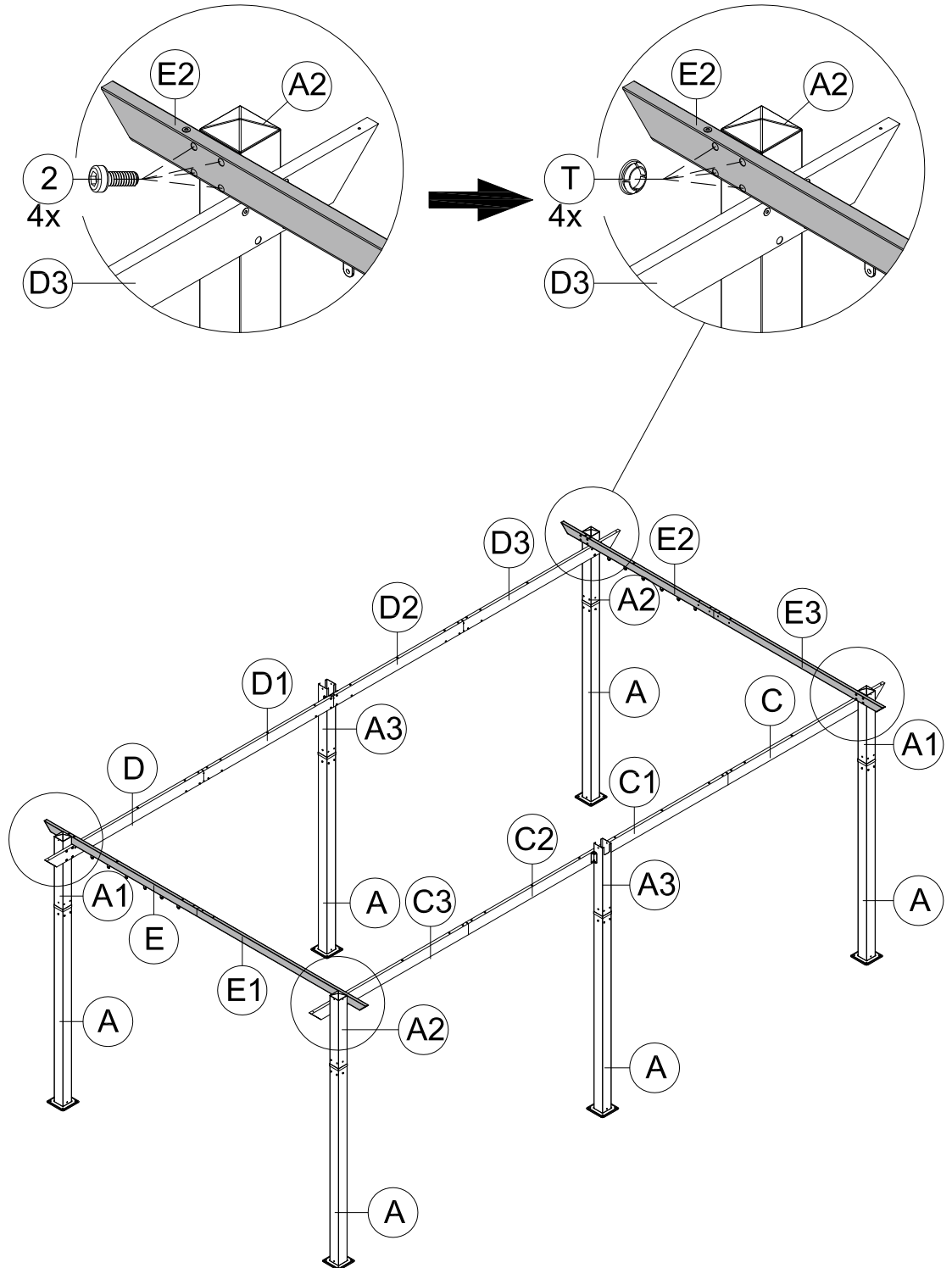
Step 12:

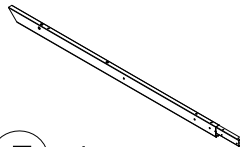
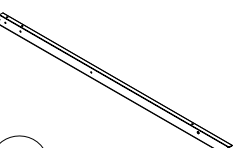
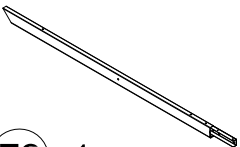
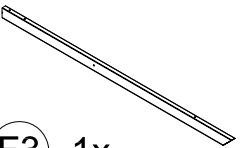
- ① Connect Part #E2(E3/ E/ E1) and Part A2(A1) with 4 Bolt #2 as shown.
- ② Put 4 plastic covers #T on the Bolt #2 as shown.



-  **F** 1x
-  **F1** 1x
-  **F2** 1x
-  **F3** 1x
-  **S2** 12x
-  **1** 8x
M6x16
-  **S4**
- 7** 1x

Step 13:

- ① Slide 6 Pulleys #S2 into Part #F as shown.
- ② Connect Part #F and part #F1 with 4 Bolt #1 as shown.

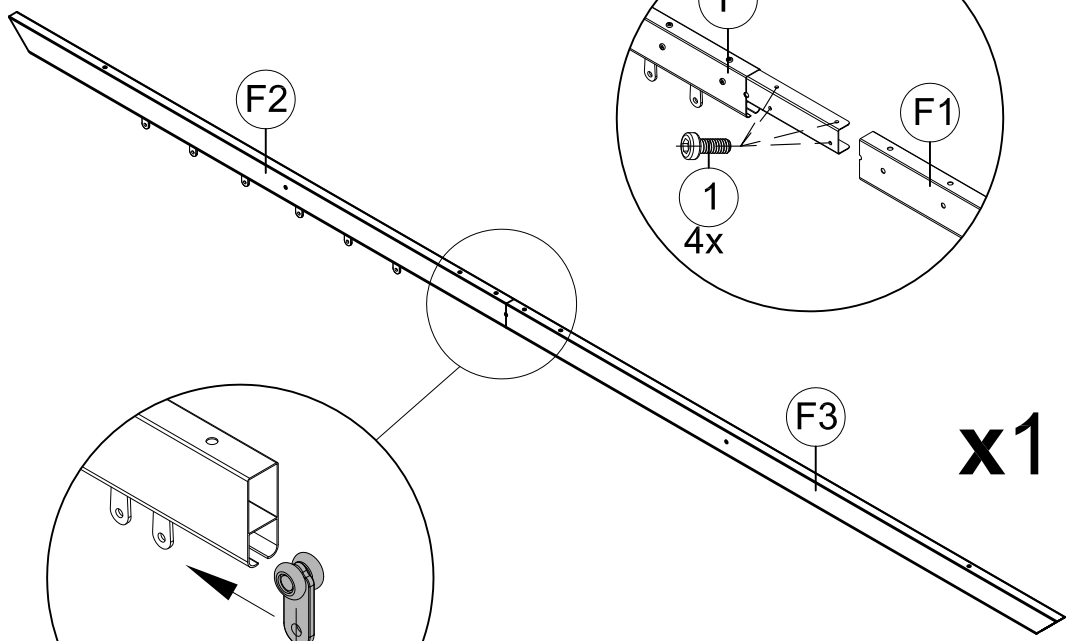
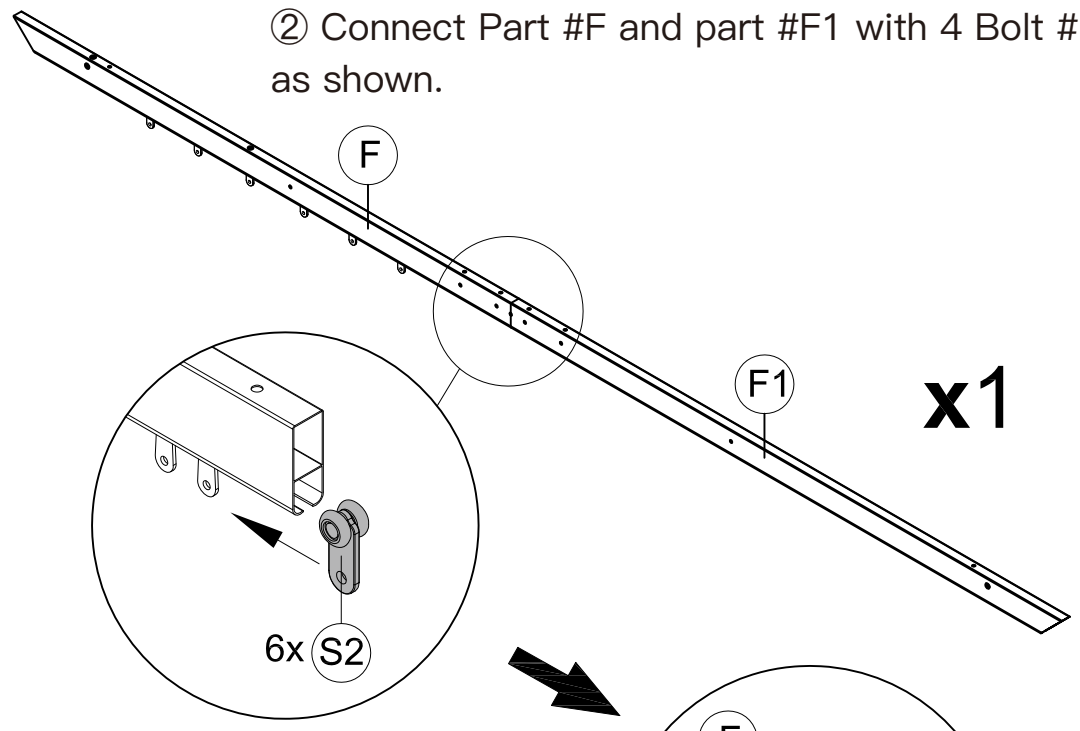

- ③ Slide 6 Pulleys #S2 into Part #F2 as shown.
- ④ Connect Part #F2 and Part #F3 with 4 Bolt #1 as shown.

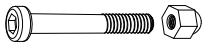

M6x65

5 3x

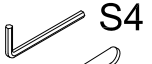

S4

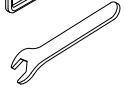

7 1x

Step 14:

① Connect the assembled crossbeam #F & F1, #F2 & F3 with 3 Bolts and Nuts #5 as shown.

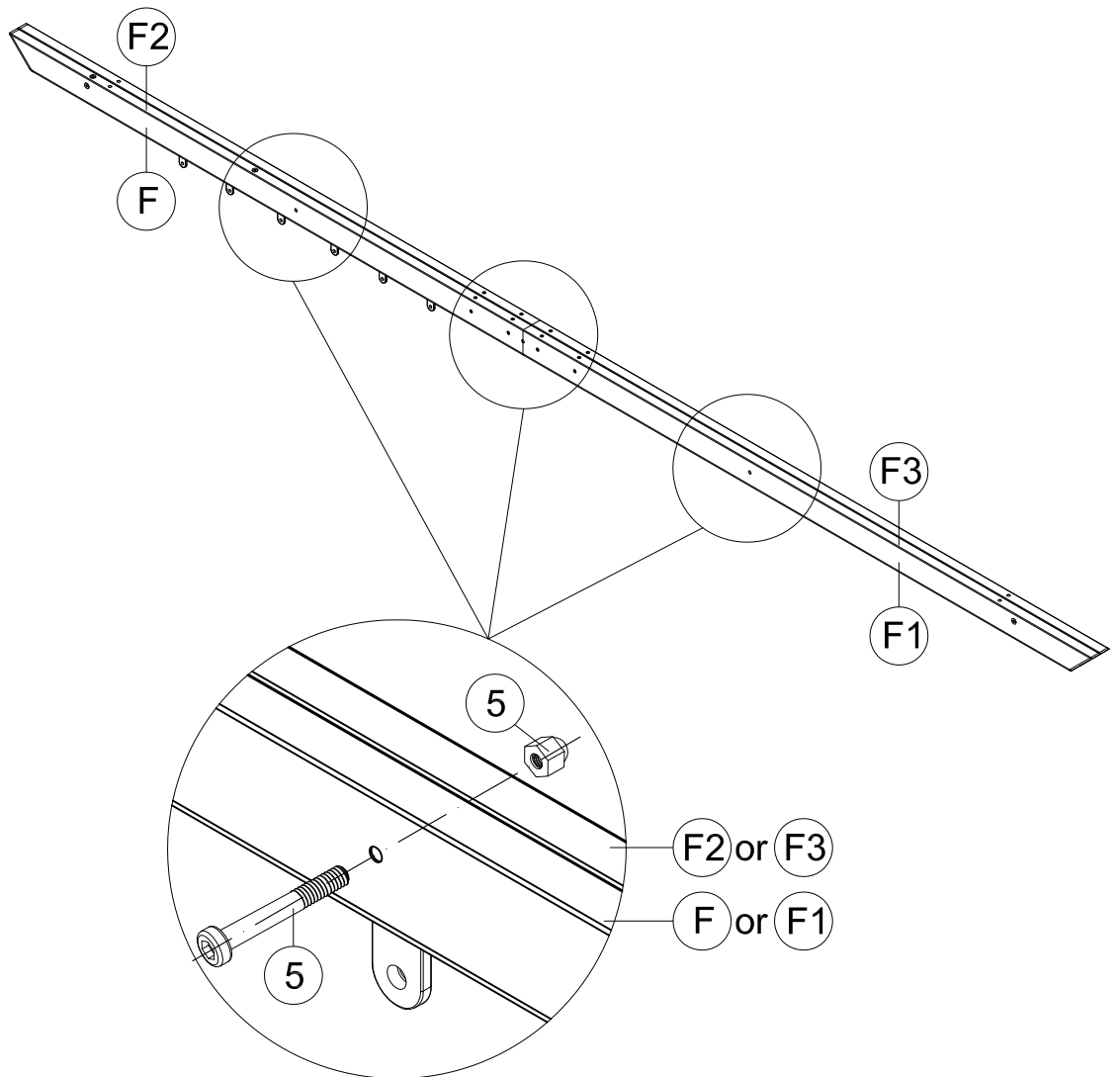

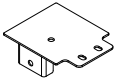

N 1x



M6x28

3 2x



7 1x

Step 15:

- ① Place Part #F & F2 on Part #A3 as shown.
- ② Put Joint Cover #N on Part #F & Part #F2 as shown.
- ③ Connect Part #F & F2 and Part #A3 with 2 Bolt #3 as shown.

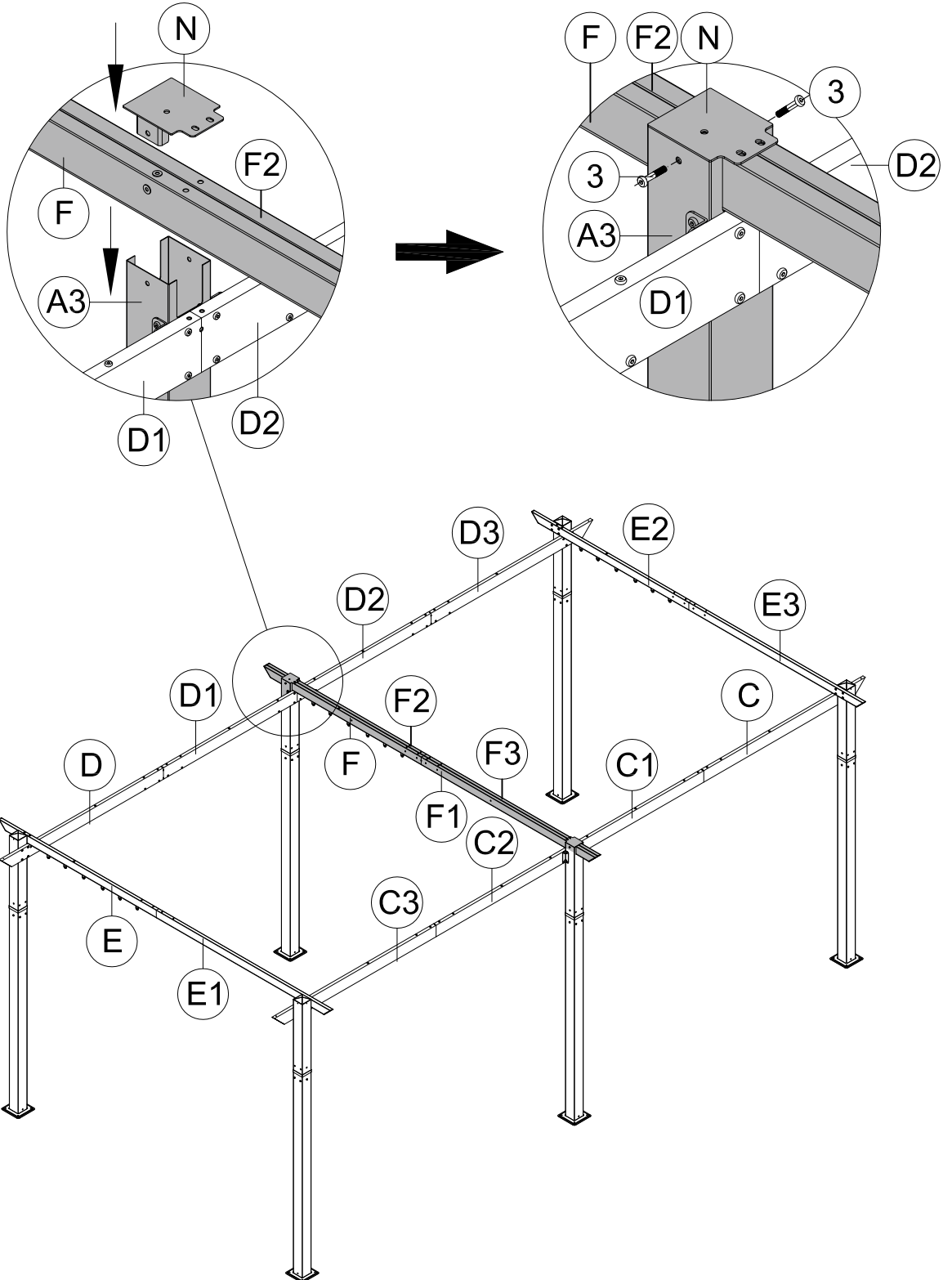

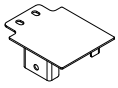

(N1) 1x



M6x28

(3) 2x

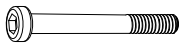

M6x85

(6) 2x



S4

(7) 1x

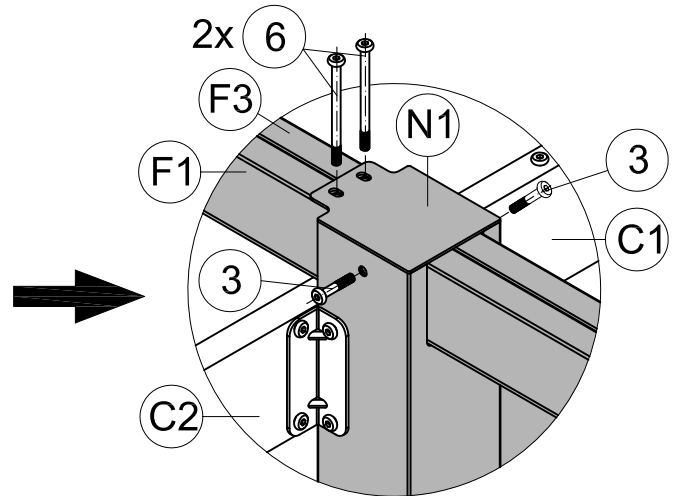
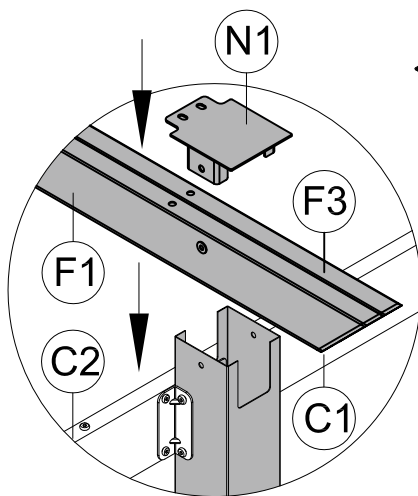
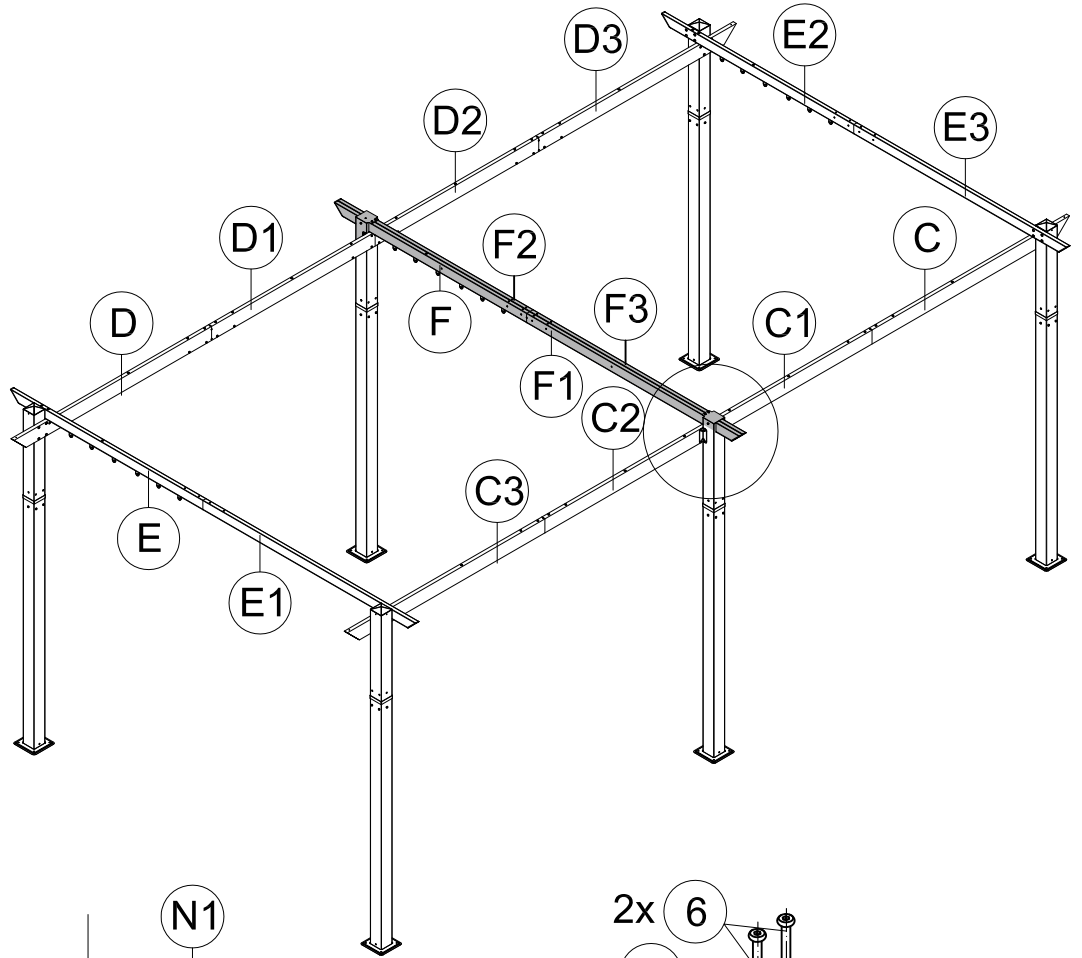

Step 16:

- ① Place Part #F1 & F3 on Part #A3 as shown.
- ② Put Joint Cover #N1 on Part #F1 & Part #F3 as shown.
- ③ Connect Part #F1 & F3 and Part #A3 with 2 Bolt #3 as shown.
- ④ Connect Part #F1 & #F3 and Part N1 with 2 Bolt #6 as shown.

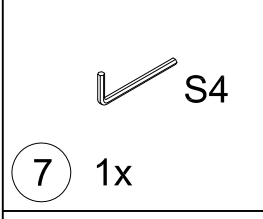
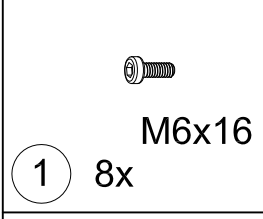
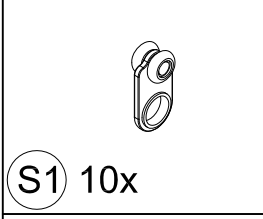
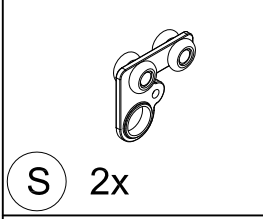
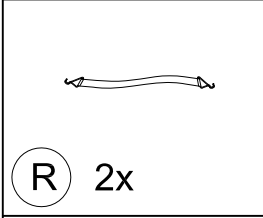
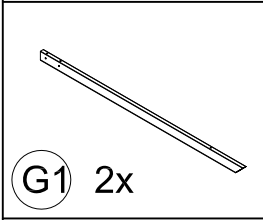
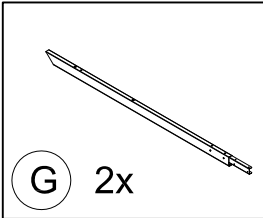

x 2

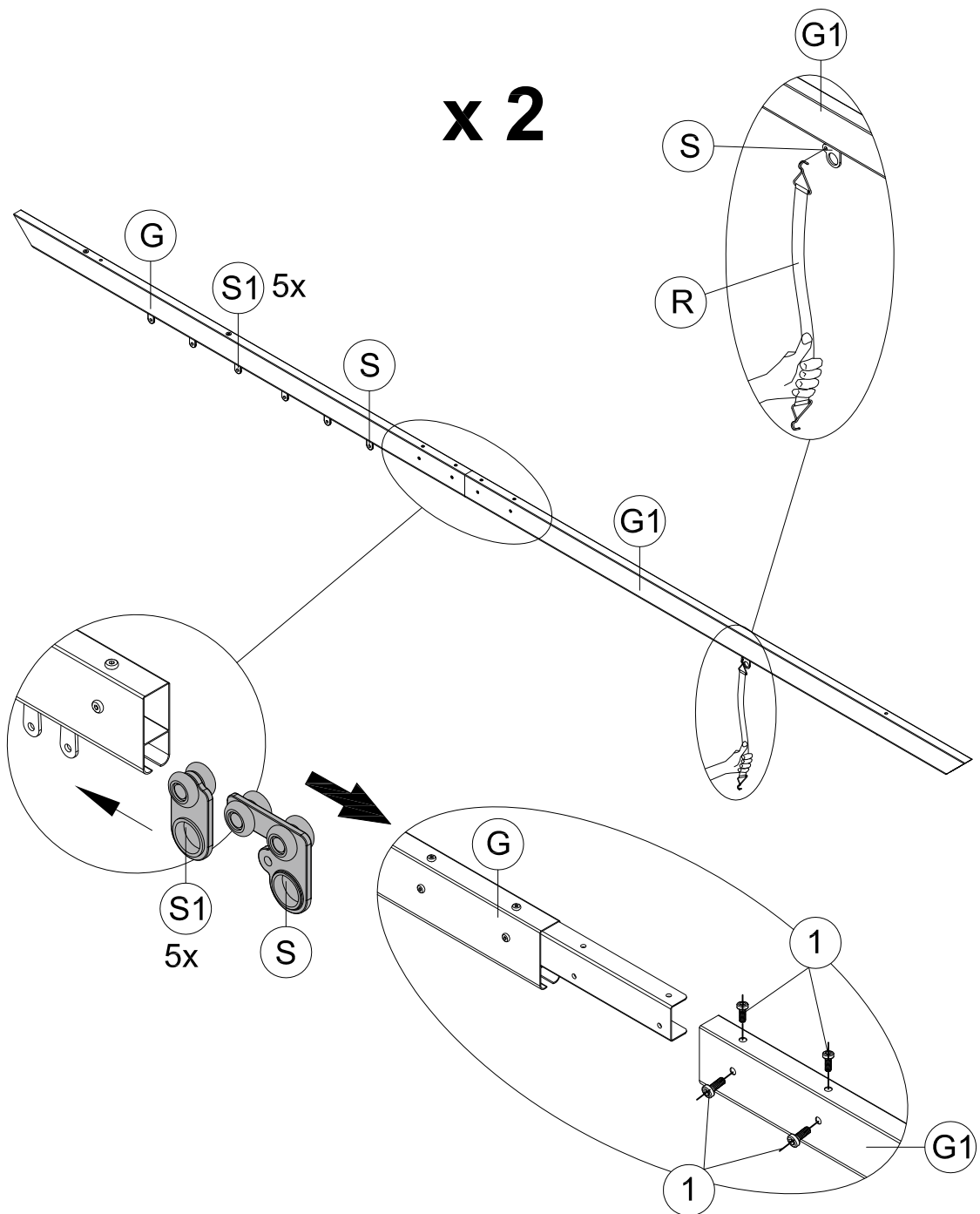

Step 17:

- ① First of all, slide 5 Pulleys #3 and 1 Pulley #S in turn into part G as shown in diagram.
- ② Connect part #G and part #G1 with 4 Bolts #1 as shown. Hang Part #R on Pulley #S.
- ③ Repeat the above procedures to assemble the second Beam #G & #G1.



M6x85

6 2x



7 1x

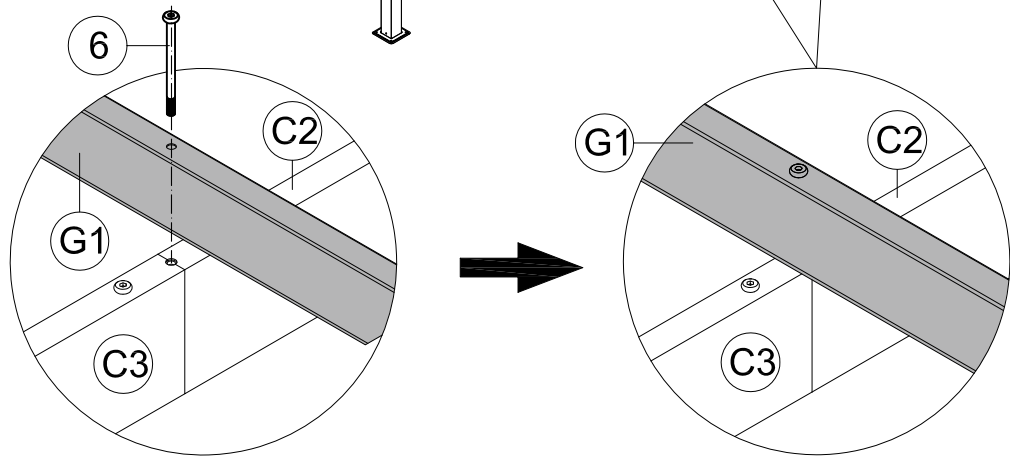
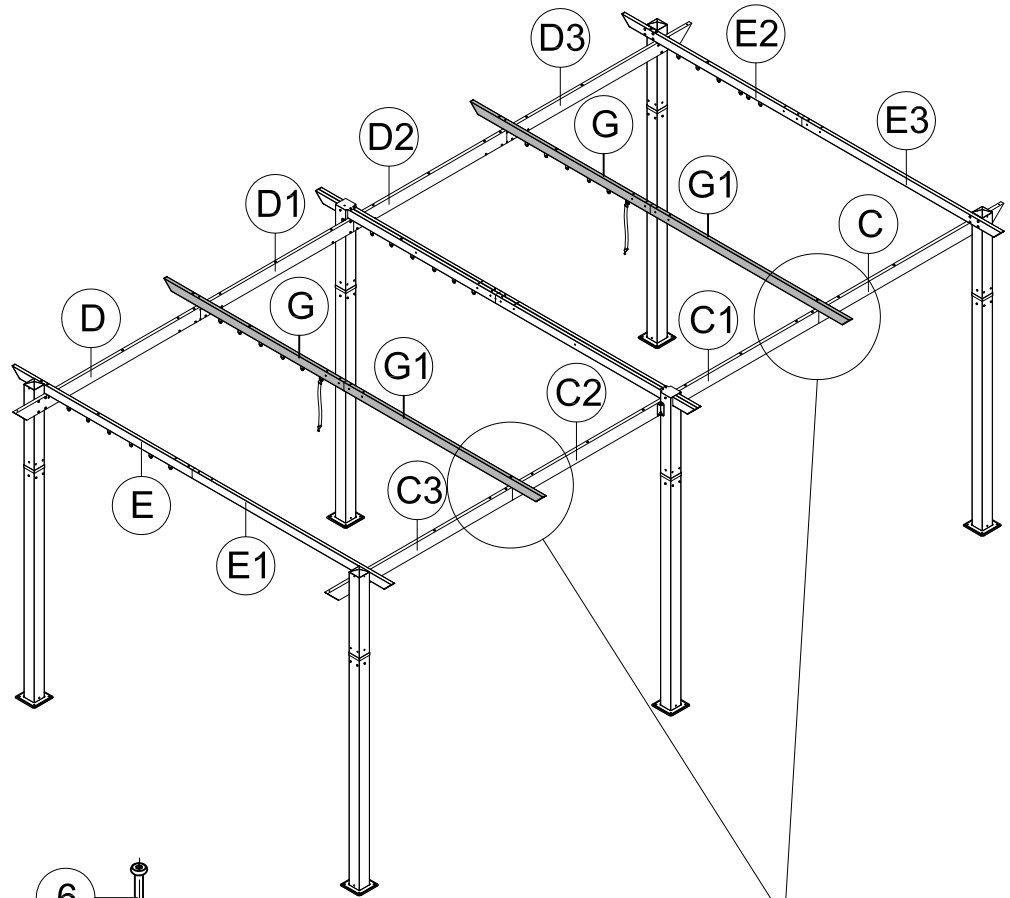

Step 18:

- ① Connect Part #G1 and Part #C2 C3 with Bolt #6 as shown.
- ② Connect Part #G1 and Part #C C1 with Bolt #6 as shown.

⚠ Don't need to assemble the opposite side in this step.

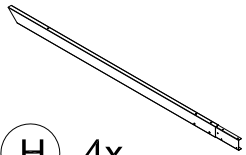

H 4x

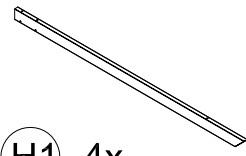

H1 4x



M6x16

1 16x



S4

7 1x

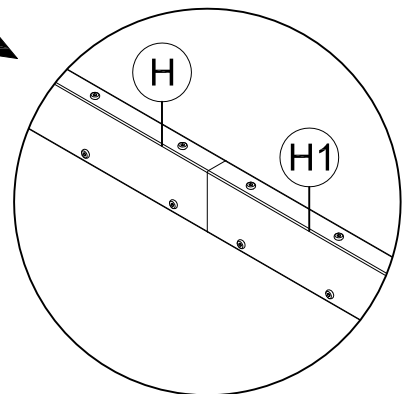
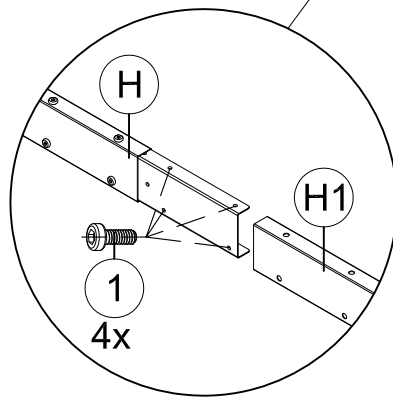
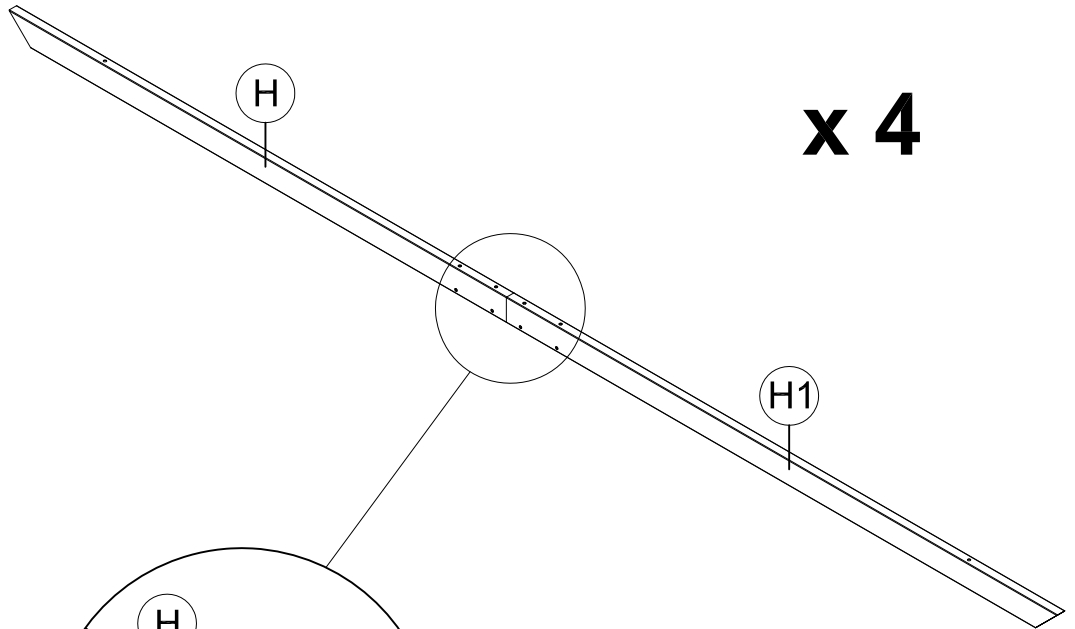

Step 19:

- ① Connect Part #H and Part #H1 with 4 Bolts 1# as shown.
- ② Repeat the above procedures to assemble the other 3 Crossbeams.

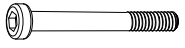

M6x85

6 8x





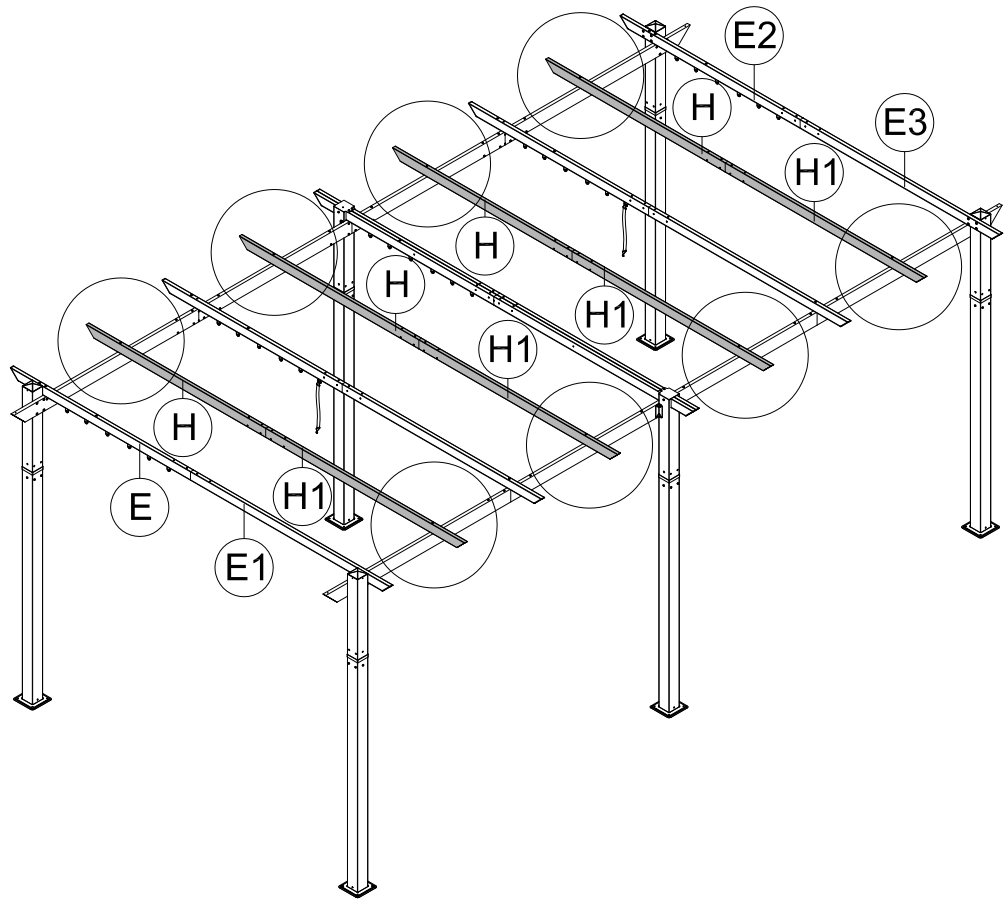
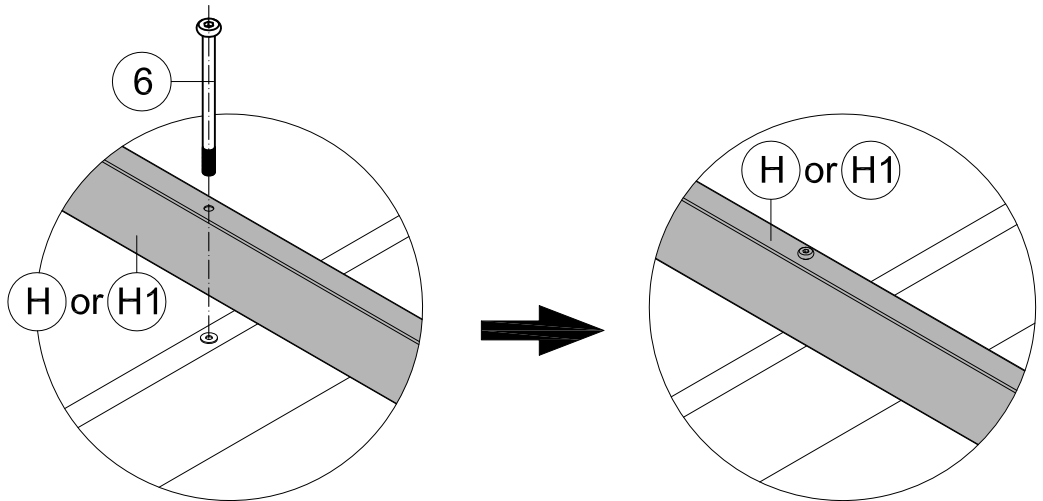

S4

7 1x

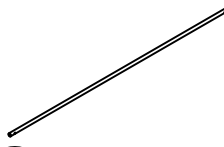
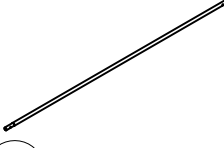
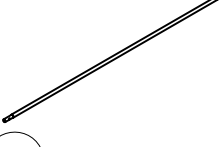

Step 20:

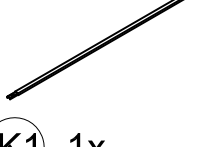
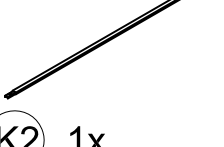
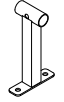
- ① Connect Part #H or Part #H1 to beam with 8 Bolts 6# as shown.

	J 2x
	J1 1x
	J2 1x
	K 2x
	K1 1x
	K2 1x
	P 5x
	U1 1x
25	

Step 21:

- ① Insert 4 sections (#K, K1, K2 ,K) into Small Canopy #U1.
- ② Insert part #J, J1, J2, J into Small Canopy #U1.
- ③ Use Canopy Support Stand #P to connect Part #J, J1, J2, J.

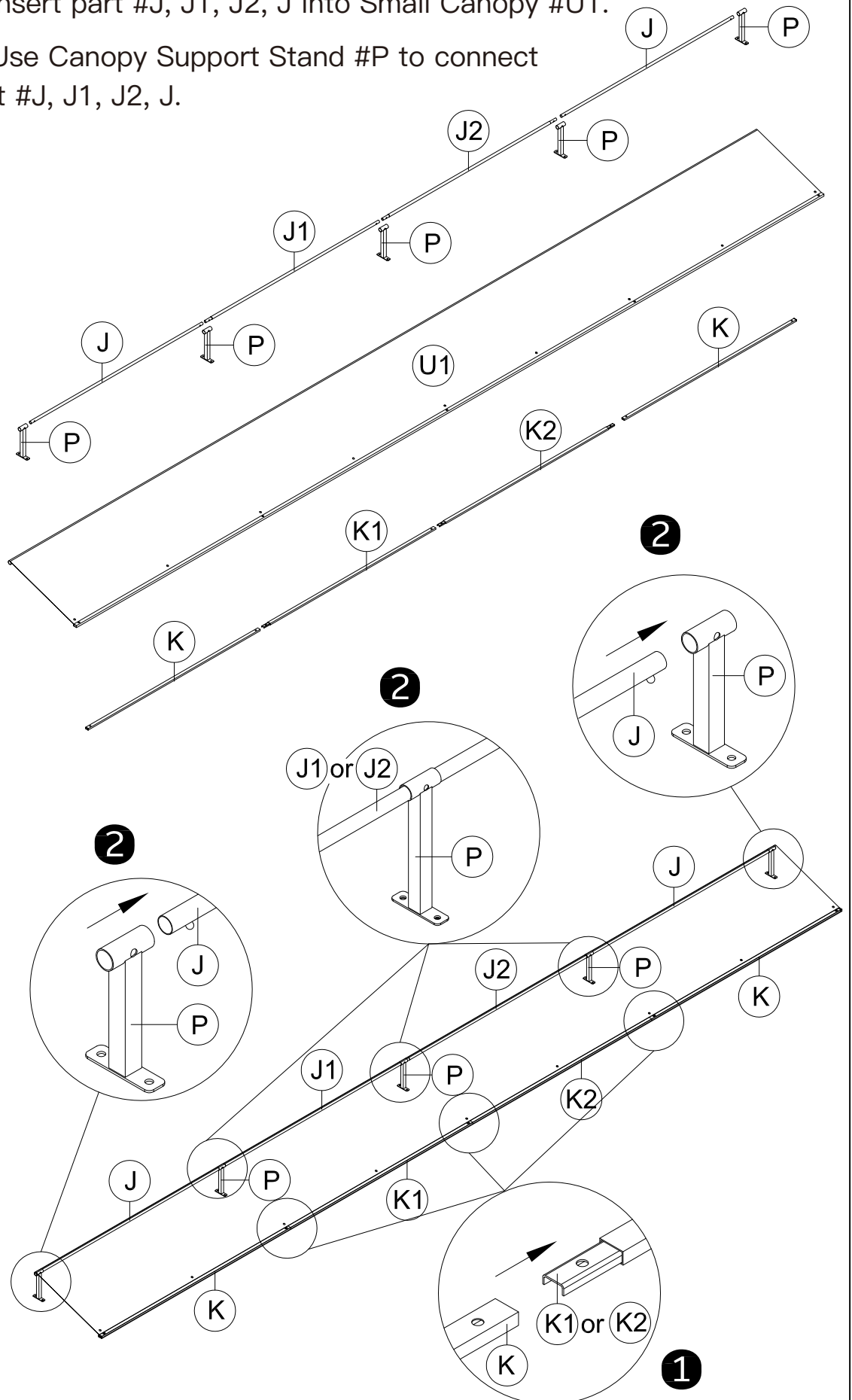



M6x16

1 7x

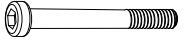

M6x85

6 4x

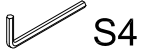

S4

7 1x

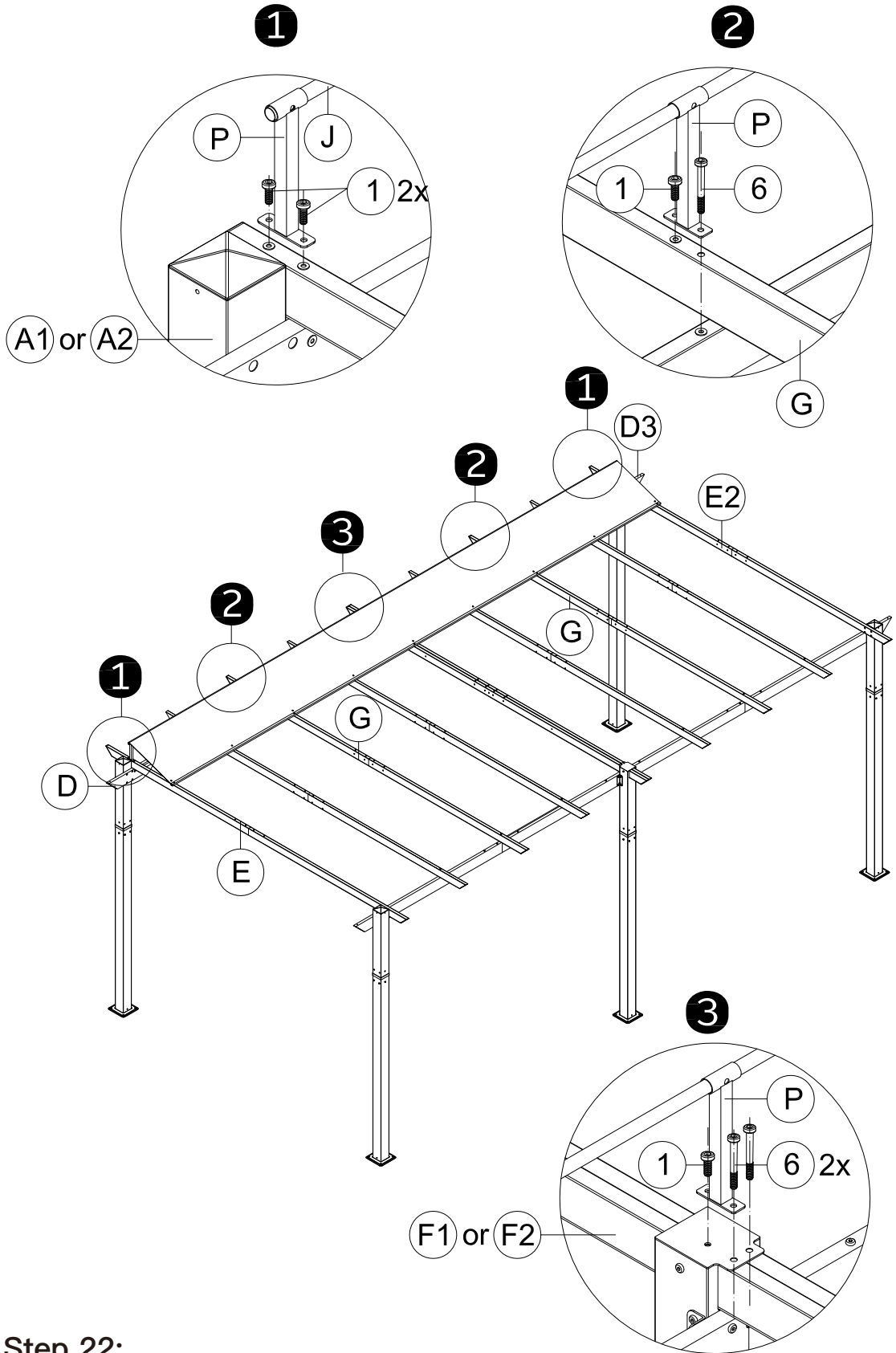

Step 22:

- ① Connect part #P and part #A1(A2) with 2 Bolt #1 as shown.
- ② Connect part #P and part #G with screw 1# and Bolts #6 as shown.
- ③ Connect part #P and part #F F2 with 1 Bolt #1 and 2 Bolts #6 as shown.



M6x28

3 5x



S4

7 1x

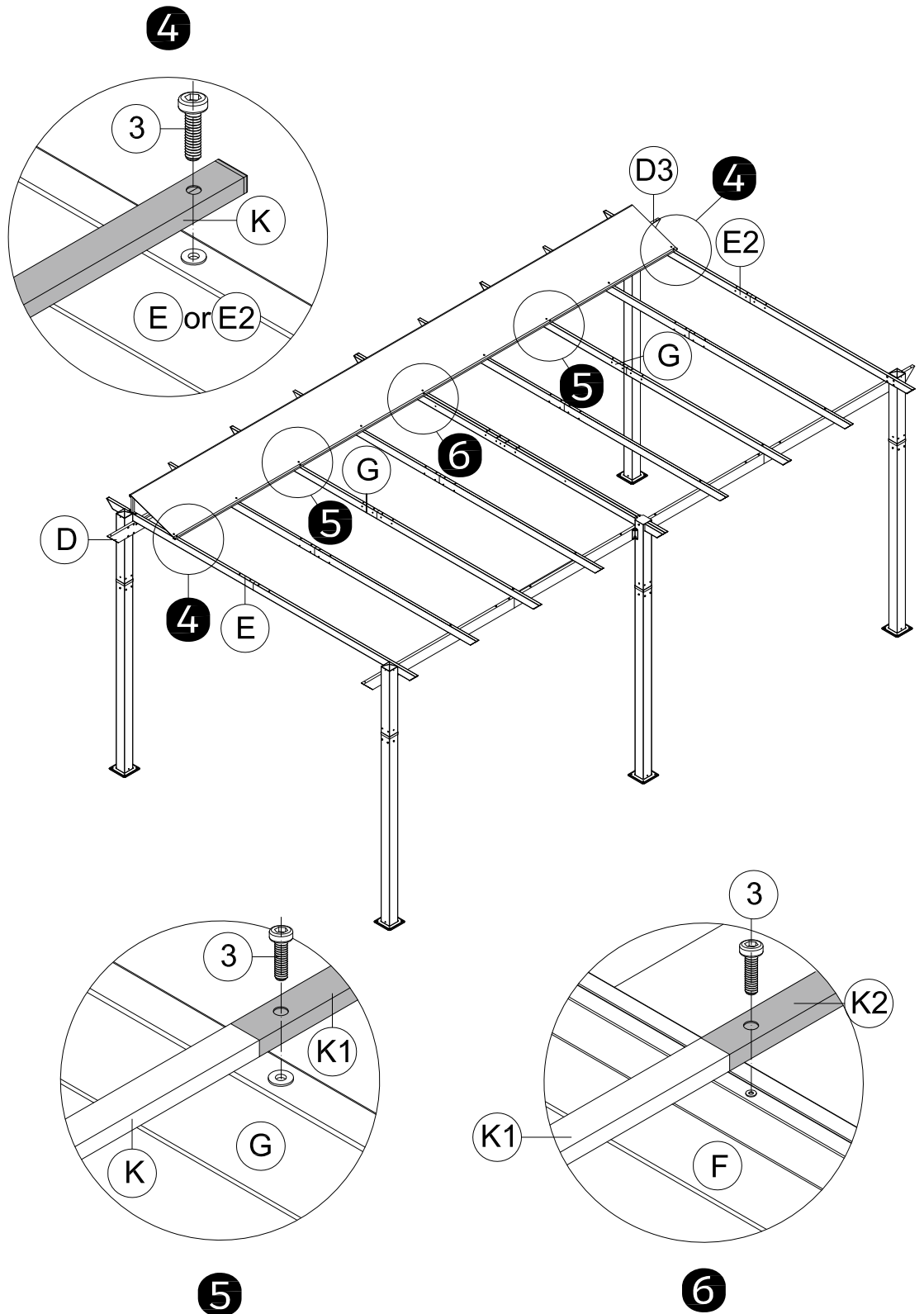

Step 23:

- ④ Use Bolts 3# to affix Part K with Cross Beam (Part #E or E2) as shown.
- ⑤ Use Bolts 3# to affix Part K1 with Cross Beam (Part #G) as shown.
- ⑥ Use Bolts 3# to affix Part K2 with Cross Beam (Part #F) as shown.

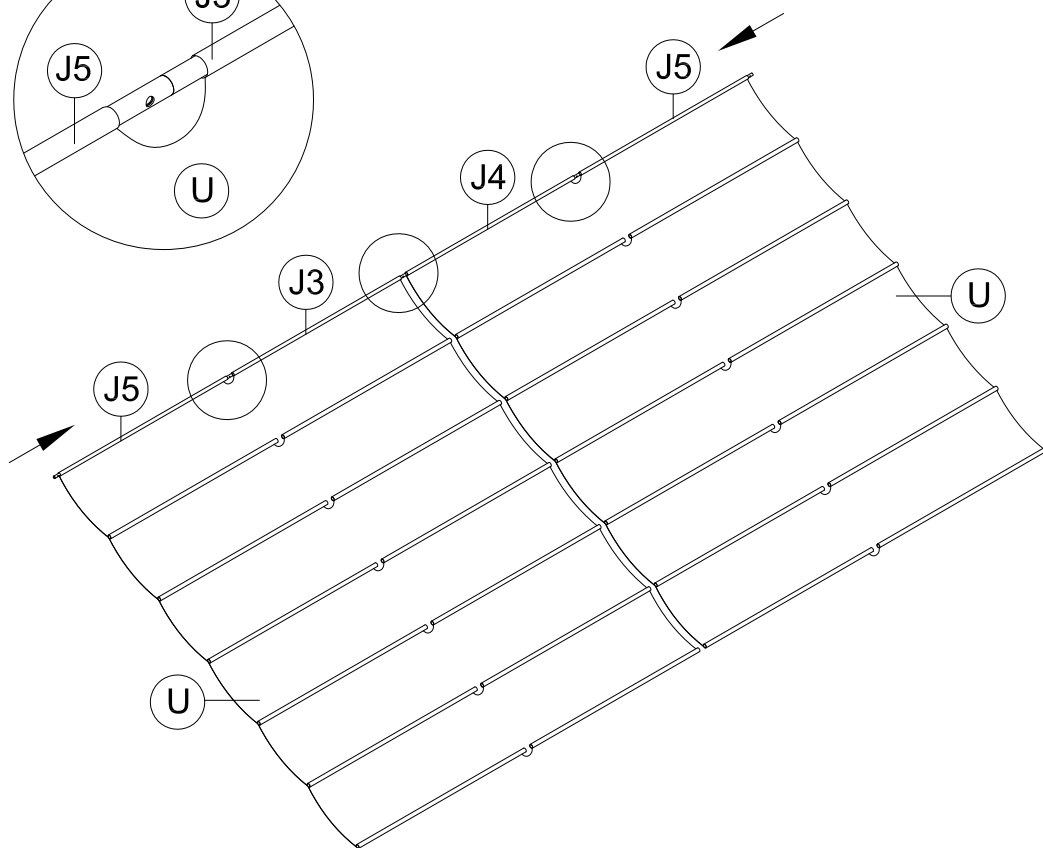
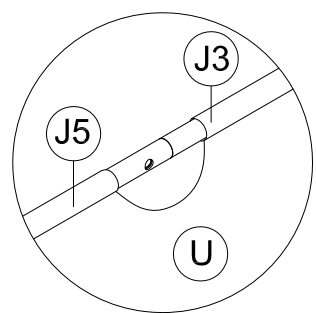
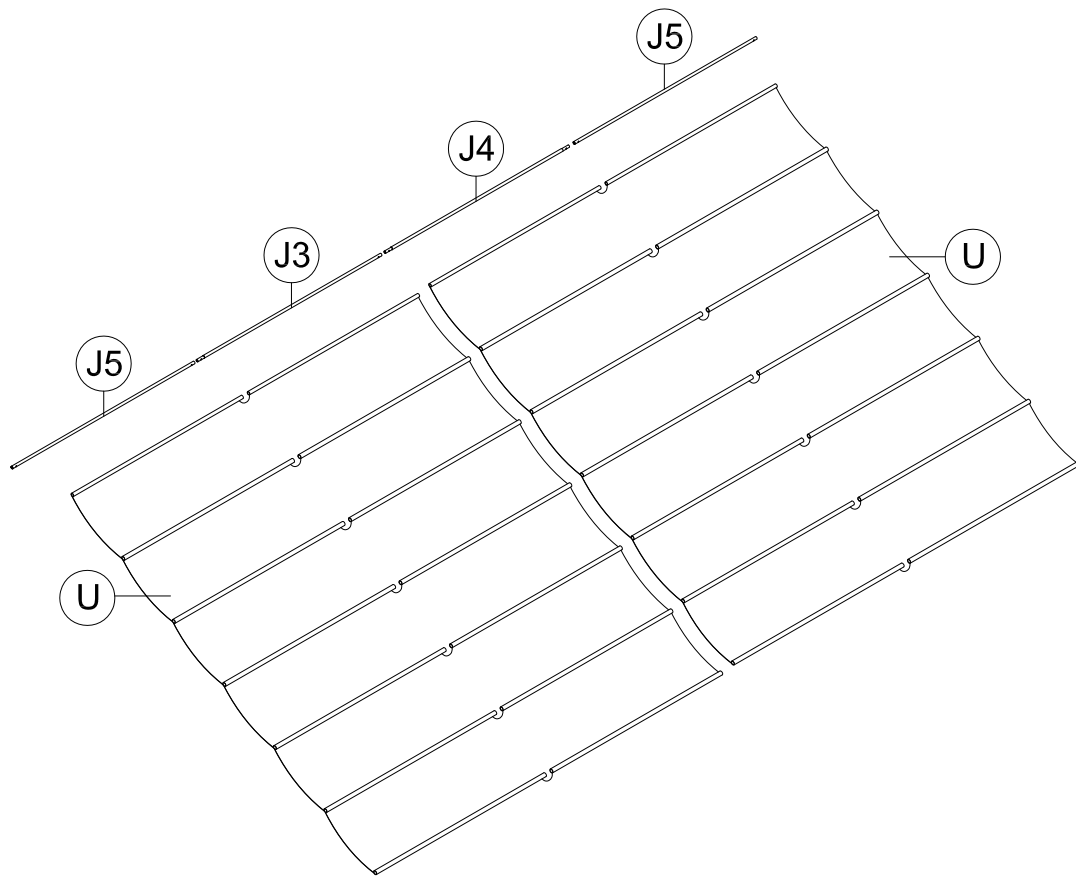
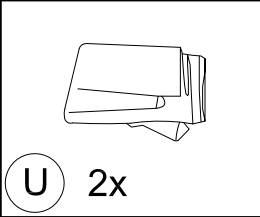
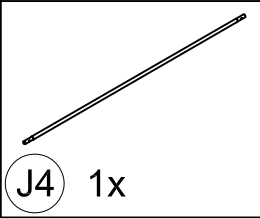
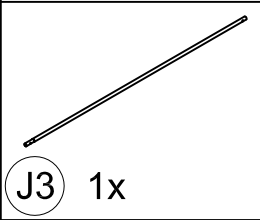
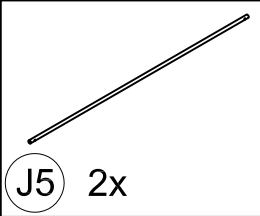

Step 24:

- ① Insert Part #J5, J3, J4, J5 into the pocket of top roof (Part U) and connect them as shown.

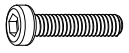

M6x28

3 5x



S4

7 1x

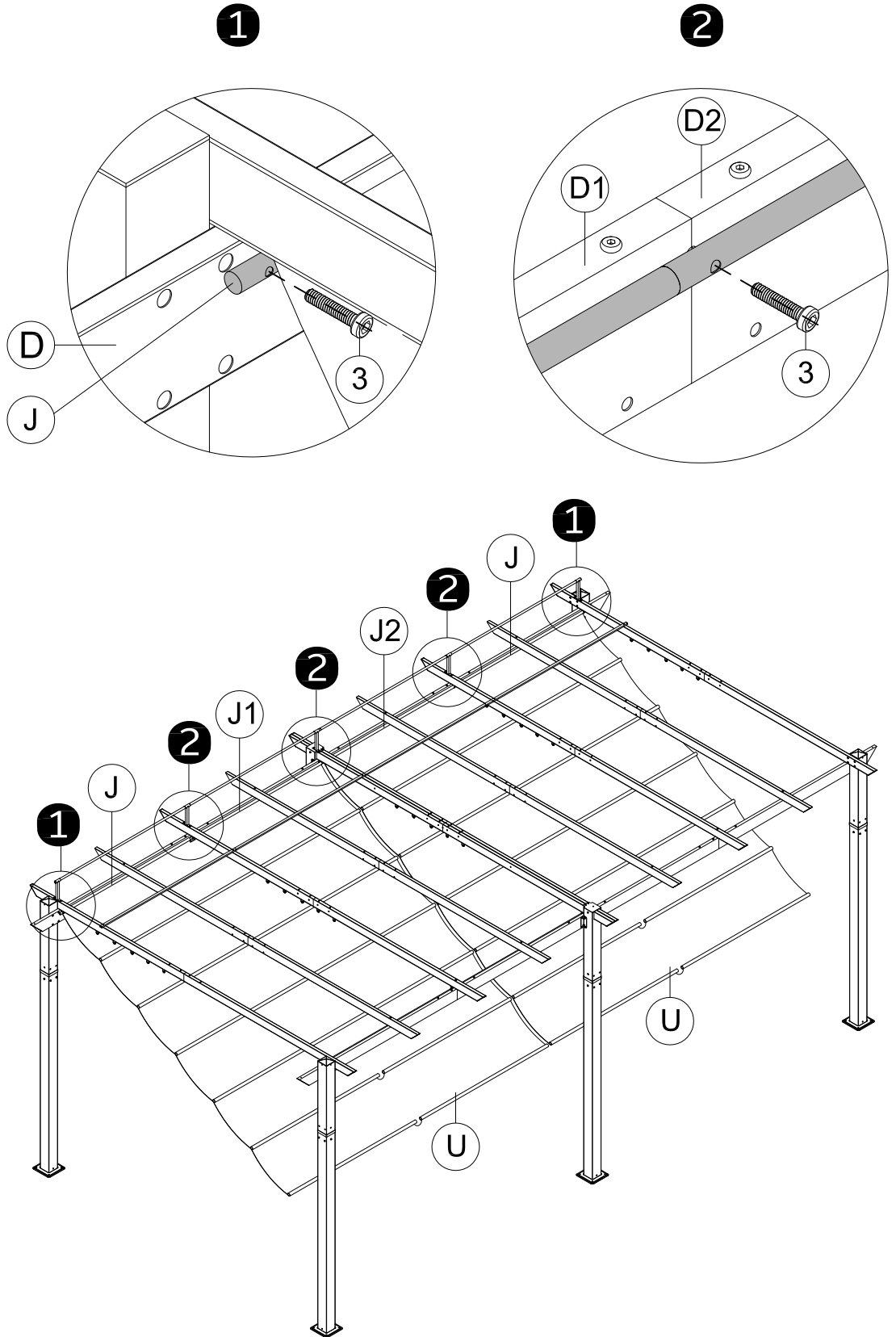

Step 25:

① Use 5 Bolts #5 to secure canopy Bar #J, J1, J2, J to the assembled Beam as shown.

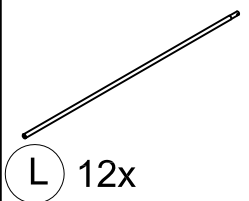

L 12x

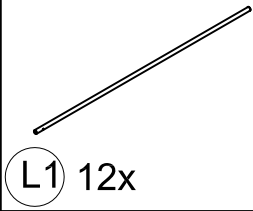

L1 12x



M6x16

1 24x



S4

7 1x

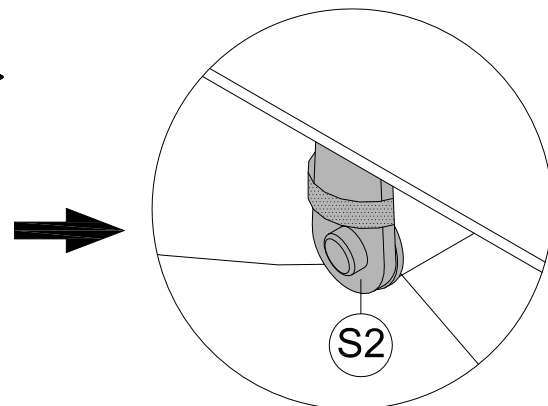
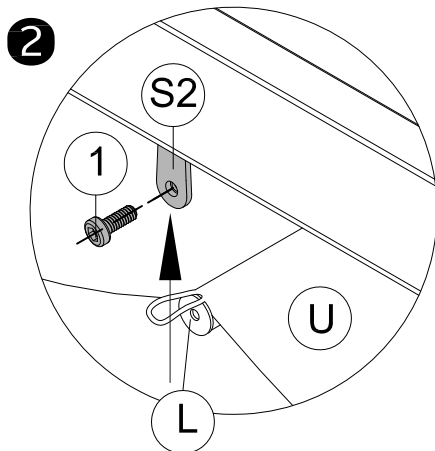
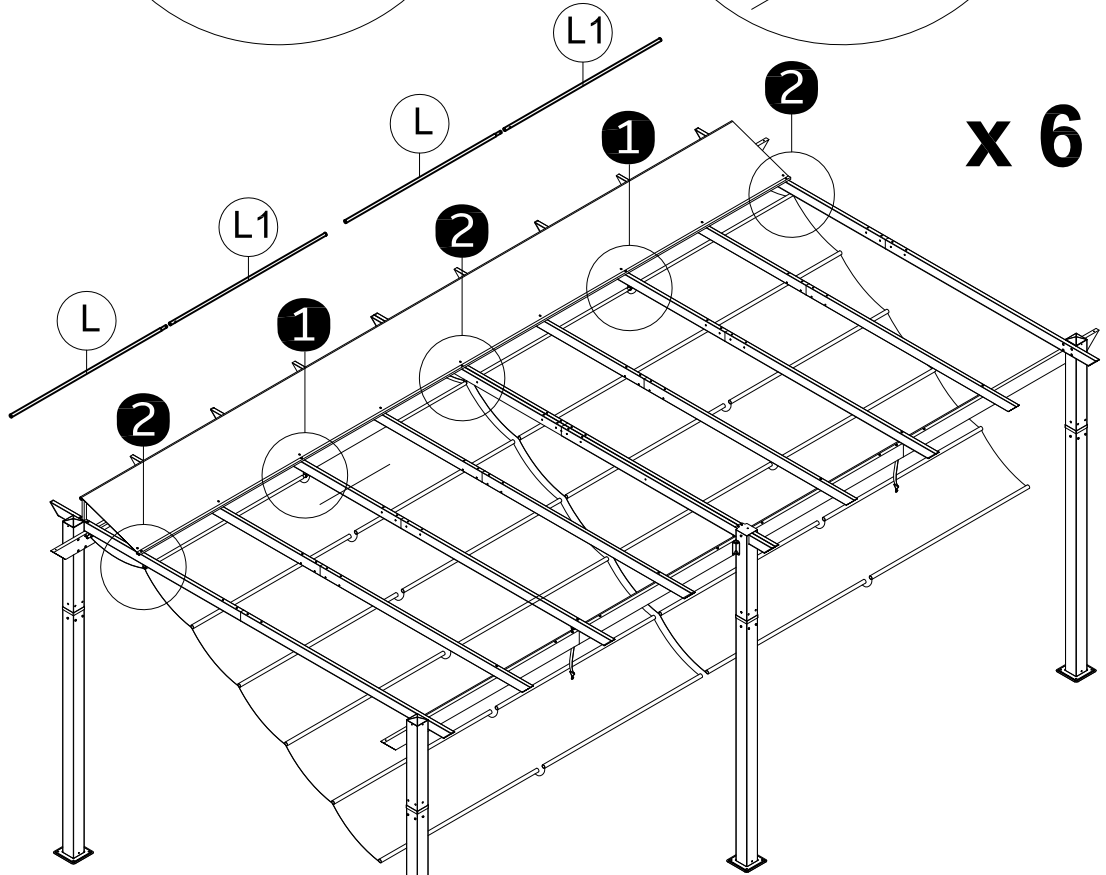
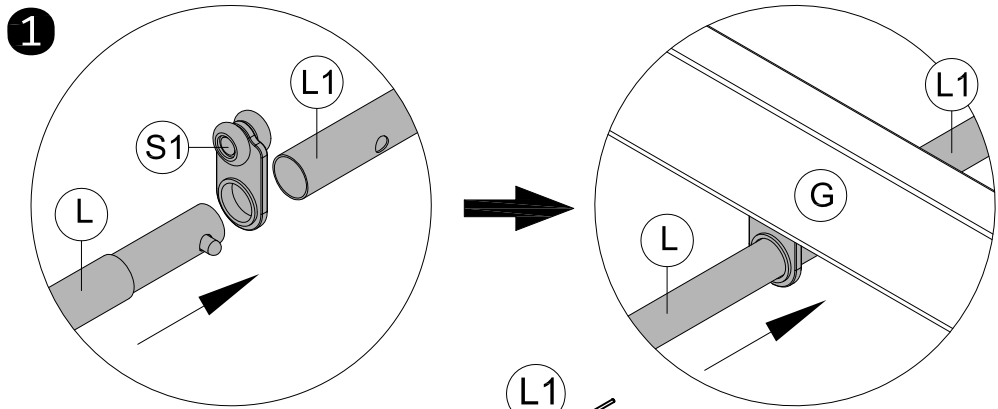

Step 26:

① Connect Part #L and L1 through the hooks (Part #S1).

② Fix Part #L and #L1 with the hooks (Part S1) on both ends using Bolt 1#, then attach the strap of top roof to the hook for securing the tube.

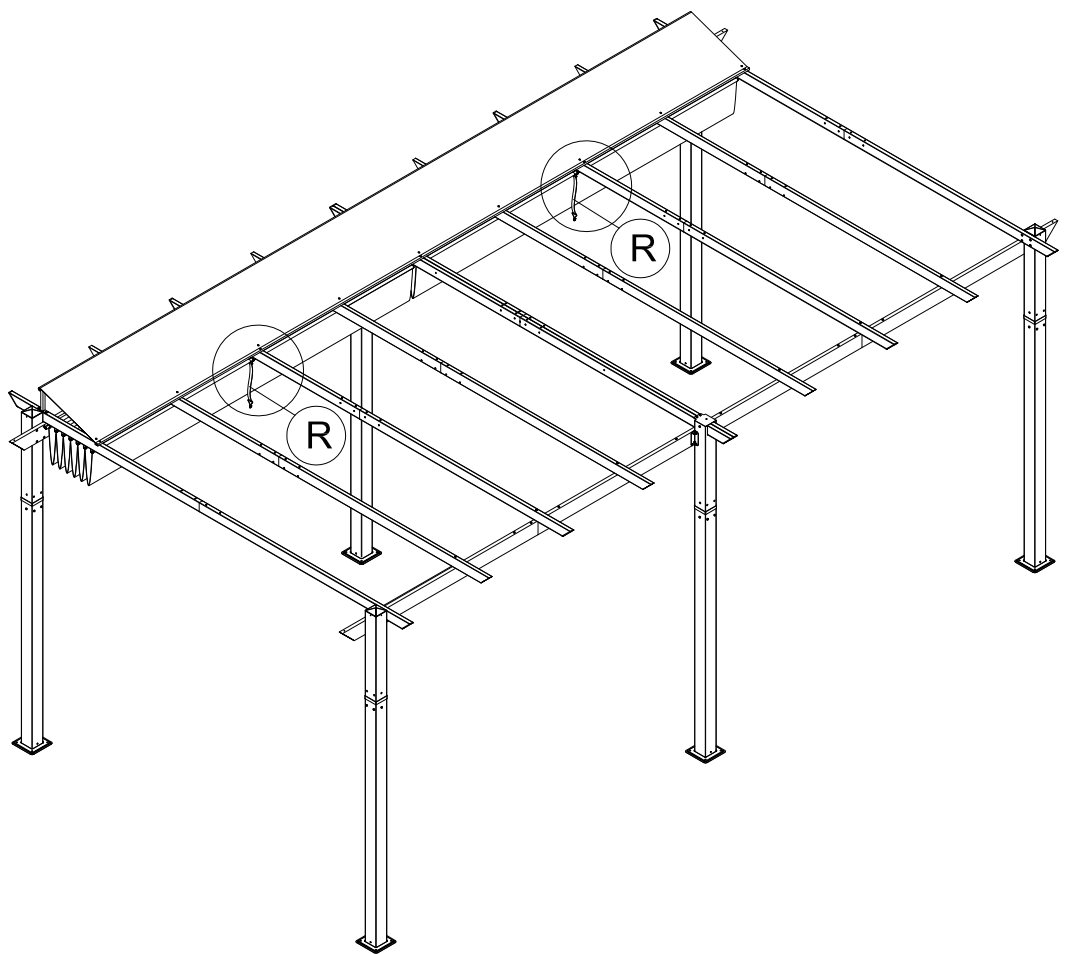
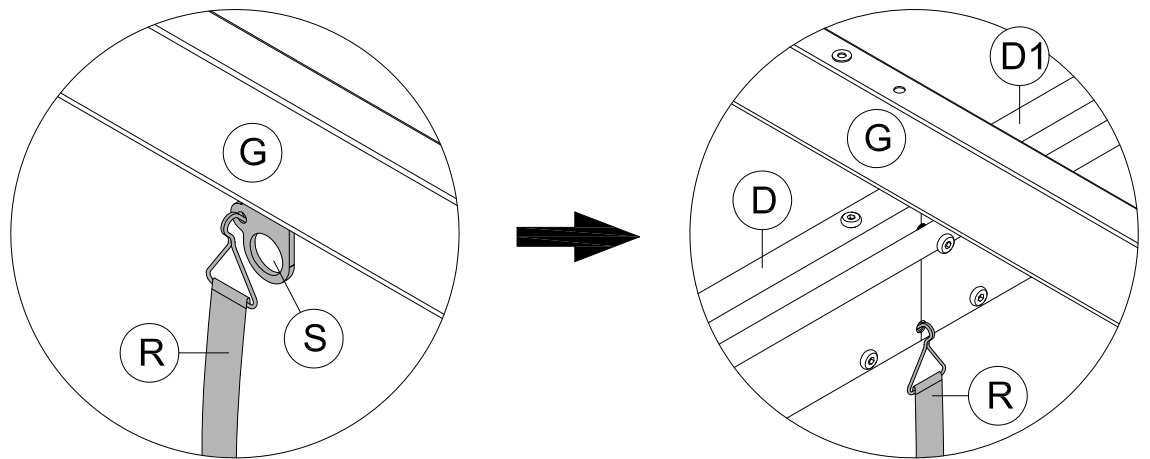

Step 27:

- ① When the canopy is folded, hang the other end of string (Part R) into the hole on the inside of Beam (Part #D and Part #D1) to secure the top roof.



V 12x

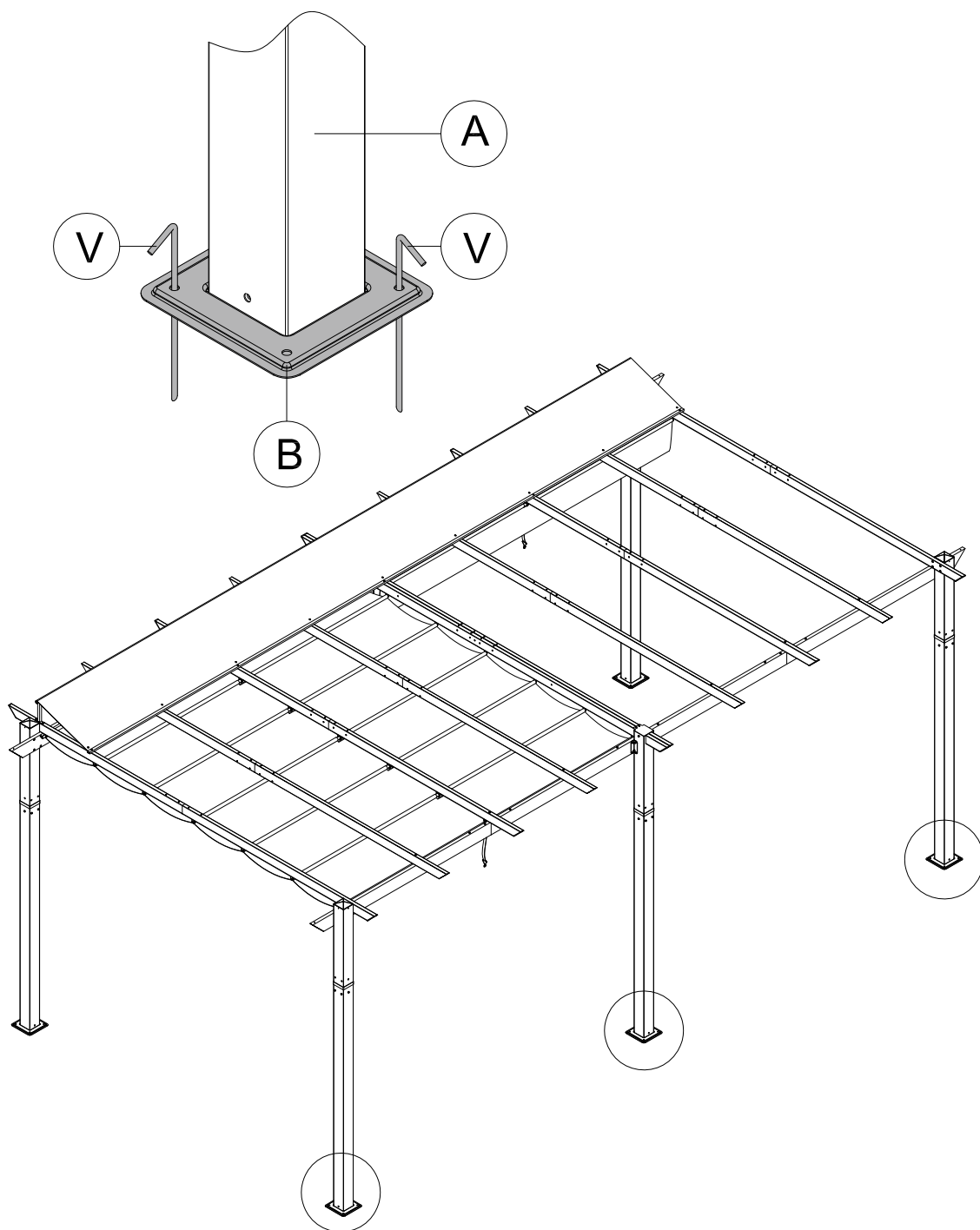

Step 28:

① Insert stakes (Part V) through the hole of stand plate (Part B) into the ground, to stabilize the tent.

⚠ Only used temporary, they can not stand against the heavy wind.



Thanks for your purchase.

At domi outdoor living, we believe in our products.

That's why we provide a 12-month warranty and

friendly, easy-to-reach after-sales service. So if you

have any questions about our product and assembly-

,please feel free to contact us. We will be here for you.

Support:  

After-sales contact email:

service@domioutdoorliving.com

Business cooperation contact email:

marketing@domioutdoorliving.com

Please tell us your order ID when contact.

Attach photos of damaged part for instant reply.