

12'x16' Metal Patio Wood Gazebo

ASSEMBLY MANUAL

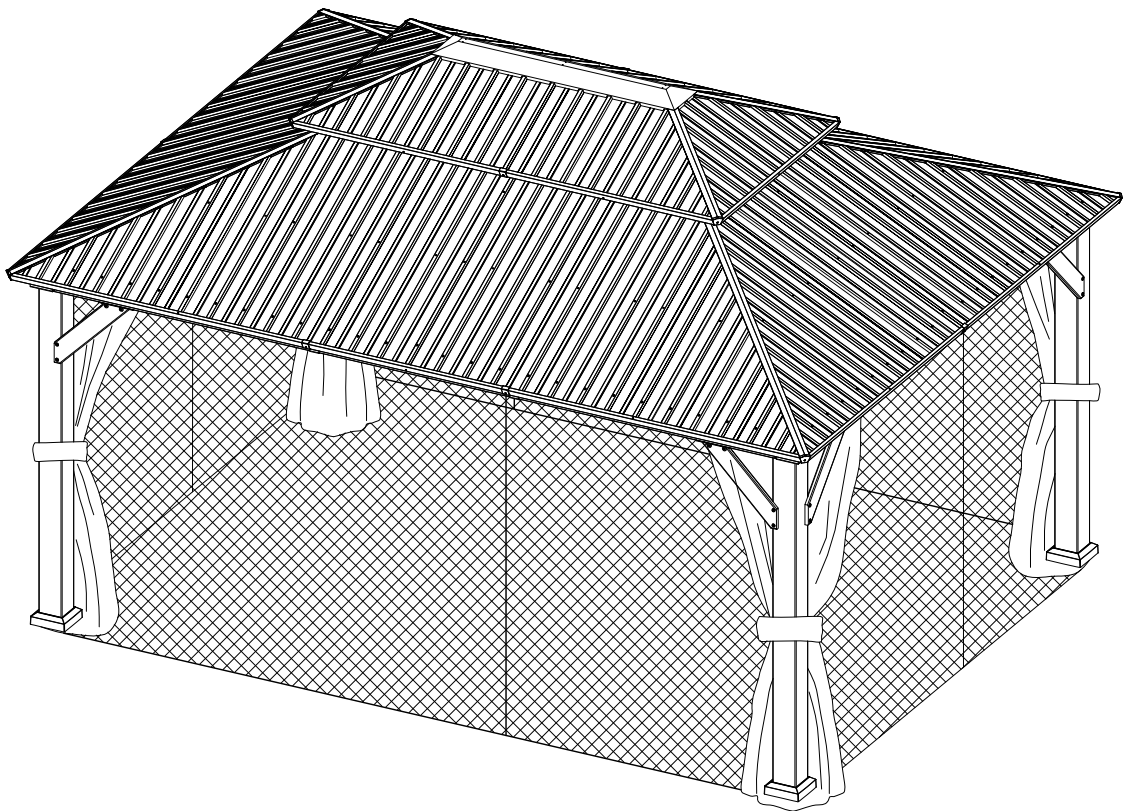

MODEL#:LGMF1638

Missing part? Damaged? Contact us via email at

service@domioutdoorliving.com

www.domioutdoorliving.com

Pre-assembly



1. Two or more people are required for assembly.



2. You will need one or more stepladders.



3. Wearing protective gloves is recommended.



4. You may need a safety hat.

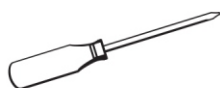

5. Please use a Phillips screw driver.



6. For ease of construction, you may need a drill.



7. You may need a safety goggle.



8. Do not fully tighten screws prior to complete assembly.

Warning & Attention

-Try to assemble this product on the flat ground, otherwise it is difficult to carry out;

-It would be much easier to assemble the product with three or more people;

-After assembly, please check whether all screws are tightened, to prevent parts from falling apart.

▲ Use bolts to secure the frame to the ground to against the strong wind.

1

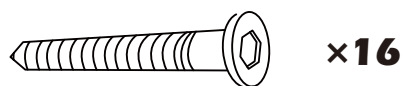
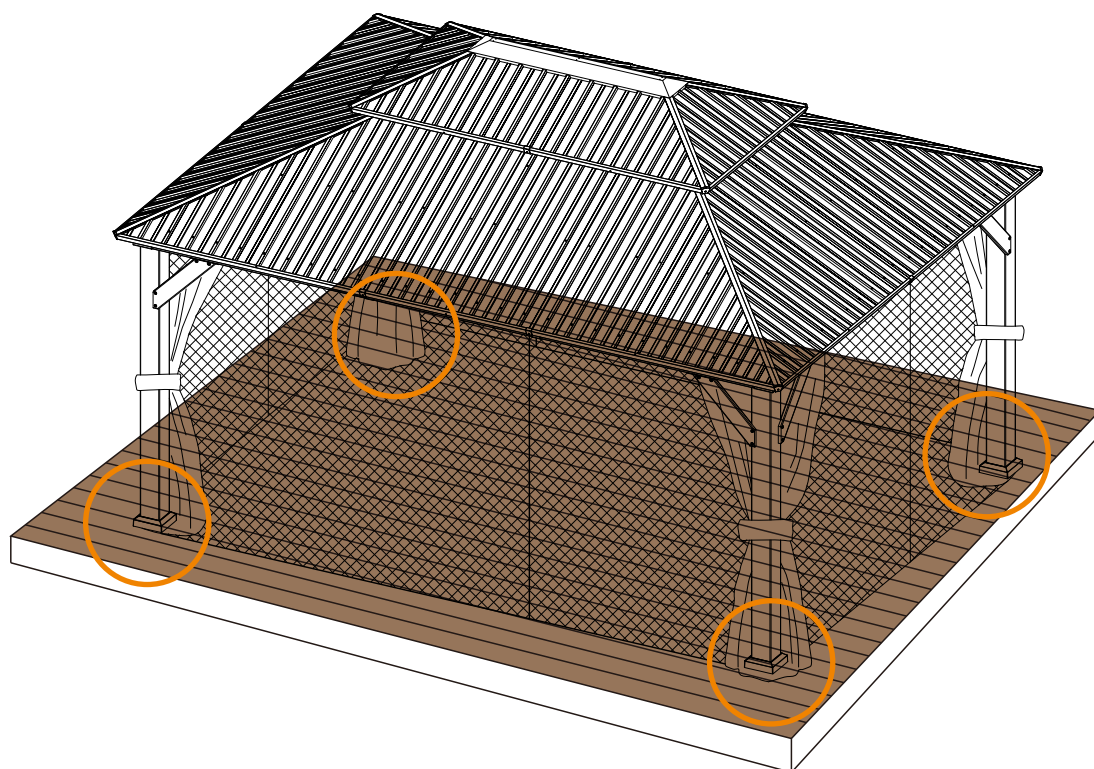

If the deck is hard wood and the depth of it is over 3 inch, you can use **5/16 in. x4 in. Structural Wood Screw** to mount the gazebo.

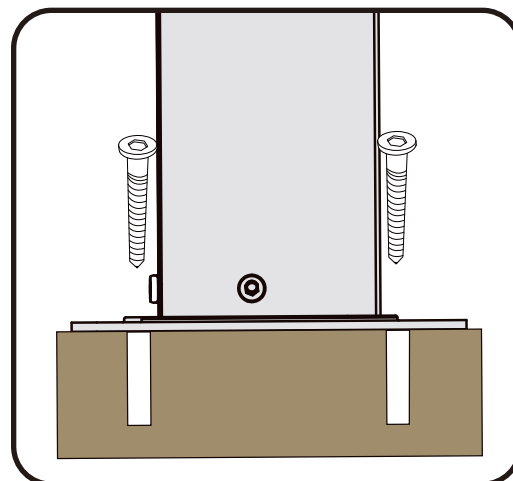
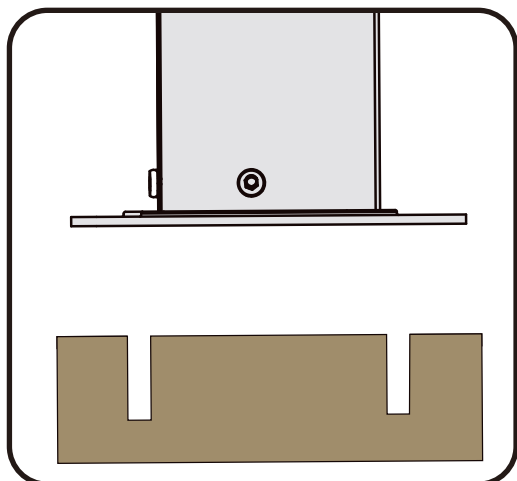

2

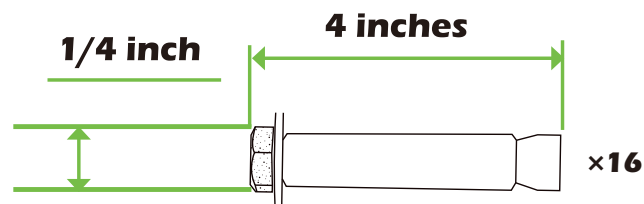
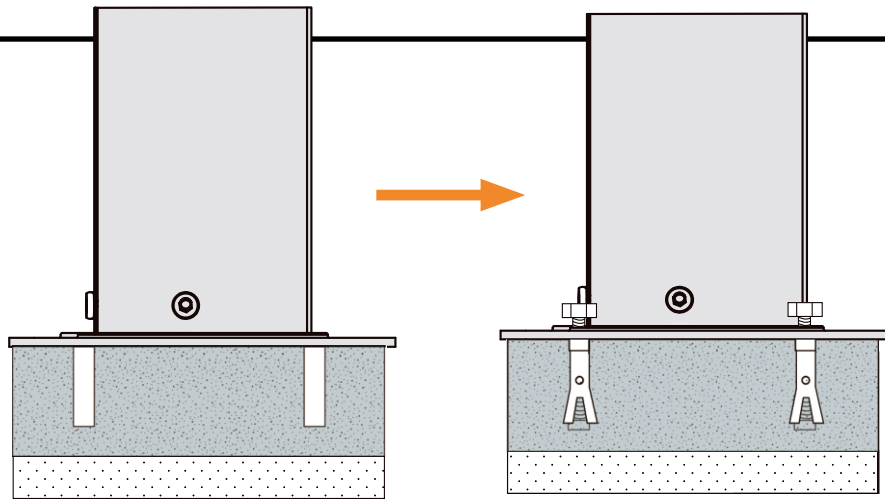

If the ground is concreted and the depth of it is over 3 inch, you can use 1/4 inch expansion bolts to mount the gazebo

3

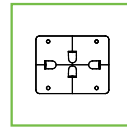
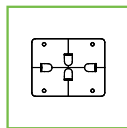
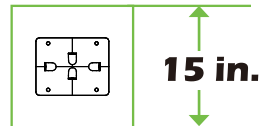
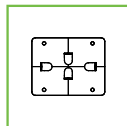

Or you can make a concrete footing for gazebo, **15×15×15 inches** is recommended. use expansion bolts to mount the pergola like ② shows.

IMPORTANT:
Anchor is not recommended

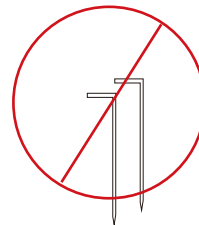

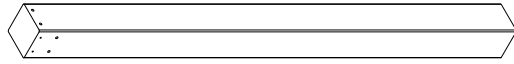

A 4x Wood Post



C 2x Beam



C1 2x Beam



D 2x Beam



D1 2x Beam



D2 2x Beam



E 4x Corner Roof Bar



E1 4x Corner Roof Bar Connector

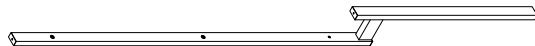

E2 8x Middle Roof Bar

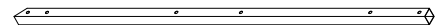

F 4x Solidifying Bar

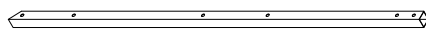

G 4x Solidifying Bar

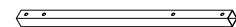

G1 4x Solidifying Bar

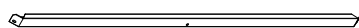

H 2x Finishing Bar



H1 2x Finishing Bar

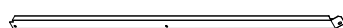

H2 2x Finishing Bar

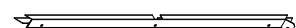

J 2x Finishing Bar

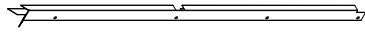

J1 2x Finishing Bar

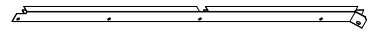

J2 2x Finishing Bar

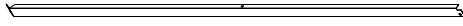

K 2x Finishing Bar

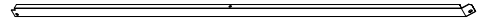

K1 2x Finishing Bar



K2 2x Finishing Bar



K3 2x Finishing Bar

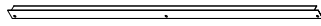

K4 2x Finishing Bar

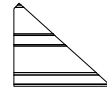

L1 2x Roof Panel

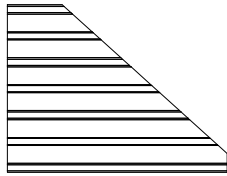

L2 2x Roof Panel

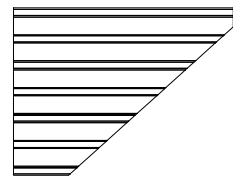

L3 2x Roof Panel

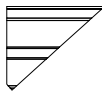

L4 2x Roof Panel

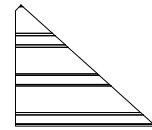

M1 2x Roof Panel

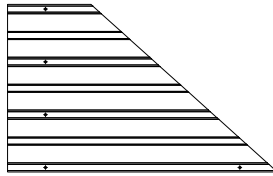

M2 2x Roof Panel

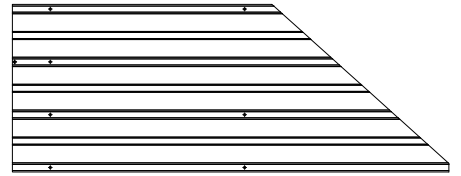

M3 2x Roof Panel

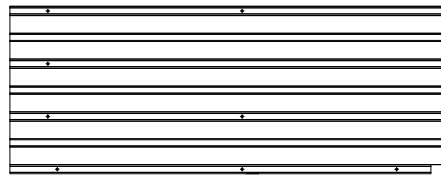

M4 2x Roof Panel

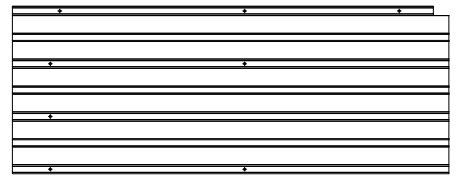

M5 2x Roof Panel

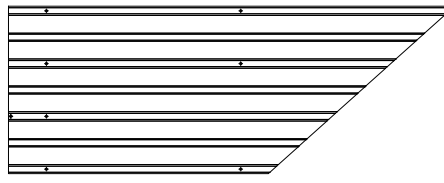

(M6) 2x Roof Panel

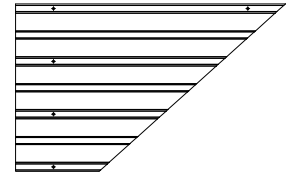

(M7) 2x Roof Panel



(M8) 2x Roof Panel

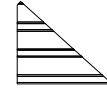

(N1) 2x Roof Panel

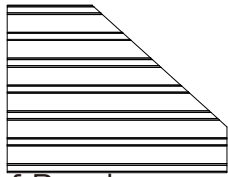

(N2) 2x Roof Panel

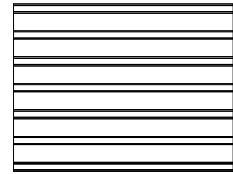

(N3) 4x Roof Panel

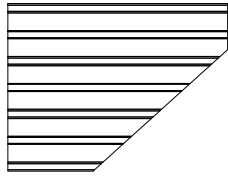

(N4) 2x Roof Panel

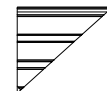

(N5) 2x Roof Panel

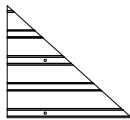

(P1) 2x Roof Panel

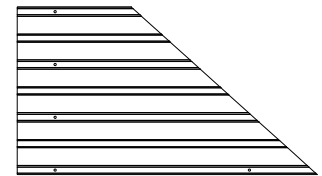

(P2) 2x Roof Panel

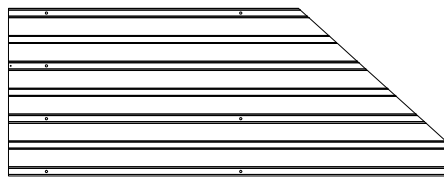

(P3) 2x Roof Panel

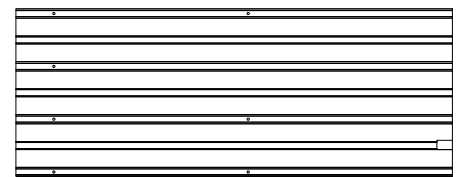

(P4) 2x Roof Panel



(P5) 2x Roof Panel



(P6) 2x Roof Panel

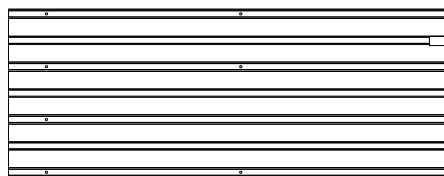

(P7) 2x Roof Panel

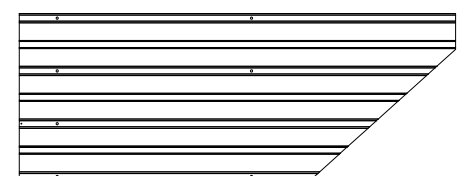

(P8) 2x Roof Panel

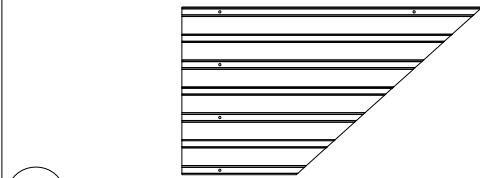

P9 2x Roof Panel

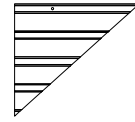

P10 2x Roof Panel

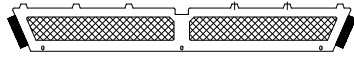

Q 2x Net Frame

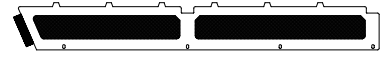

Q1 2x Net Frame

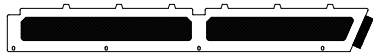

Q2 2x Net Frame

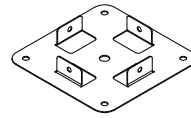

B 4x Post Base

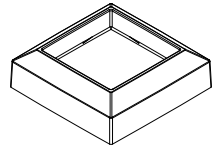

B1 4x Base Cover

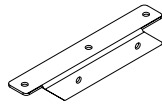

B2 4x Bracket

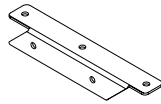

B3 4x Bracket

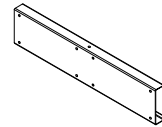

C2 6x Joint Bar

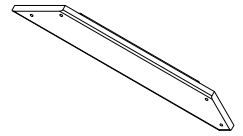

R 4x Corner Solidifying Bar

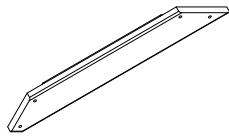

R1 4x Corner Solidifying Bar

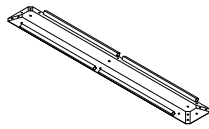

S 1x Inside Roof Cover

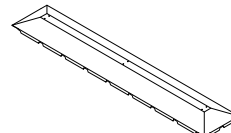

S1 1x Outside Roof Cover

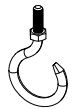

T 3x J-Hook

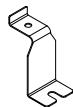

T1 4x Joint Cover

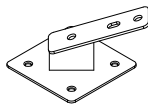

U 4x Bracket

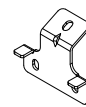

U1 8x Bracket



U2 4x Bracket

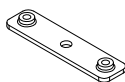

U3 8x Bracket



V 128x Plastic Hook

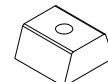

W 136x Spacer



X 6x Joint Cover



X1 4x Corner Cover



X2 10x Finishing End



X3 12x Finishing End

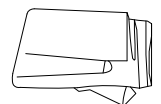

Y 4x Curtain

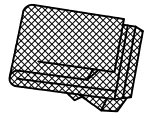

Y1 4x Mosquito Netting



Z 76x Plastic Bracket



Z1 4x Plastic Bracket

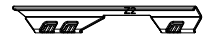

Z2 4x Plastic Bracket

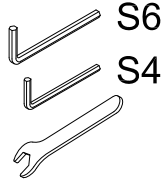

1 1x Wrench



ST6.3x15

2 12x



ST5x16

3 24x

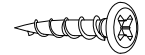

ST5x30

4 16x



M6

5 156x



M6x38

6 16x



M6x10

7 28x



M6x16

8 178x

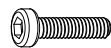

M6x25

9 8x



M6x28

10 84x

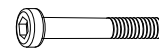

M6x45

11 4x

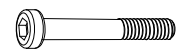

M6x50

12 40x



ST6.3x35

13 32x



ST8x30

14 16x



D6.6*2

15 16x



M3x65

16 1x Drill



M8x160

17 16x

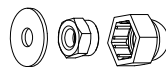

M8

18 16x



19 16x Plastic Cap

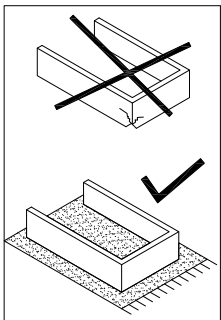



A 4x

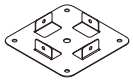

B 4x

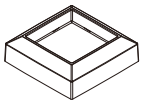

B1 4x



ST6. 3X35

13 16x



M3x65

16 1x

X4

B1

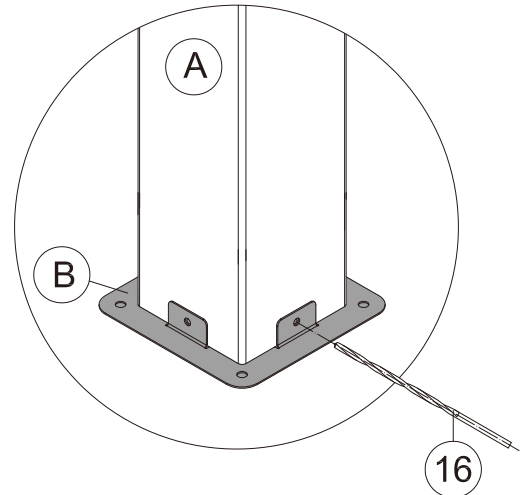
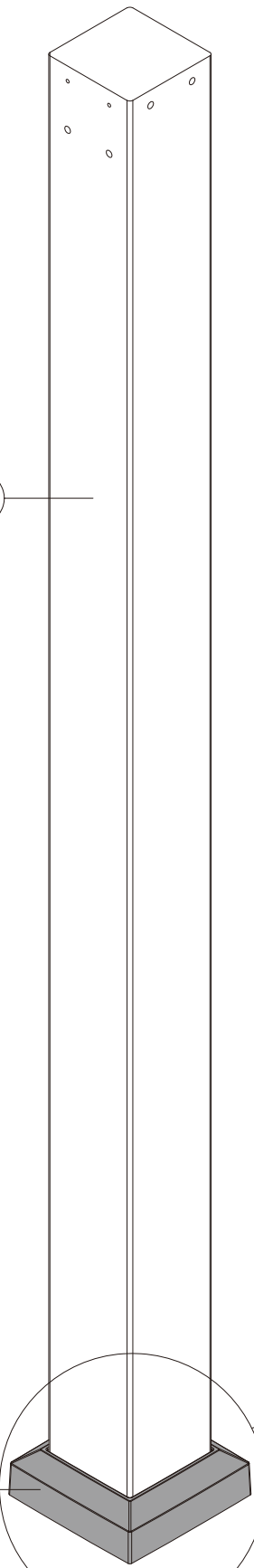

(1) Put Part #B on the bottom of Part #A, after adjusting the position, use Drill #16 to drill holes at the holes in Part #B.

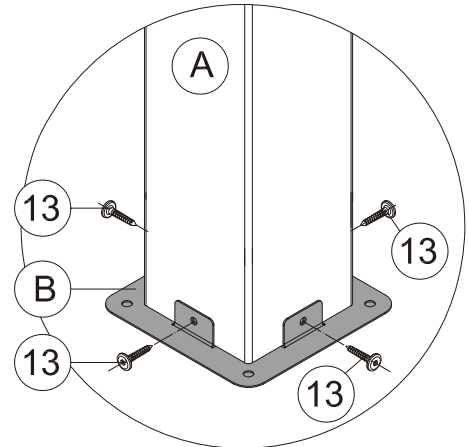

(2) Secure Part #B and Part #A with 4 Bolts #13.

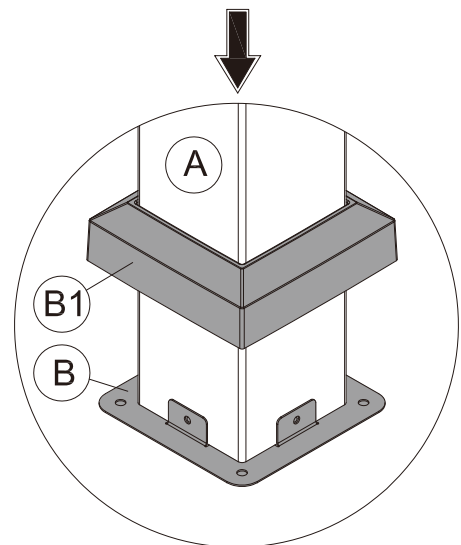

(3) Cover Part #B1 on Part #B.

(4) Repeat the above procedures to assemble the other 3 Part #A.

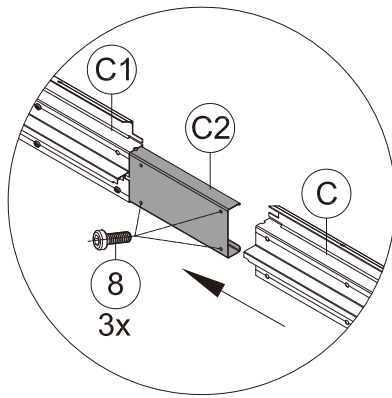
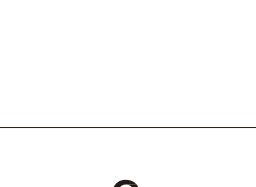
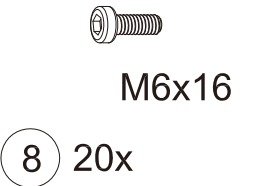
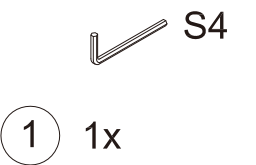
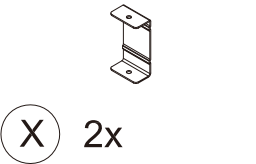
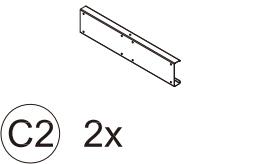
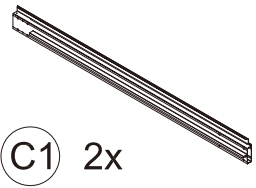
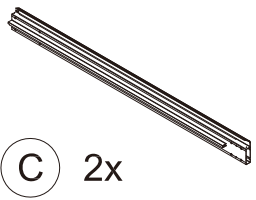

(2) Insert the other side of Part #C2 into Part #C and secure with 3 Bolts #8.

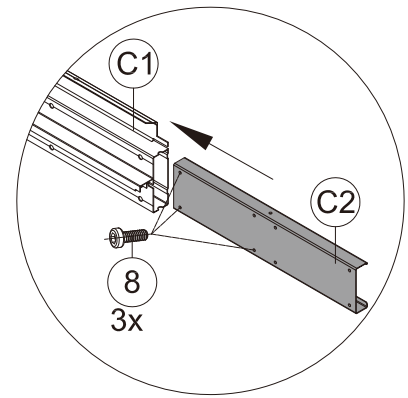

(1) Insert Part #C2 into Part #C1 and secure with 3 Bolts #8.

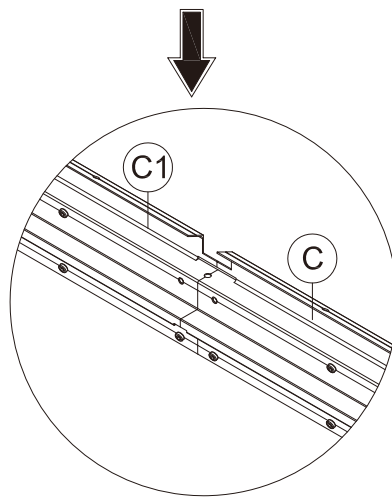

(3) Connect Part #C1 and Part #C through Part #C2.

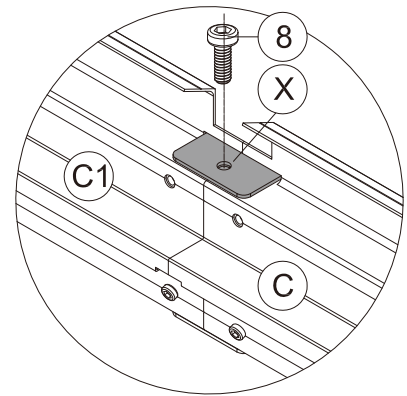

(4) Insert Part #X into the beam and secure with 1 Bolt #8.

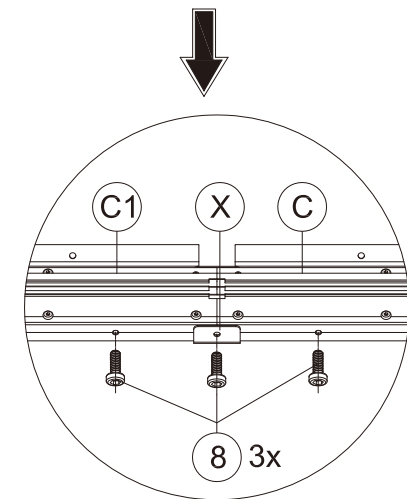



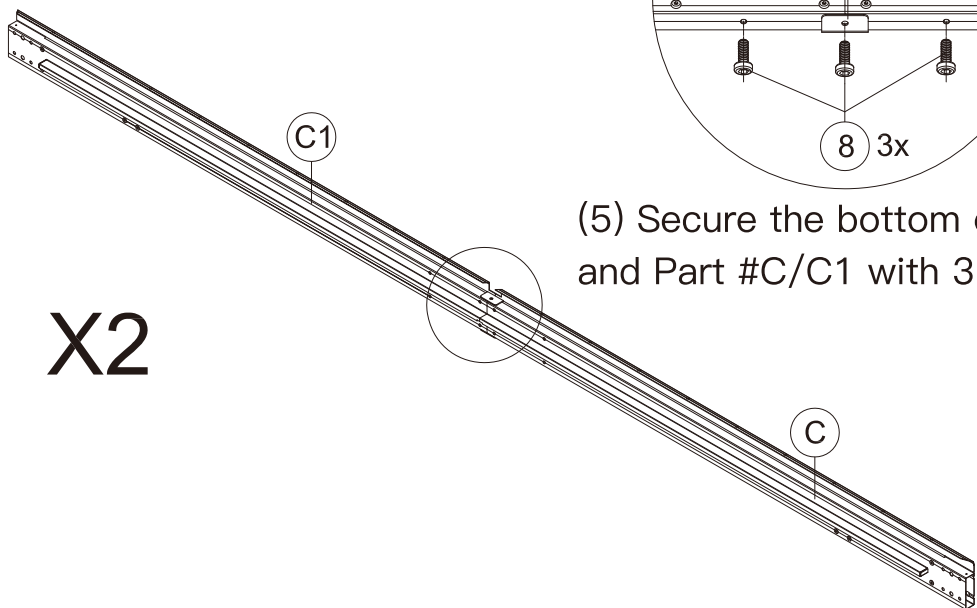



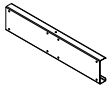

(5) Secure the bottom of Part #X and Part #C/C1 with 3 Bolts #8.

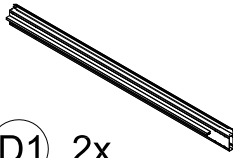
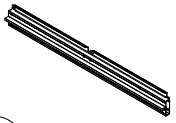

(6) Repeat the above procedures to assemble the other Part #C and Part #C1.

8

-  C2 4x
-  D 2x
-  D1 2x
-  D2 2x
-  X 4x
-  S4
-  1 1x
-  M6x16
-  8 40x

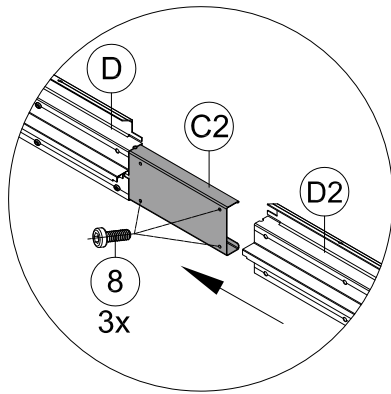

(2) Insert the other side of Part #C2 into Part #D2 and secure with 3 Bolts #8.

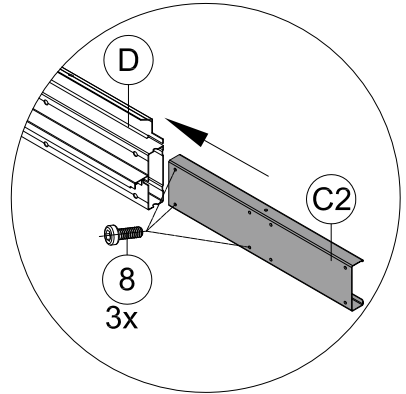

(1) Insert Part #C2 into Part #D and secure with 3 Bolts #8.

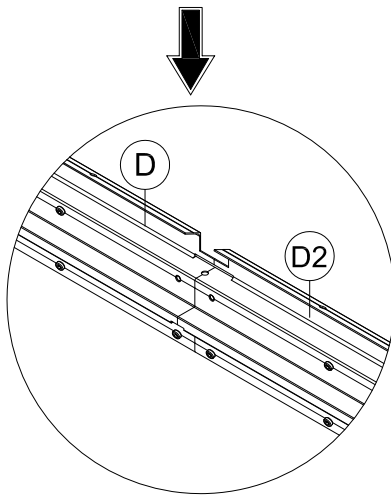

(3) Connect Part #D and Part #D2 through Part #C2.

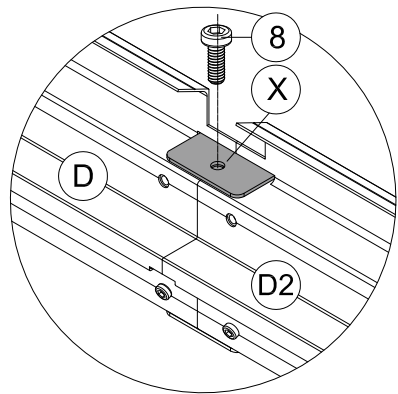

(4) Insert Part #X into the beam and secure with 1 Bolt #8.

(5) Secure the bottom of Part #X and Part #D & #D2 or Part #D2 & #D1 with 3 Bolts #8.

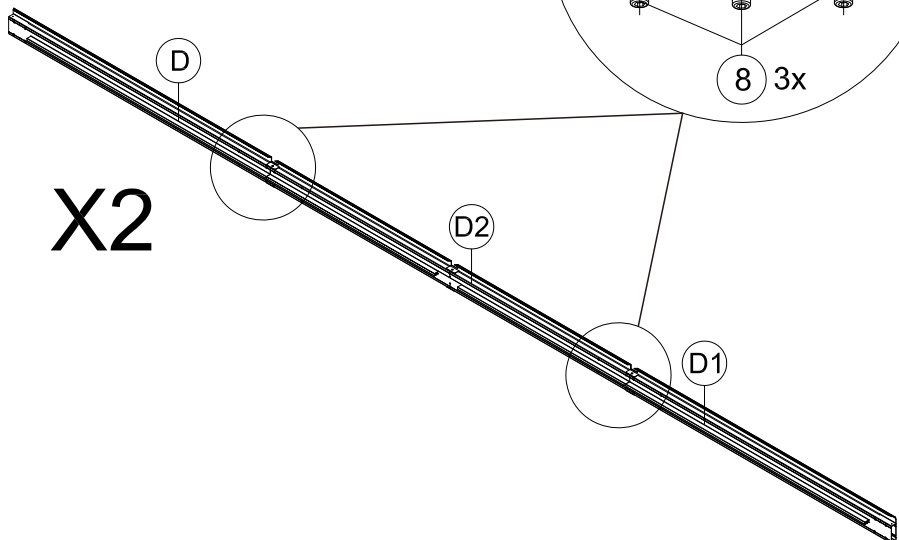
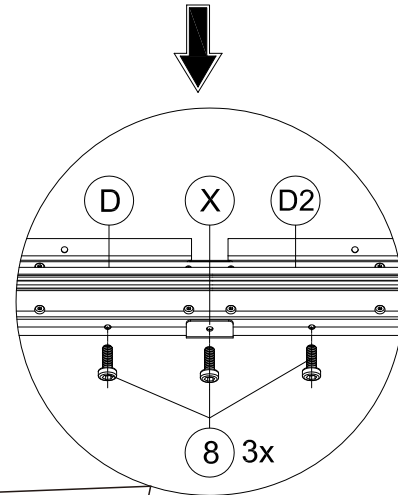

(6) Repeat the above procedures to assemble the other Part #D & #D1 & #D2.

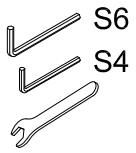

1 1x



14 16x



17 16x

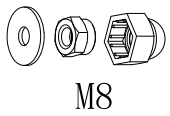

18 16x

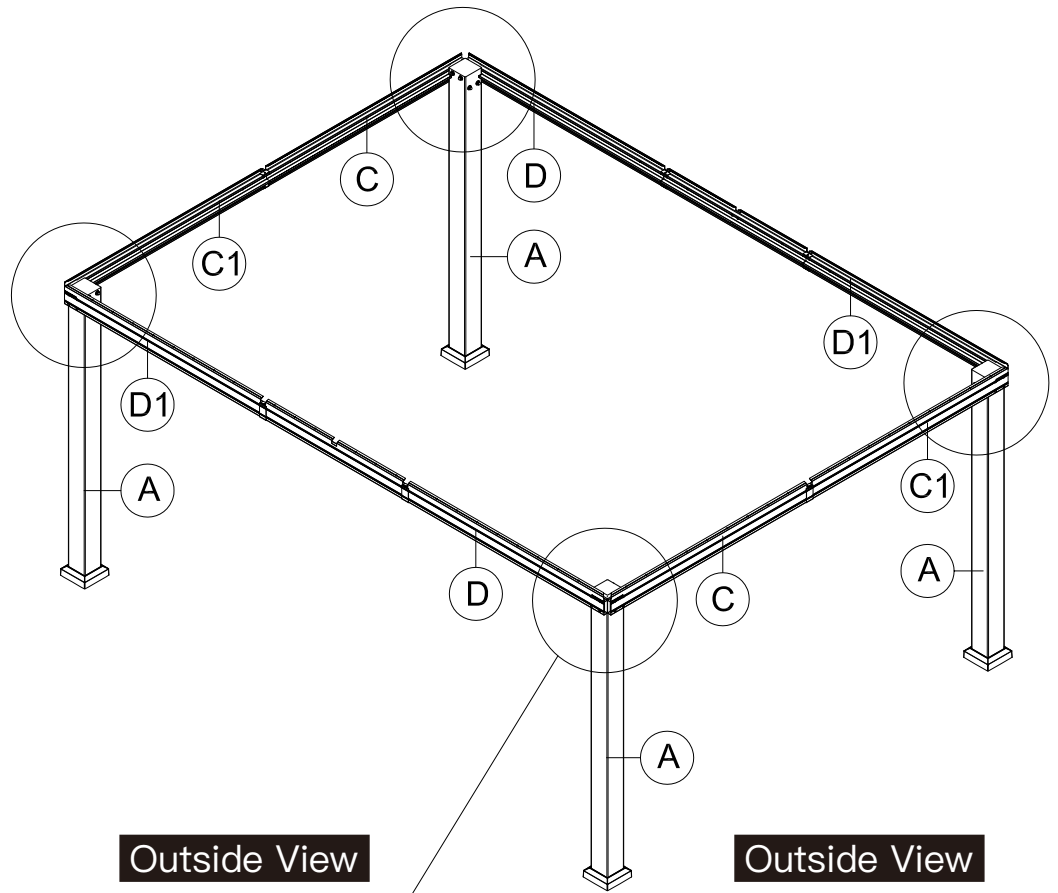

Outside View

Outside View

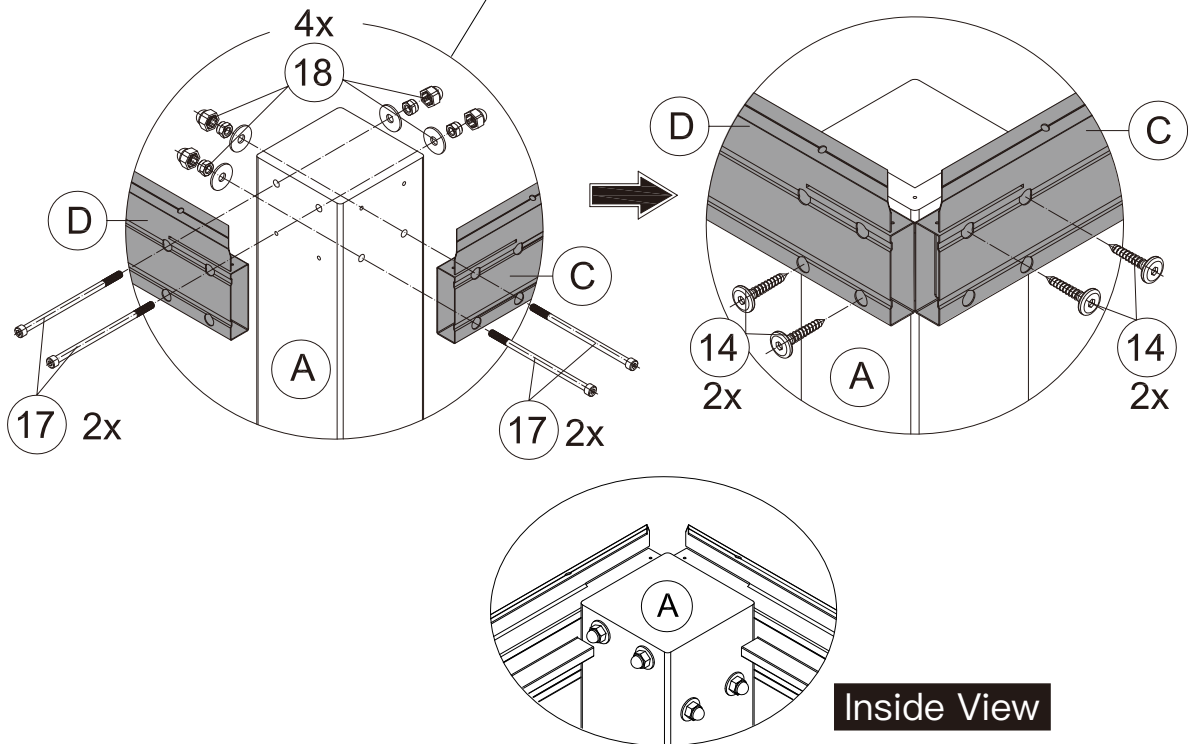

Inside View

(1) Connect Part #D to Part #A with 2 Bolts #17, and fix from the other side with 2 gaskets and nuts #18. **(The first row of screw holes)**

(2) Connect Part #C to Part #A with 2 Bolts #17, and fix from the other side with 2 gaskets and nuts #18. **(The second row of screw holes)**

(3) Secure Part #D & #C with 4 Bolts #14 as shown.

(4) Repeat the above procedures to assemble the other 3 corners.

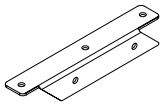

(B2) 4x

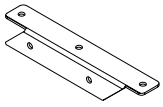

(B3) 4x

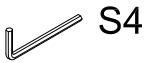

(1) 1x



M6x16

(8) 16x

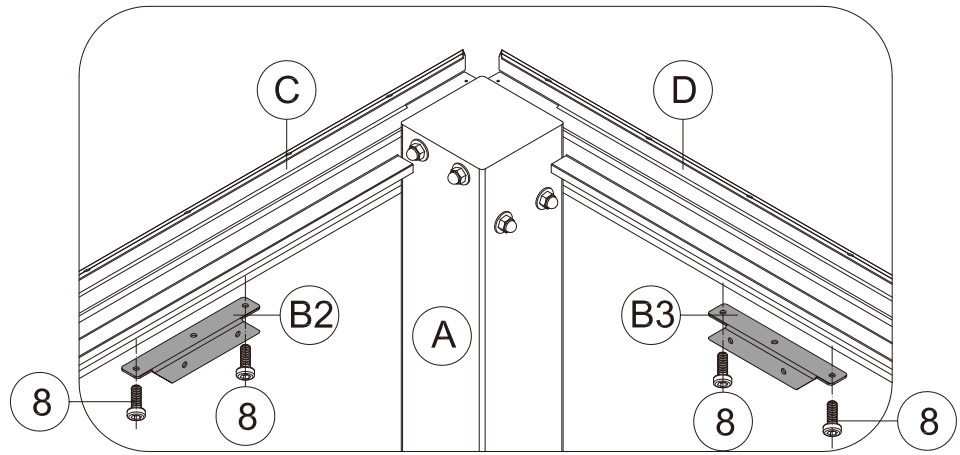

(1) Affix Part #B2 and Part #B3 to the Beam with 4 Bolts #8.

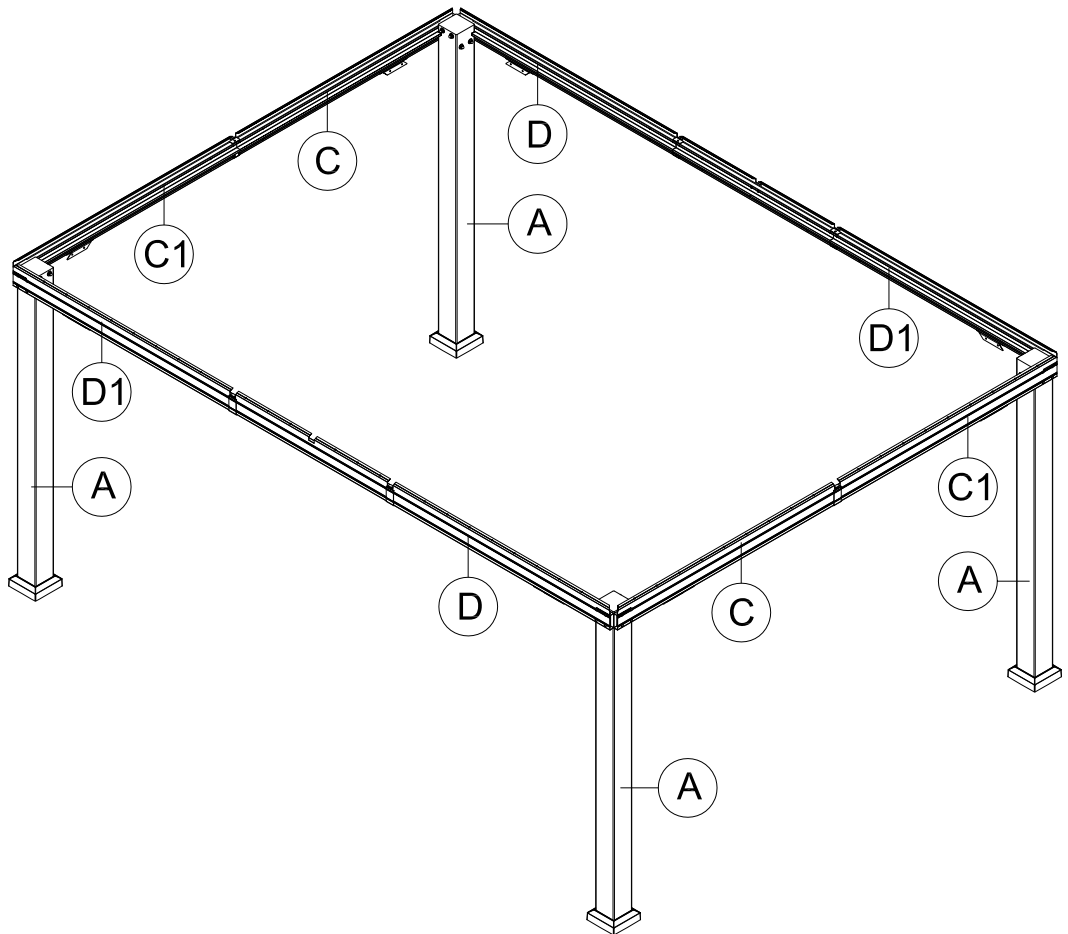

(2) Repeat the above procedures to assemble the other 3 corners.

⚠ Please don't tighten all bolts.

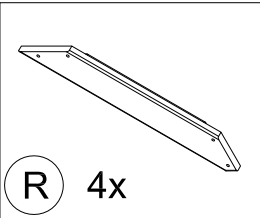

R 4x

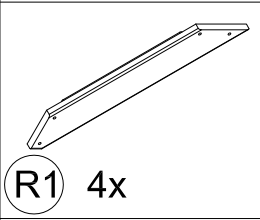

R1 4x

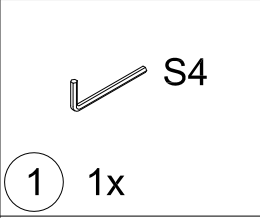

1 1x

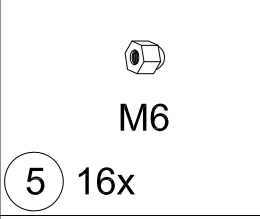

5 16x

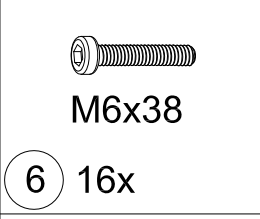

6 16x

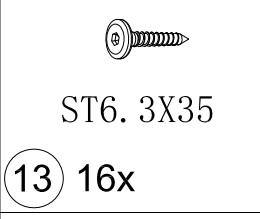

13 16x

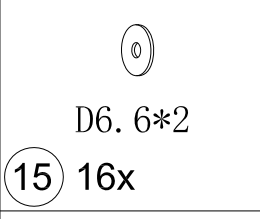

15 16x

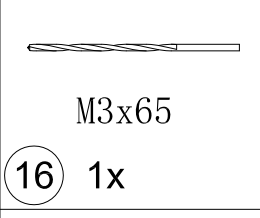

16 1x



12

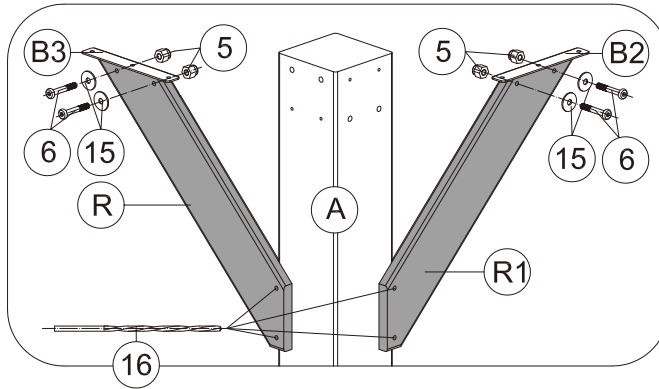

(1) Affix Part #R to Part #B3 with 2 Bolts #6, 2 Washers #15 and 2 Nuts #5.

(2) Affix Part #R1 to Part #B2 with 2 Bolts #6, 2 Washers #15 and 2 Nuts #5.

Outside View

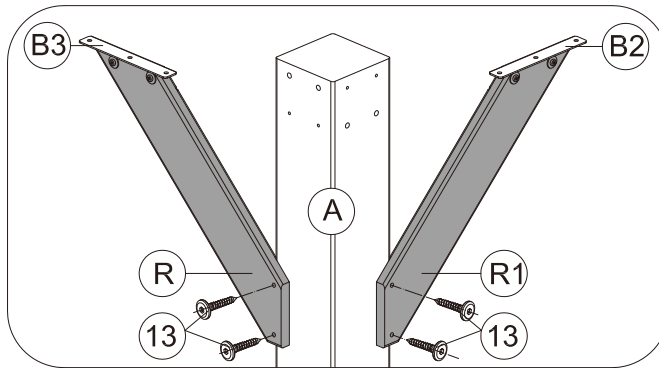

⚠ (3) Use Drill #16 to drill holes in the holes reserved for Part #R/#R1.

(4) Affix Part #R and Part #R1 to the poles with 4 Bolts #13.

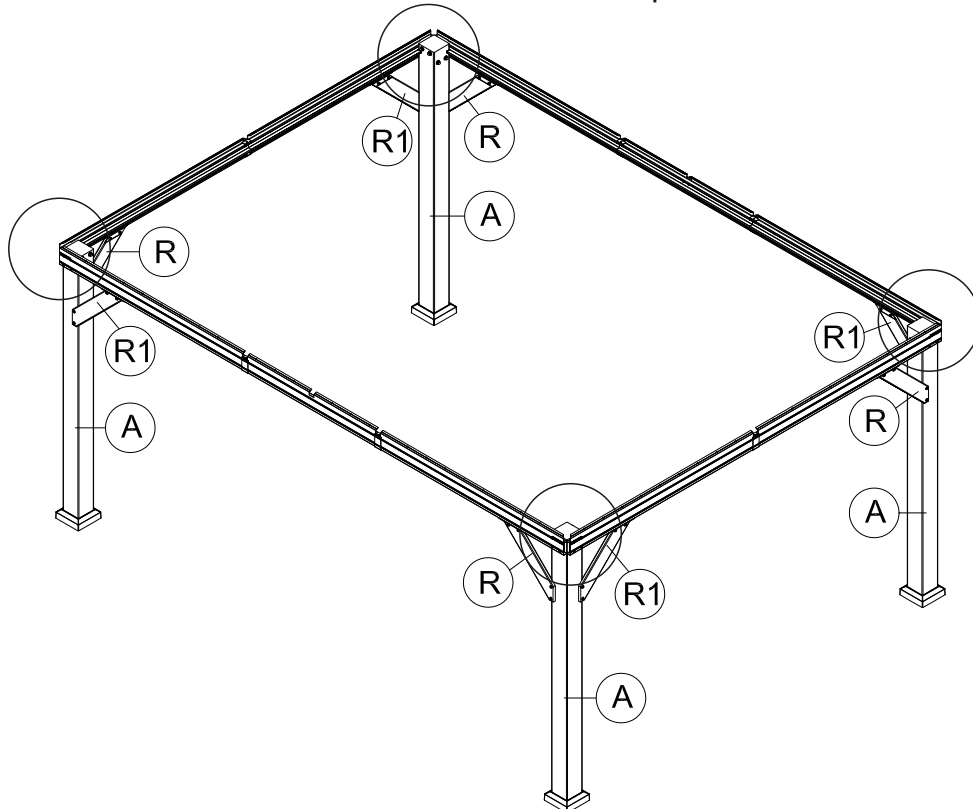

(5) Repeat the above procedures to assemble the other 3 corners.

⚠ Tighten all the bolts.

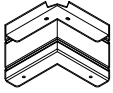

X1 4x



ST5x16

3 16x



19 16x

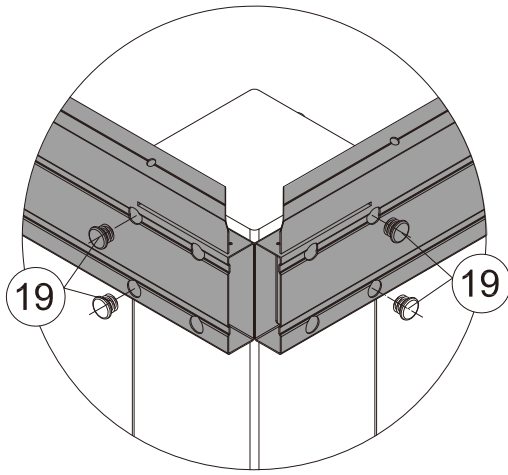

(1) Put 4 Part #19 on the 4 holes.

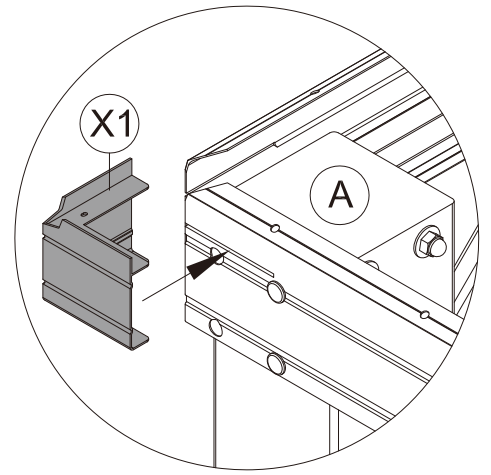

(2) Cover the corner with Part #X1.

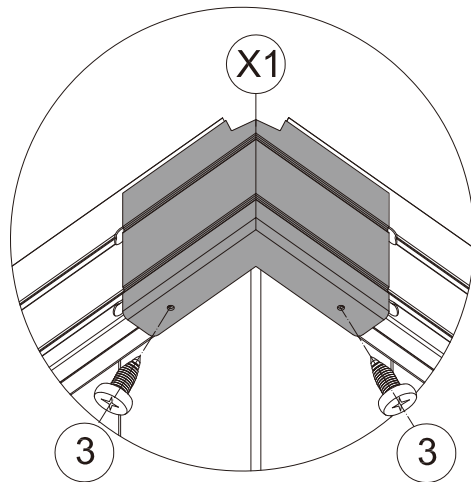

(4) Secure with 2 Self-tapping Screws #3. (from bottom to top)

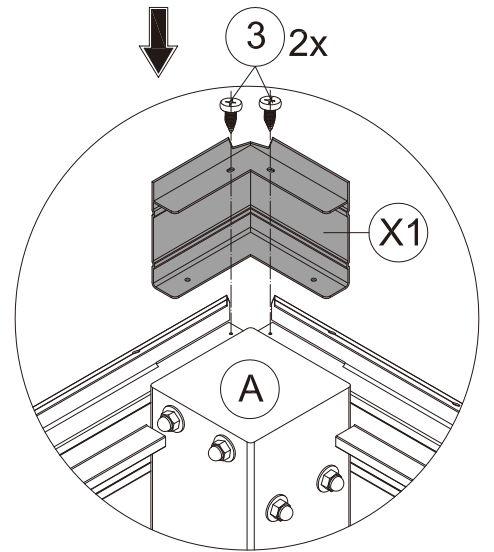

(3) Secure with 2 Self-tapping Screws #3. (from top to bottom)

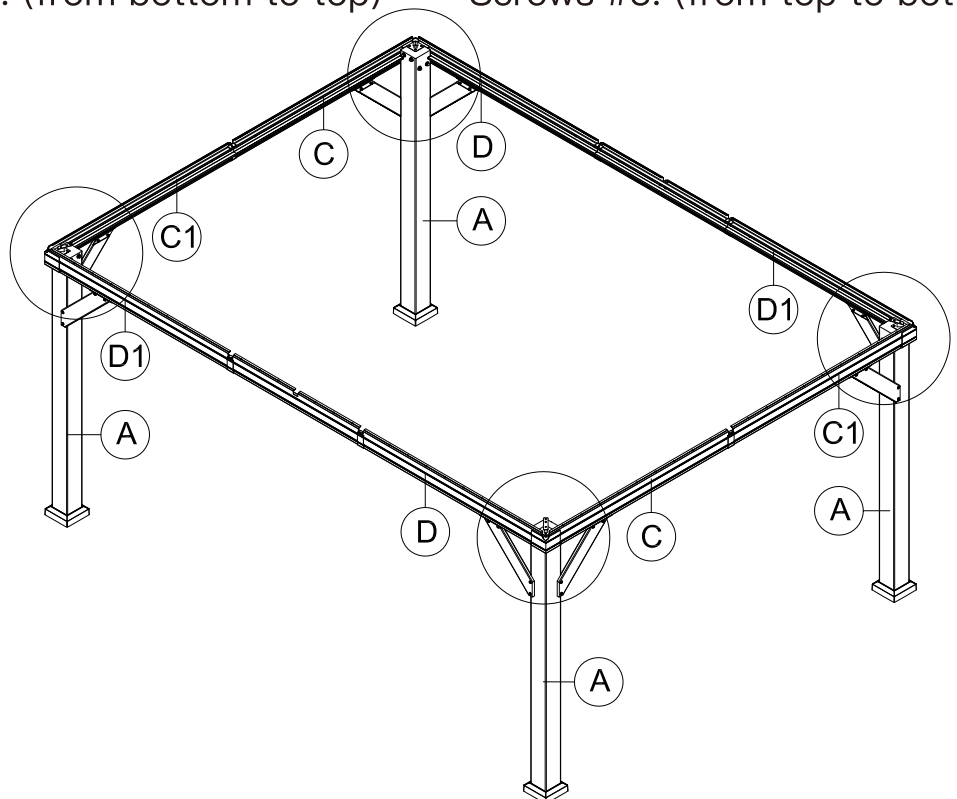

(5) Repeat the above procedures to assemble the other 3 corners.

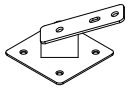

U 4x

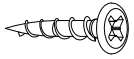

ST5x30

4 16x

(1) Connect Part #U to Part #A with 4 Bolts #4.

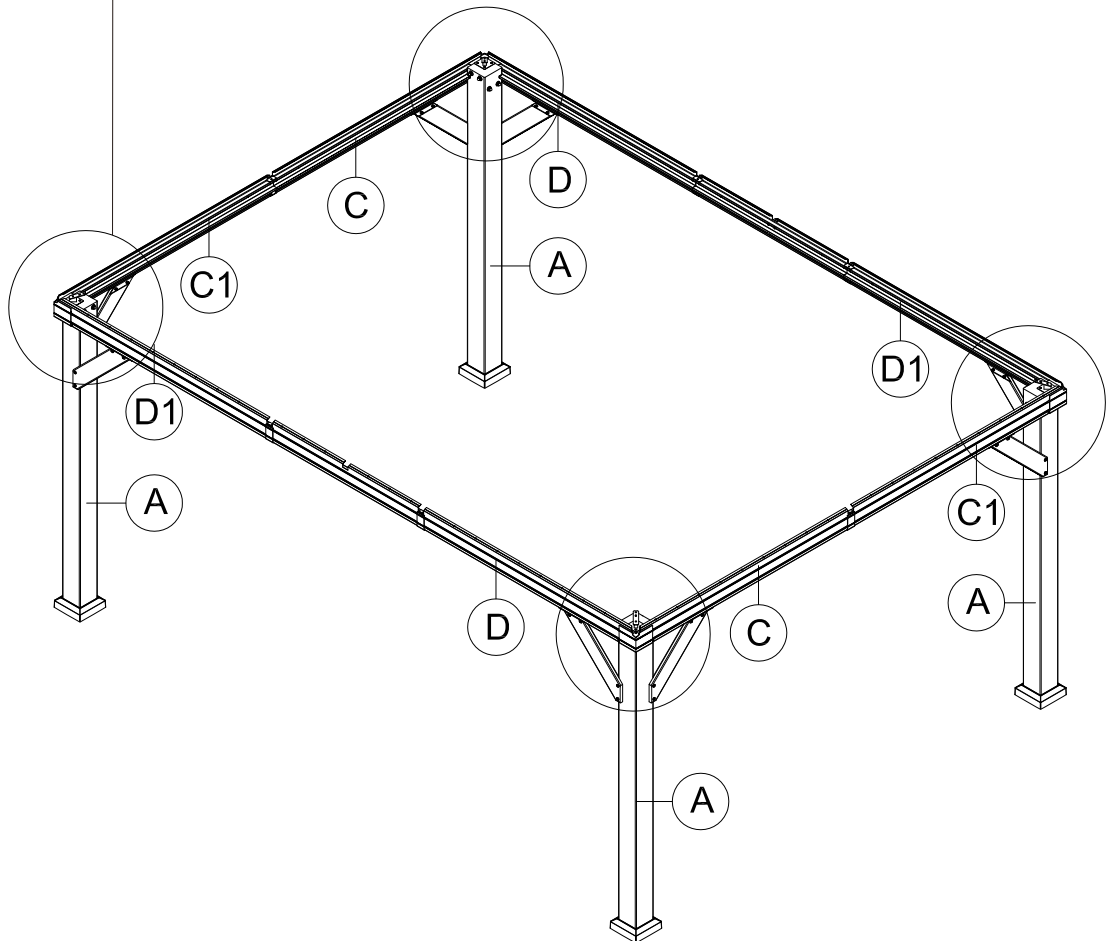
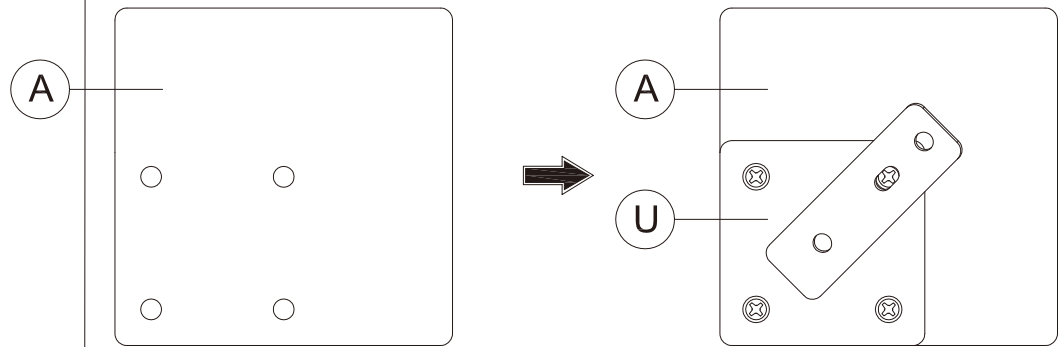
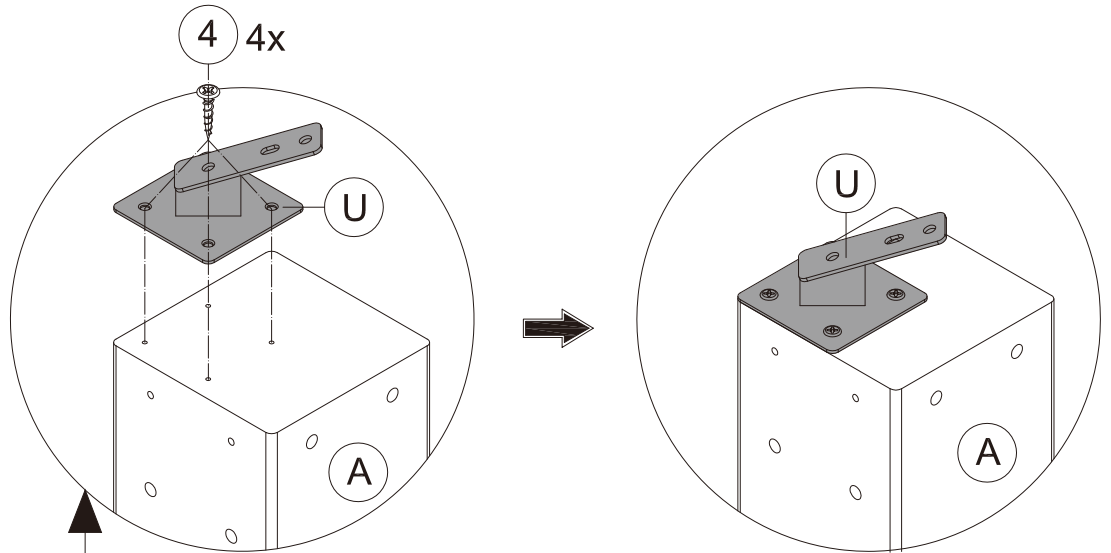

(2) Repeat the above procedures to assemble the other 3 corners.

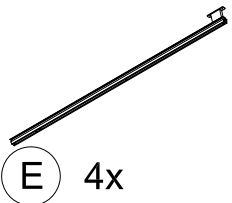

E 4x

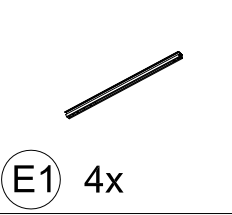

E1 4x

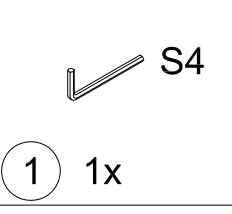

1 1x

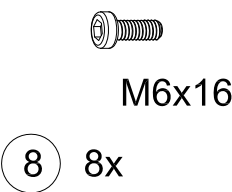

M6x16

8 8x

Assemble the 4 Corner Roof Bars:

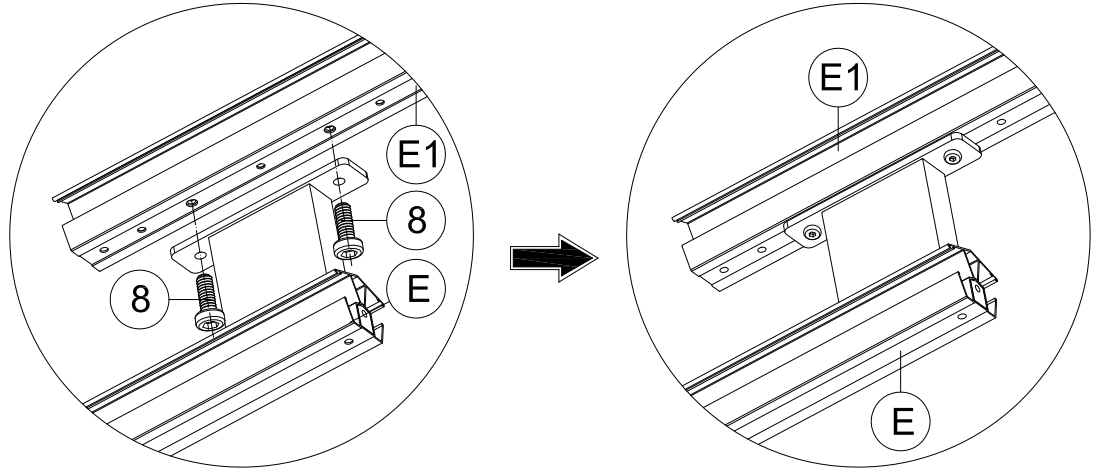

(1) Connect Part #E1 and Part #E with 2 Bolts #8 .

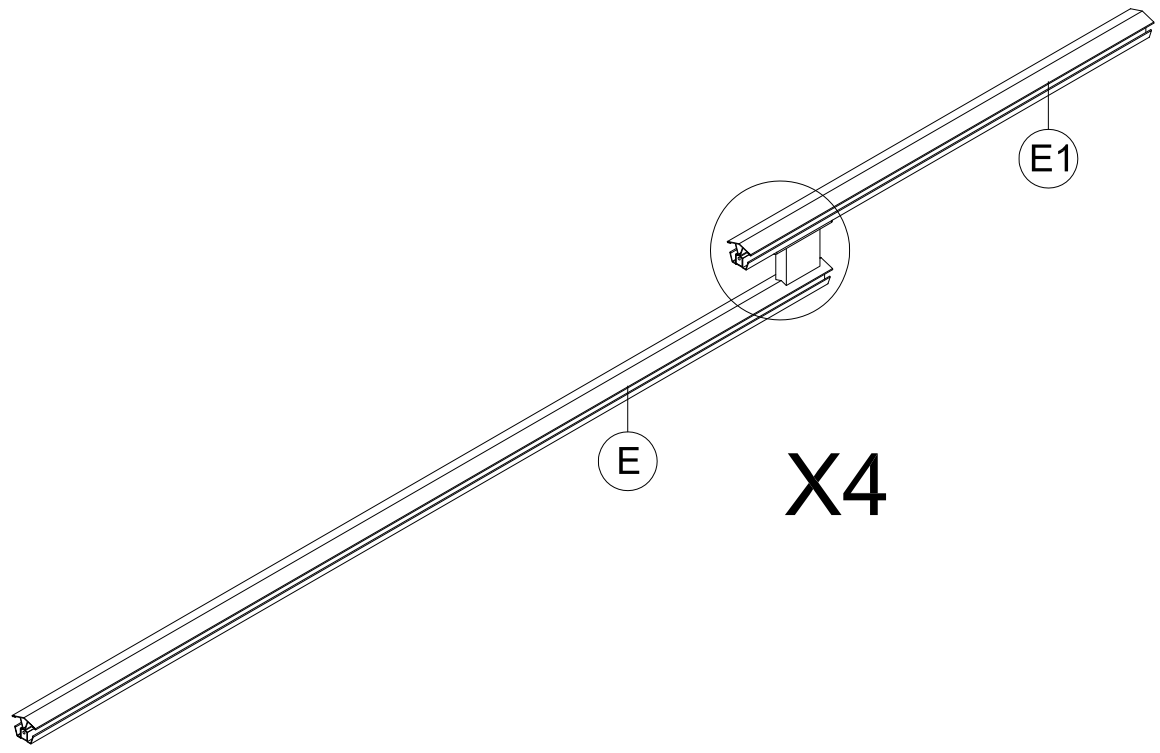

(2) Repeat the above procedures to assemble the other 3 corner roof bars.

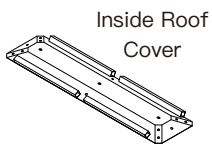

Inside Roof Cover

S 1x

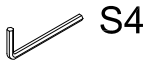

S4

1 1x



M6x16

8 16x

Please have a freestanding ladder ready at the center of the gazebo.

(1) Place 4 Part #E1 on the 4 corners of Part #S. Secure with 8 Bolts #8 (from bottom to top)

ATTENTION: You can also finish this step on the ground and then lift 4 corner roof bar and inside roof connector to the top together. (Need 2 people and 2 ladder)

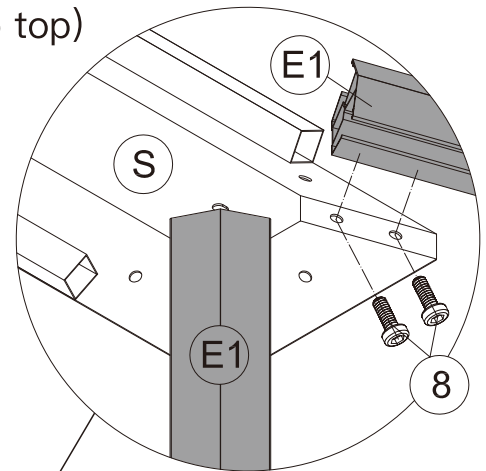



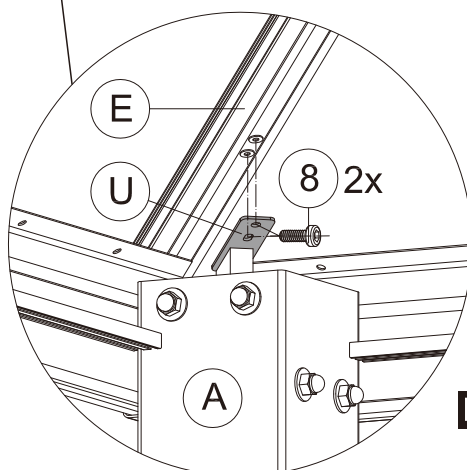
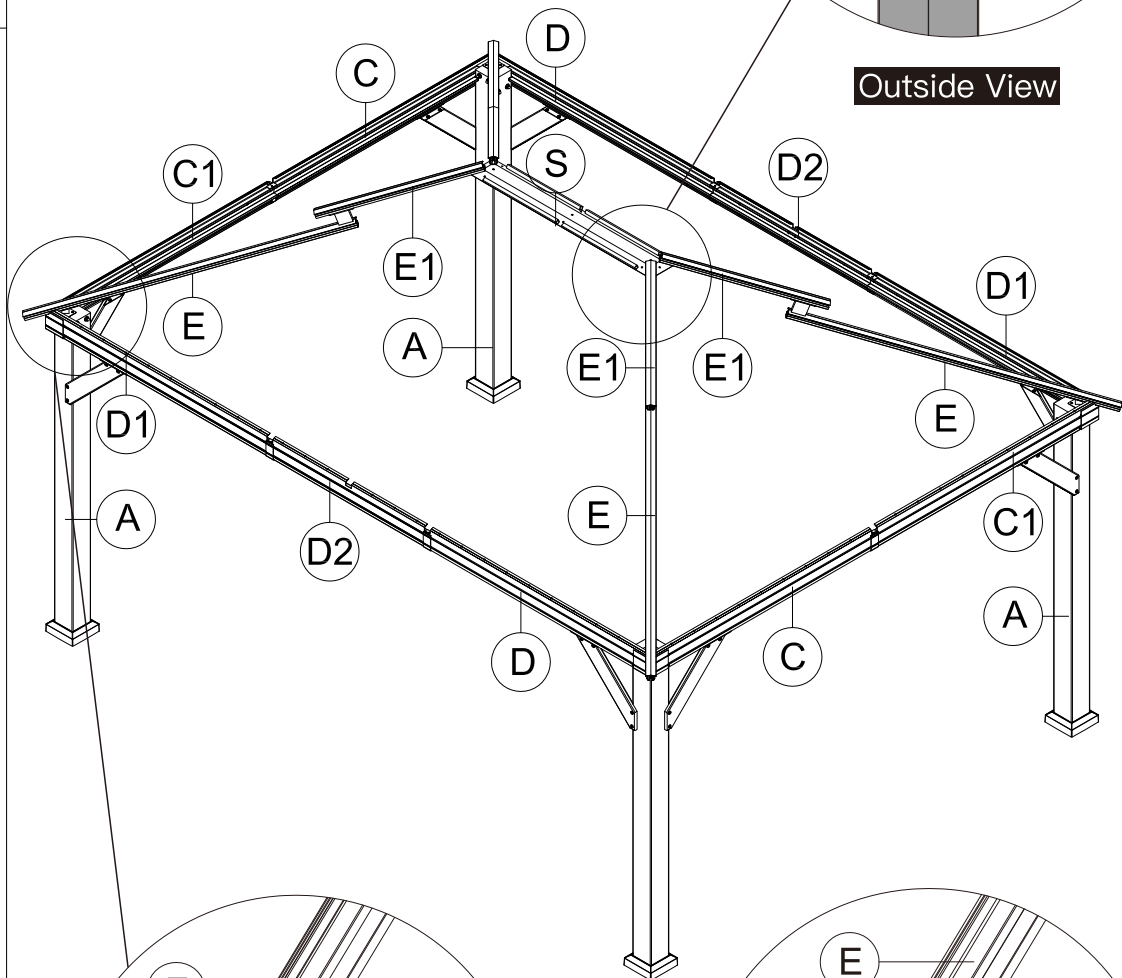

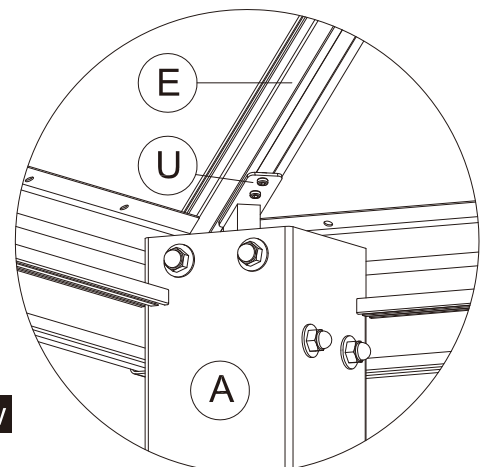

Outside View

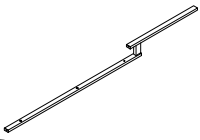

Inside View



(2) Place 4 Part #E on 4 Part #A; Secure with 4 Part U and 8 Bolts #8.

-  E2 8x
-  U1 8x
-  S4
-  1 1x
-  M6x10
-  7 8x

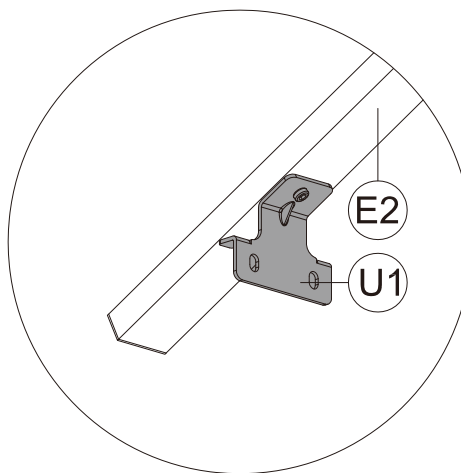
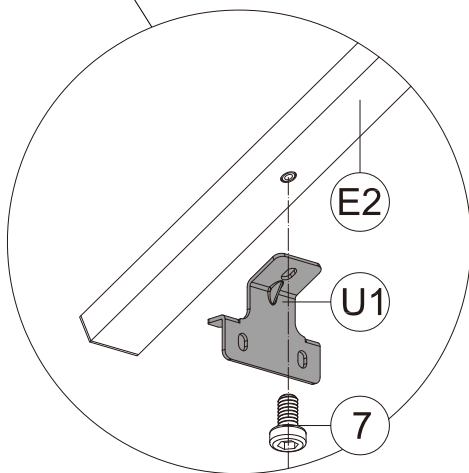
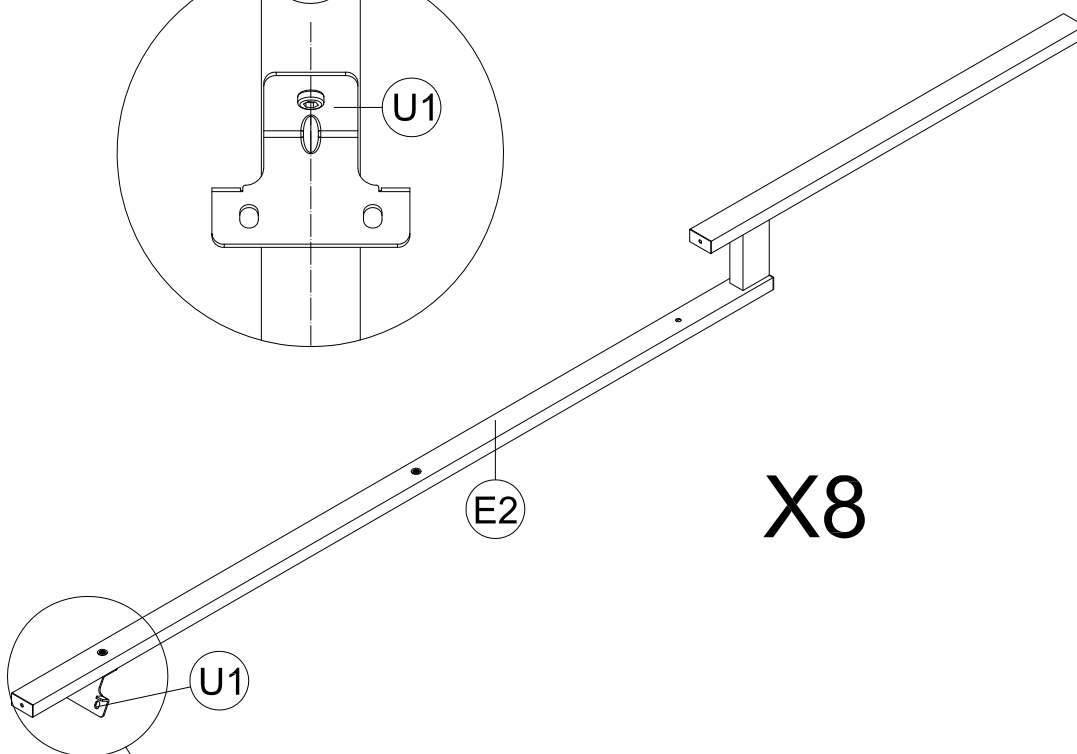
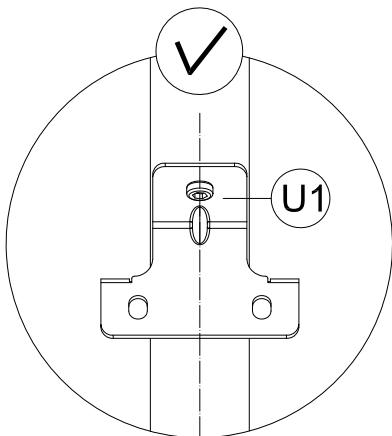
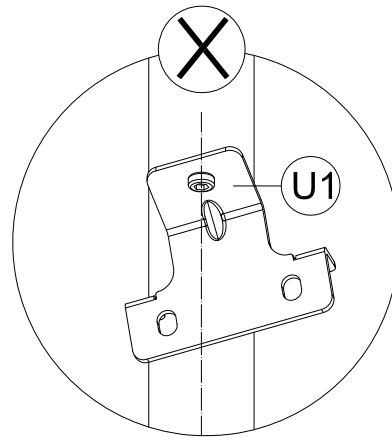
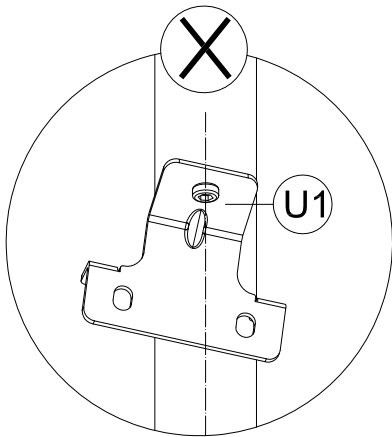

(1) Attach Part #U1 to Part #E2 with Bolt #7 .
 (2) Repeat the above procedures to assemble the other 7 roof bars.

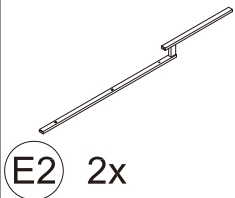

E2 2x

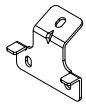

U1 2x



1 1x



M6x16

8 6x

(1) Place Part #E2 on Part #S.
Secure with Bolt #8 (from bottom to top).

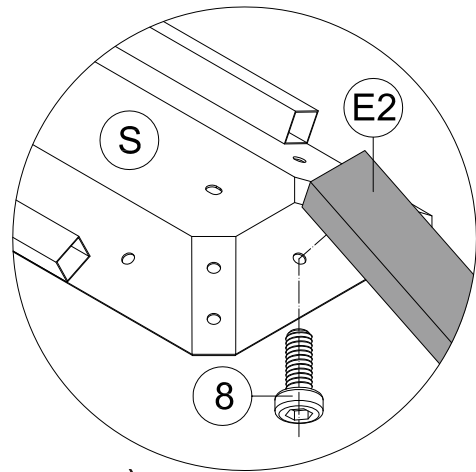

Outside View

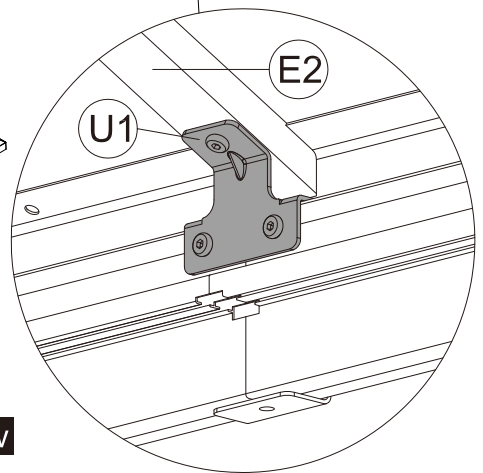
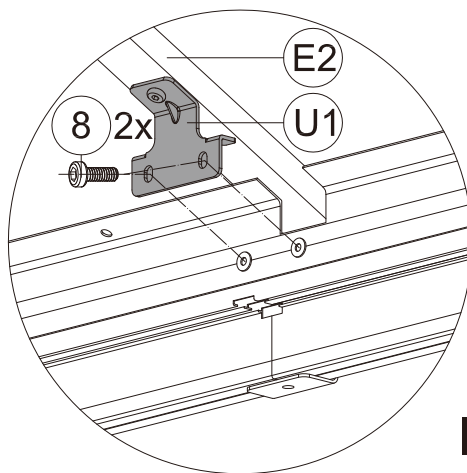
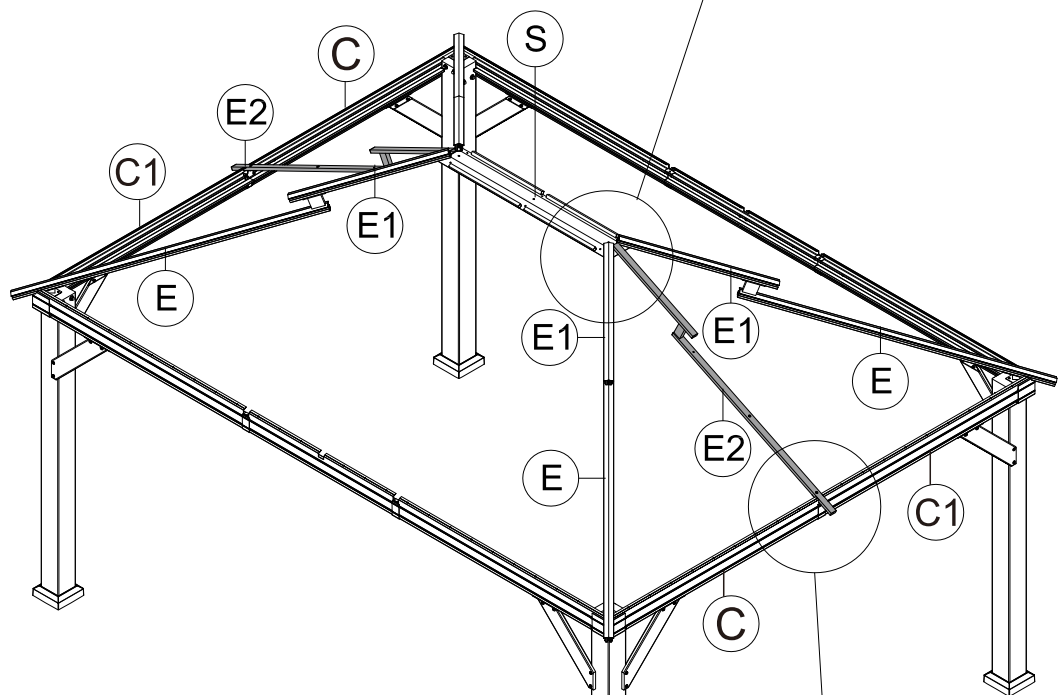

Inside View

(2) Connect Part #E2 and the Assembled Beam(C&C1) with part #U1.
Secure with 2 Bolts #8 .

(3) Repeat the above procedures to assemble the opposite side.

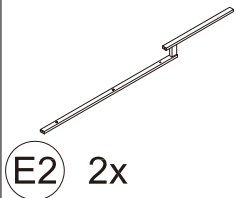

E2 2x

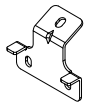

U1 2x

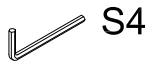

1 1x



M6x16

8 6x

(1) Place Part #E2 on part #S. Secure with Bolt #8 (from bottom to top).

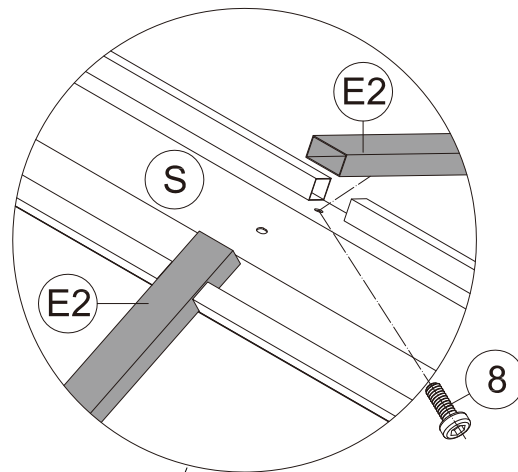

Outside View

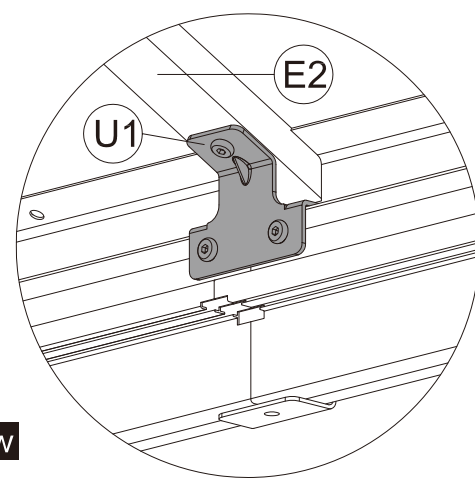
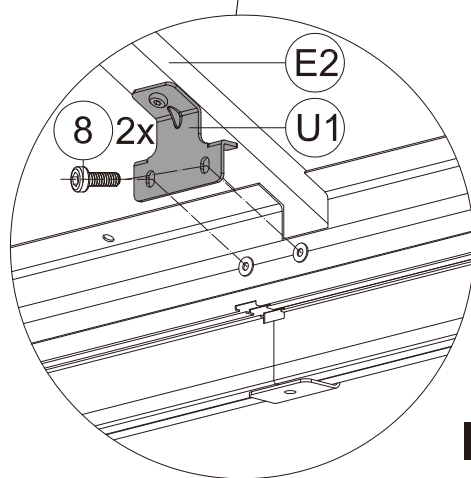
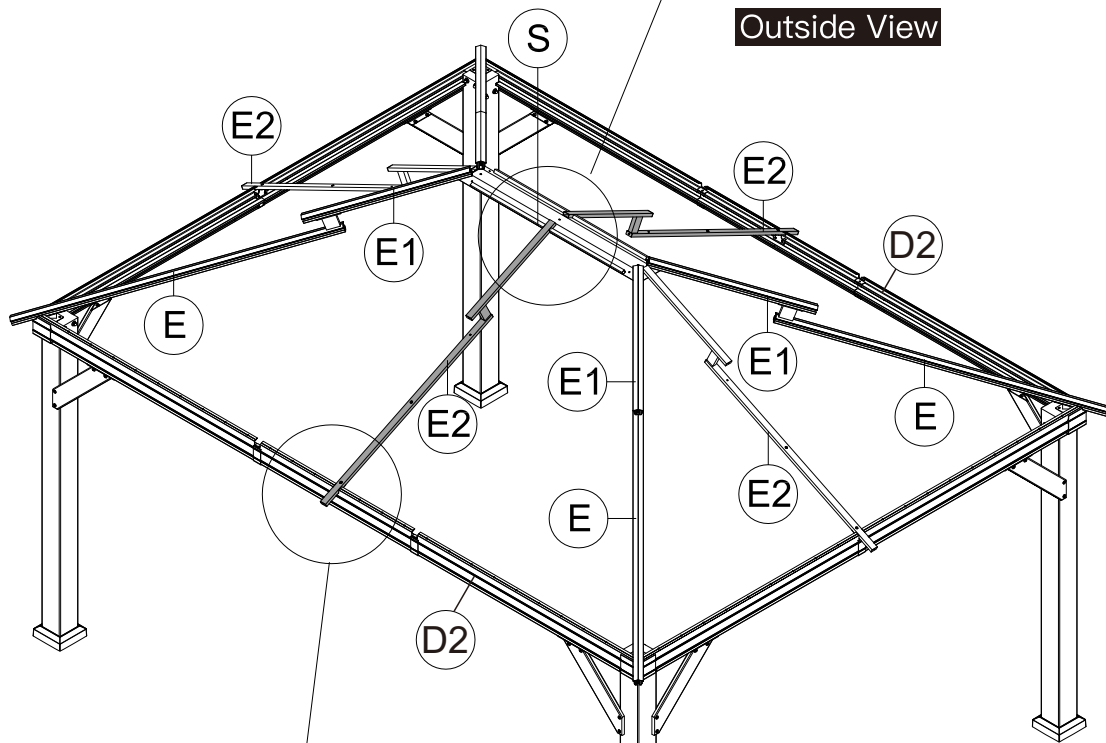

Inside View

(2) Connect Part #E2 and the Assembled Beam(C&C1) with part #U1. Secure with 2 Bolts #8 .

(3) Repeat the above procedures to assemble the opposite side.

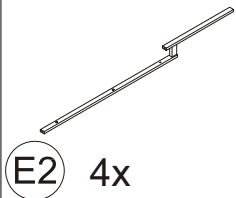

E2 4x

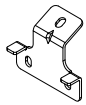

U1 4x



1 1x



M6x16

8 6x

(1) Place Part #E2 on part #S. Secure with Bolt #8 (from bottom to top).

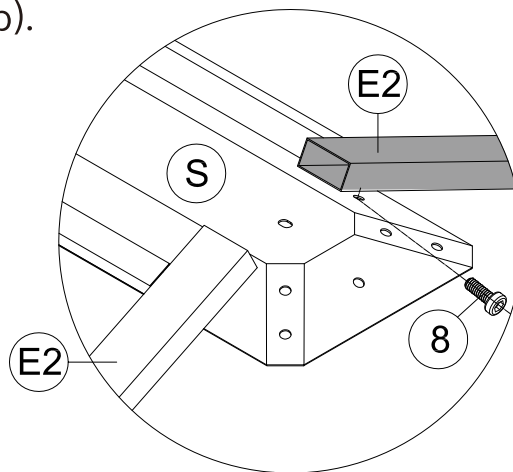

Outside View

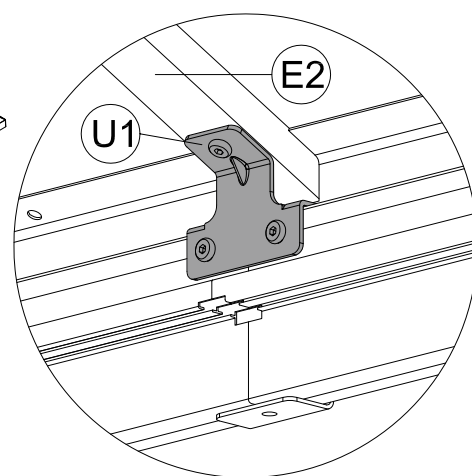
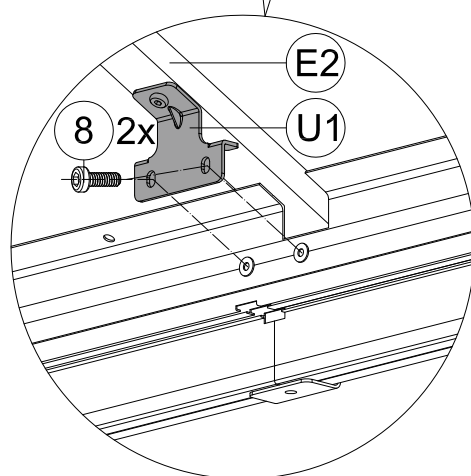
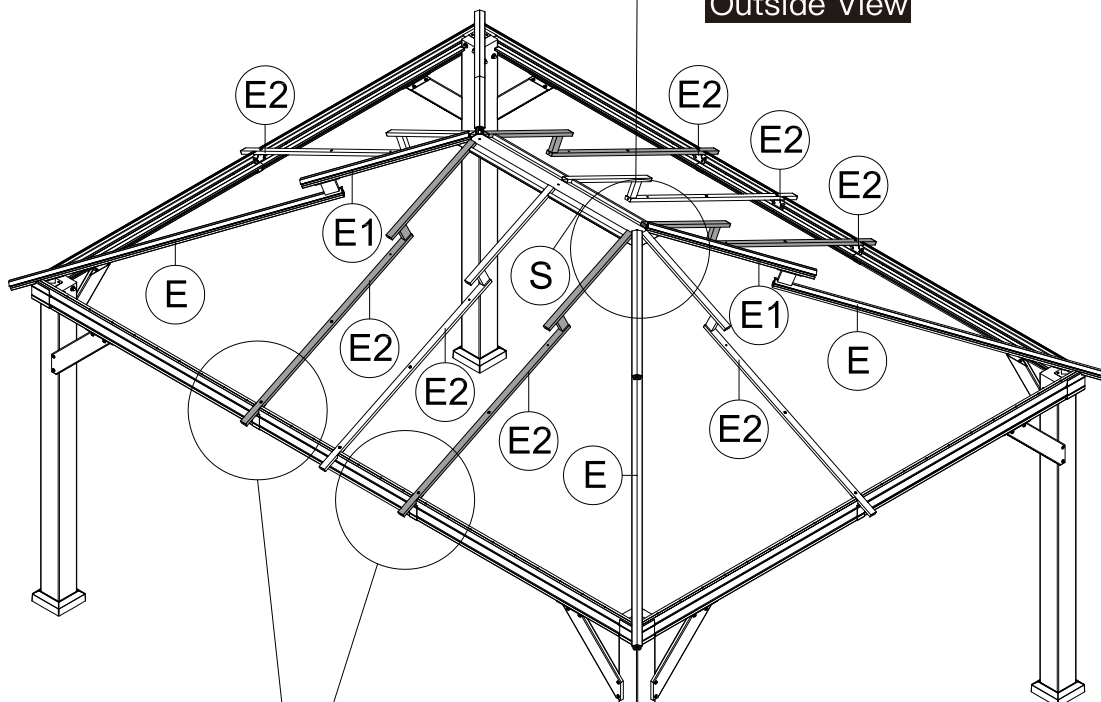

(2) Connect Part #E2 and the Assembled Beam (D1&D2&D) with part #U1. Secure with 2 Bolts #8.

(3) Repeat the above procedures to assemble the opposite side.

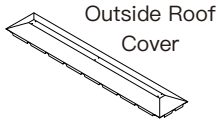

(S1) 1x

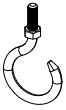

(T) 3x

Secure Part #T to Part #S and Part #S1.
(From Bottom to Top)

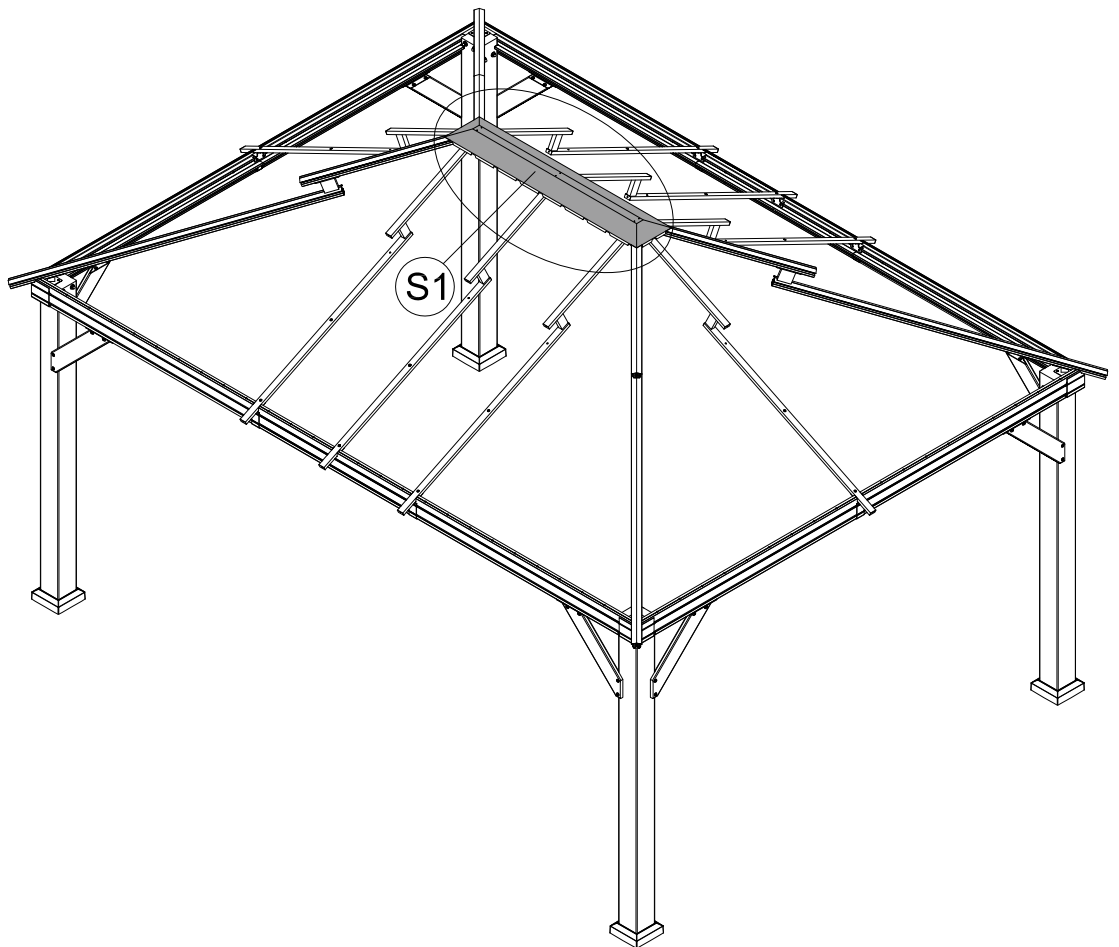
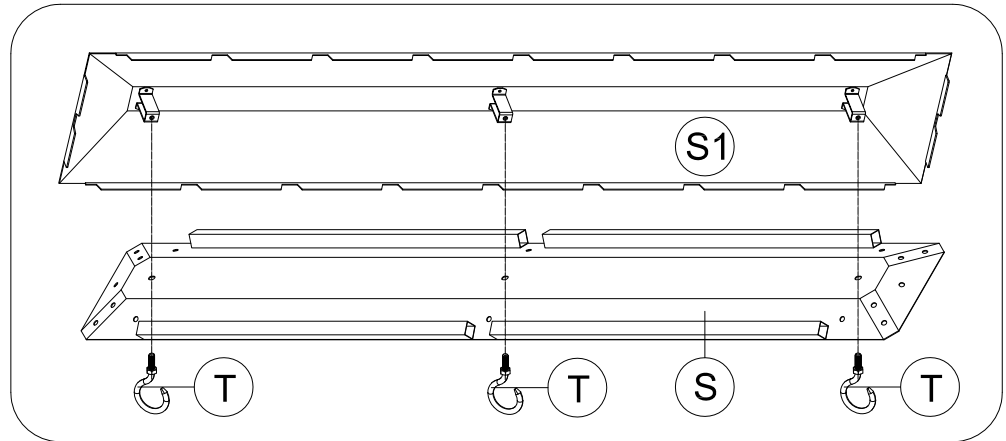

ATTENTION: The holes of Part #S and Part #S1 need to be aligned,
on the same vertical line.

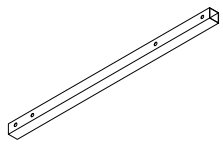

G1 4x

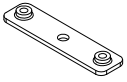

U3 6x

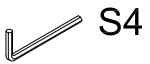

1 1x



M6x10

7 6x



M6x16

8 8x

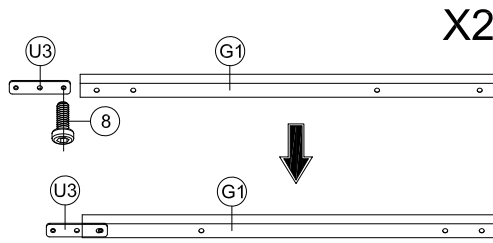

(1) Insert Part #U3 into Part #G1 and secure with Bolt #8.

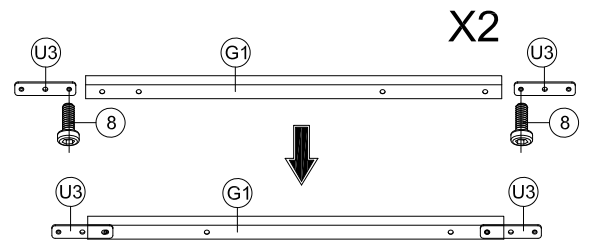

(2) Insert 2 Part #U3 into Part #G1 and secure with 2 Bolts #8.

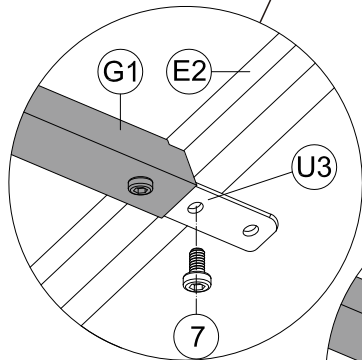
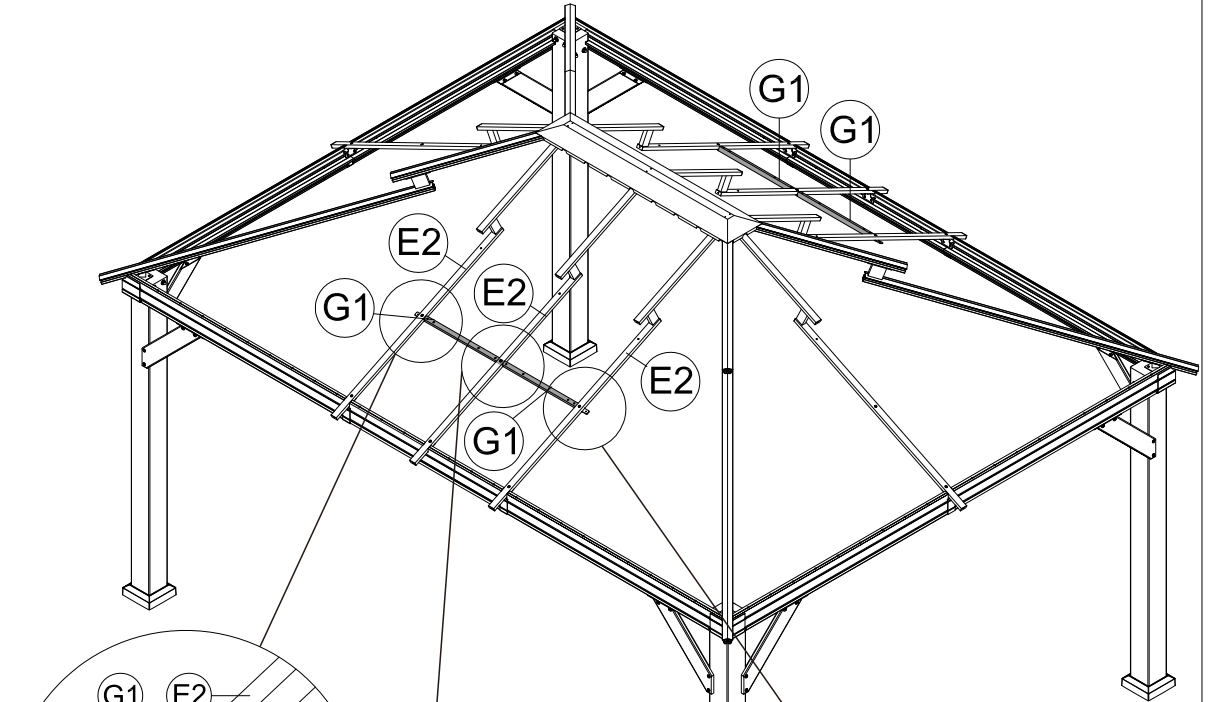

(3) Attach Part #G1 and Part #U3 to Part #E2 with Bolt #7.

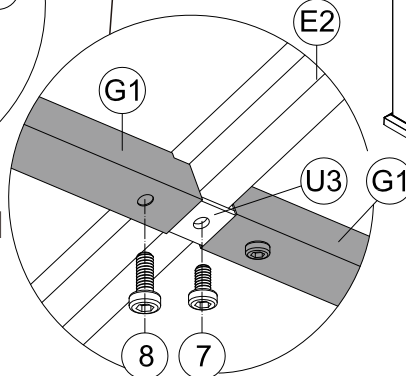

(4) Attach Part #G1 and Part #U3 to Part #E2 with Bolt #7 and Bolt #8.

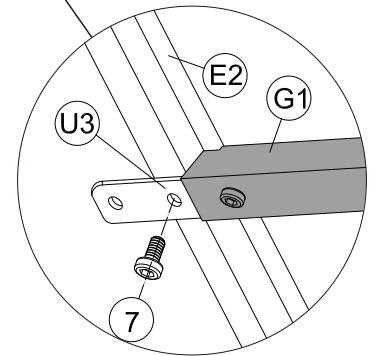

(5) Attach Part #G1 and Part #U3 to Part #E2 with Bolt #7.

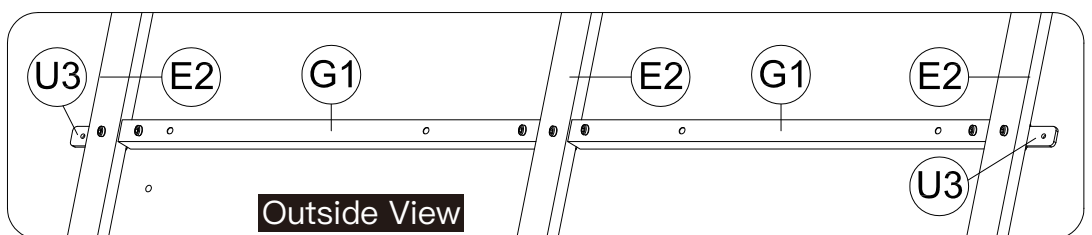

(6) Repeat the above procedures to assemble the opposite side.

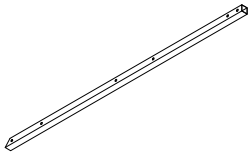

G 4x

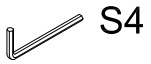

1 1x



M6x16

8 4x

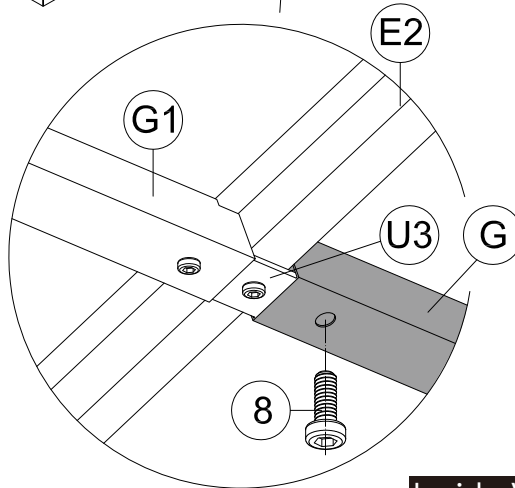
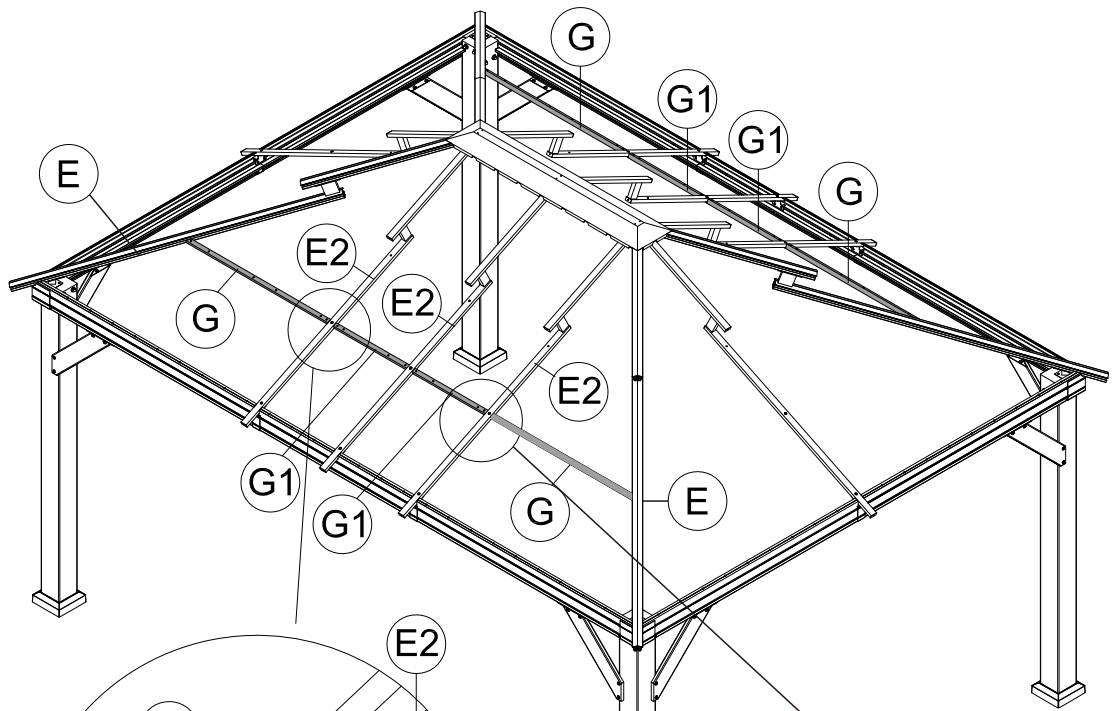

Inside View

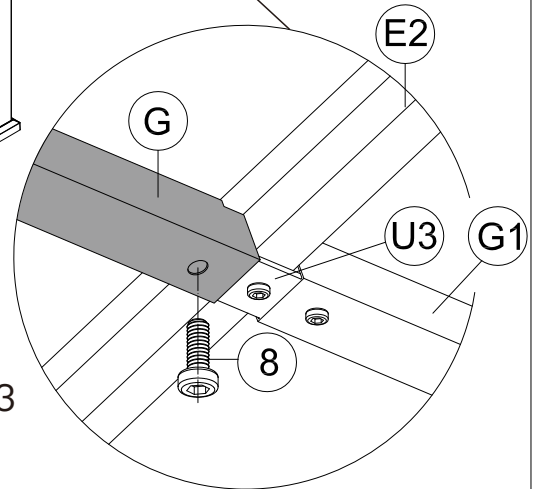

(1) Attach Part #G and Part #U3 to Part #E2 with Bolt #8

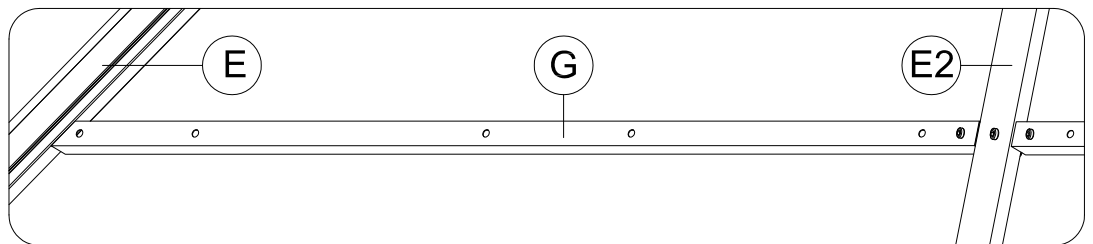

Outside View

(2) Repeat the above procedures to assemble the opposite side.

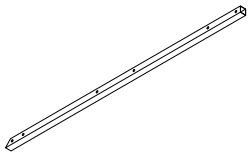

F 4x

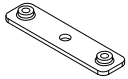

U3 2x

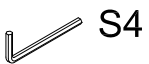

1 1x



M6x10

7 2x



M6x16

8 4x

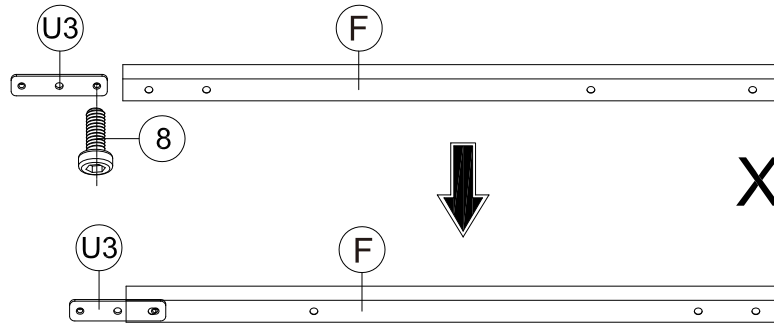

(1) Insert Part #U3 into Part #F and secure with Blot #8.

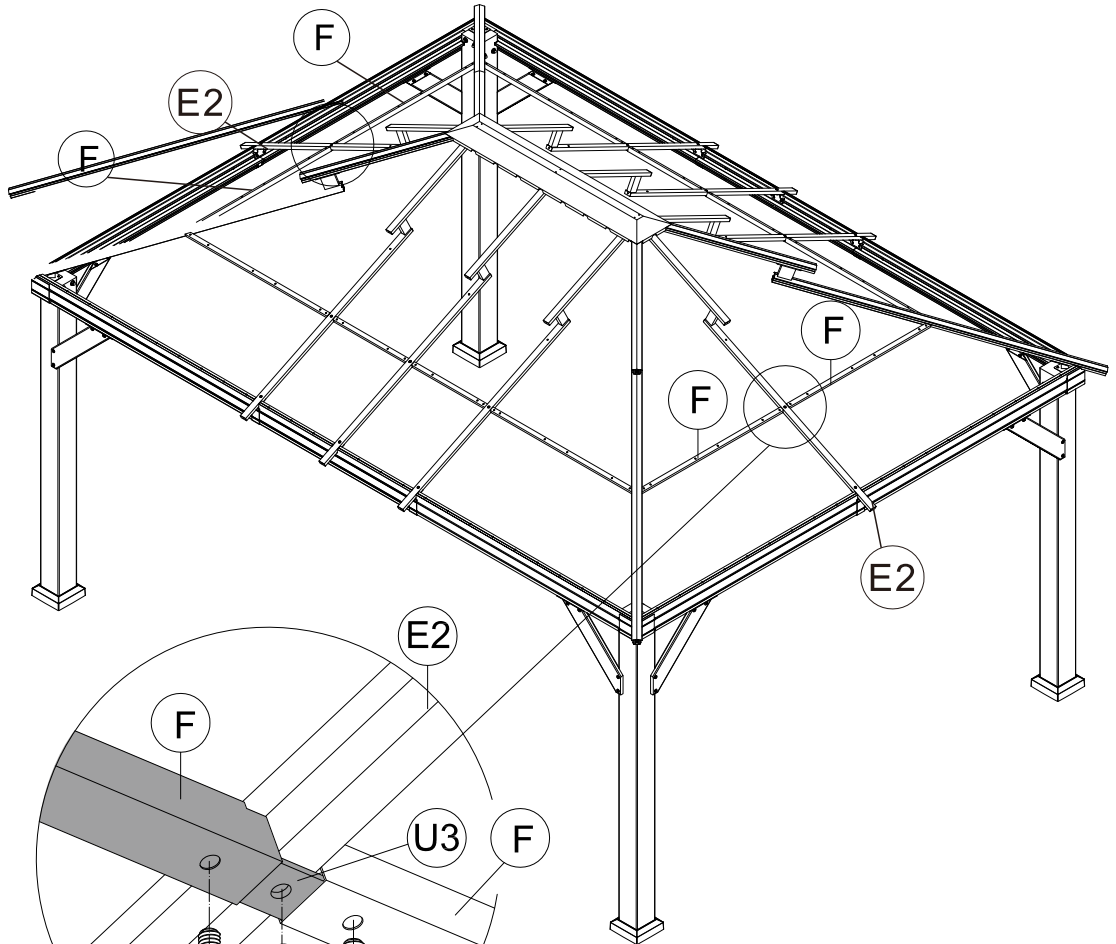

Inside View

(2) Attach 2 Part #F and Part #U3 to Part #E2 with Blot #7 and Blot #8.

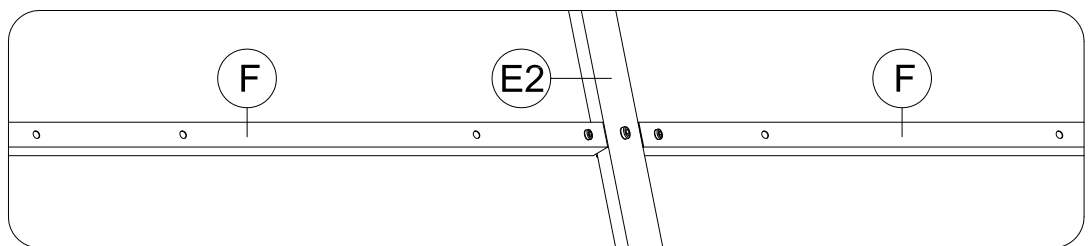

Outside View

(3) Repeat the above procedures to assemble the opposite side.



U2 4x

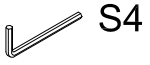

1 1x



M6x16

8 12x

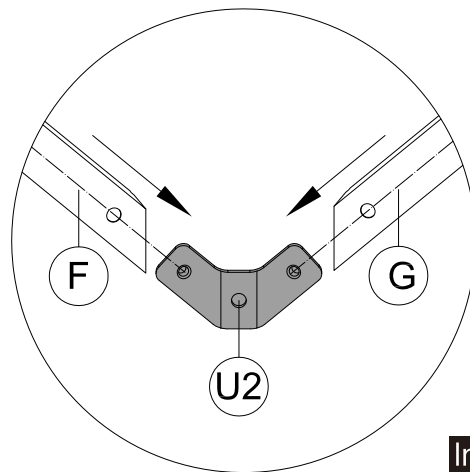
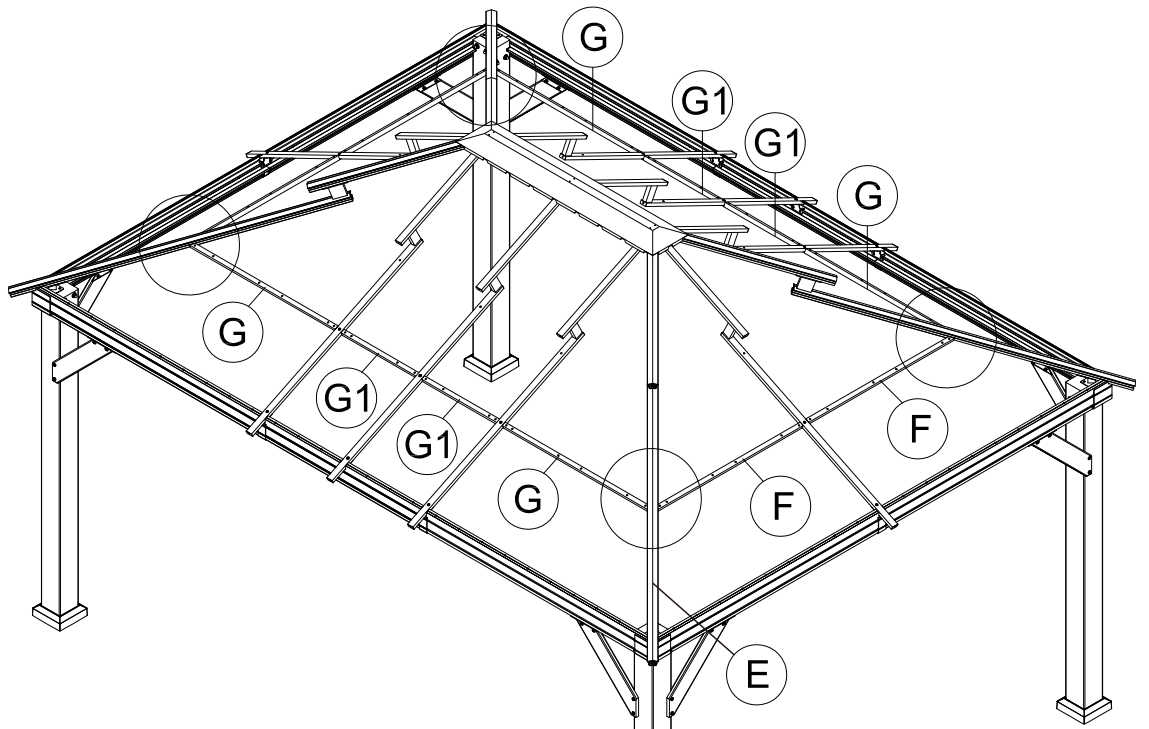

Inside View

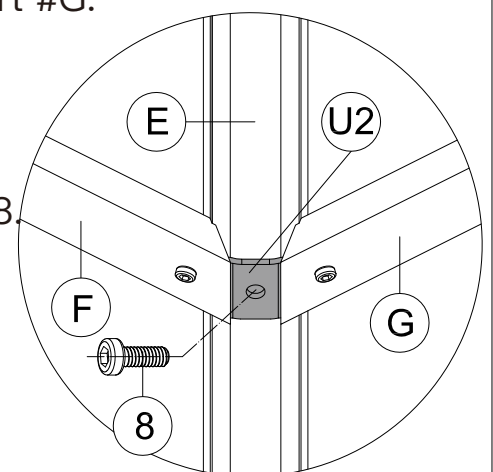
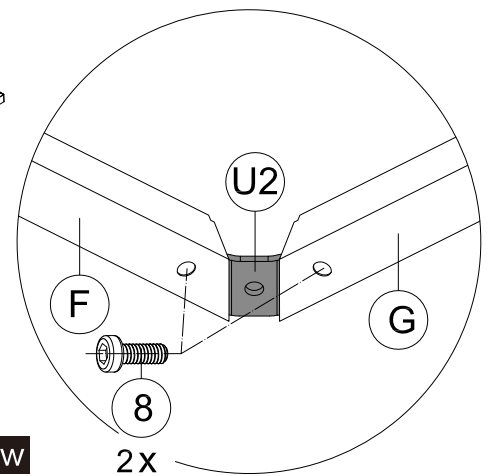

(1) Insert Part #U2 into Part #F and Part #G.

(2) Secure with 2 Bolts #8.

(3) Secure them to Part #E with Bolt #8.

(4) Repeat the above procedures to assemble the other 3 sides.

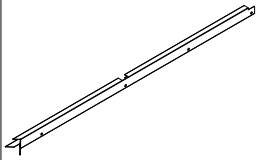

J1 2x

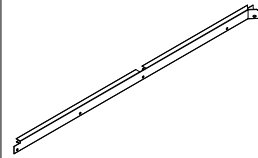

J2 2x

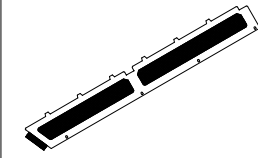

Q1 2x

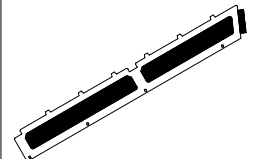

Q2 2x

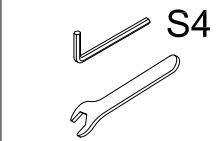

1 1x



5 8x



7 8x

26

(1) Connect Part #J1 and Part #Q1 with 2 Bolts #7 and 2 Nuts #5.

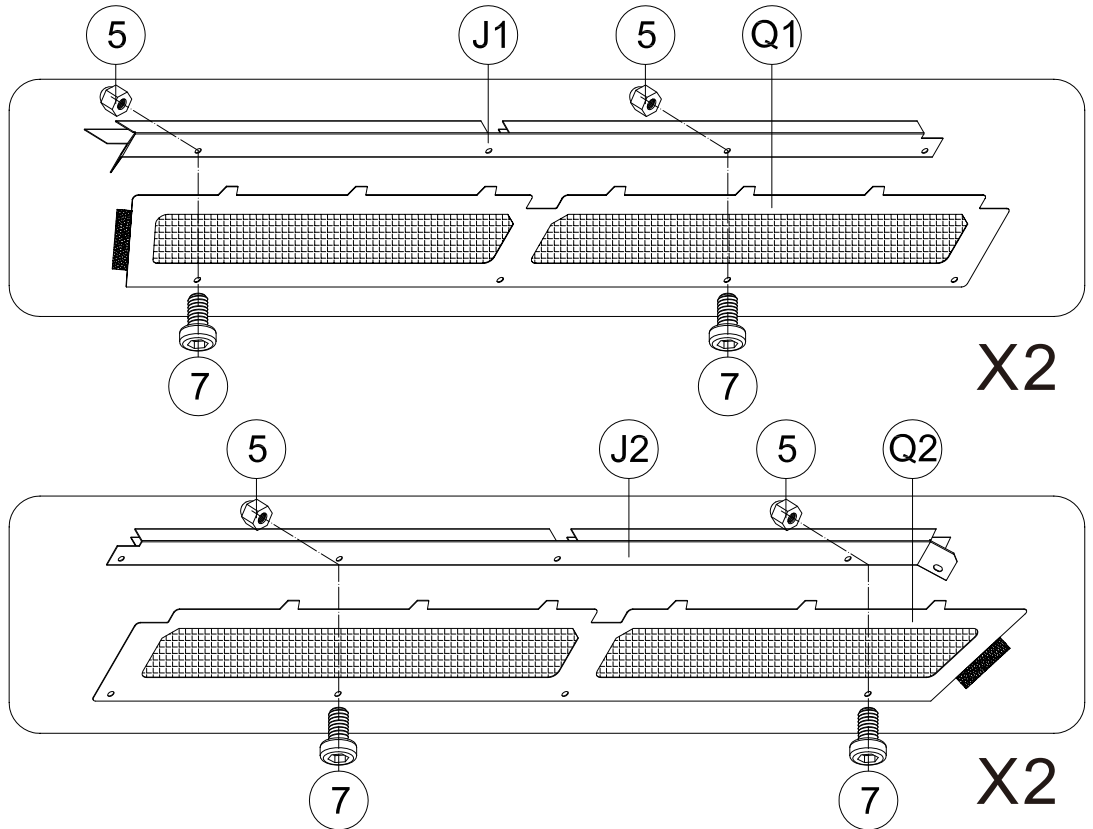

(2) Connect Part #J2 and Part #Q2 with 2 Bolts #7 and 2 Nuts #5.

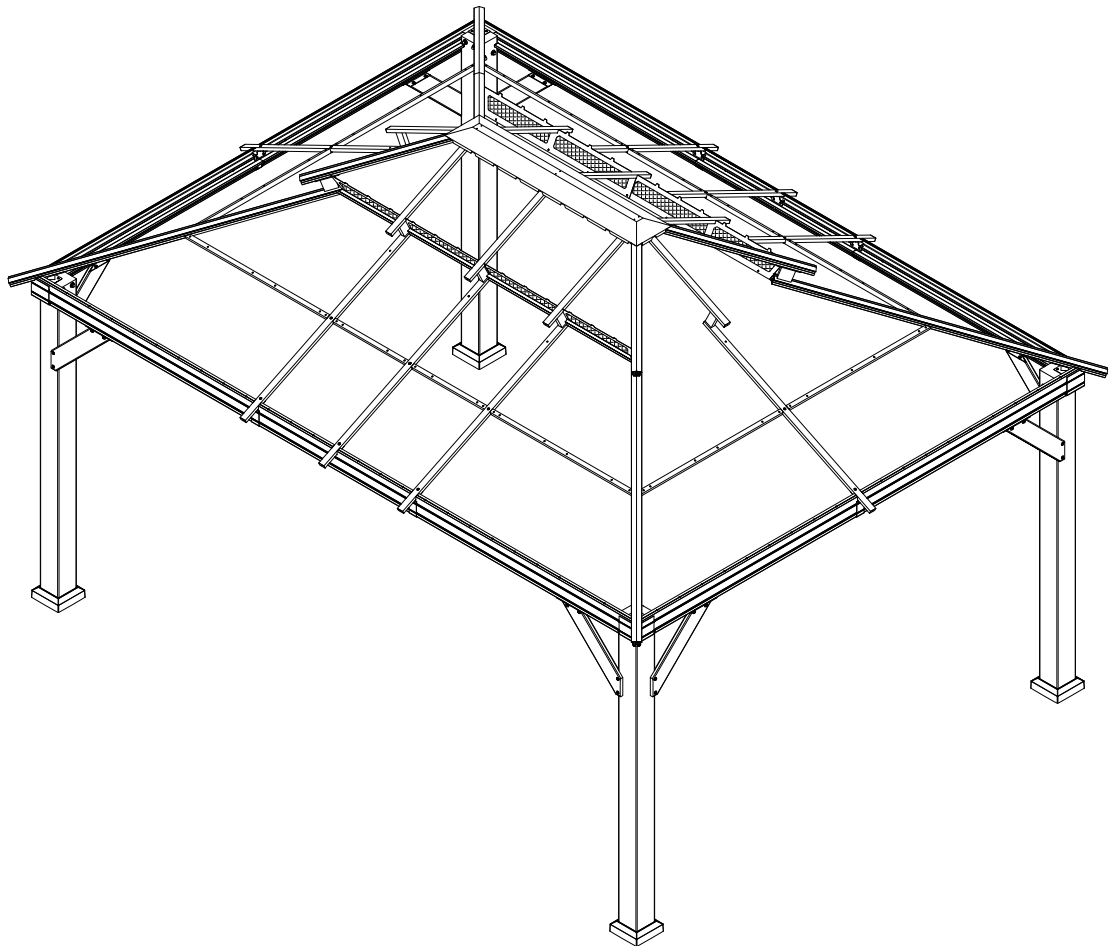

S4

1 1x



M6x16

8 6x

(1) Place the Assembled J1 & Q1 and J2 & Q2 on Part #E2, secure with 3 Bolts #8.

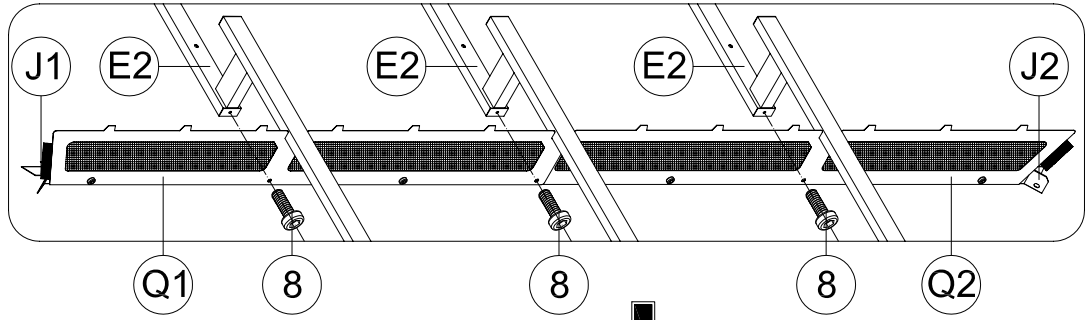

Inside View

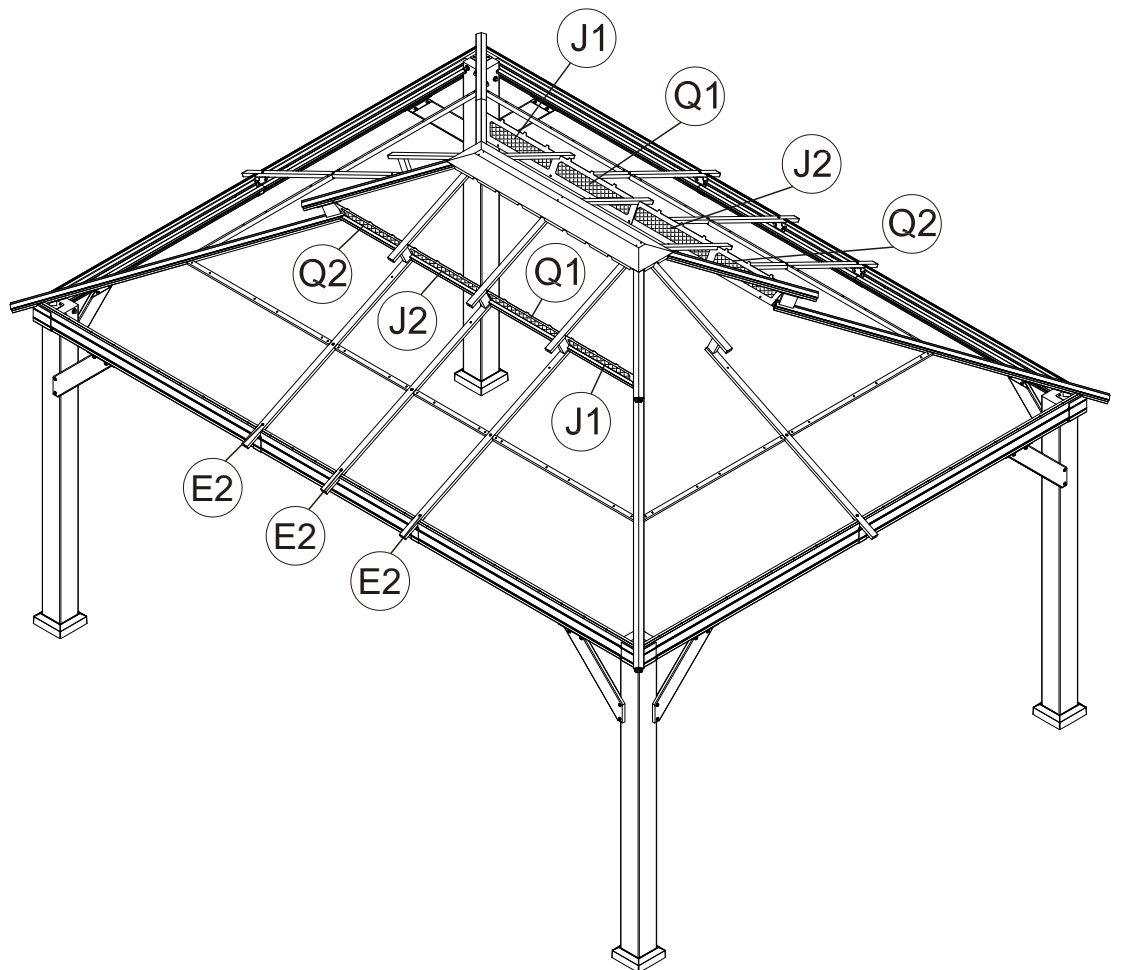
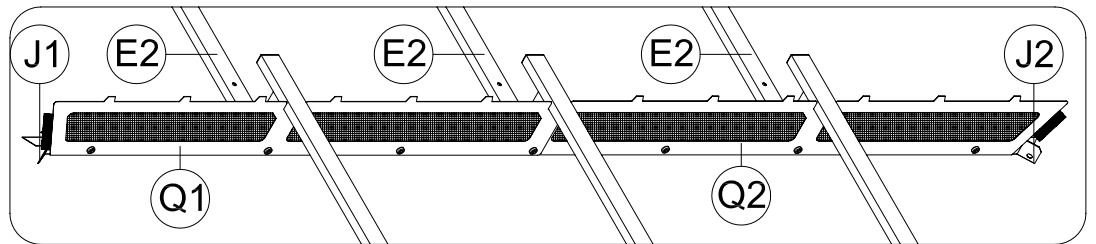

(2) Repeat the above procedures to assemble the opposite side.

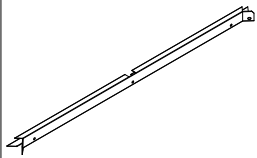

J 2x

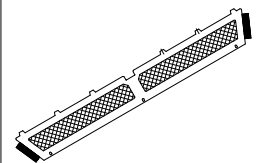

Q 2x



1 1x



M6

5 4x



M6x10

7 4x



M6x16

8 2x

(1) Connect Part #J and Part #Q with 2 Bolts #7 and 2 Nuts #5.

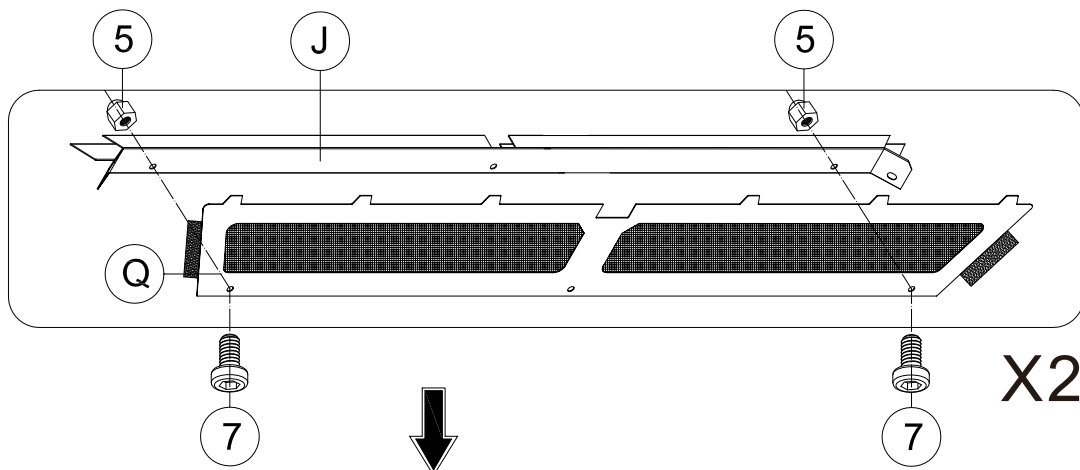

(2) Place the Assembled Part #J & #Q on Part #E2, securing with 1 Bolt #8.

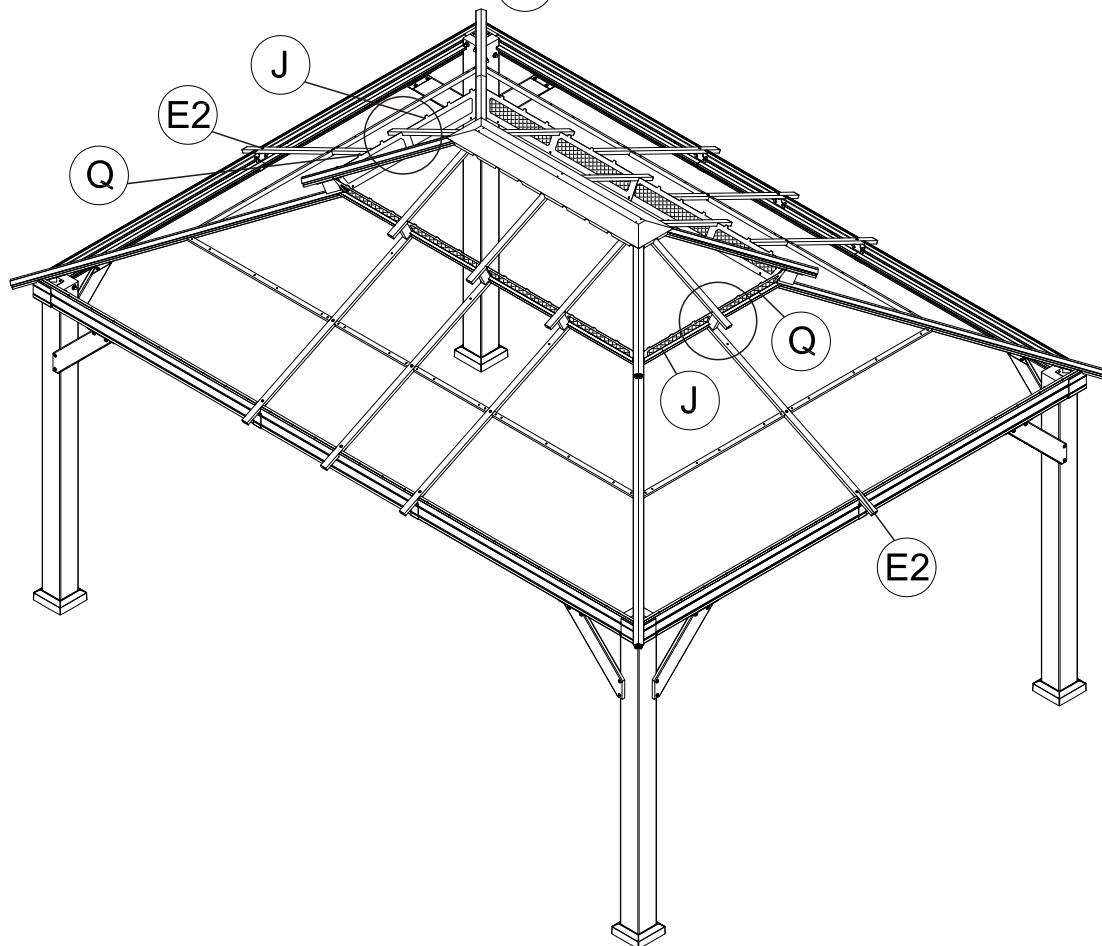
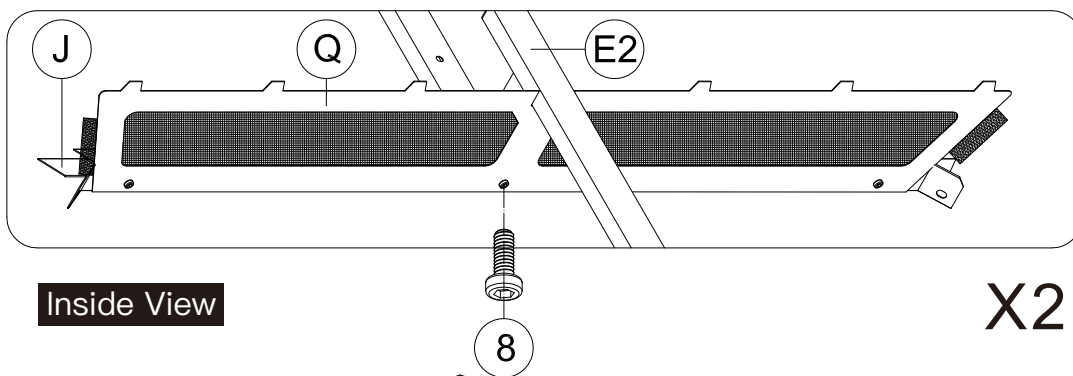

(3) Repeat the above procedures to assemble the opposite side.



X3 4x



ST6.3x15

2 4x

(1) Place Part #J and Part #J1/J2 on Part #E;
put on Part #X3 and secure with Self-tapping Screw #2.

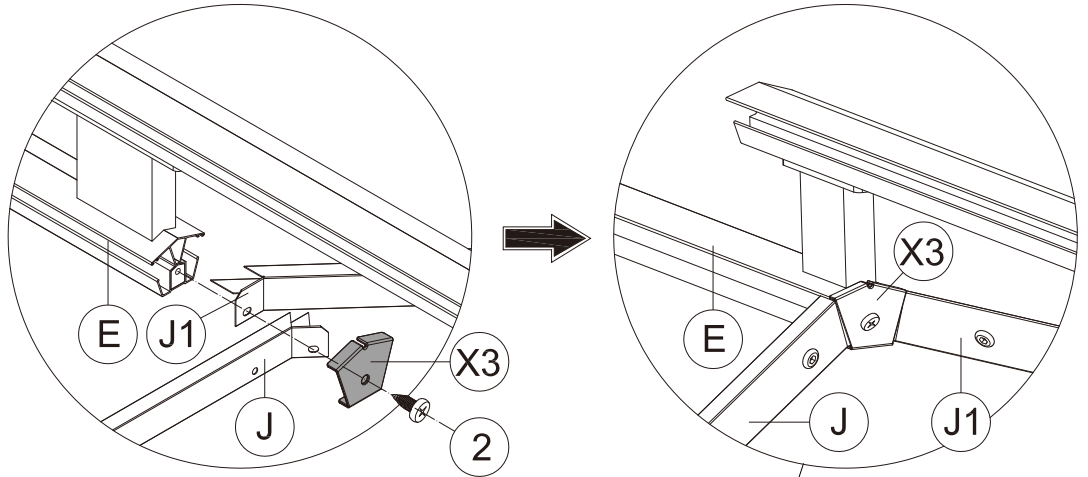

Inside View

Inside View

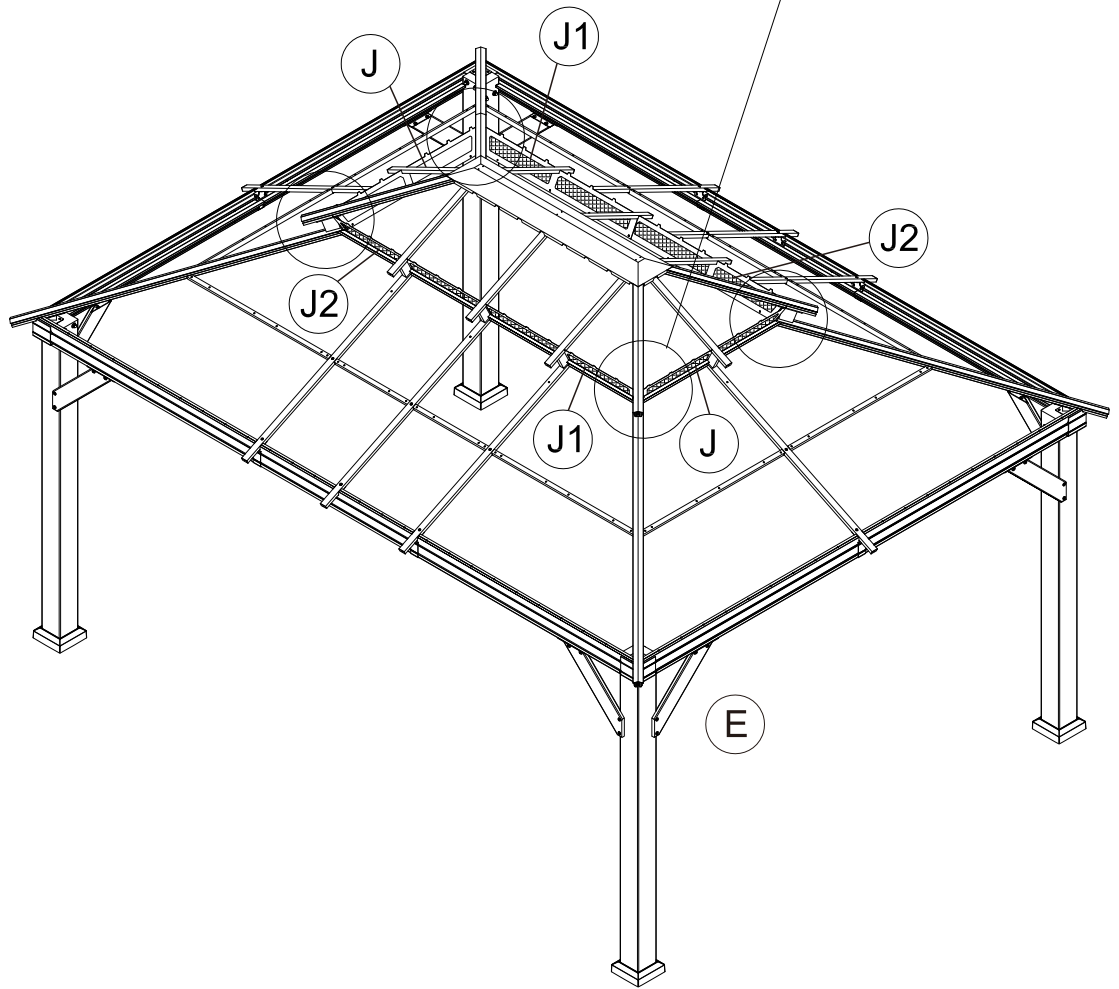

(2) Repeat the above procedures to assemble the other 3 corners.

Cover Part #Z, #Z1 & #Z2 to Roof Panels.



(L1) 2x

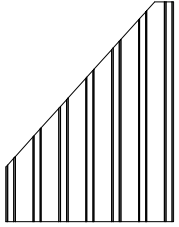

(L2) 2x

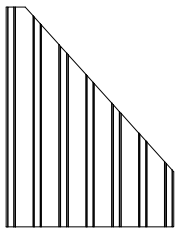

(L3) 2x



(L4) 2x

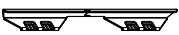

(Z) 8x



(Z1) 4x



(Z2) 4x

30

X2

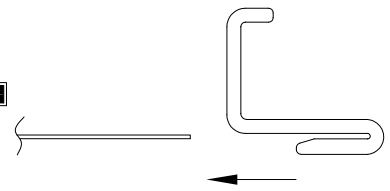
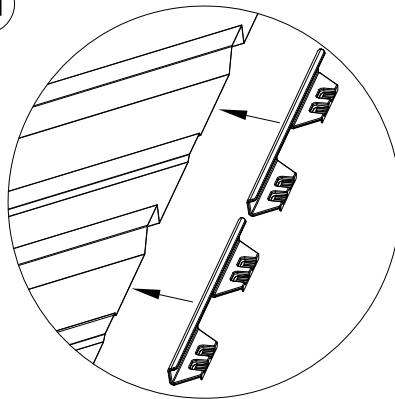
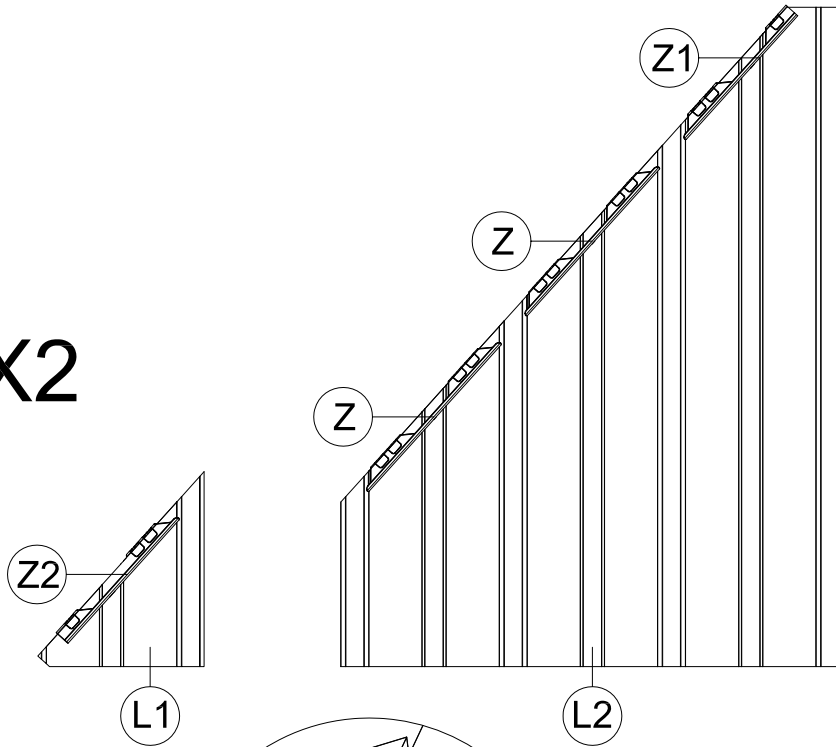

Section View

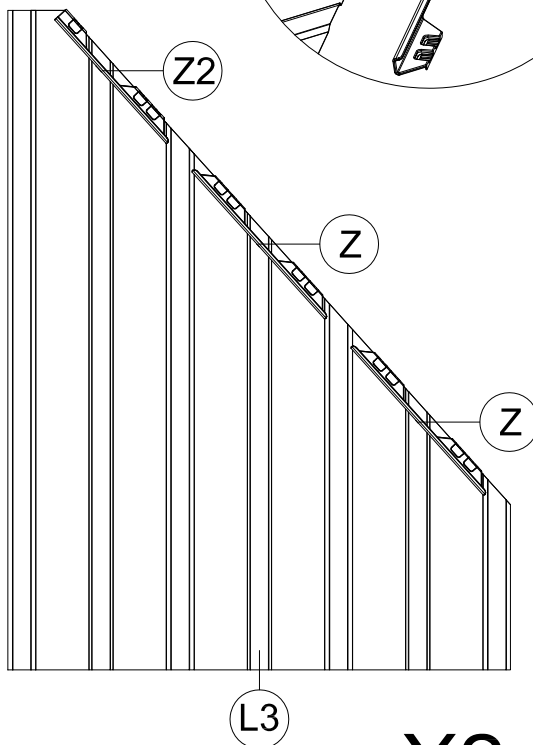

X2

Cover Part #Z to Roof Panels.

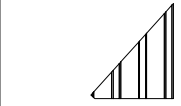

N1 2x

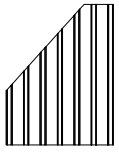

N2 2x

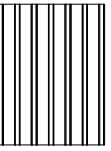

N3 4x

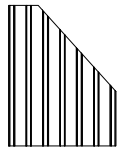

N4 2x

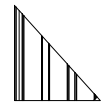

N5 2x

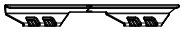

Z 12x

X2

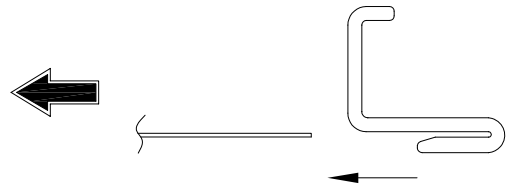
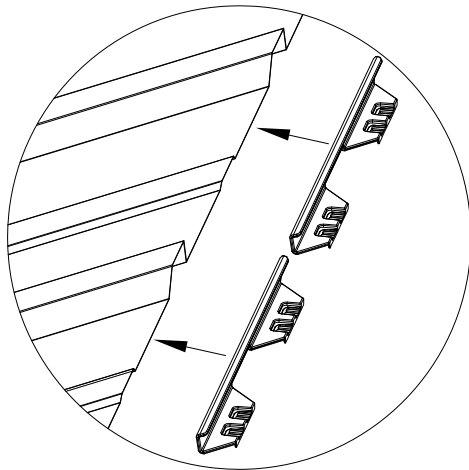
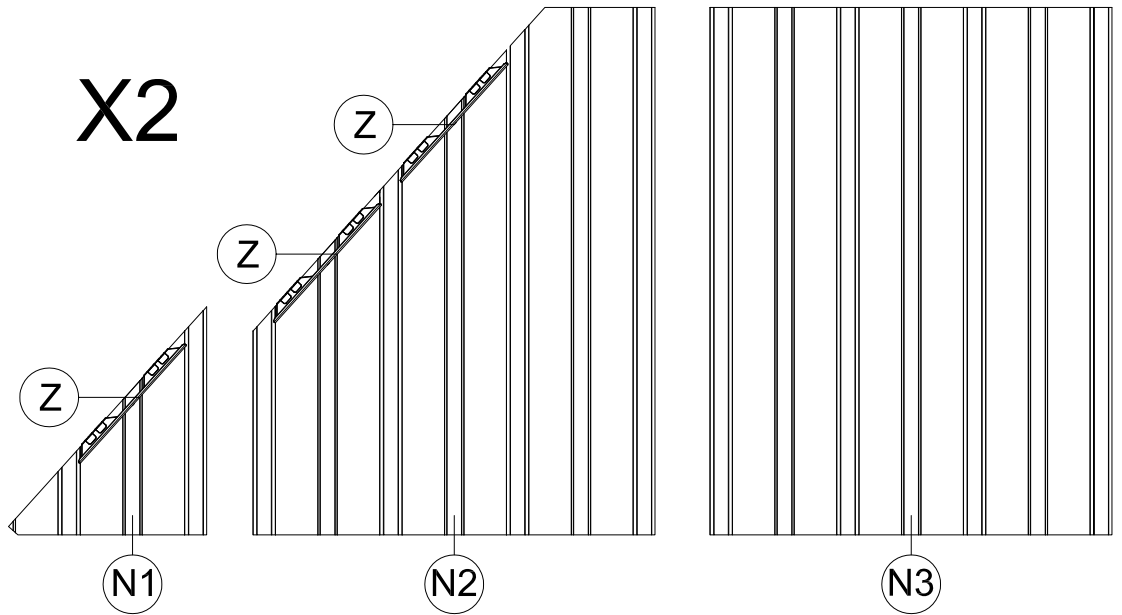

Section View

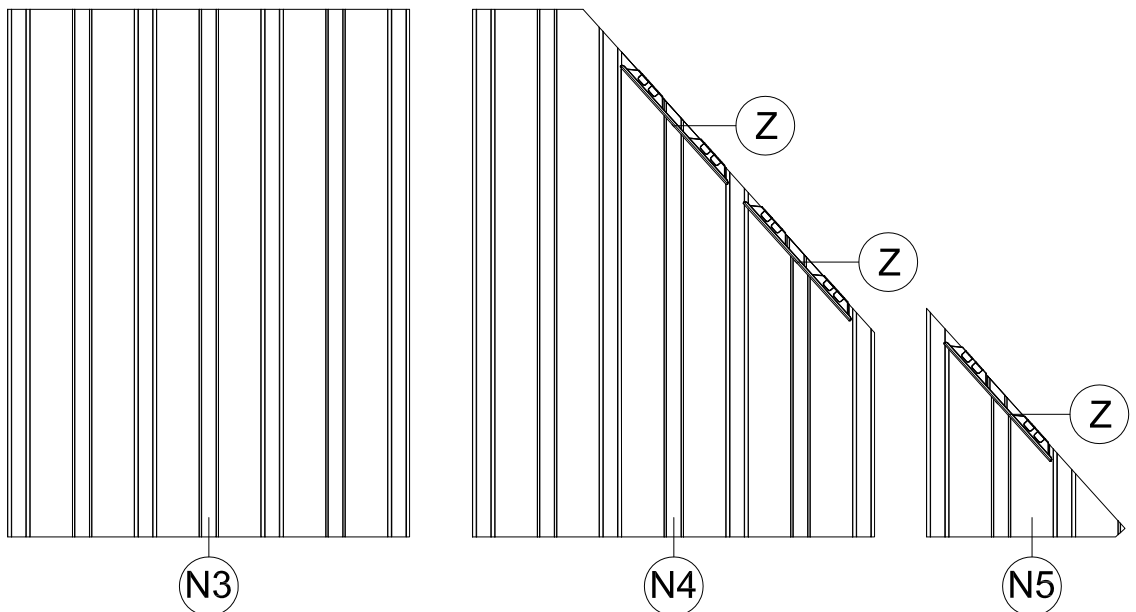

X2

ATTENTION: The bigger roof panel need to cover the smaller one.

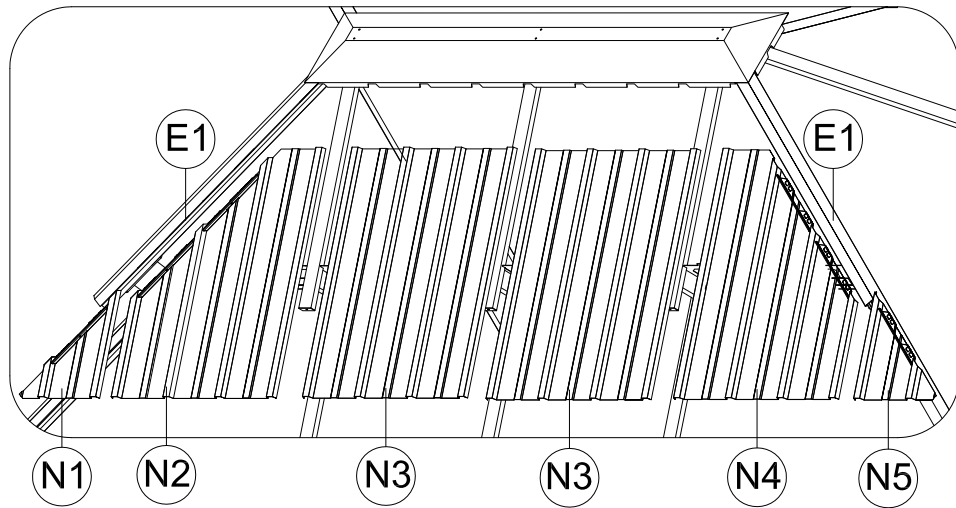

▲ If you can't install N2, N3 or N4, push the outside roof cover up and try to insert them again.

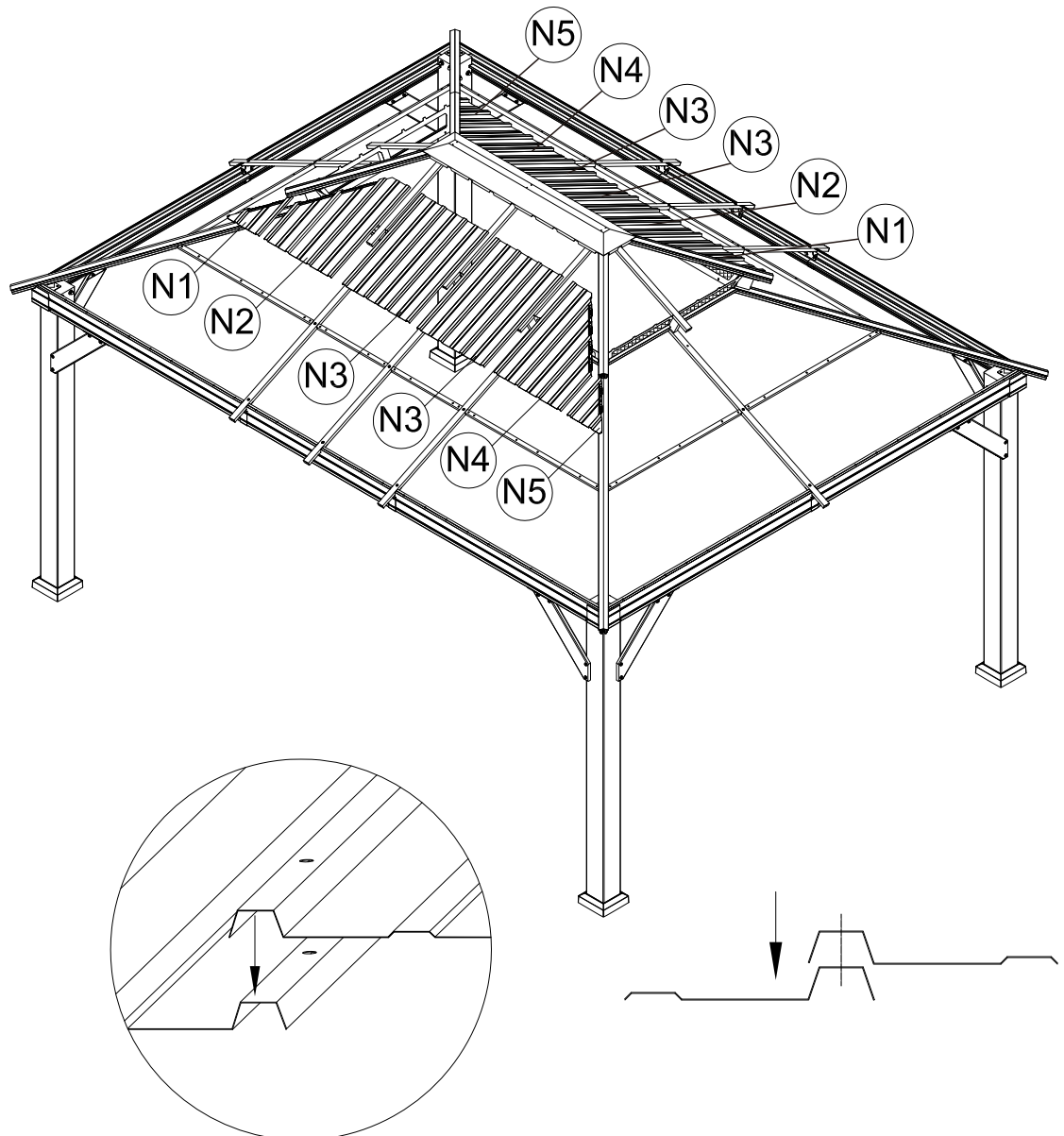

(1) Insert Part #N1, N2,N3*2,N4,N5 into the frame.

(2) Repeat the above procedures to assemble the opposite side.

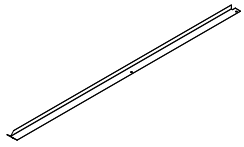

H1 2x

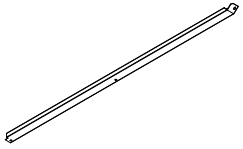

H2 2x



X2 2x



1 1x



M6x16

8 6x

(1) Place Part #H1 and Part #H2 on Part #E2, and secure with 2 Bolt #8.

(2) put on Part #X2 and secure with Bolt #8.

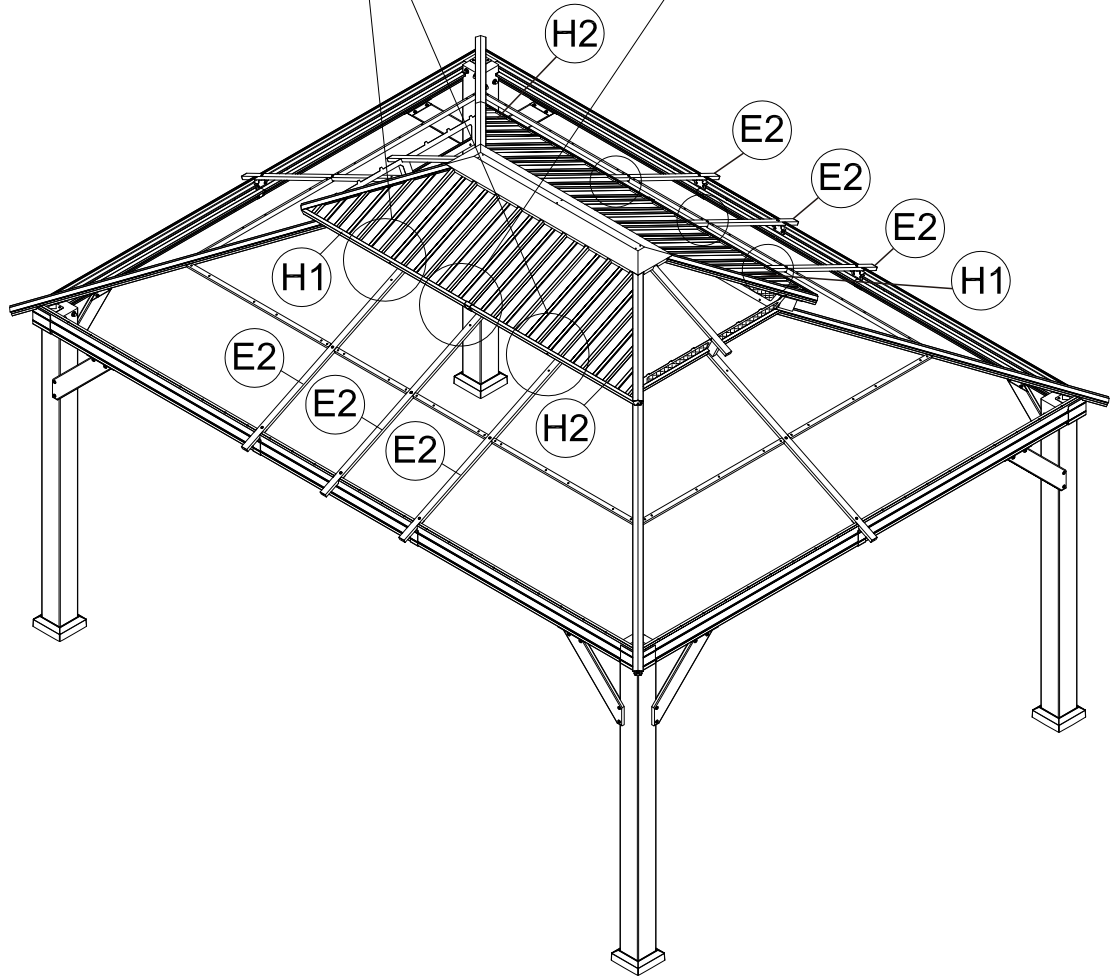
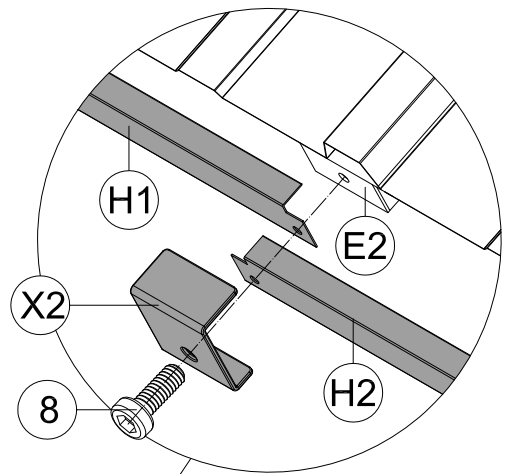
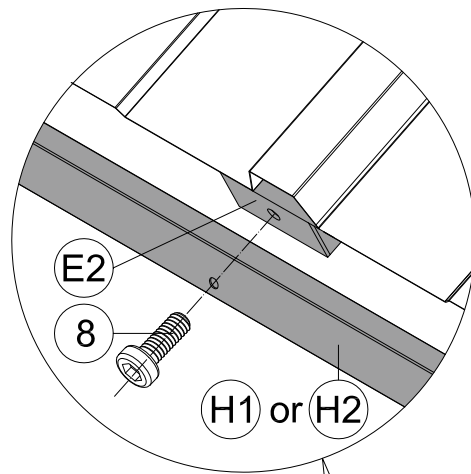

(3) Repeat the above procedures to assemble the opposite side.

ATTENTION: The bigger roof panel need to cover the smaller one.

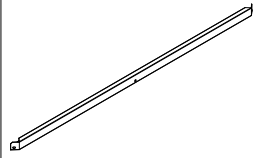

H 2x

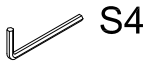

1 1x



M6x16

8 2x

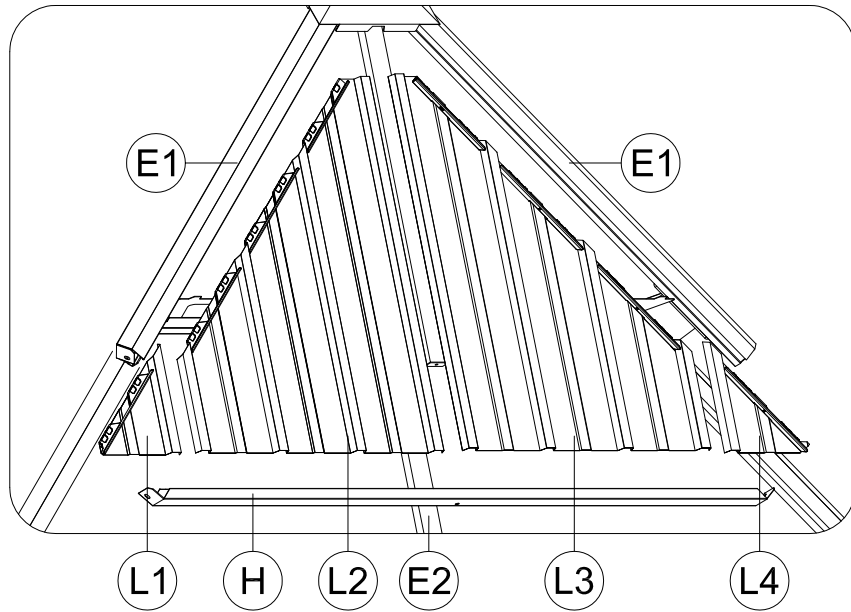

(1) Insert Part #L1 and Part #L2 into the frame.

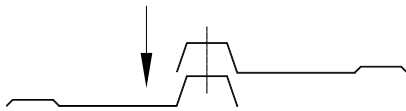

(2) Insert Part #L4 and Part #L3 into the frame.

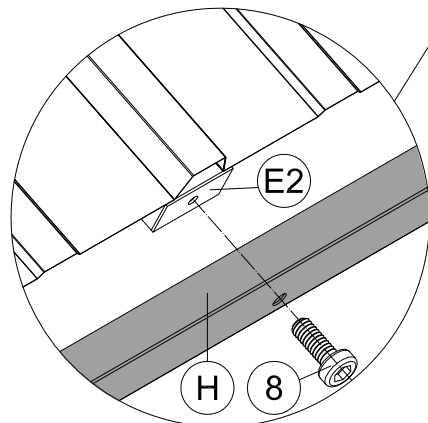
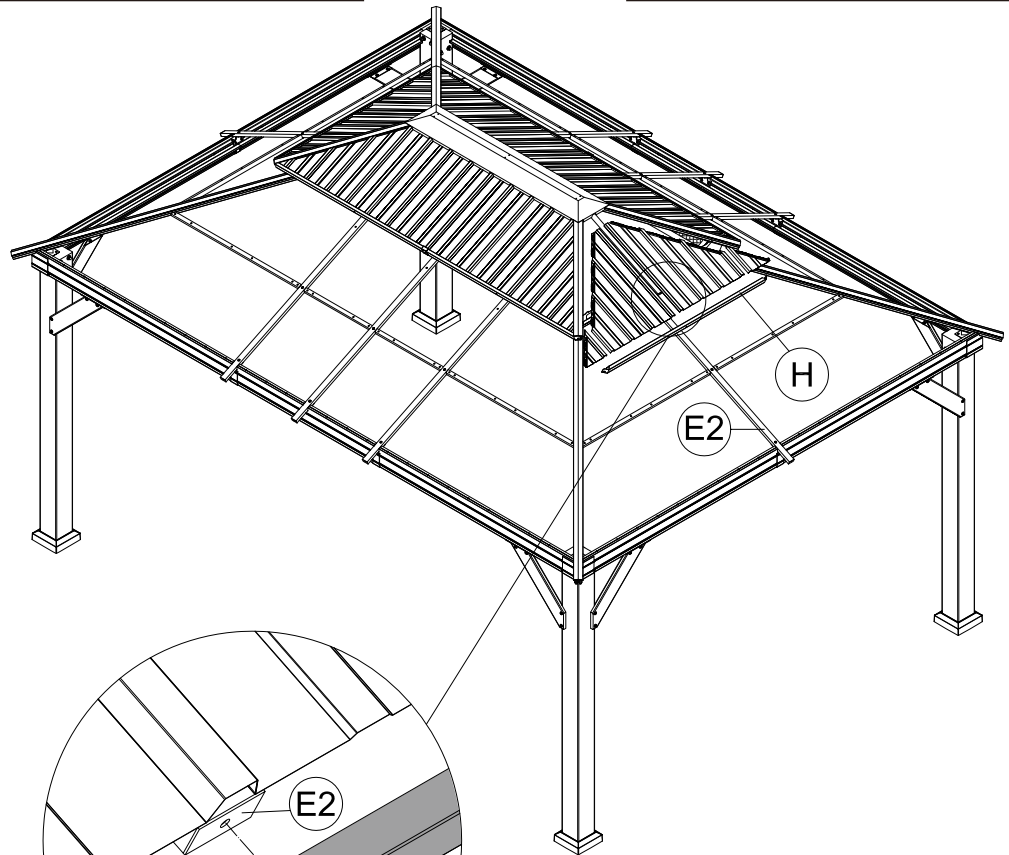
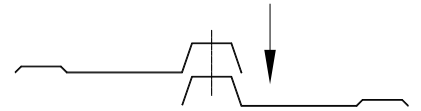

(3) Attach Part #H to Part #E2, securing with Bolt #8.

(4) Repeat the above procedures to assemble the opposite side.



X3 4x



ST6.3x15

2 4x

(1) Place Part #H and Part #H2 on Part #E1;
put on Part #X3 and secure with Self-tapping Screw #2

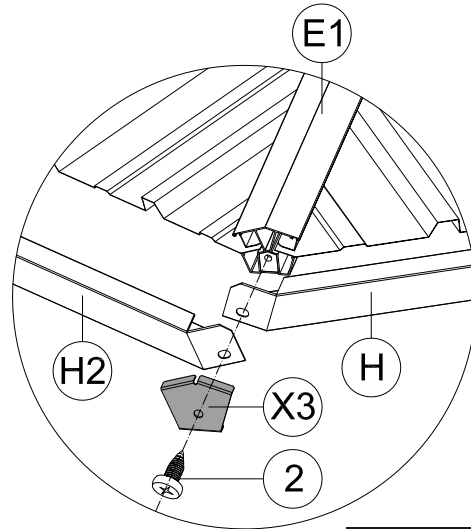

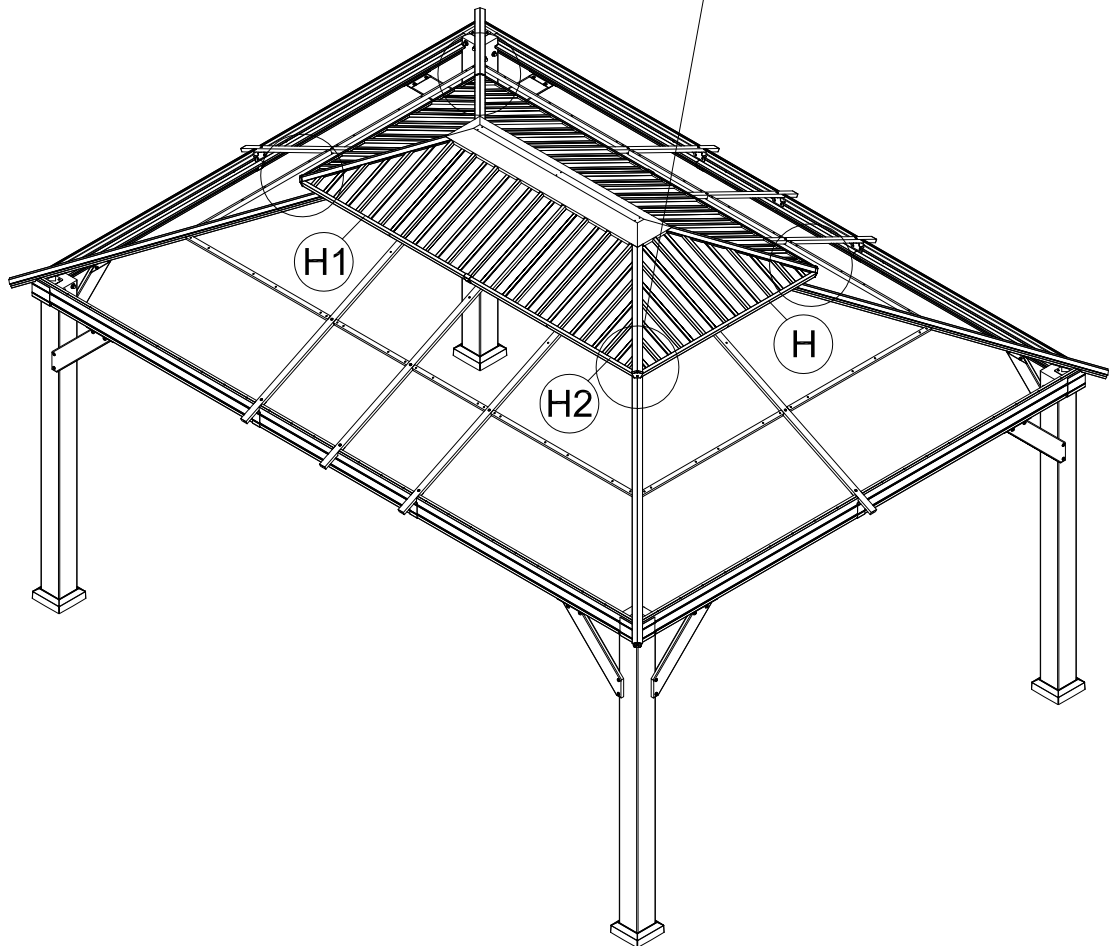

Outside View

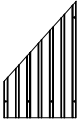
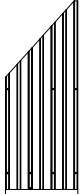
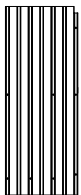
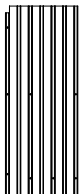
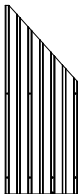
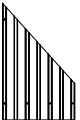

(2) Repeat the above procedures to assemble the other 3 corners.

Cover Part #Z to Roof Panels

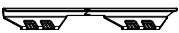
-  (M1) 2x
-  (M2) 2x
-  (M3) 2x
-  (M4) 2x
-  (M5) 2x
-  (M6) 2x
-  (M7) 2x
-  (M8) 2x
-  (Z) 28x

36

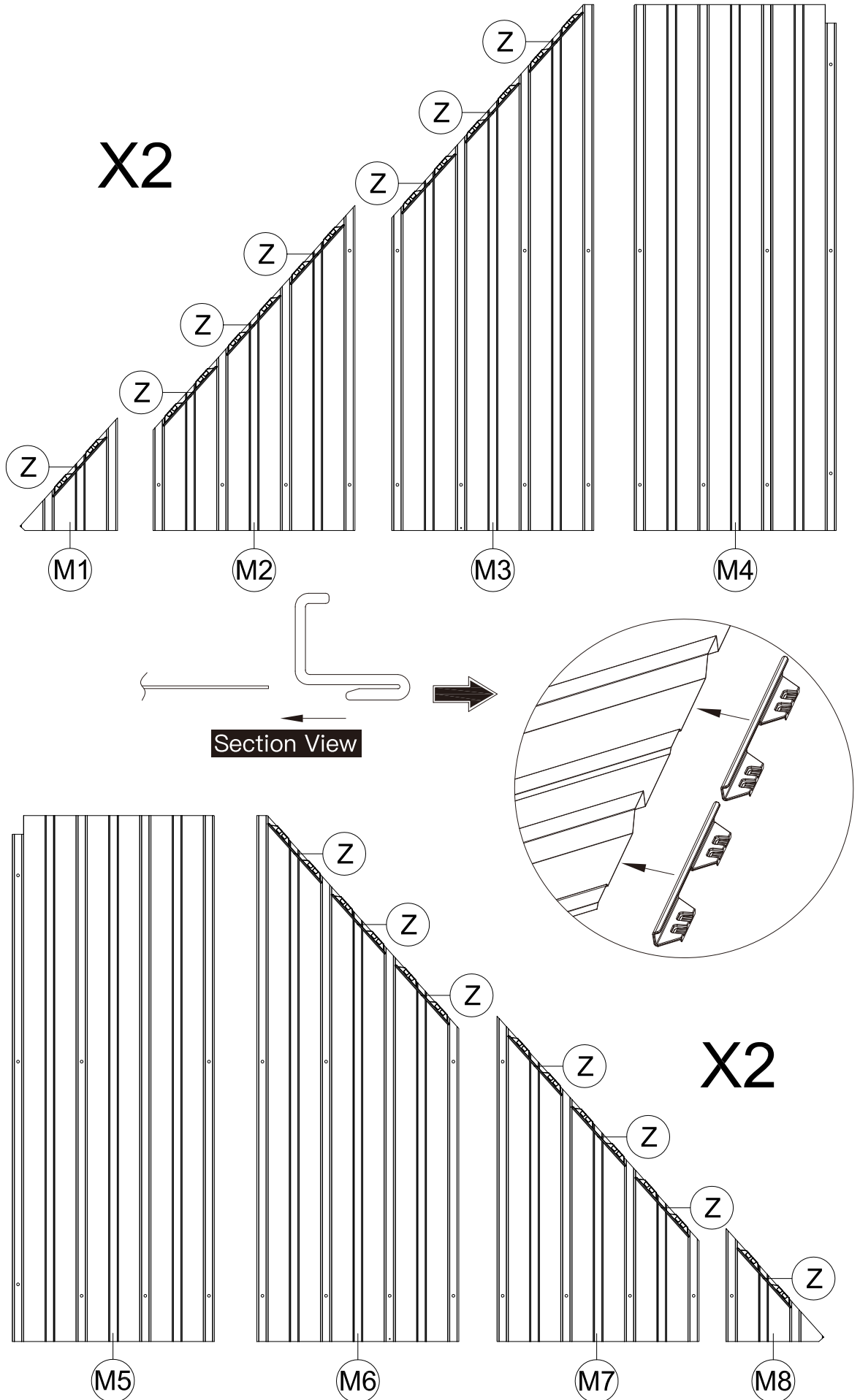

Cover Part #Z to Roof Panels



P1 2x

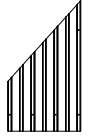

P2 2x

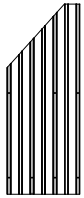

P3 2x

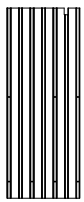

P4 2x

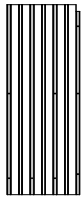

P5 2x



Z 14x

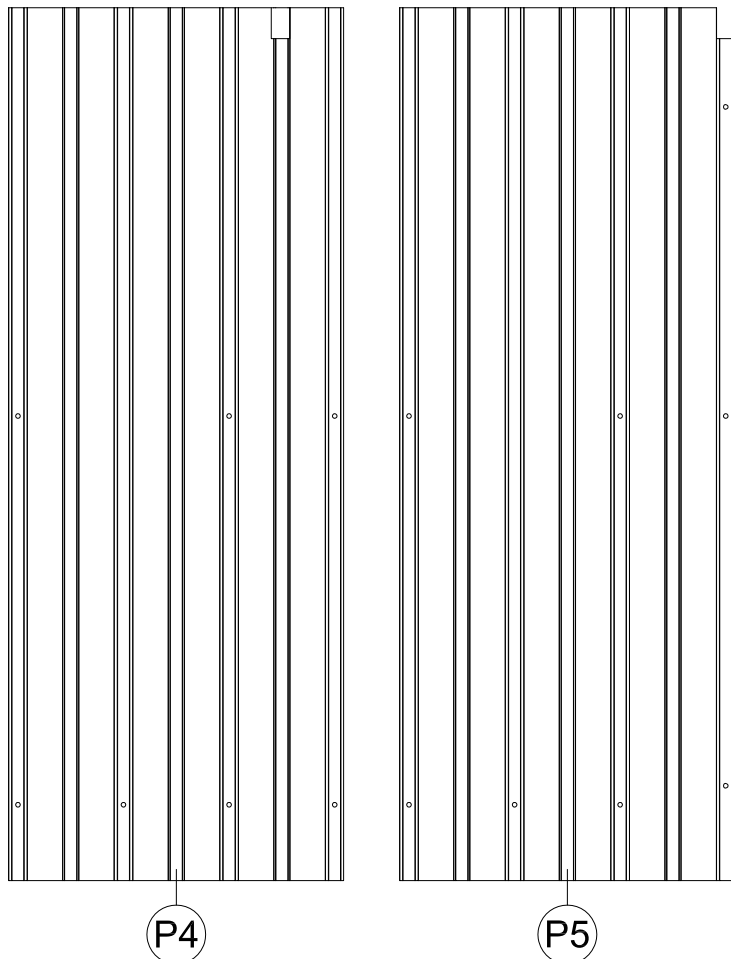
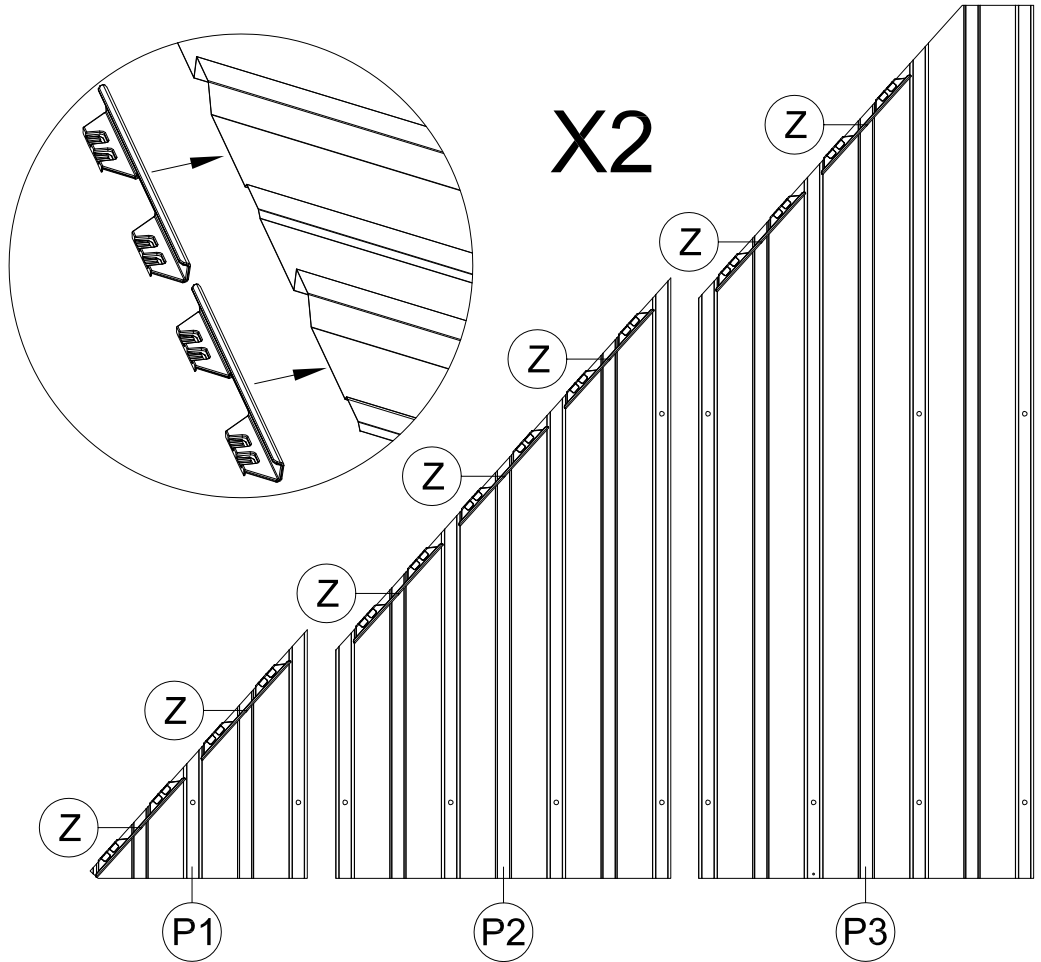

Cover Part #Z to Roof Panels

P6 2x

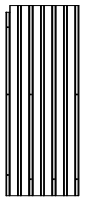

P7 2x

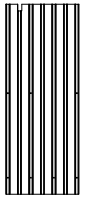

P8 2x

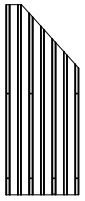

P9 2x

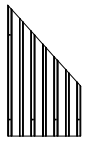

P10 2x



Z 14x

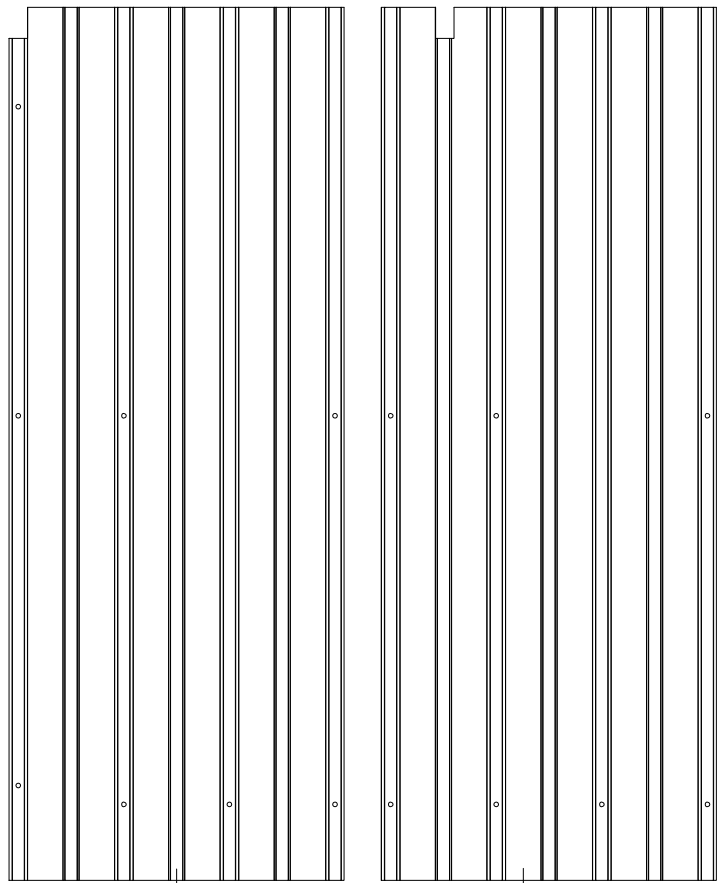

P6

P7

X2

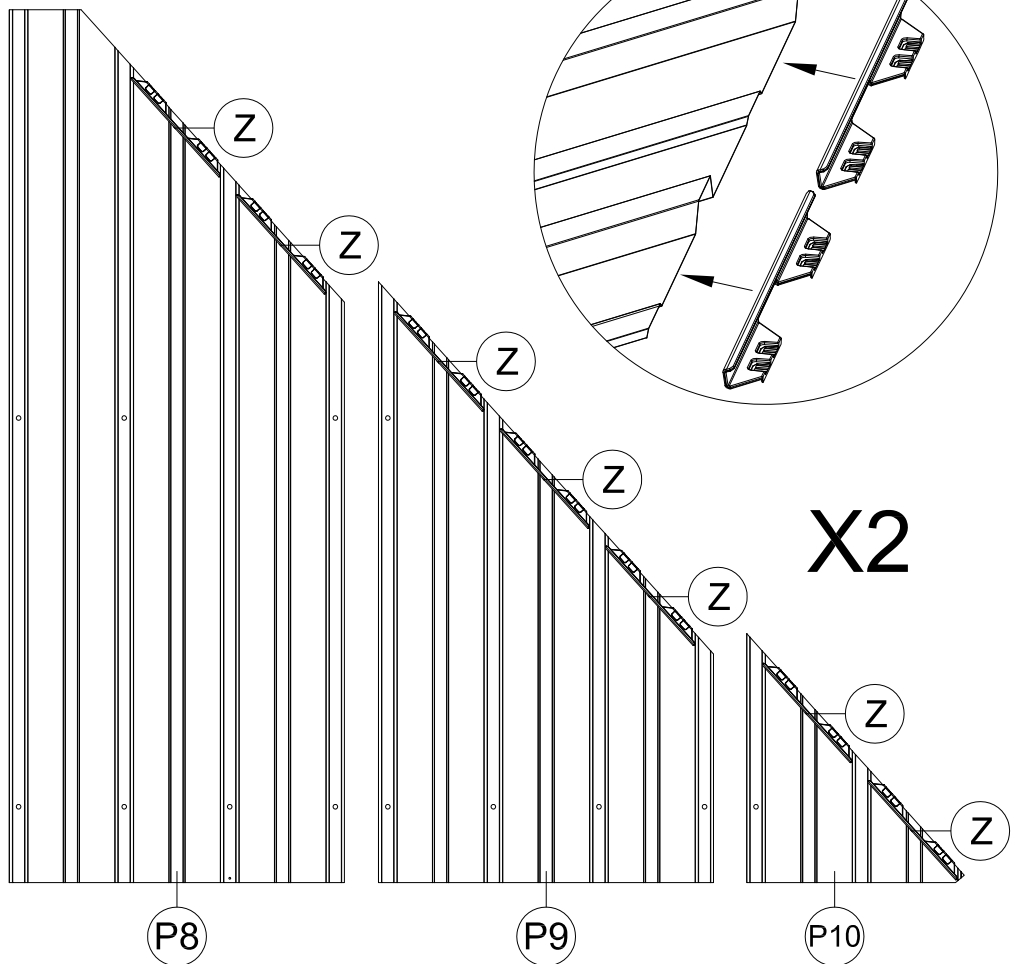

Z

Z

Z

Z

Z

Z

Z

P8

P9

P10

X2

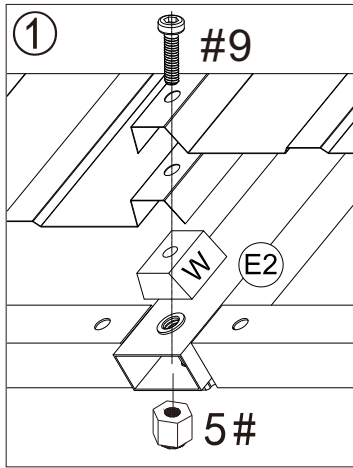

▲ Part #W should be inserted between roof panels and solidifying bar or beams, then secure with bolts and nuts.

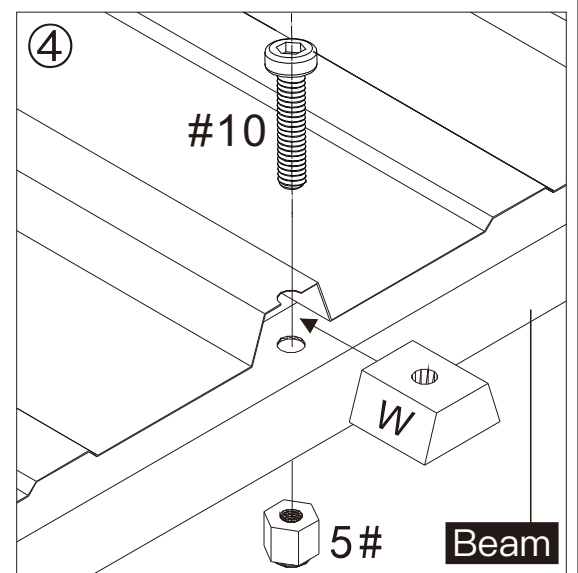
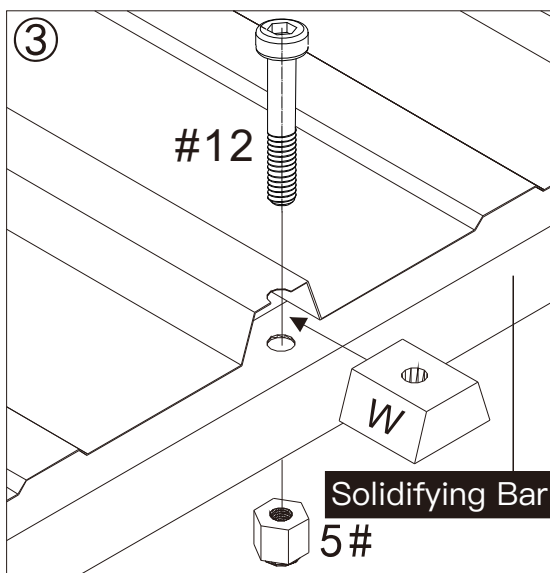
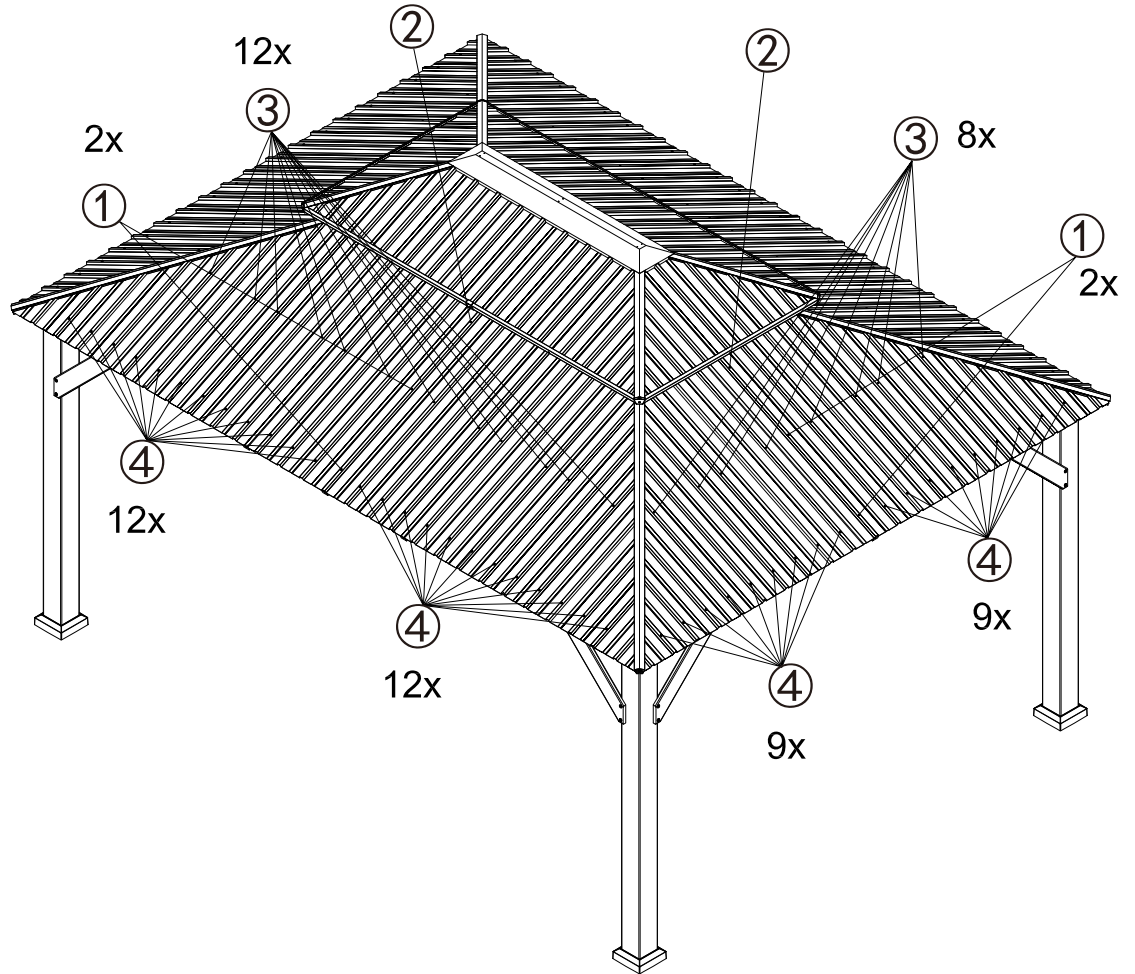
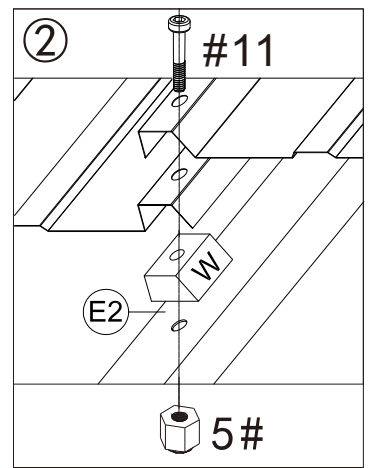

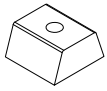

W 12x



1 1x



M6

5 12x



M6x28

10 12x

ATTENTION: The bigger roof panel need to cover the smaller one.

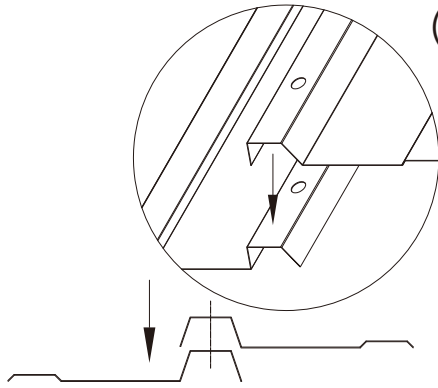

(1) Insert Part #P1, Part #P2 into the frame.

(2) Place 3 Part #W between roof panels and beams. Then secure with 3 Bolts #10 and 3 Nuts #5.

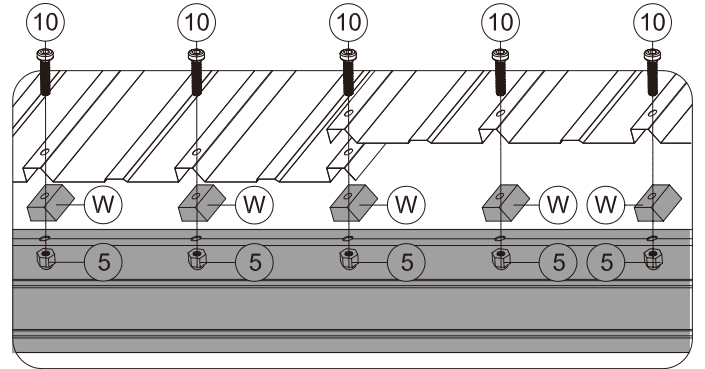

Beam

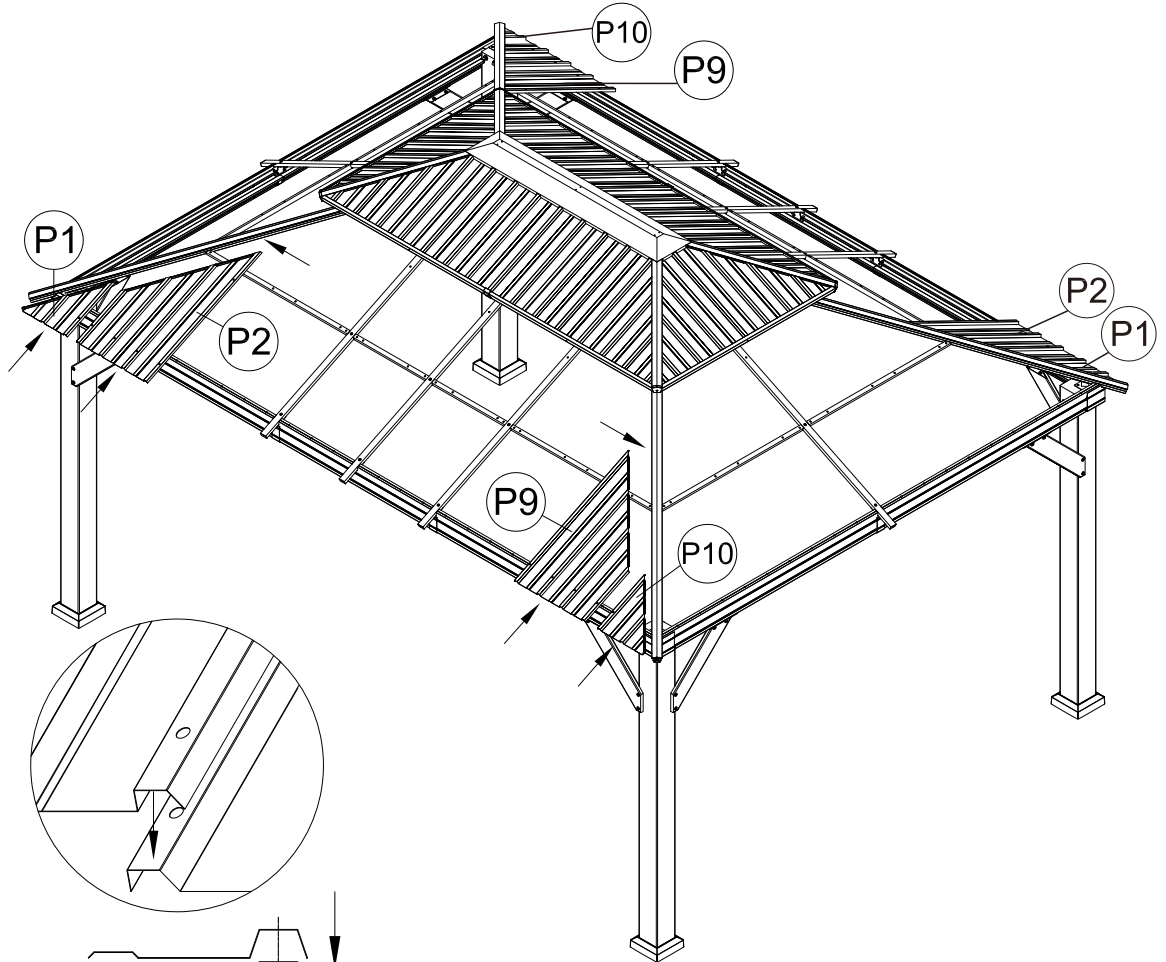

(3) Insert Part #P10, Part #P9 into the frame.

(4) Place 3 Part #W between roof panels and beams. Then secure with 3 Bolts #10 and 3 Nuts #5.

Beam

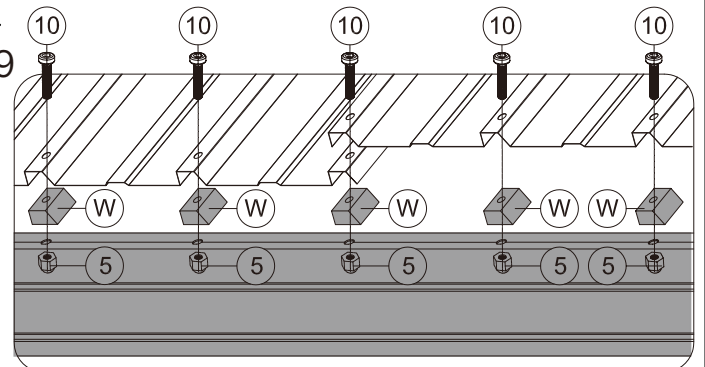

(5) Repeat the above procedures to assemble the opposite side.

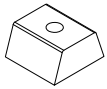

W 20x

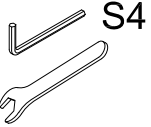

1 1x



M6

5 20x



M6x28

10 12x

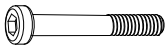

M6x50

12 8x

ATTENTION: The bigger roof panel need to cover the smaller one.

(1) Insert Part #P3 into the frame.

(2) Place 2 Part #W between roof panels #P3 and solidifying bars. Then secure with 2 Bolt #12 and 2 Nuts #5.

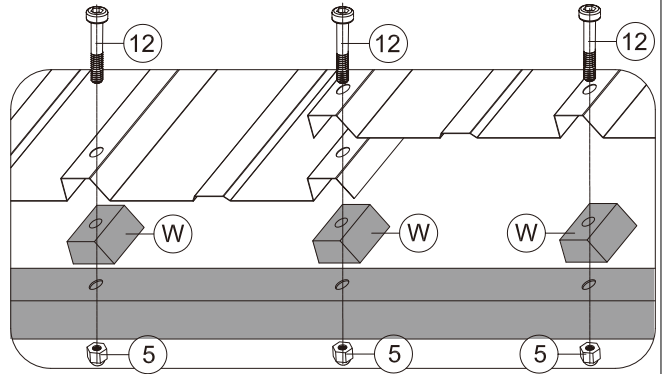

Solidifying Bar

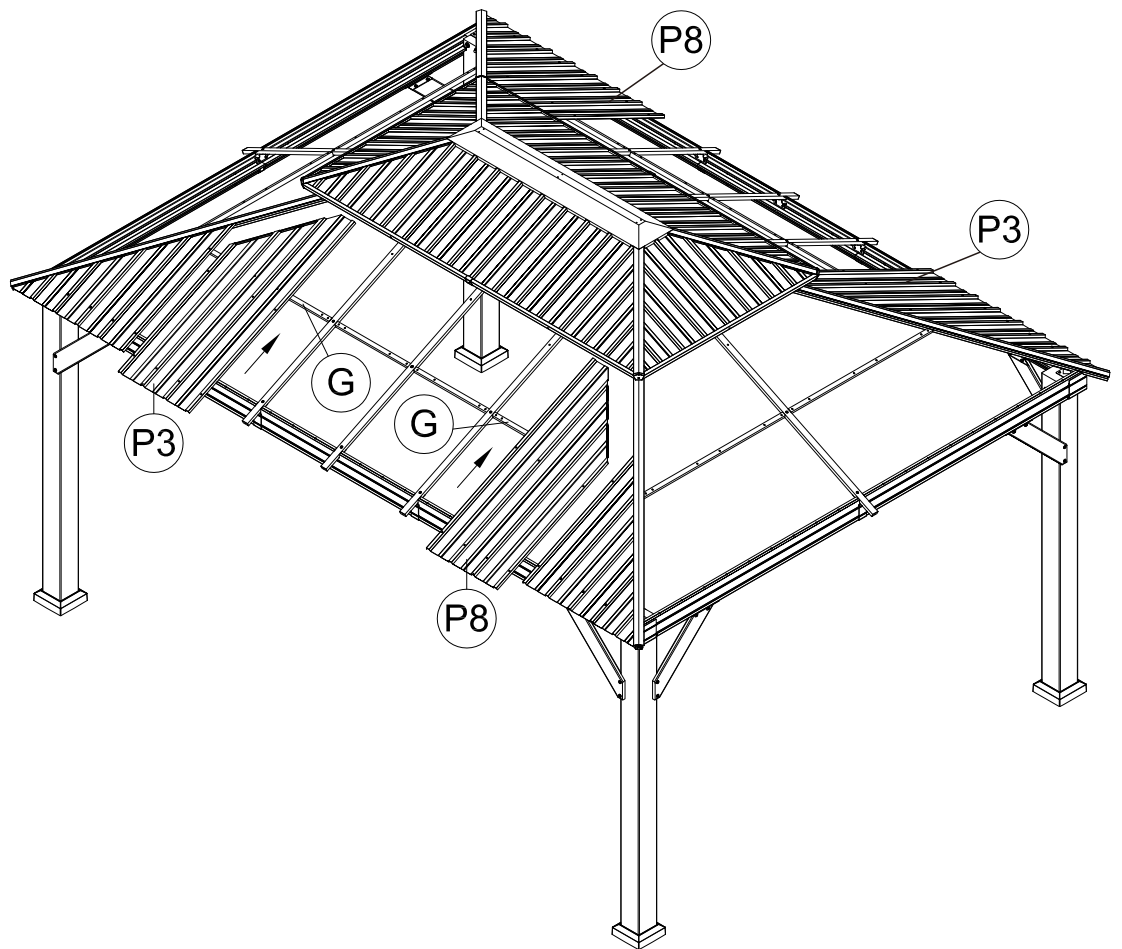

(3) Place 3 Part #W between roof panels #P3 and beams. Then secure with 3 Bolts #10 and 3 Nuts #5.

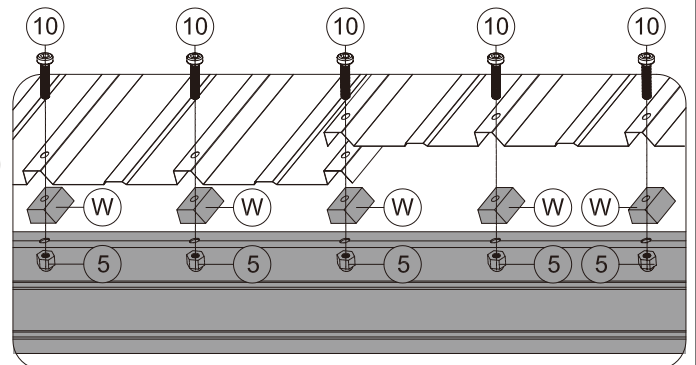

Beam

(4) Repeat the above procedures to assemble roof panel #P8 and the opposite side.

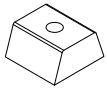

(W) 20x



(1) 1x



M6

(5) 20x



M6x28

(10) 12x

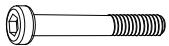

M6x50

(12) 8x

ATTENTION: The bigger roof panel need to cover the smaller one.

(1) Insert Part #P4 into the frame.

(2) Place 2 Part #W between roof panels #P4 and solidifying bars. Then secure with 2 Bolt #12 and 2 Nuts #5.

Solidifying Bar

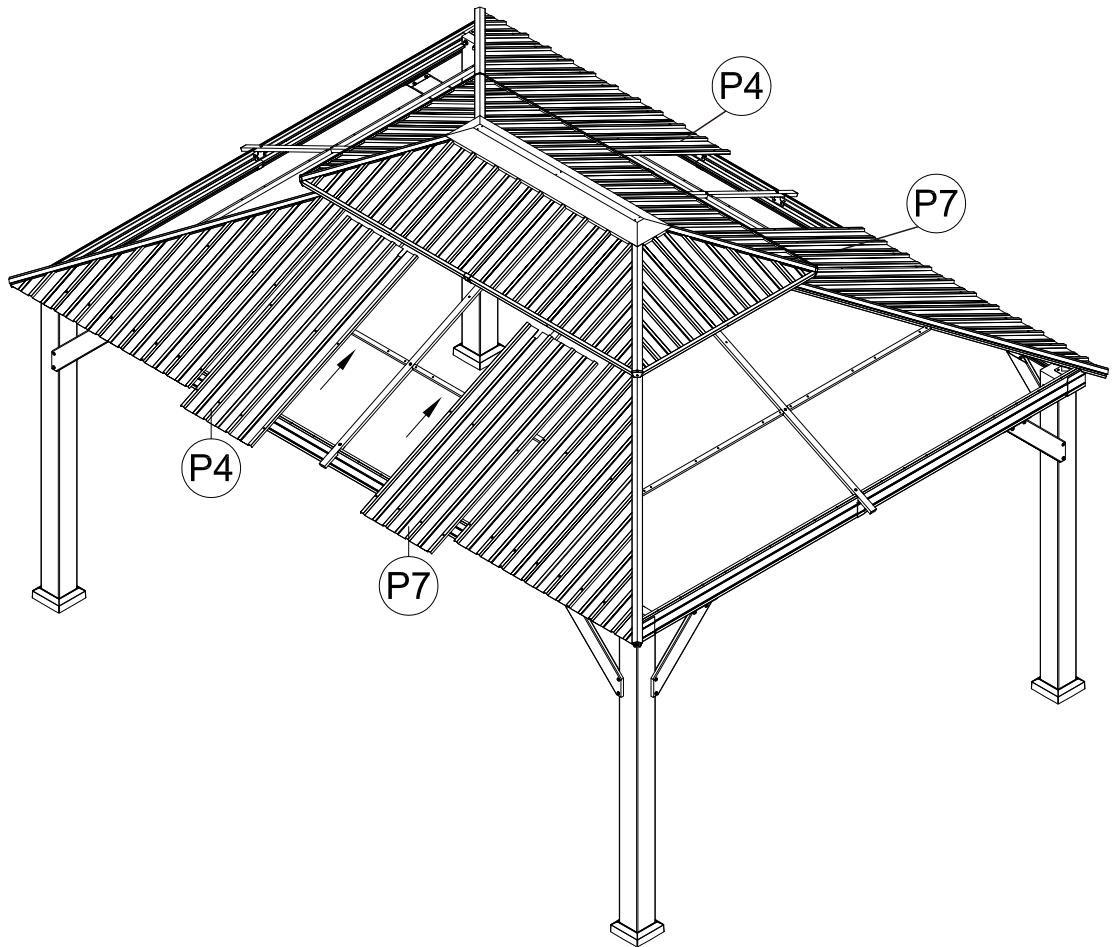
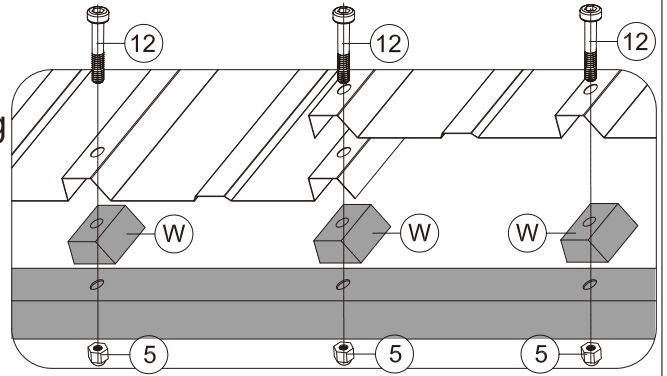

(3) Place 3 Part #W between roof panels #P4 and beams. Then secure with 3 Bolts #10 and 3 Nuts #5.

Beam

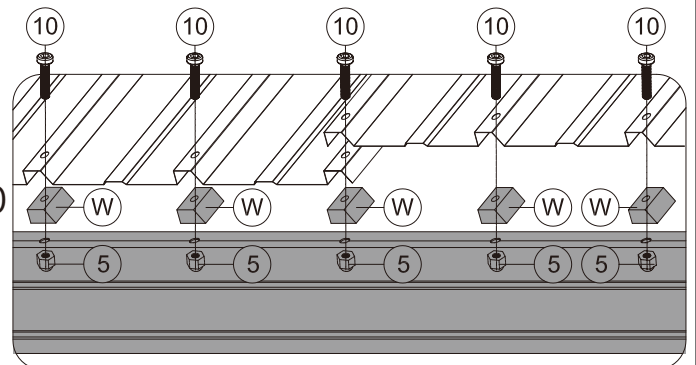

(4) Repeat the above procedures to assemble roof panel #P7 and the opposite side.

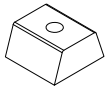

W 24x

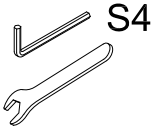

1 1x



M6

5 20x



M6x25

9 4x



M6x28

10 12x

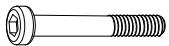

M6x50

12 8x

ATTENTION: The bigger roof panel need to cover the smaller one.

(1) Insert Part #P5 and #P6 into the frame.

(2) Place 5 Part #W between roof panels and solidifying bars. Then secure with 4 Bolt #12, 1 Bolt #9 and 4 Nuts #5.

Solidifying Bar

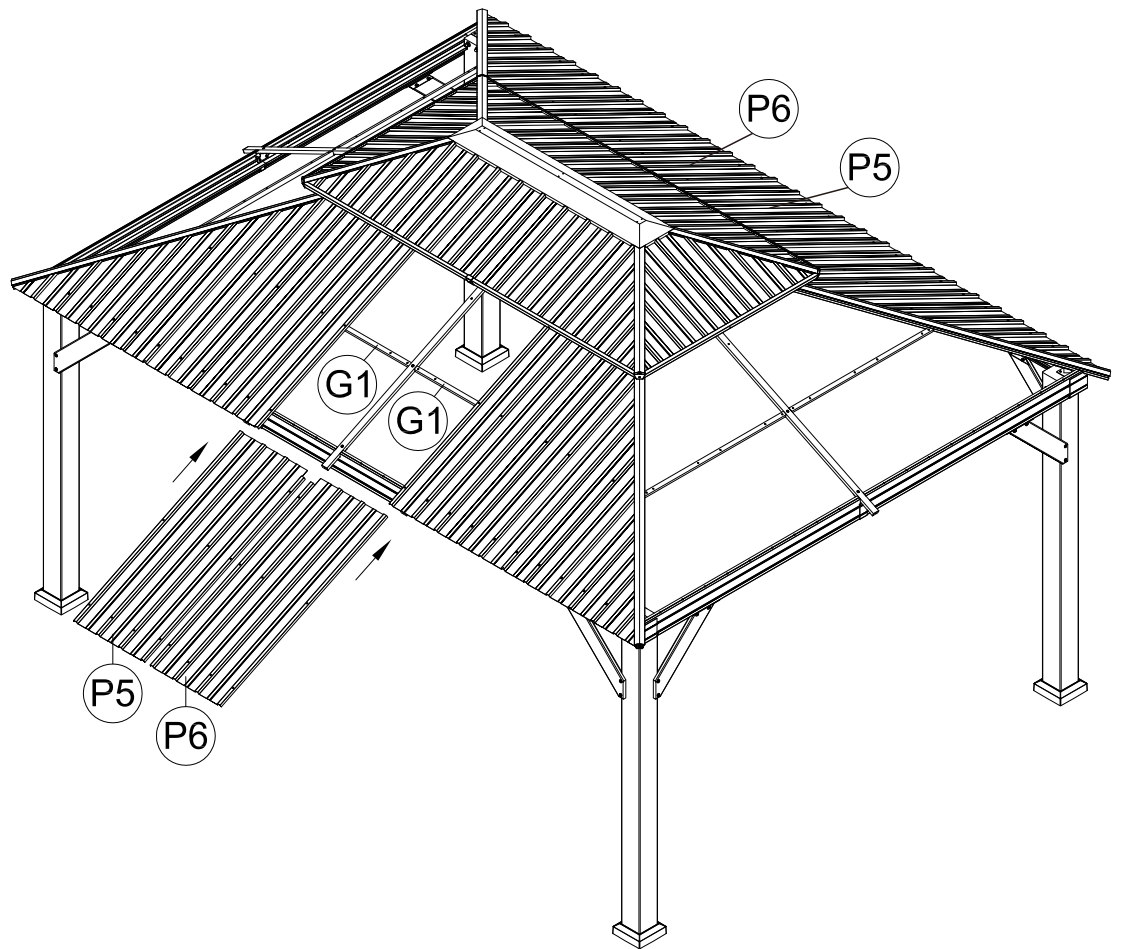
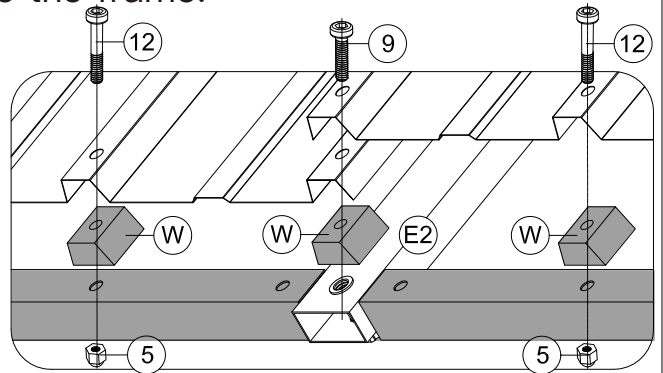

(3) Place 7 Part #W between roof panels and beams. Then secure with 4 Bolts #12, 1 Bolt #9 and 6 Nuts #5.

Beam

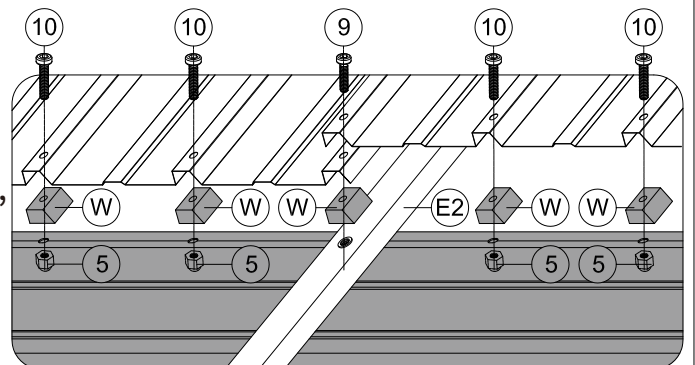

(4) Repeat the above procedures to assemble the opposite side.

ATTENTION: The bigger roof panel need to cover the smaller one.

(1) Insert Part #M1, Part #M2 into the frame.

(2) Place 3 Part #W between roof panels and beams. Then secure with 3 Bolts #10 and 3 Nuts #5.

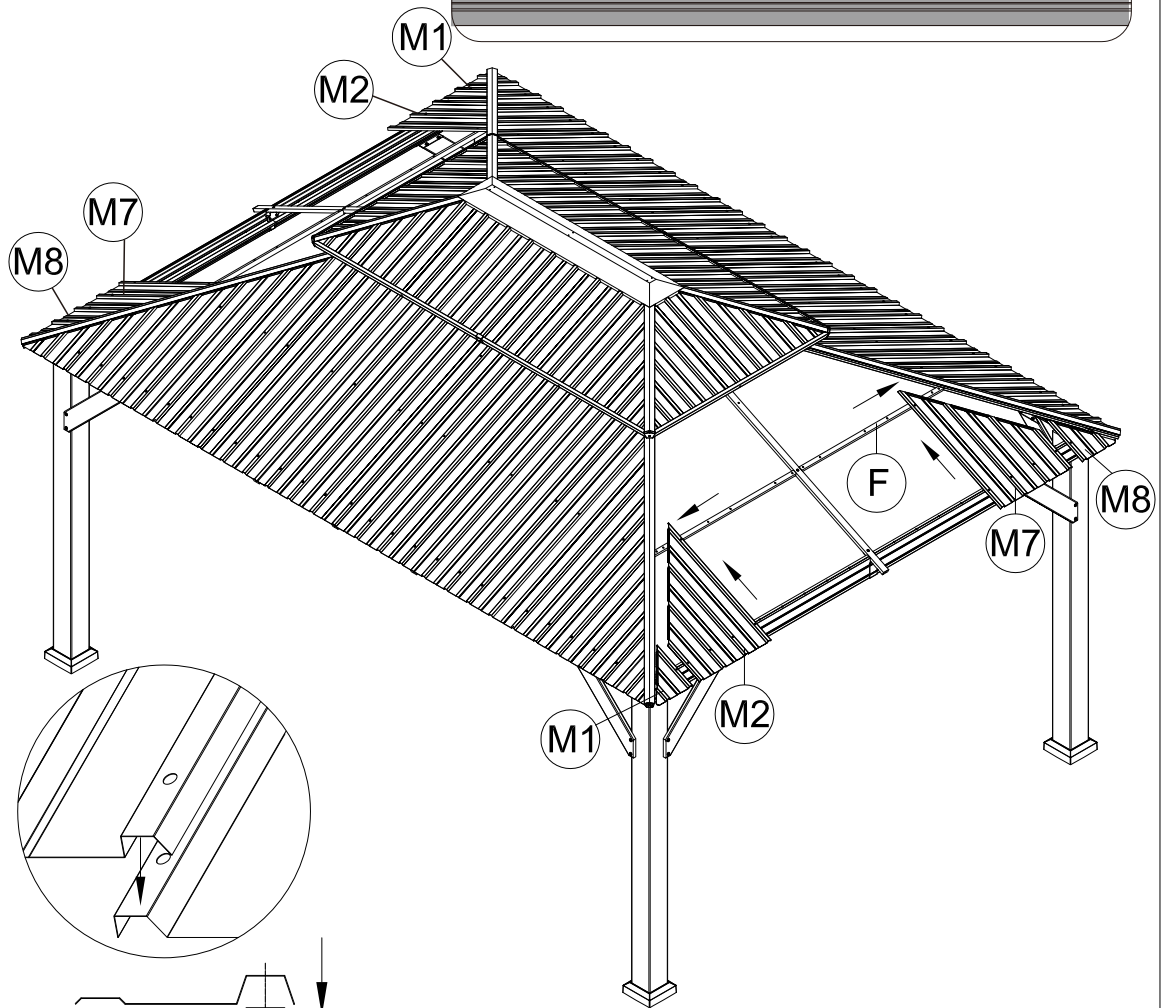
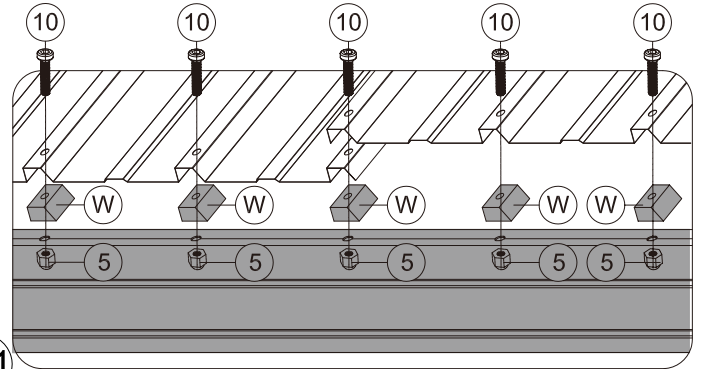
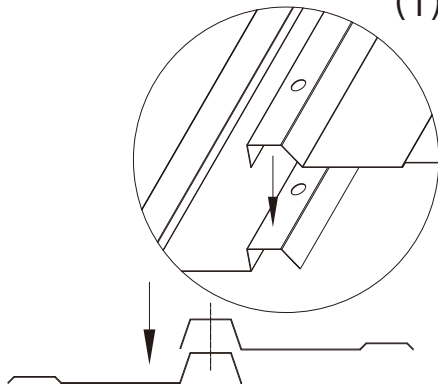

(3) Insert Part #M8, Part #M7 into the frame.

(4) Place 3 Part #W between roof panels and beams. Then secure with 3 Bolts #10 and 3 Nuts #5.

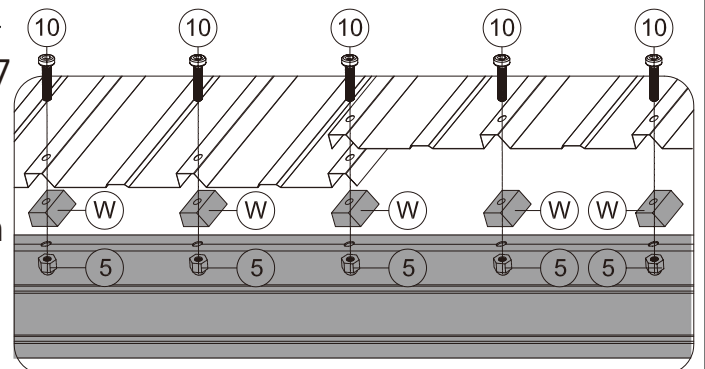

(5) Repeat the above procedures to assemble the opposite side.

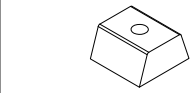

(W) 12x

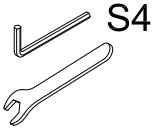

(1) 1x



M6

(5) 12x

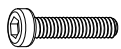

M6x28

(10) 12x

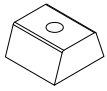

(W) 20x

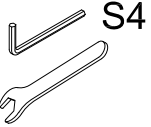

(1) 1x



M6

(5) 20x



M6x28

(10) 12x

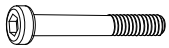

M6x50

(12) 8x

ATTENTION: The bigger roof panel need to cover the smaller one.

(1) Insert Part #M3 into the frame.

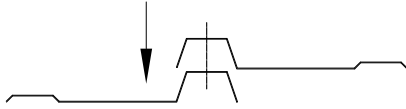

Solidifying Bar

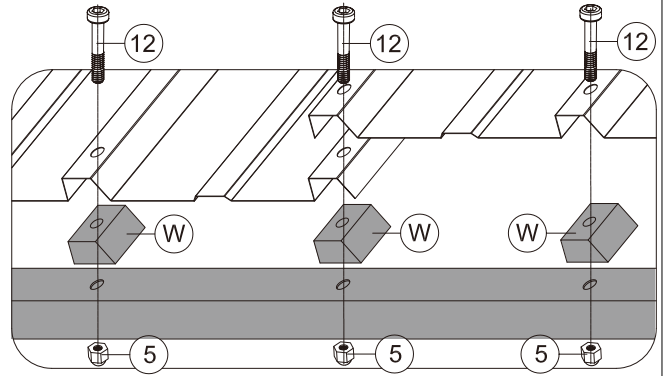

(2) Place 2 Part #W between roof panels #M3 and solidifying bars. Then secure with 2 Bolt #12 and 2 Nuts #5.

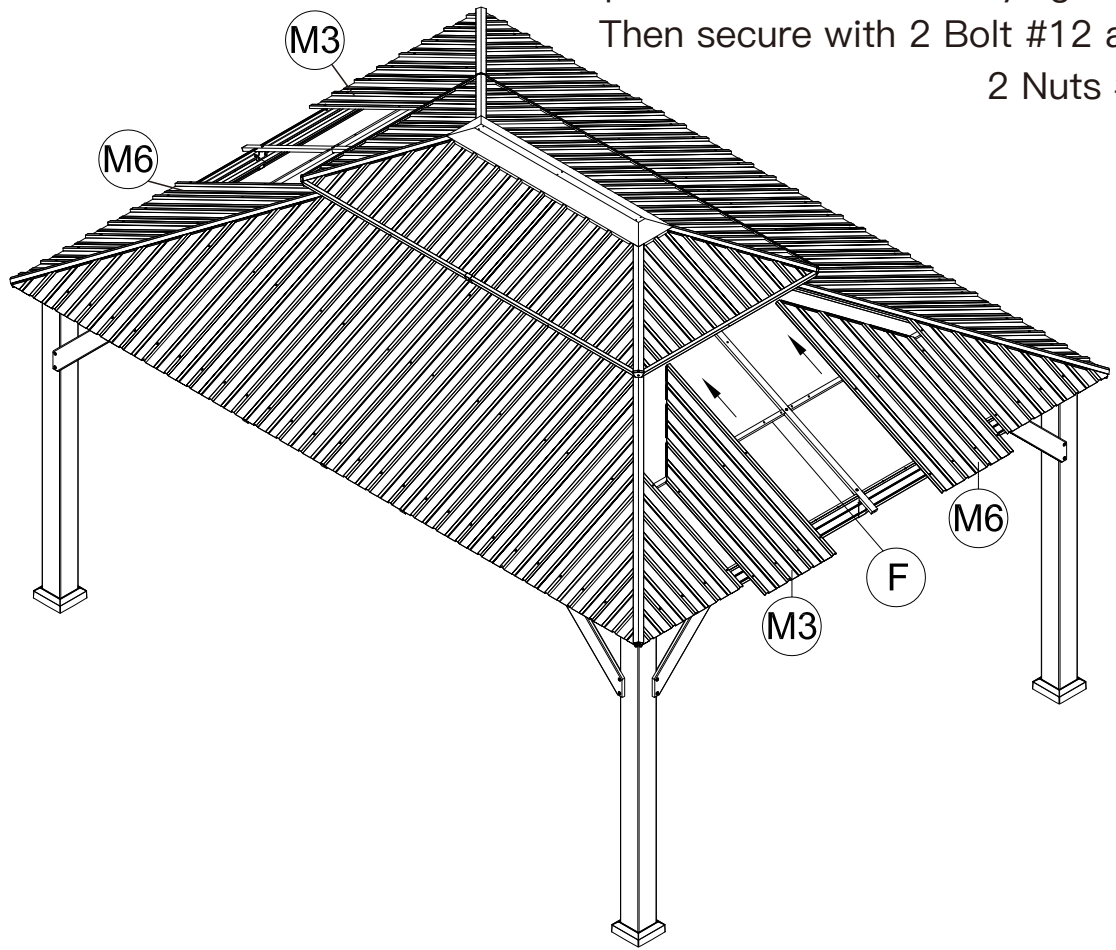

(3) Place 3 Part #W between roof panels #M3 and beams. Then secure with 3 Bolts #10 and 3 Nuts #5.

Beam

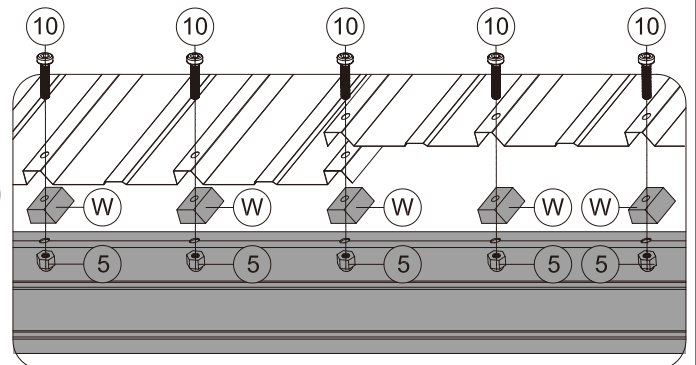

(4) Repeat the above procedures to assemble roof panel #M6 and the opposite side.

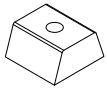

W 24x

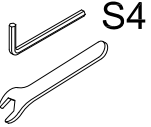

1 1x



M6

5 20x



M6x25

9 4x



M6x28

10 12x

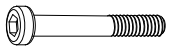

M6x50

12 8x

ATTENTION: The bigger roof panel need to cover the smaller one.

(1) Insert Part #M4 and #M5 into the frame.

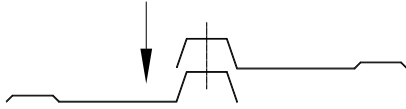

Solidifying Bar

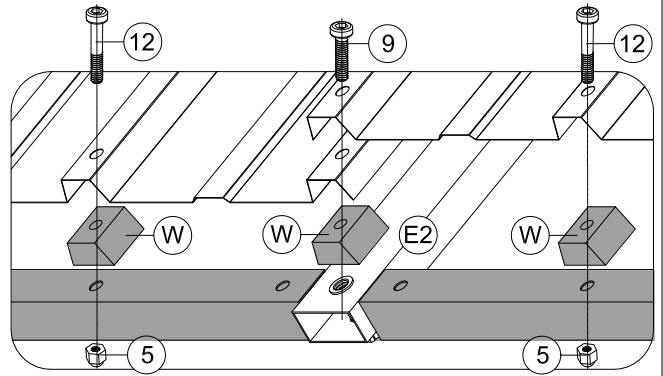

(2) Place 5 Part #W between roof panels and solidifying bars. Then secure with 4 Bolt #12, 1 Bolt #9 and 4 Nuts #5.

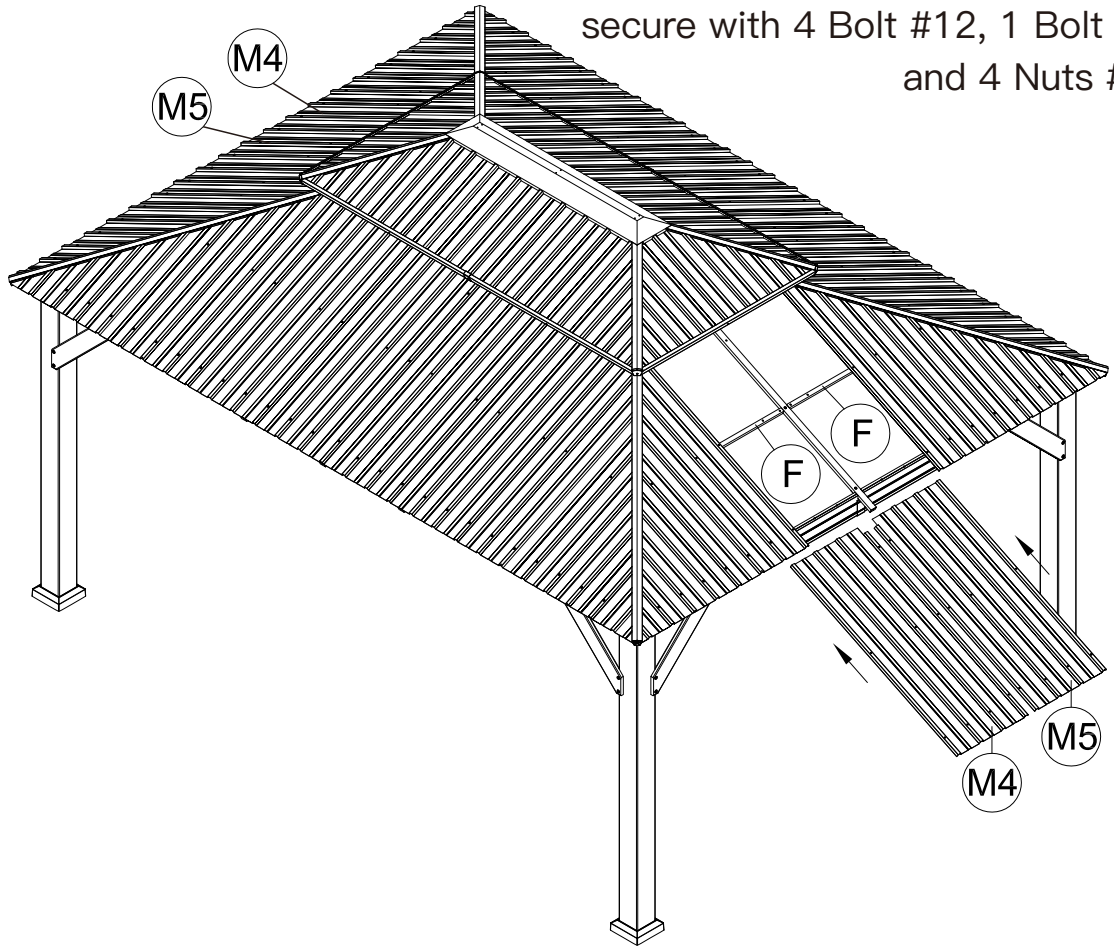

(3) Place 7 Part #W between roof panels and beams. Then secure with 6 Bolts #10, 1 Bolt #9 and 6 Nuts #5.

Beam

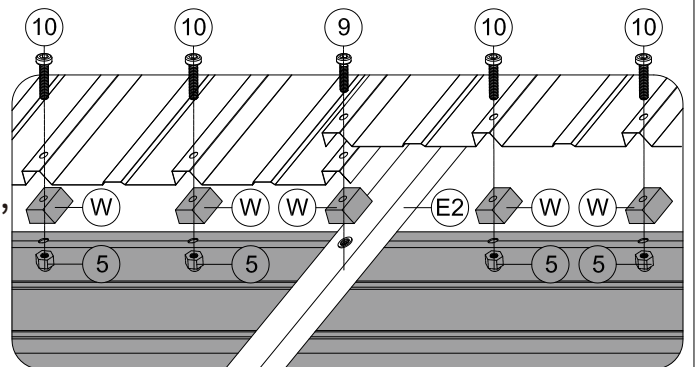

(4) Repeat the above procedures to assemble the opposite side.

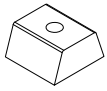

W 4x



1 1x



M6

5 4x

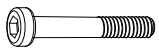

M6x45

11 4x

(1) Place Part #W between roof panels and Part #E2. Then secure with Bolt #11 and Nut #5.

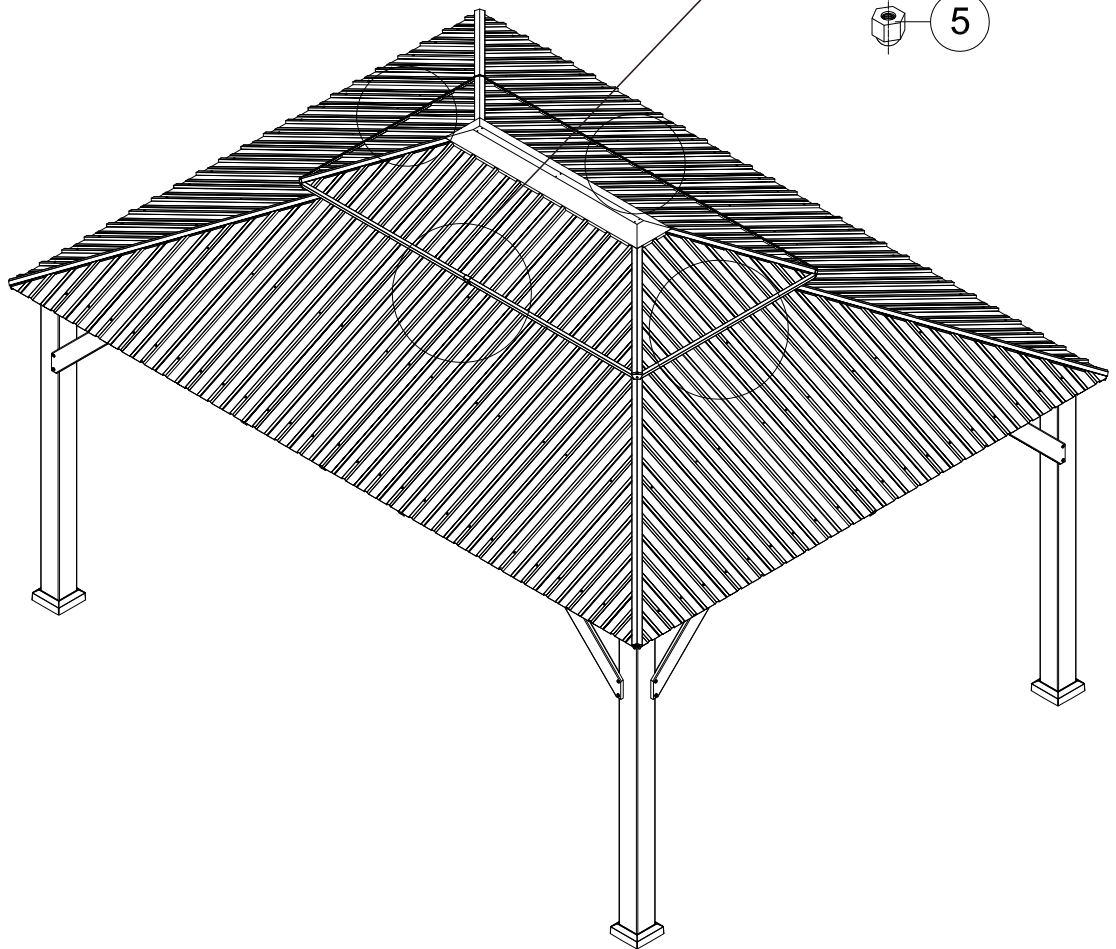
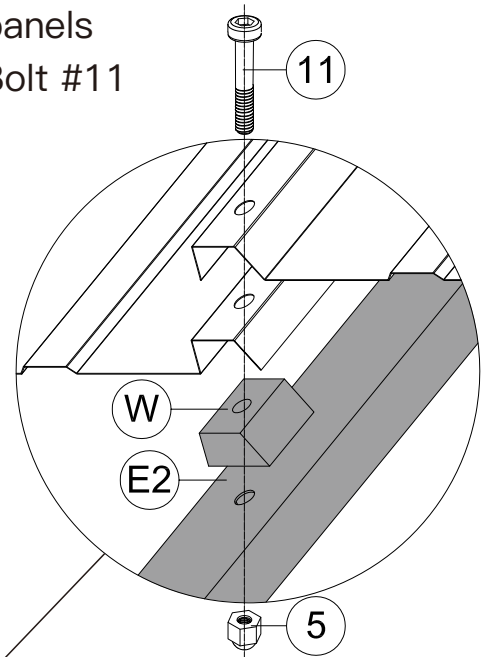

(2) Repeat the above procedures to assemble the other 3 sides.

(1) Place Part #K2 or #K4 and Part #K3 or #K4 on Part #E2;
Put on Part #X2 and secure with Bolt #8.

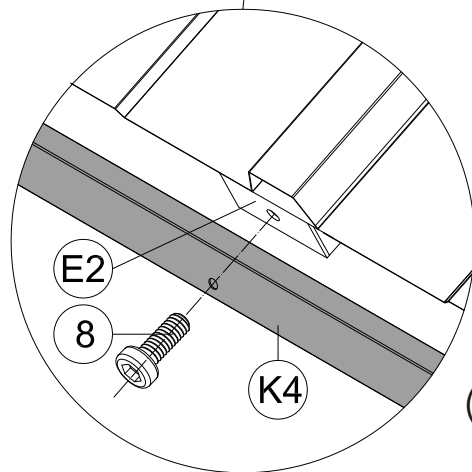
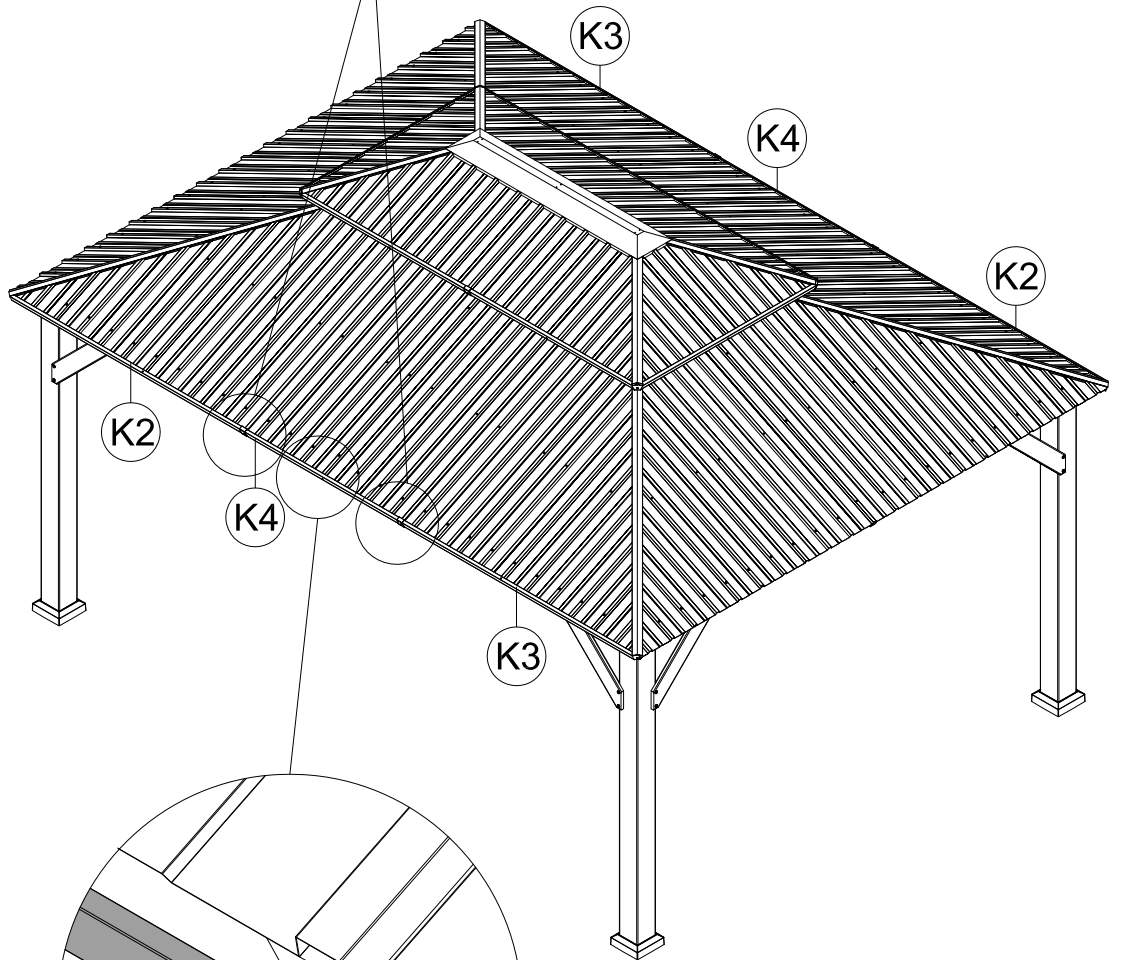
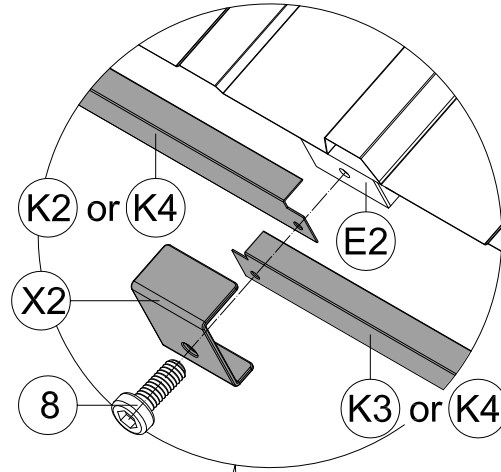

(2) Secure K4 on E2 with Bolt #8.

(3) Repeat the above procedures to assemble the opposite side.

K2 2x

K3 2x

K4 2x

X2 4x

1 1x

8 6x

M6x16

S4

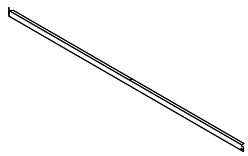

(K) 2x

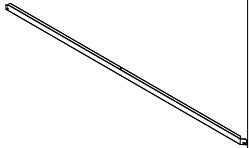

(K1) 2x



(X2) 2x

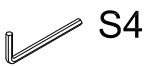

(1) 1x



M6x16

(8) 2x

(1) Place Part #K and Part #K1 on Part #E2;
Put on Part #X2 and secure with Bolt #8.

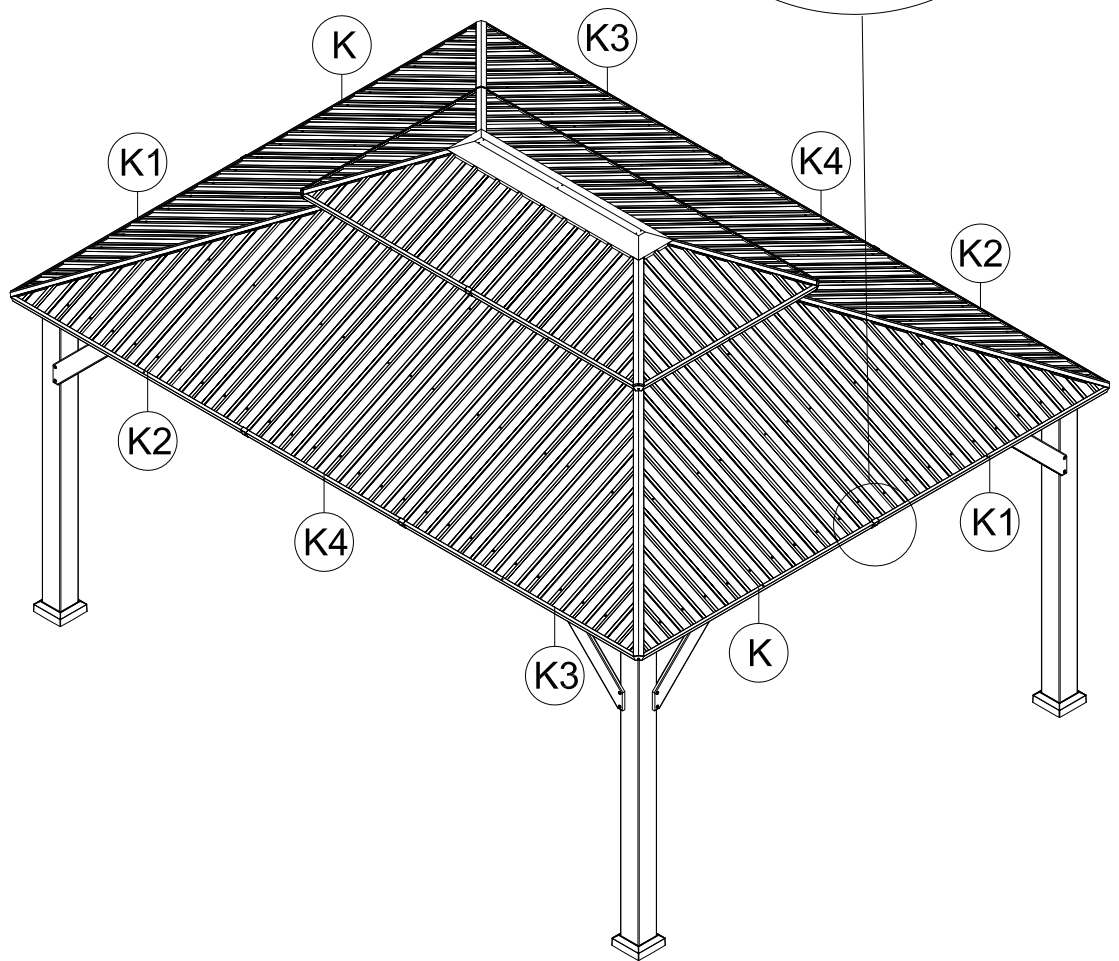
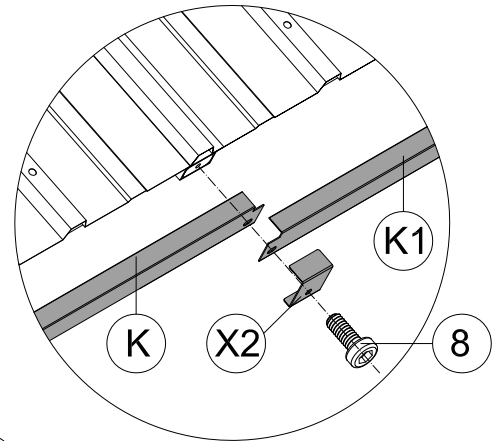

(2) Repeat the above procedures to assemble the opposite side.



X3 4x



ST6.3x15

2 4x

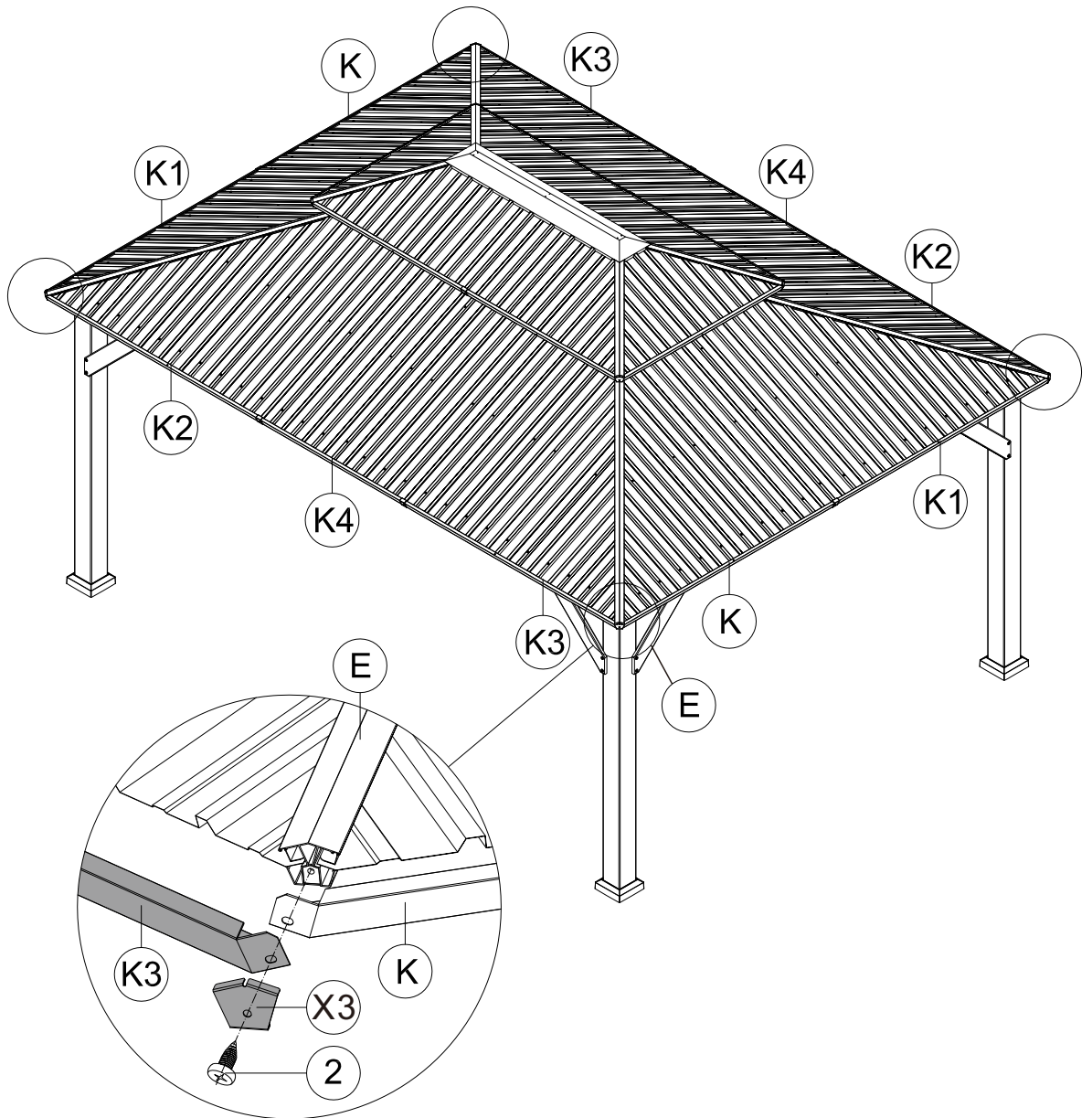

(1) Place Part #K3 and Part #K on Part #E;
Put on Part #X3 and secure with Self-tapping Screw #2.

(2) Repeat the above procedures to assemble the other 3 corners.



ST5x16

3 8x

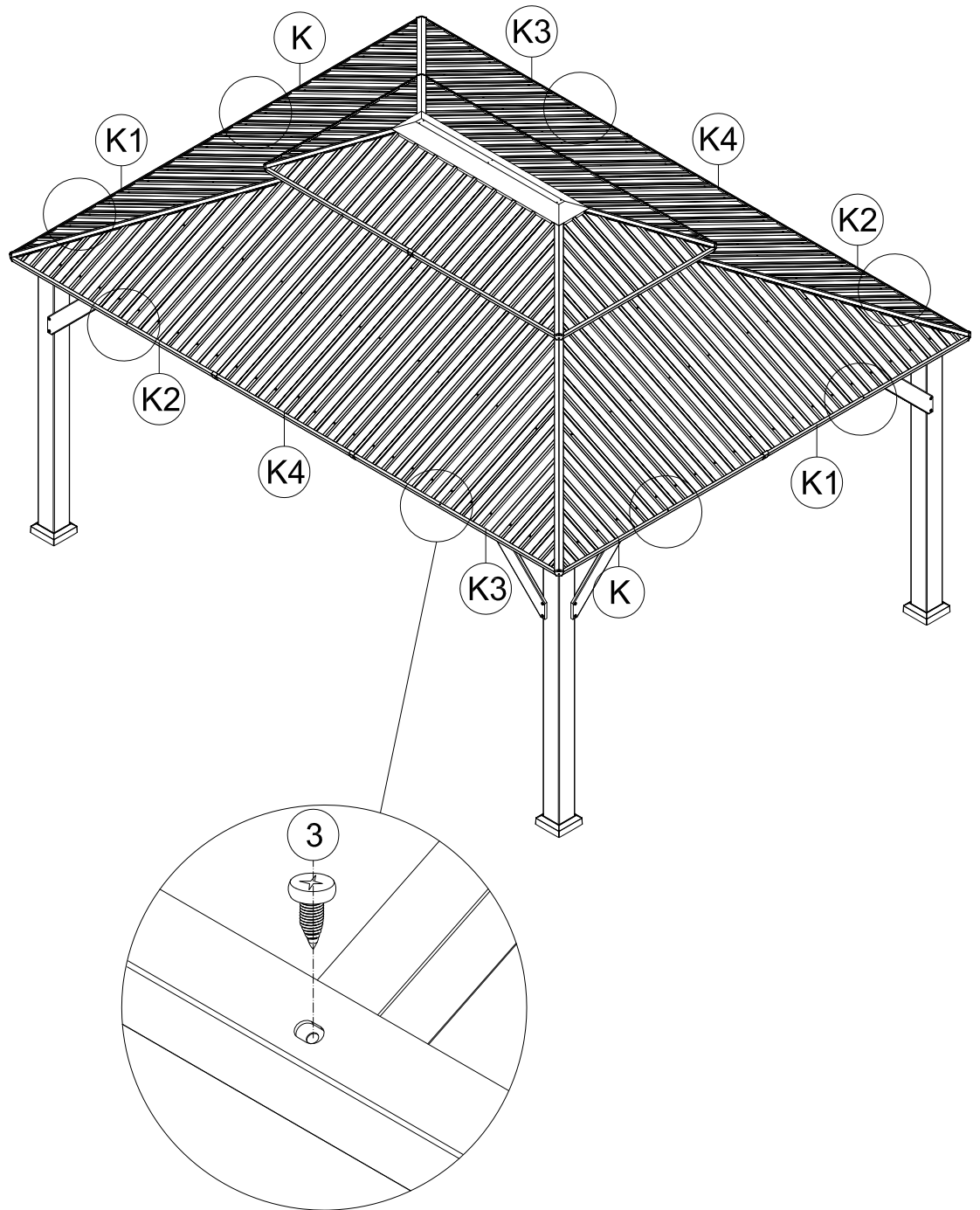

(1) Attach roof panels to finishing bars with 2 Self-tapping Screws #3.

(2) Repeat the above procedures to assemble the other 3 sides.

How to the 128 Hooks into the **Double-track**

Double-track

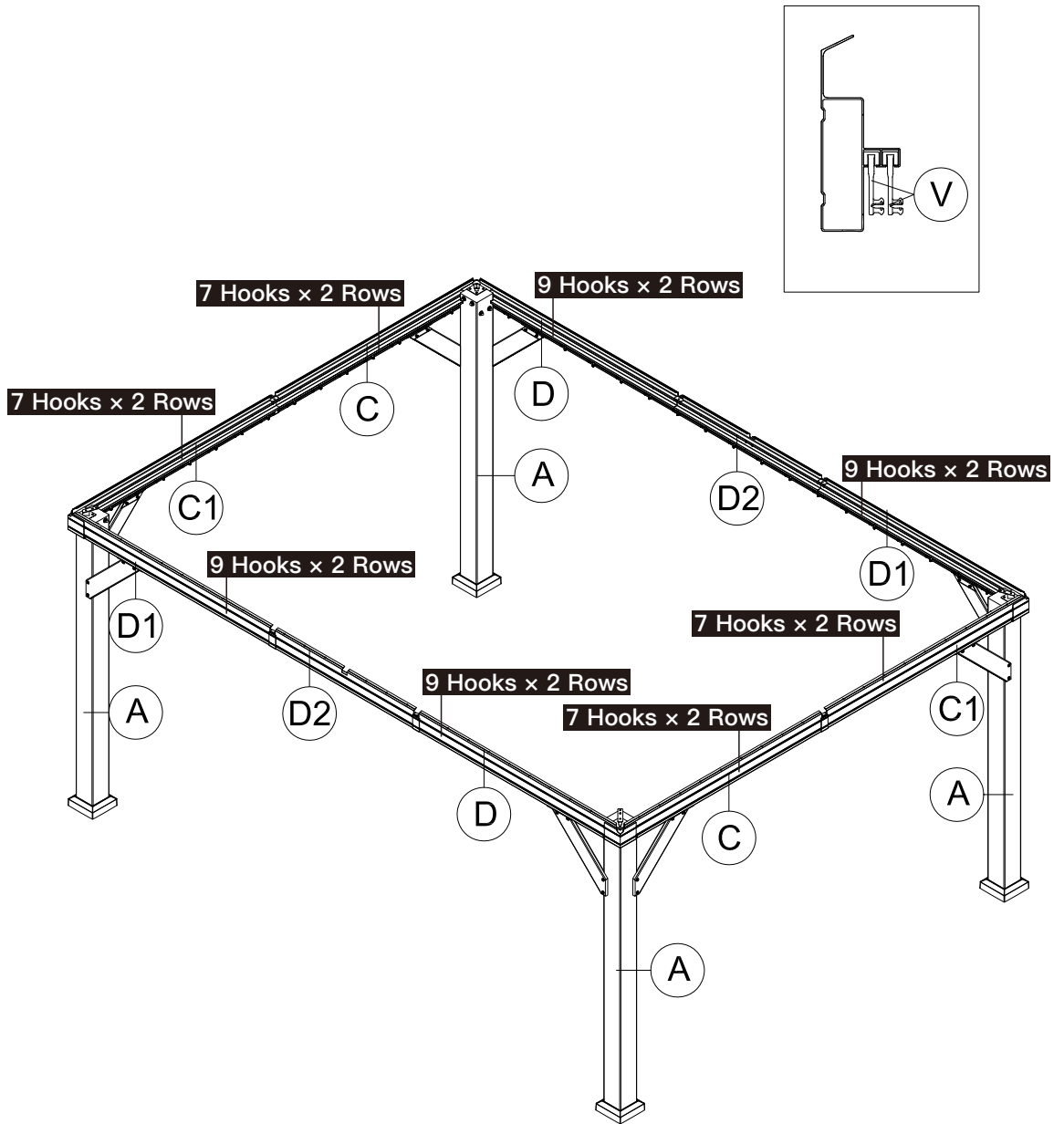

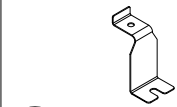

T1 2x



V 56x



1 1x



M6x16

8 2x

(1) Place 7 hooks on each slot of the Sidewall Track(C1&C).

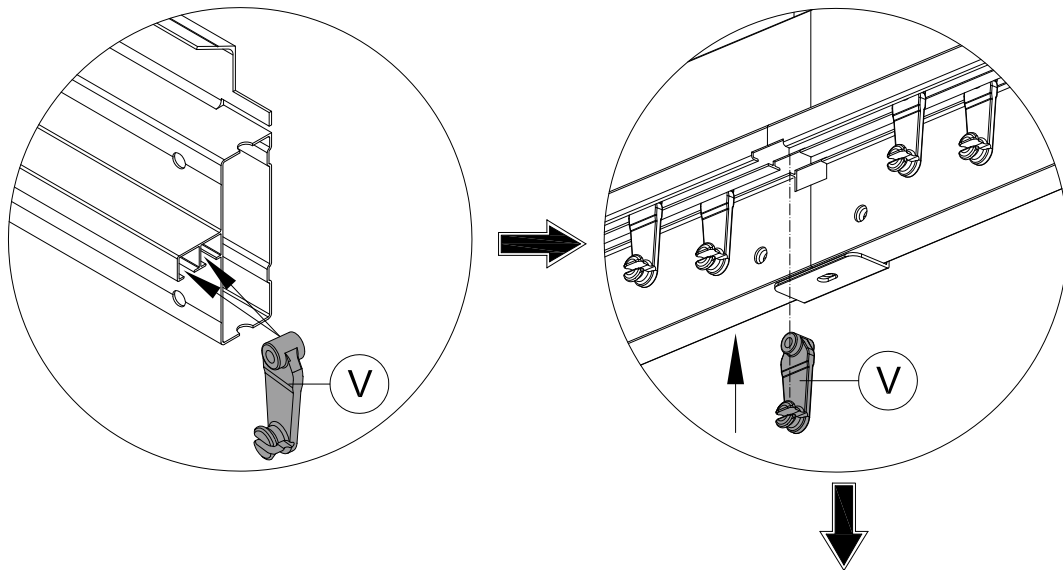

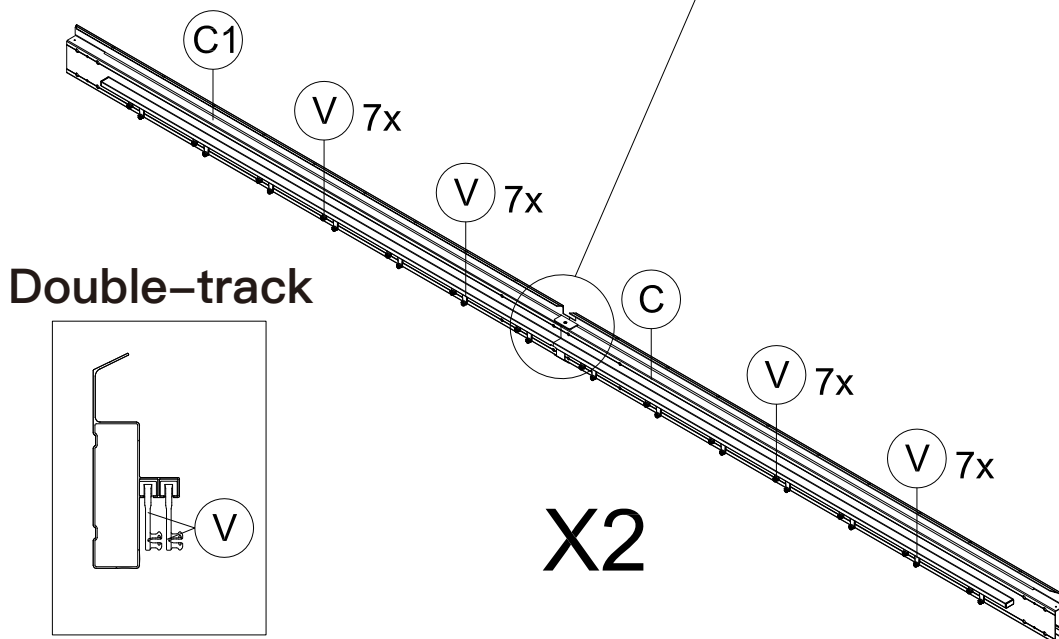
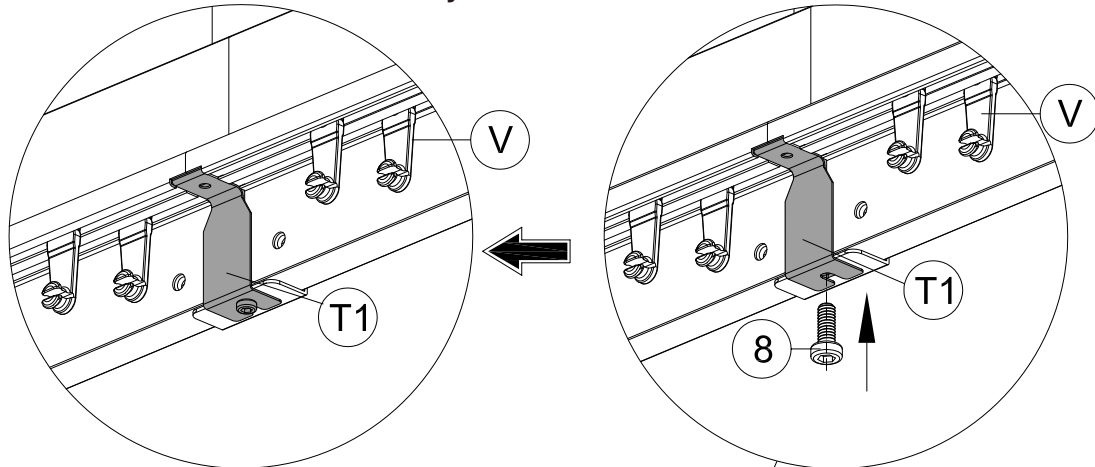

(2) Install Part #T1 at the joint of Part C&C1 with Bolt #8.

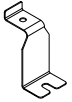

(3) Repeat the above procedures to assemble the opposite side.



T1 2x

V 72x

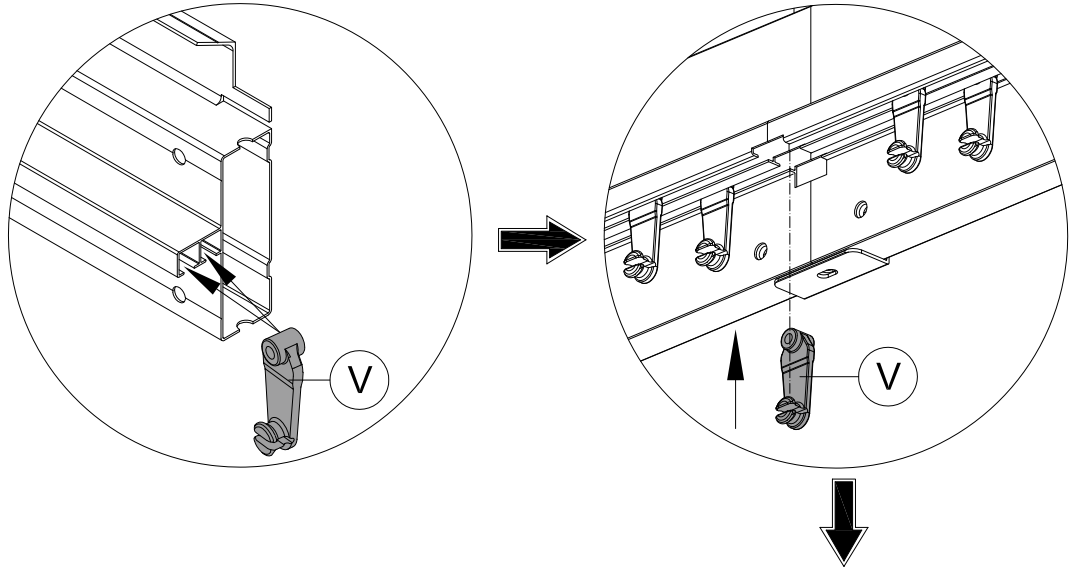

S4
1 1x

M6x16
8 2x

(1) Place 9 hooks on each slot of the Sidewall Track(D&D1).

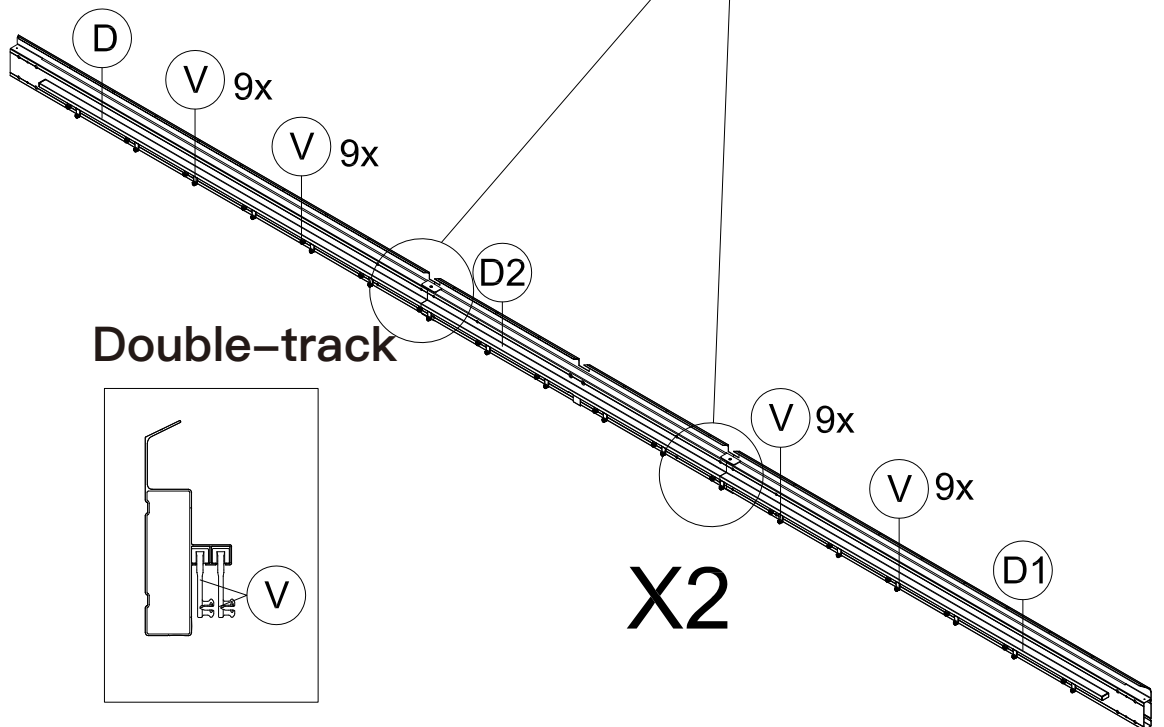
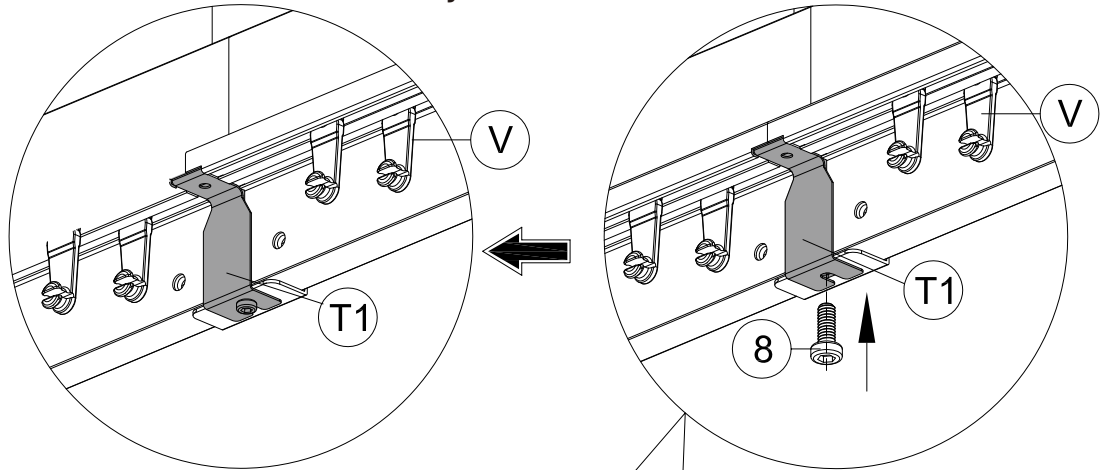

(2) Install Part #T1 at the joint of Part D&D1 with Bolt #8.



(3) Repeat the above procedures to assemble the opposite side.

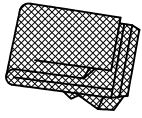

Y1 4x

Hang up Mosquito Sidewalls to **Inside Track**

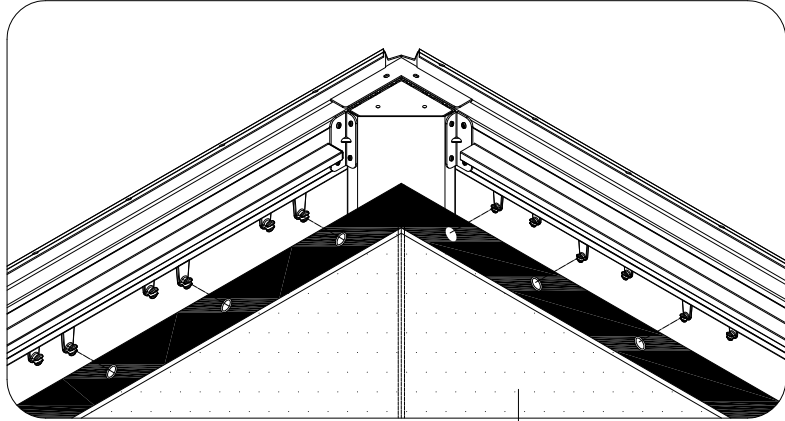

Y1

Y1

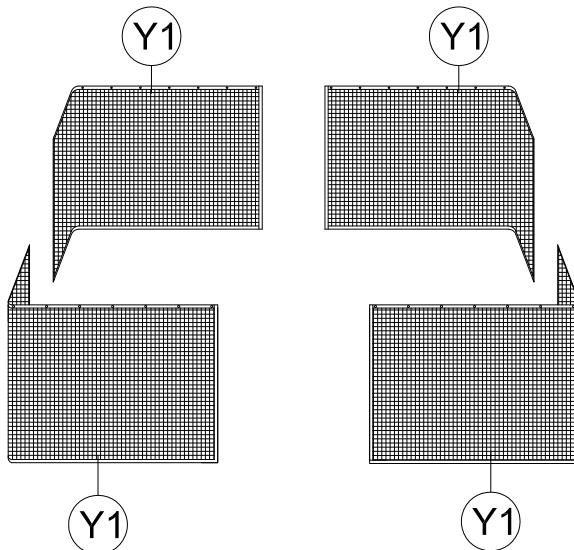
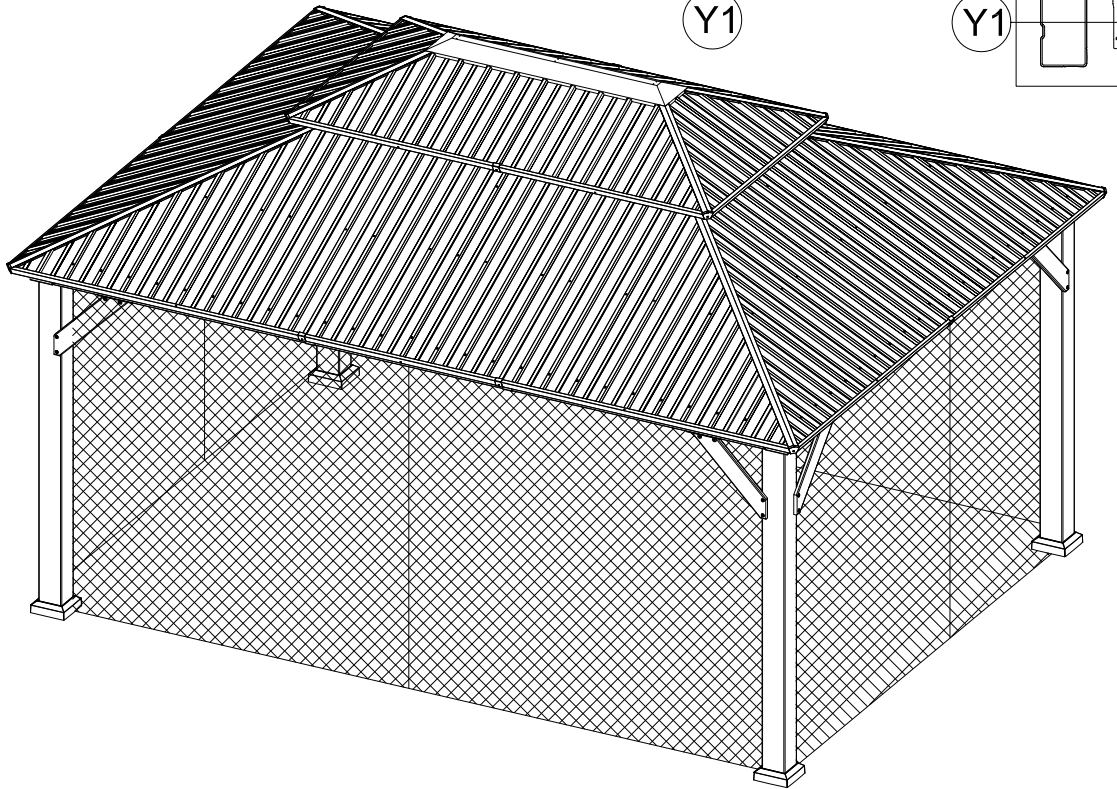
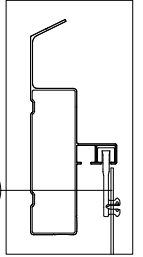

Y1

Y1

Y1

Y1

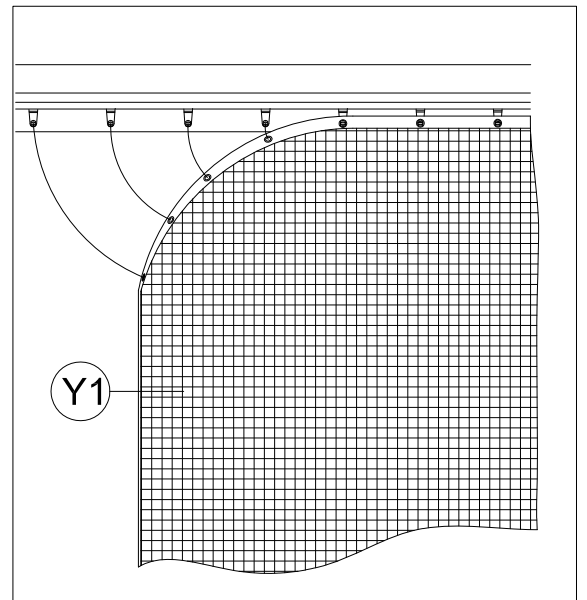

Y1

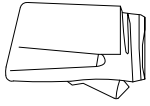

Y 4x

Hang up Solid Sidewalls to **Outside Track**

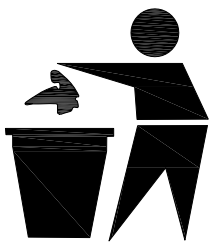
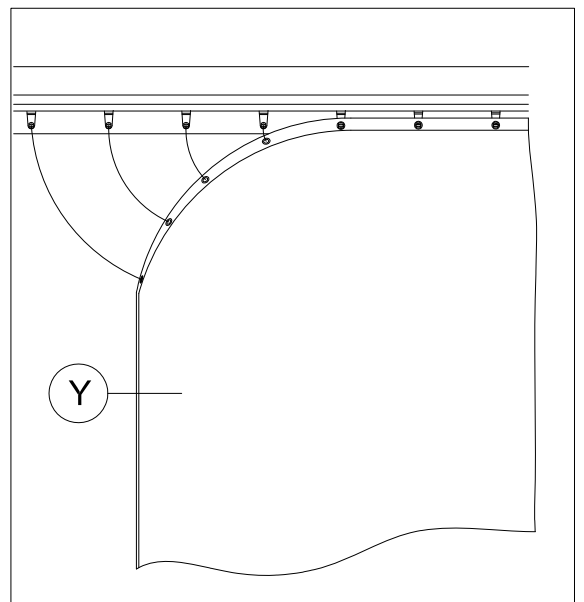
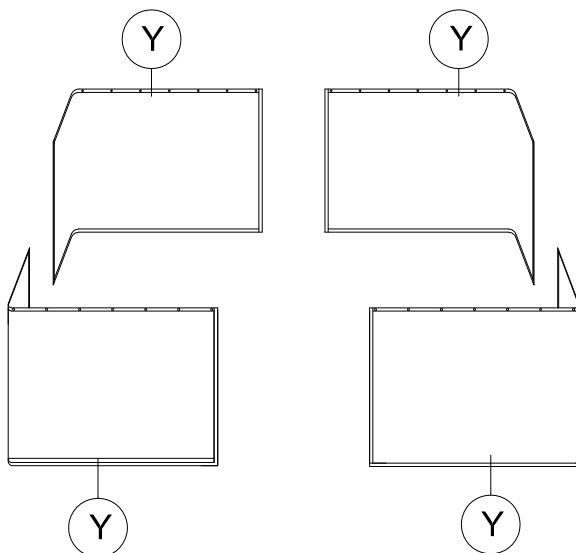
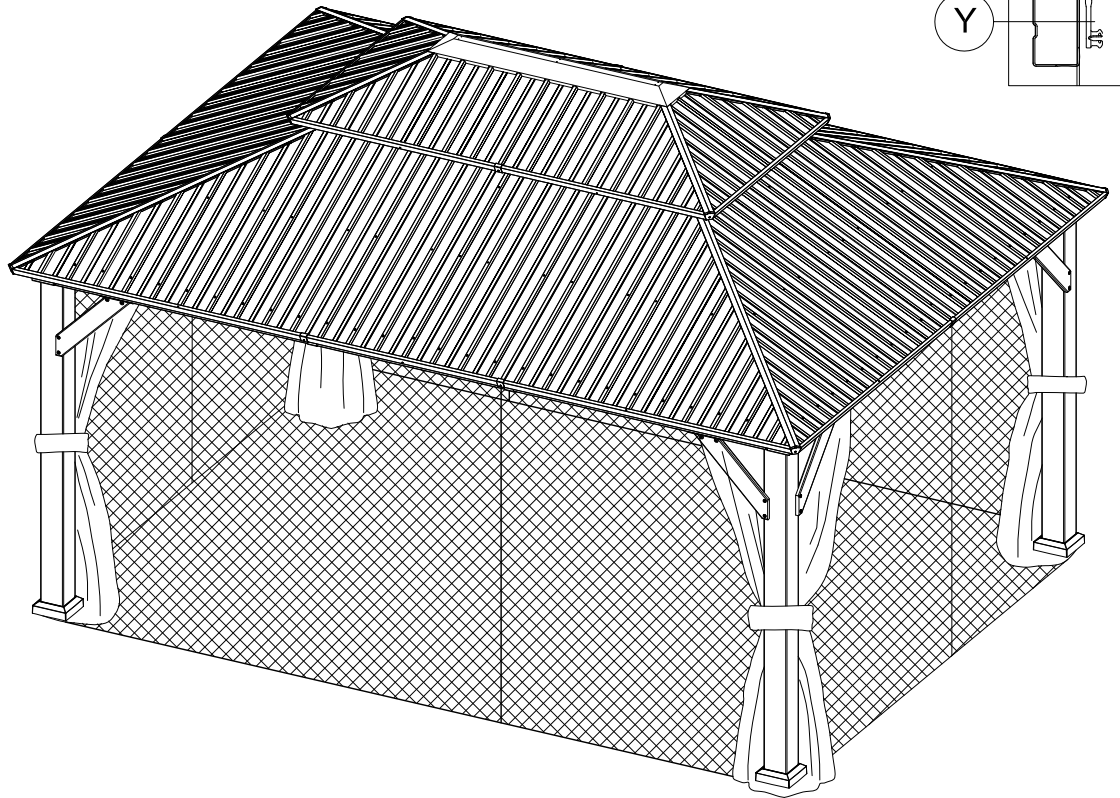
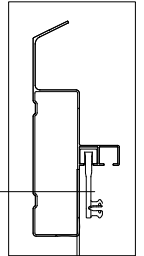
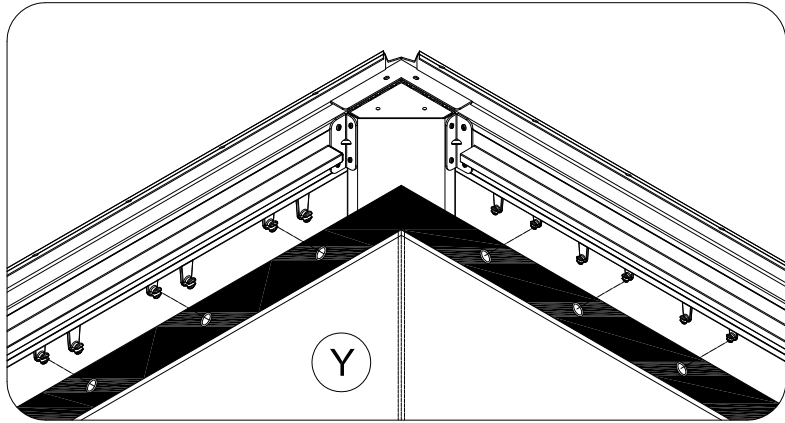

Thanks for your purchase.

At domi outdoor living, we believe in our products.

That's why we provide a 12-month warranty and

friendly, easy-to-reach after-sales service. So if you

have any questions about our product and assembly-

,please feel free to contact us. We will be here for you.

Support:  

After-sales contact email:

service@domioutdoorliving.com

Please tell us your order ID when contact.

Attach photos of damaged part for instant reply.