



ACF - Heating & Cooling buffer store for heat pumps

Carbon steel hot water buffer vessel for the storage of heating and cooling water equipped with high size ports to allow large flow rates. The wide range of capacities (from 12 to 5000 litres) allows their installation in every system, from domestic use to commercial applications. Besides its main function of buffer store, this equipment works also as low loss header thus making the heat source

flow independent to the flow of the system where it is connected. Specially studied to be used in systems with heat pumps, it's coated with a vapour seal insulation with low thermal dispersion. The thermal fluid contained in the cylinder must operate in closed circuit (without oxygen), in order to avoid corrosion phenomena.

HEAT SOURCE



APPLICATION



TECHNICAL FEATURES

Buffer

General features

Material	S 235 Jr Carbon steel
Internal protective treatment	None
External protective treatment	Anti rust protection + epoxy painting
Rating (P max. / T max.)	6 bar / -10 ÷ + 95 °C
Capacity	12 - 5000 L
Warranty	5 years
Insulation	From 12 to 50 L: 20 mm thick polyurethane foam + PVC: Fire retardant class B3 (DIN 4102) - From 100 to 1000 L: 50 mm thick polyurethane foam + PVC: Fire retardant class B3 (DIN 4102) - From 1500 to 2000 L: PEXL + soft polyester + PVC: Fire retardant class B2 (DIN 4102)
In compliance with	- Pressure Equipment Directive (PED) 2014/68/UE Art. 4 Para 3 - Energy related Products (Erp) Directive 2009/125/CE

ACCESSORIES (page 218)



Thermostat



Thermometer



1 1/2 electric immersion heater

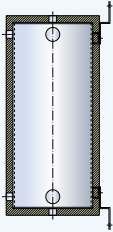

Hard insulation with rigid polyurethane foam and PVC jacket

CODE	INSULATION THICK. (mm)	ErP CLASS	HEAT LOSS S (W)	REAL CAPACITY (L)
ACF 00012 R	25	C	39,1	12,2
ACF 00025 R	25	C	46,0	25,2
ACF 00050 R	25	C	55,8	49,5

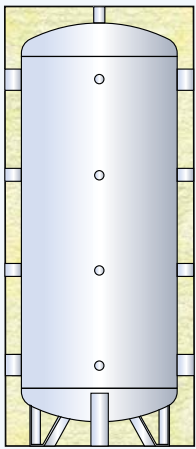

Hard insulation with rigid polyurethane foam and PVC jacket

CODE	INSULATION THICK. (mm)	ErP CLASS	HEAT LOSS S (W)	REAL CAPACITY (L)
ACF 00100 R	50	B	46,0	97,0
ACF 00200 R	50	B	58,9	189,3
ACF 00300 R	50	B	68,1	289,8
ACF 00500 R	50	B	80,5	499,8
ACF 00800 R	50	C	117,5	749,3
ACF 01000 R	50	C	130,4	931,0

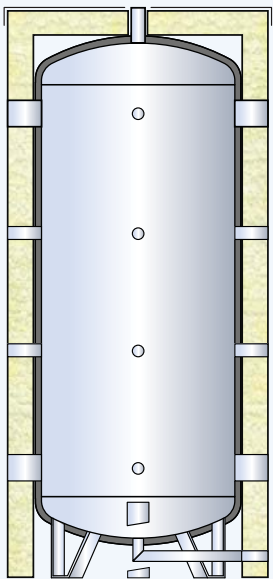

Vapour seal insulation with PEXL + soft thermal insulation with polyester and PVC jacket

CODE	VAPOUR SEAL INSULATION THICK. (mm)	THERMAL INSULATION THICK. (mm)	ErP CLASS	HEAT LOSS S (W)	REAL CAPACITY (L)
ACF 01500 PF	10	130	C	163,8	1472,4
ACF 02000 PF	10	130	C	181,2	1950,0
ACF 02500 PF	10	100	-	-	2493,5
ACF 03000 PF	10	100	-	-	2957,5
ACF 04000 PF	10	100	-	-	3894,4
ACF 05000 PF	10	100	-	-	5005,2

12 - 50 L

100 - 1000 L

1500 - 5000 L

LEGEND

- a . System Inlet/Outlet
- b . Control instruments
- g . Vent / safety valve
- p . Free connection
- s . Drain

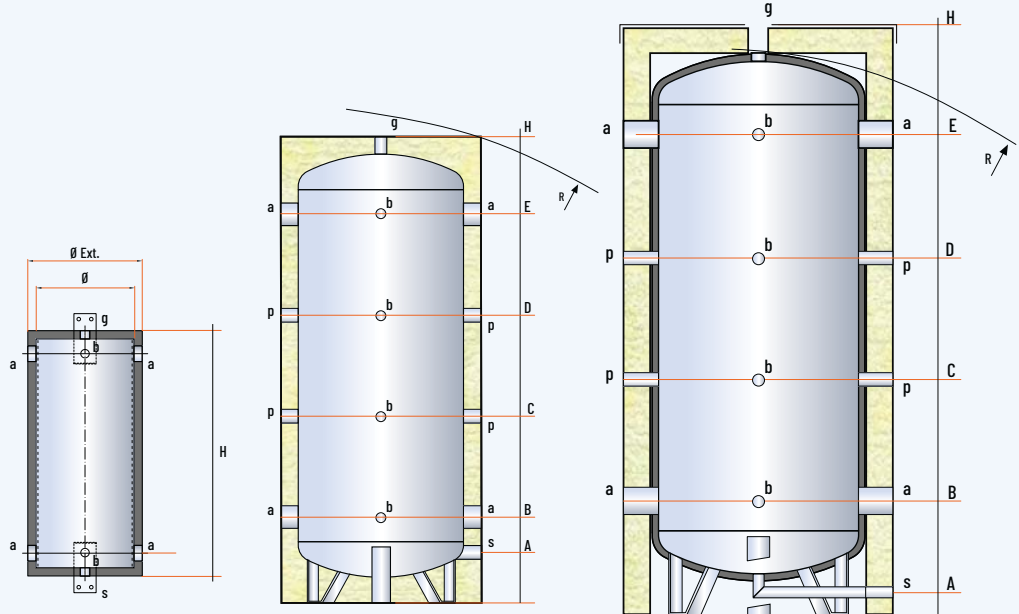

MODEL	DIMENSIONS (mm)		Ø EXT **	R *	WEIGHT (kg)
	Ø	H			
ACF 00012 R	220	380	270	-	9
ACF 00025 R	220	720	270	-	12
ACF 00050 R	300	750	350	-	18
ACF 00100 R	400	915	500	1055	31
ACF 00200 R	450	1330	550	1450	33
ACF 00300 R	500	1610	600	1730	42
ACF 00500 R	650	1665	750	1840	68
ACF 00800 R	790	1700	890	1930	86
ACF 01000 R	790	2060	890	2255	102
ACF 01500 PF	1000	2145	1280	2235	147
ACF 02000 PF	1100	2395	1380	2465	212
ACF 02500 PF	1200	2595	1420	2690	358
ACF 03000 PF	1250	2795	1470	2885	428
ACF 04000 PF	1400	2925	1620	3030	499
ACF 05000 PF	1600	2955	1820	3090	580

* For capacities from 100 to 1000 litres, the tilt height refers to the insulated cylinder

** The insulation is not removable except for models from 1500 to 5000 litres (only the soft polyester insulation is removable)

MODEL	HEIGHTS (mm)					CONNECTIONS (GAS)				
	A	B	C	D	E	a	b	g	p	s
ACF 00012 R	-	-	-	-	-	1" ¼	-	½"	-	½"
ACF 00025 R	-	-	-	-	-	1" ¼	-	½"	-	½"
ACF 00050 R	-	-	-	-	-	1" ¼	½"	½"	-	½"
ACF 00100 R	105	210	380	545	710	1" ½	½"	1" ¼	1" ½	1"
ACF 00200 R	135	220	510	805	1095	1" ½	½"	1" ¼	1" ½	1"
ACF 00300 R	125	275	625	975	1320	2"	½"	1" ¼	1" ½	1"
ACF 00500 R	155	305	655	1005	1350	3"	½"	1" ¼	1" ½	1"
ACF 00800 R	170	320	670	1020	1365	3"	½"	1" ½	1" ½	1"
ACF 01000 R	170	320	785	1250	1710	3"	½"	1" ½	1" ½	1"
ACF 01500 PF	110	485	915	1350	1780	3"	½"	1" ½	1" ½	1"
ACF 02000 PF	100	490	1020	1550	1985	3"	½"	1" ½	1" ½	1"
ACF 02500 PF	100	540	1060	1580	2095	4"	½"	1" ½	1" ½	1"
ACF 03000 PF	90	535	1120	1705	2290	4"	½"	1" ½	1" ½	1"
ACF 04000 PF	120	615	1200	1785	2370	4"	½"	1" ½	1" ½	1"
ACF 05000 PF	100	620	1205	1785	2375	4"	½"	1" ½	1" ½	1"

Disclaimer: this layout is purely indicative. It does not replace consultant's design

LEGEND

- 2 . Drain
- 3 . Safety valve
- 4 . Strainer
- 5 . Pressure reducing valve
- 7 . Summer/winter diverter valve
- 12 . Heating system expansion vessel

SUMMER SETTING

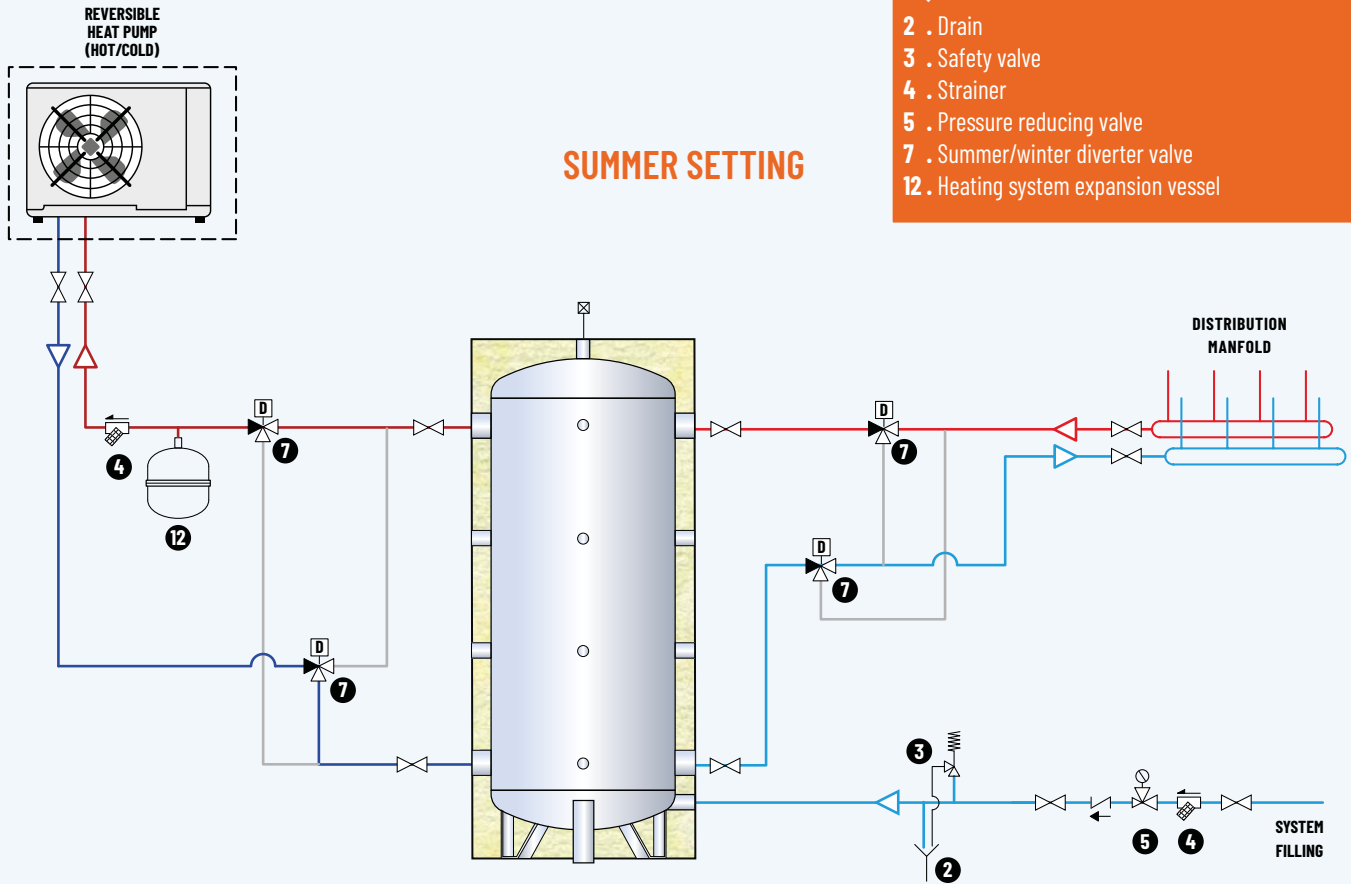

WINTER SETTING

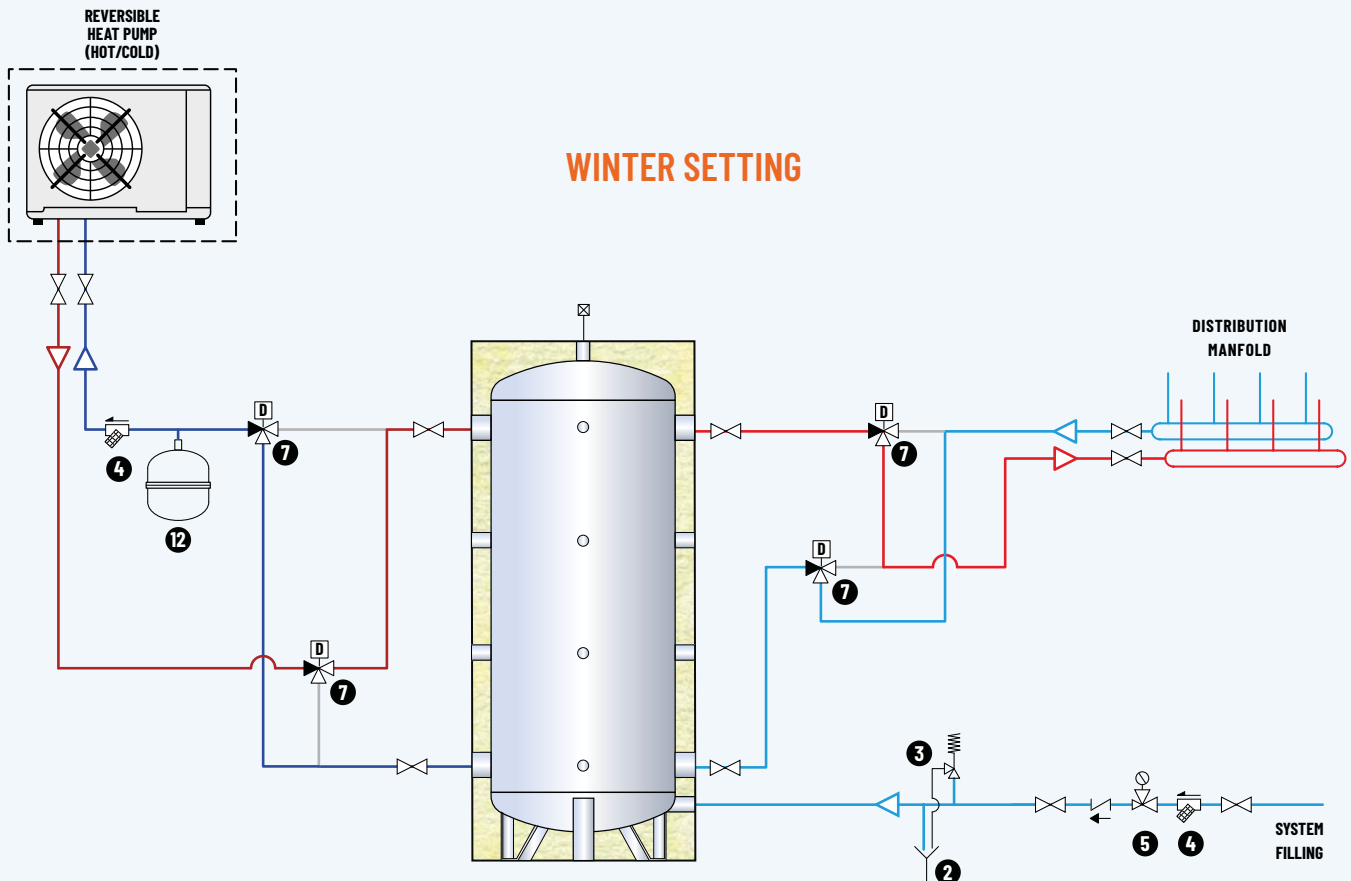

PRIMARY WATER
THERMAL STORES