

# PERGOLUX

Et kvalitetsmerke fra Norge

A Quality Brand from Norway

Eine Qualitätsmarke aus Norwegen

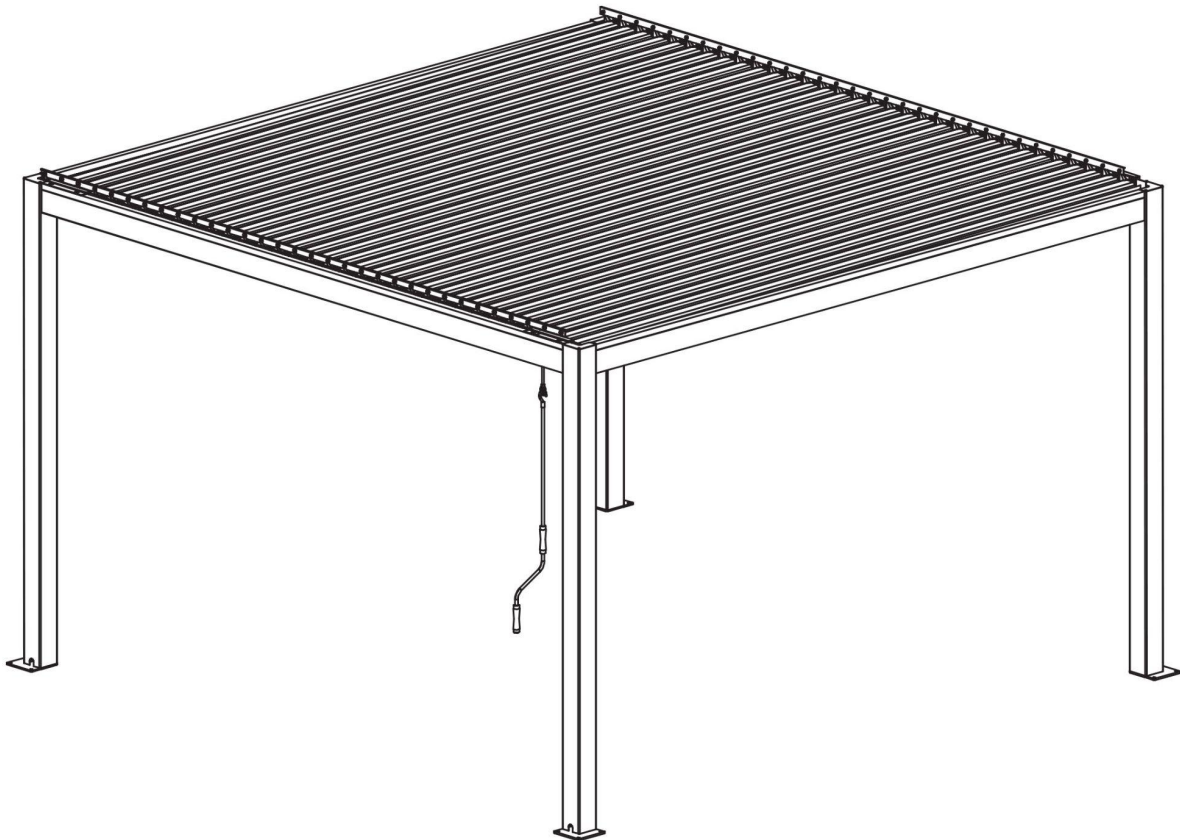

PERGOLUX PERGOLA 3×3/3×4/4×4  
FRITTSTÅENDE / FREESTANDING / FREISTEHEND

# **Innholdsfortegnelse / Table of Content / Inhaltsverzeichnis**

<b>Innholdsliste / List of Items / Artikkelliste .....</b>	<b>3-8</b>
<b>Verktøy / Tools / Werkzeuge .....</b>	<b>9</b>
<b>Montasje / Instalation / Montage .....</b>	<b>10-41</b>
- Norsk .....	10
- English .....	20
- Deutsch .....	28
<b>Sikkerhetsinstruksjoner / Security instructions / Sicherheitshinweise .....</b>	<b>37</b>
<b>Avsluttende ord / Closing remarks / Schulsworte .....</b>	<b>38-39</b>

## Innholdsliste / List of Items / Artikelliste

*Kontroller at du har alle delene før montering. Kontakt oss om noe skulle mangle /  
Please check all parts according to the parts list before assembling the pergola /  
Bitte den Inhalt der Pakete auf Vollständigkeit überprüfen*

### **PERGOLUX PERGOLA 3×3**

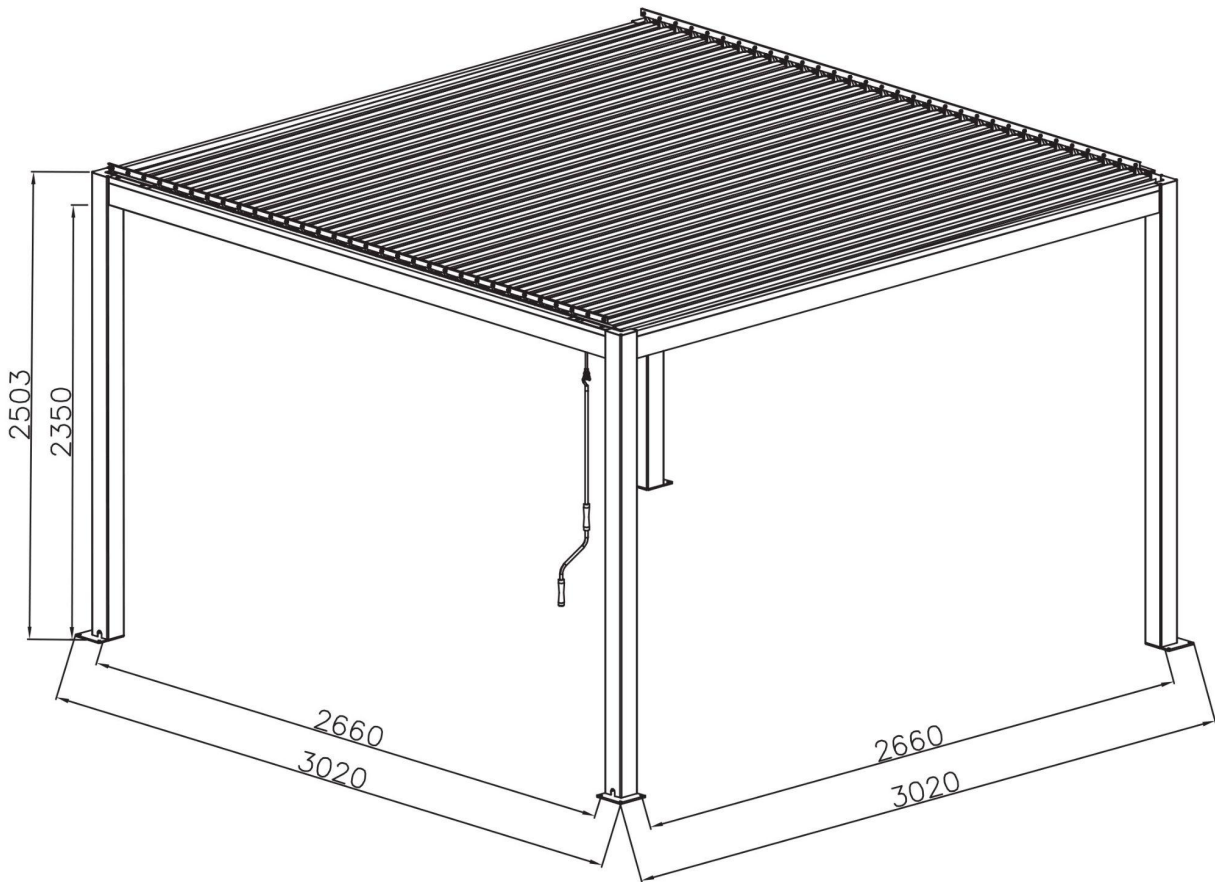









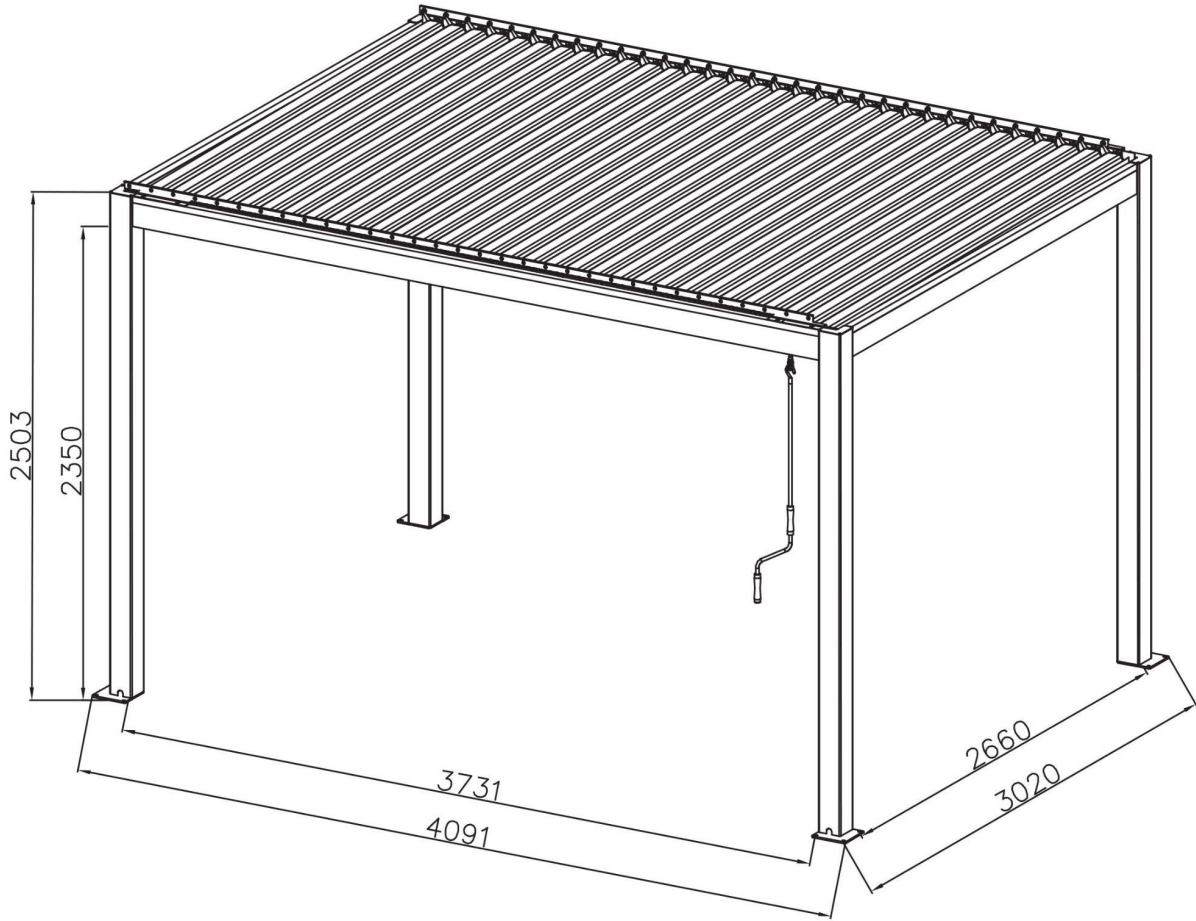





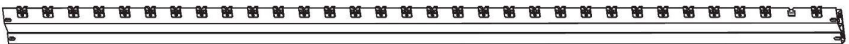





Ⓐ1			x 1
Ⓐ2			x 1
Ⓑ1			x 2
Ⓔ1			x 2
Ⓔ1			x 2
Ⓓ1			x 2
Ⓓ2			x 2
Ⓖ			x 22
Ⓕ			x 1
Ⓙ			x 2 (4)











①		x 28	⑦		x 1
②		x 4	⑧		x 2
③		x 4	⑨		x 2
④		x 46	⑩		x 4
⑤		x 46	⑪		x 8
⑥		x 46	⑫		x 12

! Merk: Noen av delene er allerede forhåndsskrudd  
 ! Note: Some of the parts may already be pre-assembled  
 ! Hinweis: Einige Teile sind bereits vorgeschraubt

# PERGOLUX PERGOLA 3x4











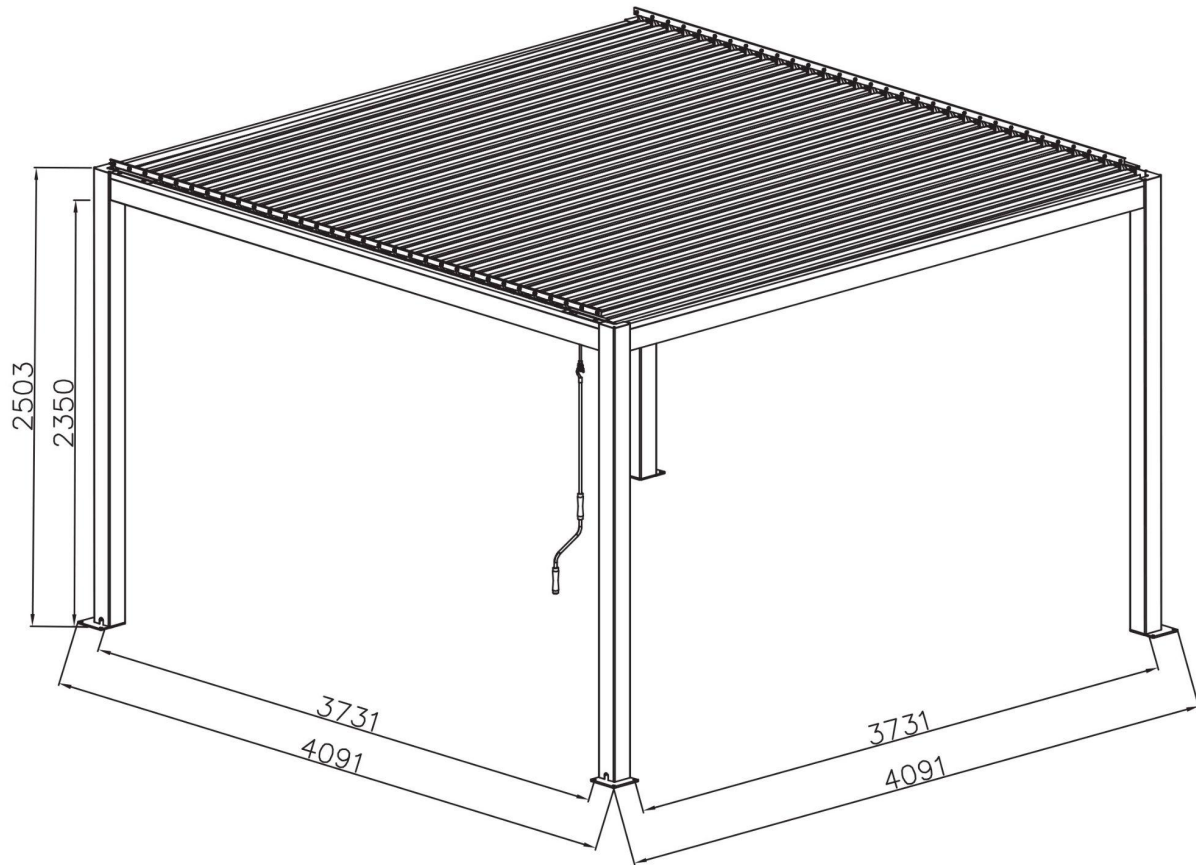





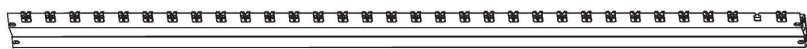





(A1)			x 1
(A2)			x 1
(B1)			x 2
(E1)			x 2
(F1)			x 2
(D1)			x 2
(D2)			x 2
(G)			x 31
(H)			x 1
(J)			x 2







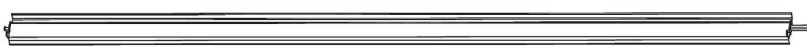



(1)		x 28	(7)		x 1
(2)		x 4	(8)		x 2
(3)		x 4	(9)		x 2
(4)		x 64	(10)		x 4
(5)		x 64	(11)		x 8
(6)		x 64	(12)		x 12

- !** Merk: Noen av delene er allerede forhåndsskrudd
- !** Note: Some of the parts may already be pre-assembled
- !** Hinweis: Einige Teile sind bereits vorgeschraubt

# PERGOLUX PERGOLA 4x4

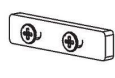

(A1)			x 1
(A2)			x 1
(B1)			x 2
(E1)			x 2
(F1)			x 2
(D1)			x 2
(D2)			x 2
(G)			x 31
(H)			x 1
(J)			x 2

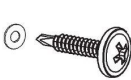
(1)		x 28	(7)		x 1
(2)		x 4	(8)		x 2
(3)		x 4	(9)		x 2
(4)		x 64	(10)		x 4
(5)		x 64	(11)		x 8
(6)		x 64	(12)		x 12

- ! Merk: Noen av delene er allerede forhåndsskrudd
- ! Note: Some of the parts may already be pre-assembled
- ! Hinweis: Einige Teile sind bereits vorgeschraubt



## Verktøy / Tools / Werkzeuge

*Det anbefales å være minst 2-3 personer ved montasje av denne pergolaen /  
It is recommended to work with a minimum of 2-3 people /  
Es wird empfohlen die Montage mit 2-3 Personen durchzuführen*

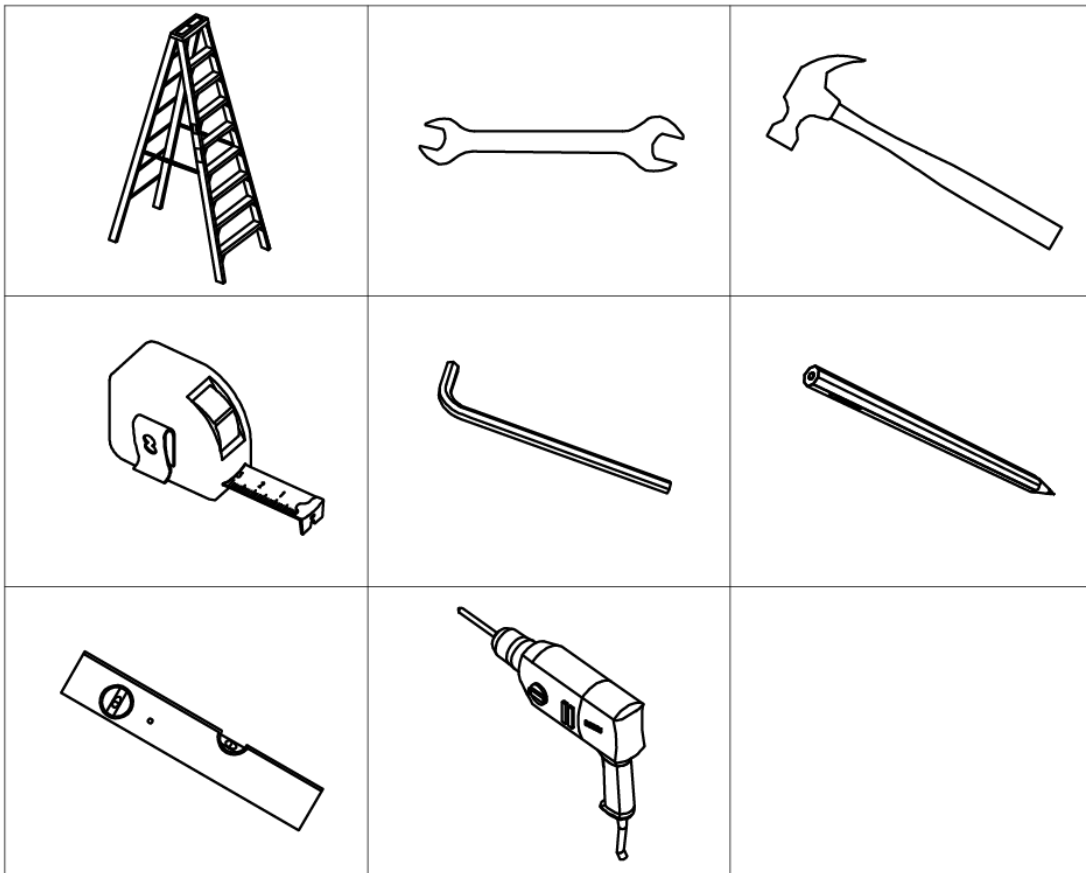
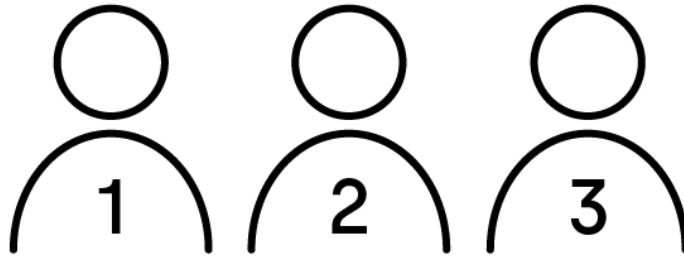

## Montering:

### Kjære kunde,





Gratulerer med ny pergola og takk for at du handler hos PERGOLUX. Før du starter monteringen er det viktig at du kontroller innholdslisten. Sjekk at innholdet i de enkelte pakkene er komplette. Vær oppmerksom på at noen skruer allerede er forhåndsmontert. Hvis emballasjen eller pergolaen har synlige skader, ta et bilde og kontakt oss omgående på [kundeservice@pergolux.no](mailto:kundeservice@pergolux.no) eller via chat på nettsiden.

Vi håper du var fornøyd med bestillingsprosessen og leveransen av produktet. Vi er opptatt av å kontinuerlig forbedre våre produkter og setter stor pris på tilbakemeldinger!

Lykke til med monteringen!

### Trinn 1:

Monter platene ②x4 til bunnen av søylene med ①x16 skruer med en elektrisk drill eller en sekskantnøkkel.

① x 16	
② x 4	
D1 x 2	
D2 x 2	

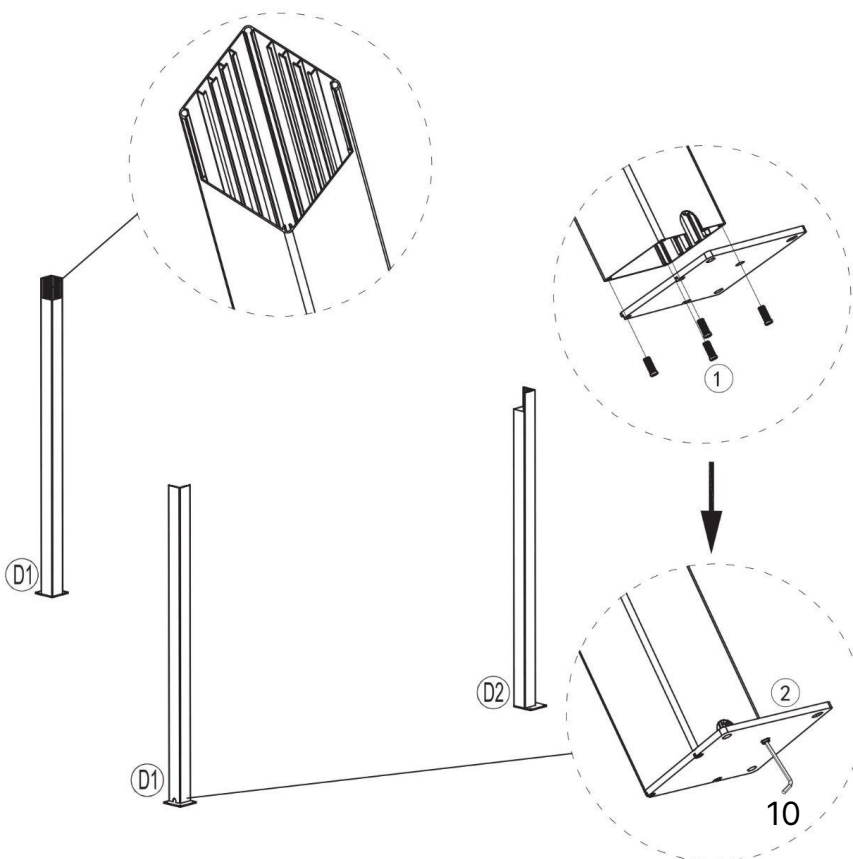

## Trinn 2:

Legg søylene (D1) og (D2) ned (pass på at søylene ikke blir ripet).

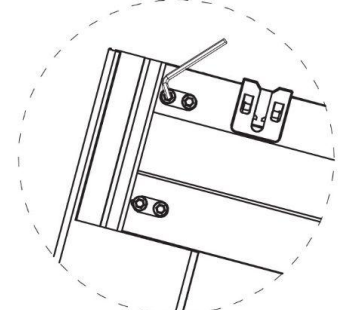
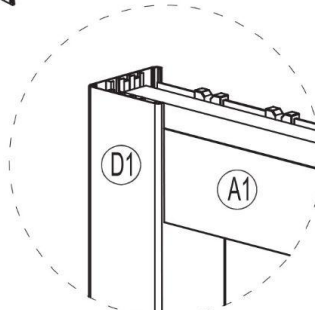
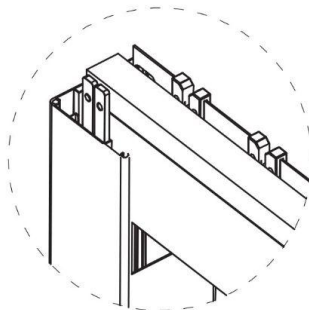
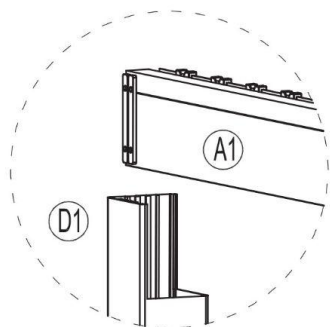
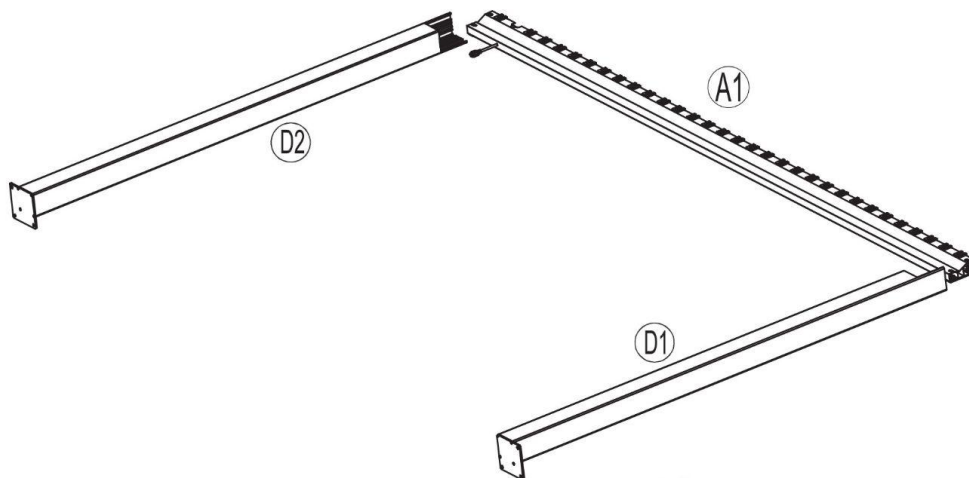
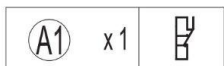

Monter bjelken (A1) fast til søylene. Legg merke til at skruene som skal benyttes for innfestning av bjelken allerede er skrudd fast til søylene. Disse må derfor løsnes før montering.

Benytt samme fremgangsmåte for bjelke (A2).



### Trinn 3:

Monter de resterende bjelkene og søylene i systematisk rekkefølge. Skru fast topp-platene ④ i alle hjørner med skruene ①, men vent med å stramme før bjelkene, søylene og takrennene (trinn 4) er montert.



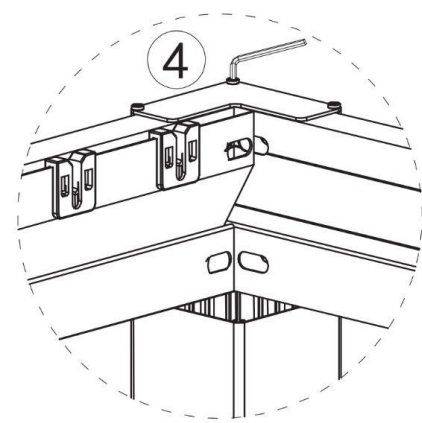
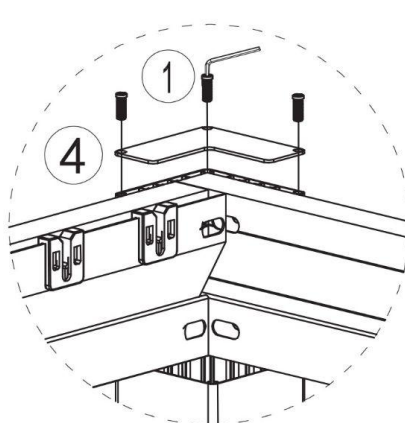
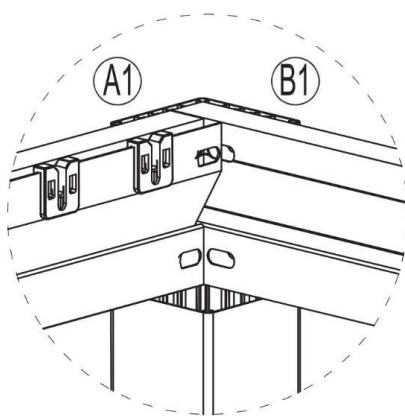
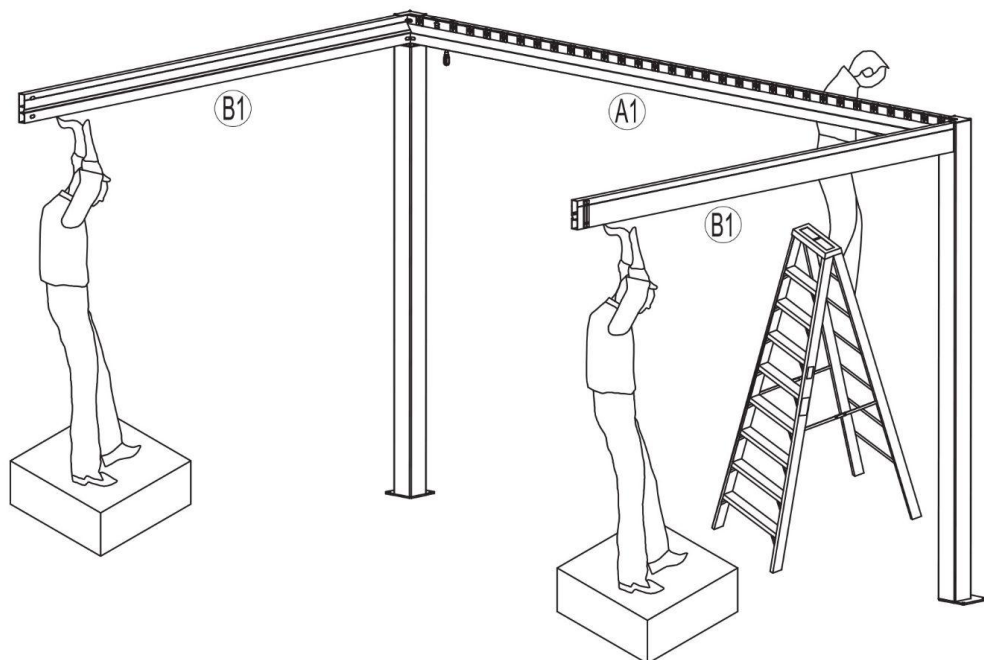

① x 6	
④ x 2	
B1 x 2	



## Trinn 4:

Skyv 2x(11) inn i takrennene (E1) og (F1) for montasje av tilleggsprodukter.

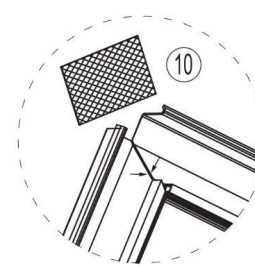
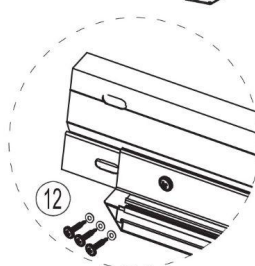
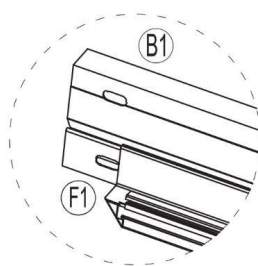
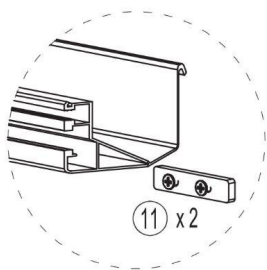
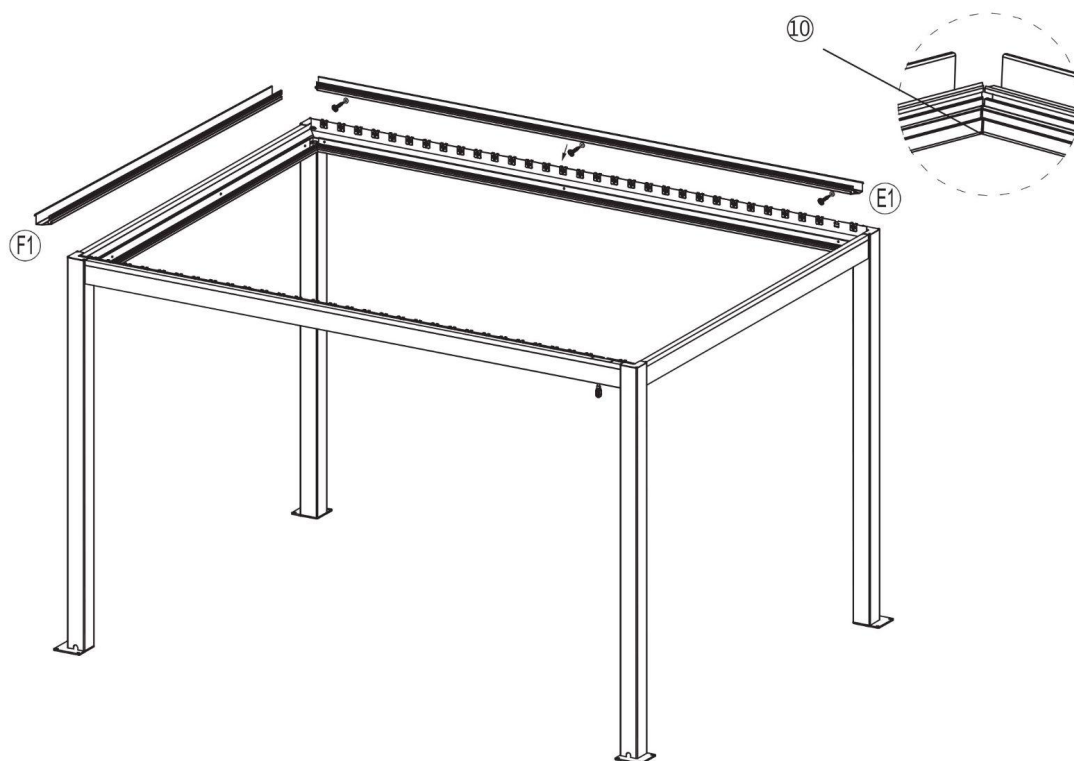

Heng takrennene på bjelkene som vist nedenfor og skru dem fast med skruer (12)

(E1) x2	
(F1) x2	
(11) x8	
(10) x4	
(12) x12	



## Trinn 5:

Stram til topp-platene med skruene ①.

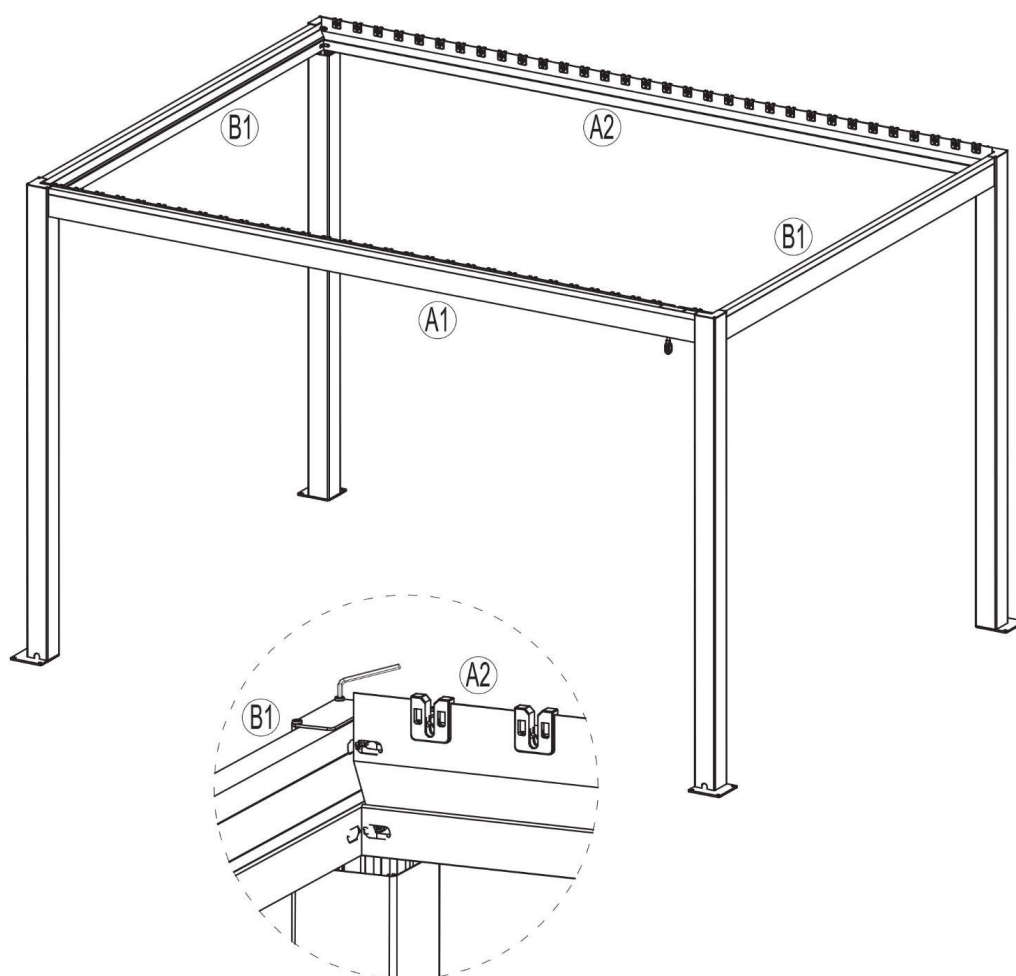

① x6	
③ x2	
A2 x1	



## Trinn 6:

Sett inn styrelamellen (H)x1 på den andre raden som vist nedenfor. Bruk gjerne litt kraft for å få den inn.

Monter deretter de andre lamellene i rekkefølge.



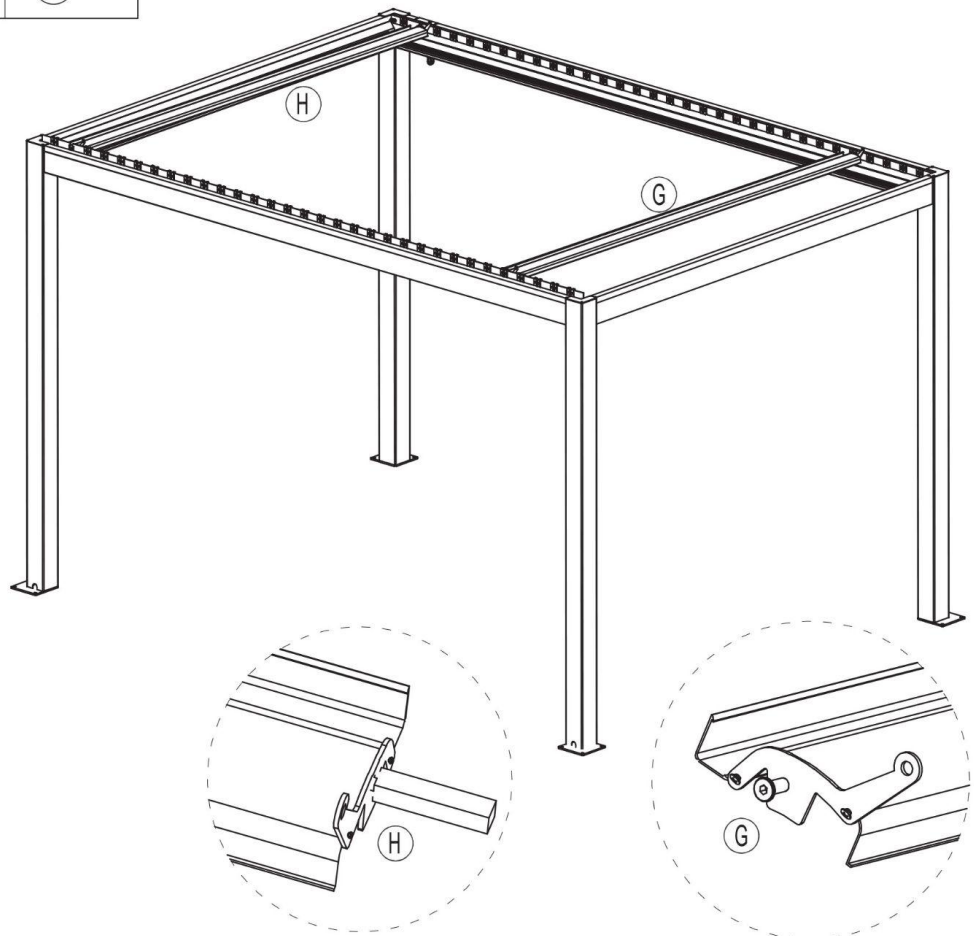

300X300		(H) X1	(G) X22
300X400		(H) X1	(G) X31
400X400		(H) X1	(G) X31



## Trinn 7:

Fest lamellene og styringsskinnen (J) med skruer (4), skiver (5) og muttere (6) som vist nedenfor.

Stram skruene til med en sekskantnøkkel.

				
300X300	④ X46	⑤ X46	⑥ X46	J X2
300X400	④ X64	⑤ X64	⑥ X64	J X2
400X400	④ X64	⑤ X64	⑥ X64	J X2

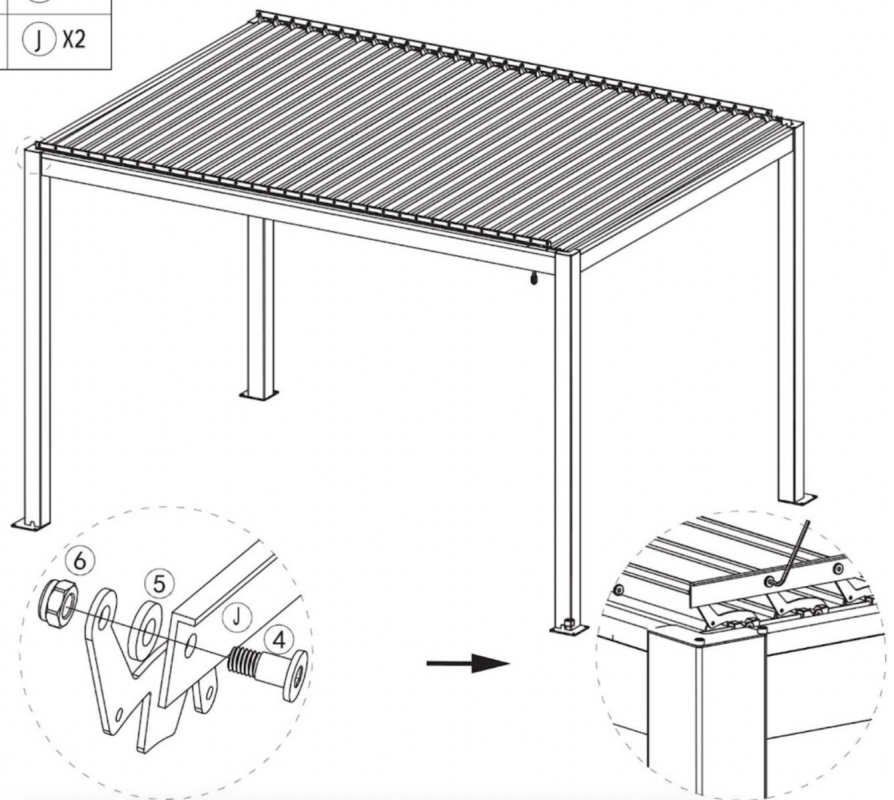





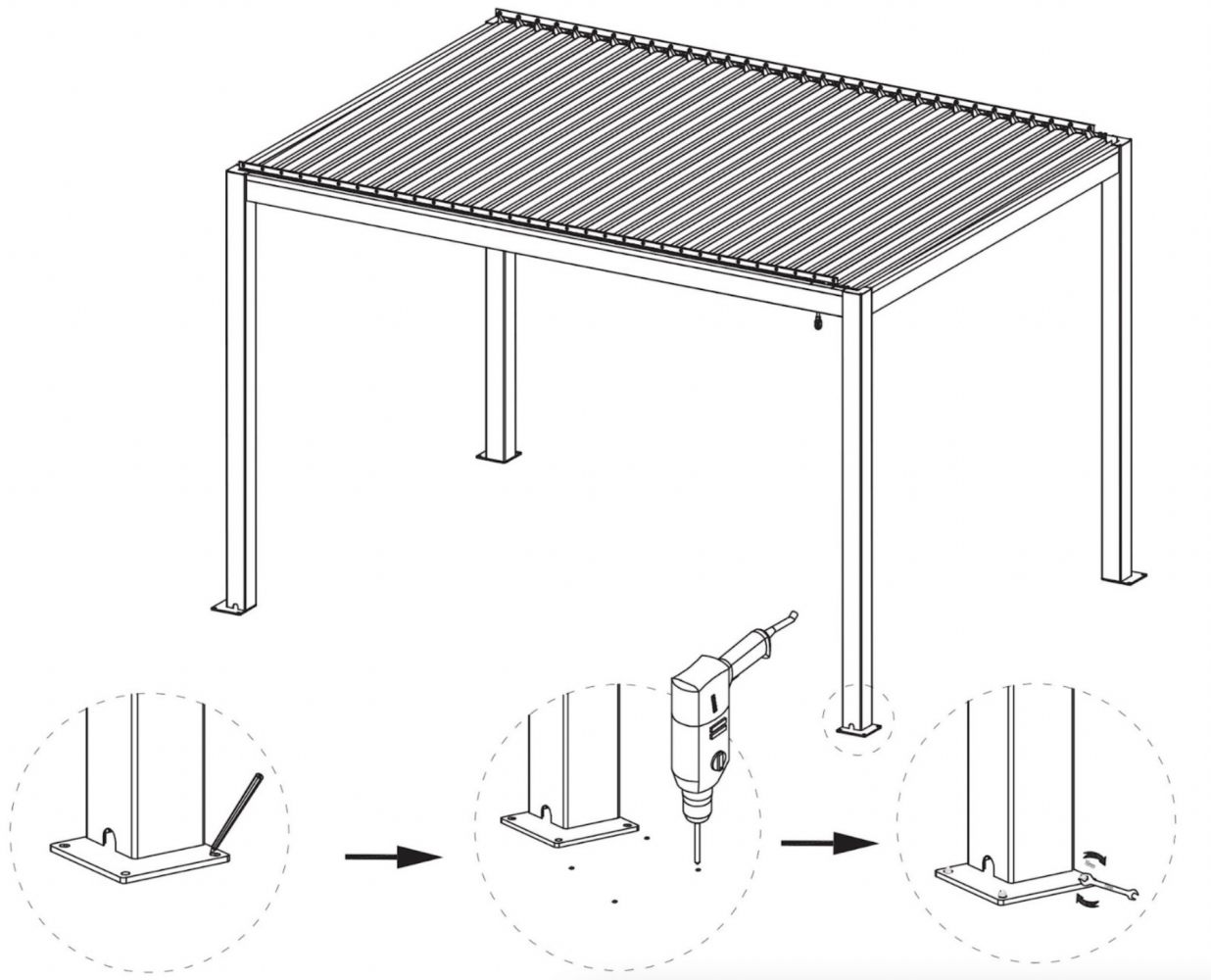

## Trinn 8:

Du kan nå feste pergolaen til underlaget. Egnede festemidler kan kjøpes hos din nærmeste byggevareforhandler. Påse at du ikke skrur igjennom membraner etc.



## Trinn 9:

Monter stormsikringsplatene ⑧ og ⑨ på bjelkene med skruer.

⑧ x2		x8	
⑨ x2		x8	

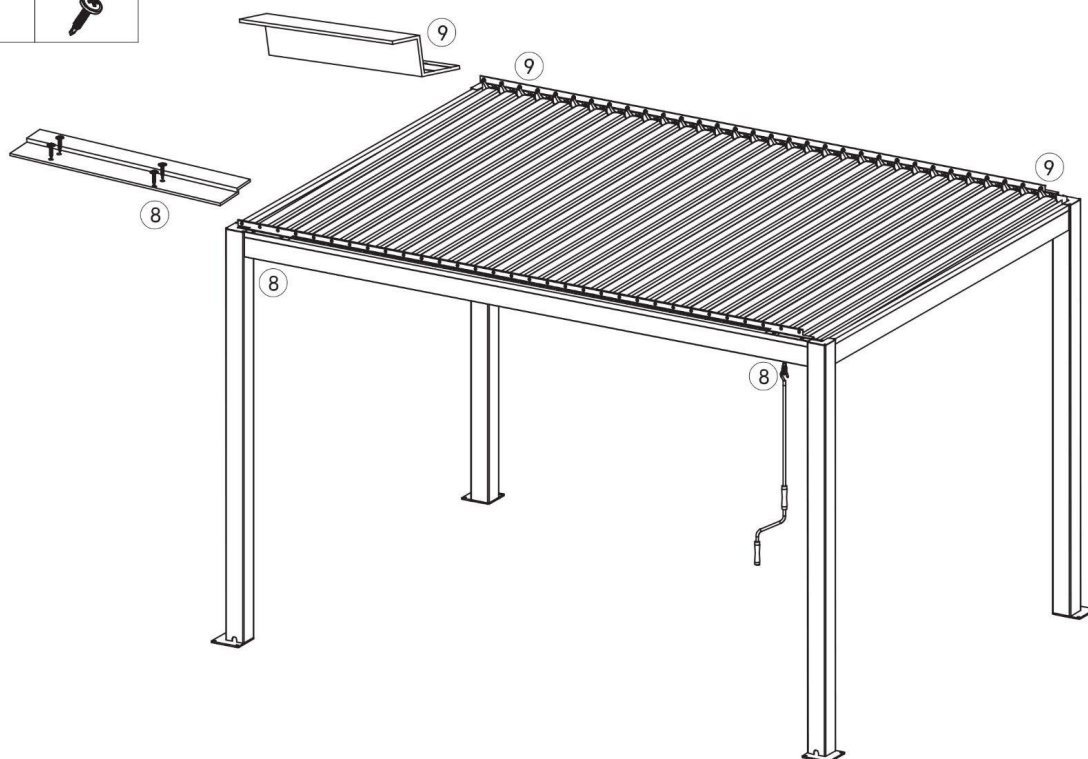

## Installation:

### Dear Customer,

Congratulations and thank you for choosing our PERGOLUX pergola.





Before you start assembling the pergola, use the product list to check that the individual packages are complete. Please note that some screws are already pre-assembled. If the packaging or the pergola has visible damage, take a picture of it and contact us immediately at [customerservice@pergolux.com](mailto:customerservice@pergolux.com) or via the chat on our website.

We hope you are satisfied with the ordering process, the delivery, the assembling instructions and the product itself. We want to continuously improve our service and product and we welcome your feedback!

Good luck with the assembling the product!

### Step 1:

Install the plates ②x4 to the bottom of the pillars with screws ①x16 using an electric drill or a hex key.

① x 16	
② x 4	
D1 x 2	
D2 x 2	

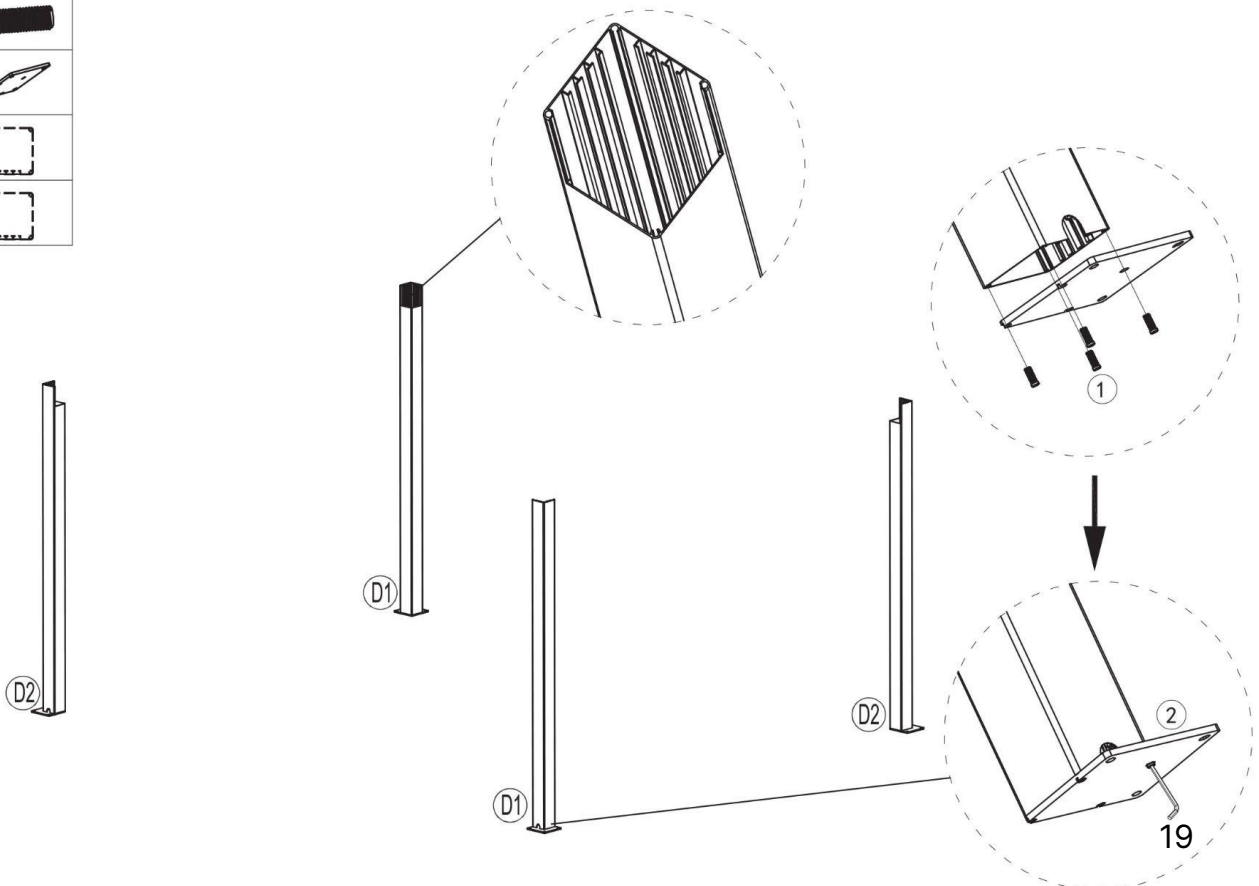

## Step 2:

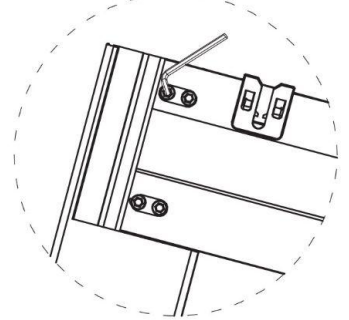
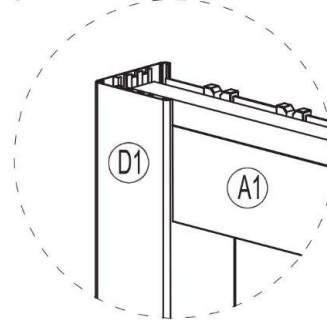
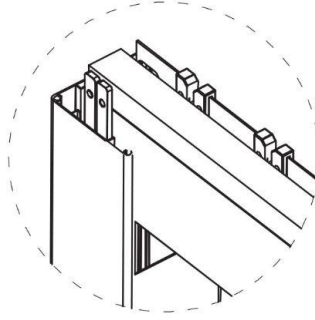
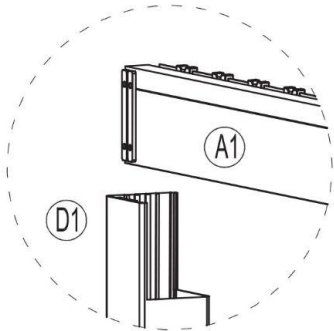
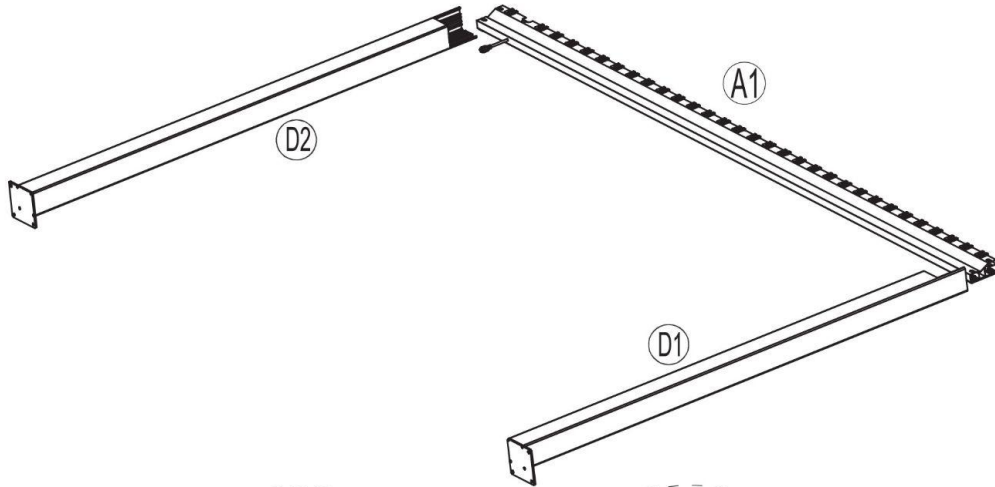
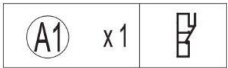

Lay the pillars (D1) and (D2) down and insert the beam (A1).

Repeat this process with (A2).



### Step 3:

Install the remaining beams and columns in systematic order. Screw the top-plates (4) on all corners with the screws (1) - do not tighten the screws until the beams, columns and gutters (step 4) are mounted.



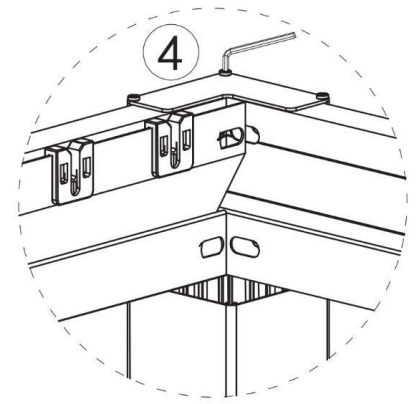
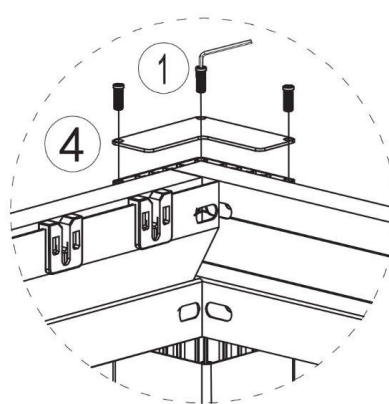
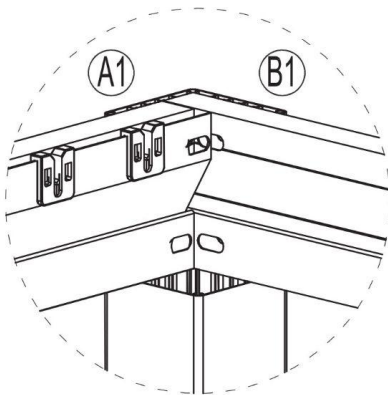
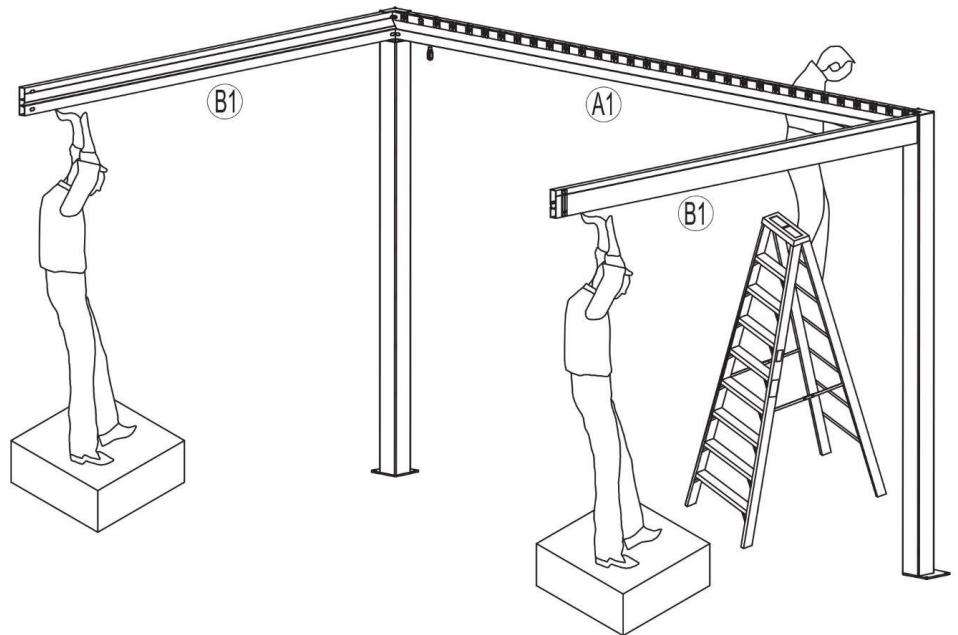

① x6	
④ x2	
B1 x2	



## Step 4:

Slide ⑪x2 into the gutters ①E1 and ①F1 for installing heaters.

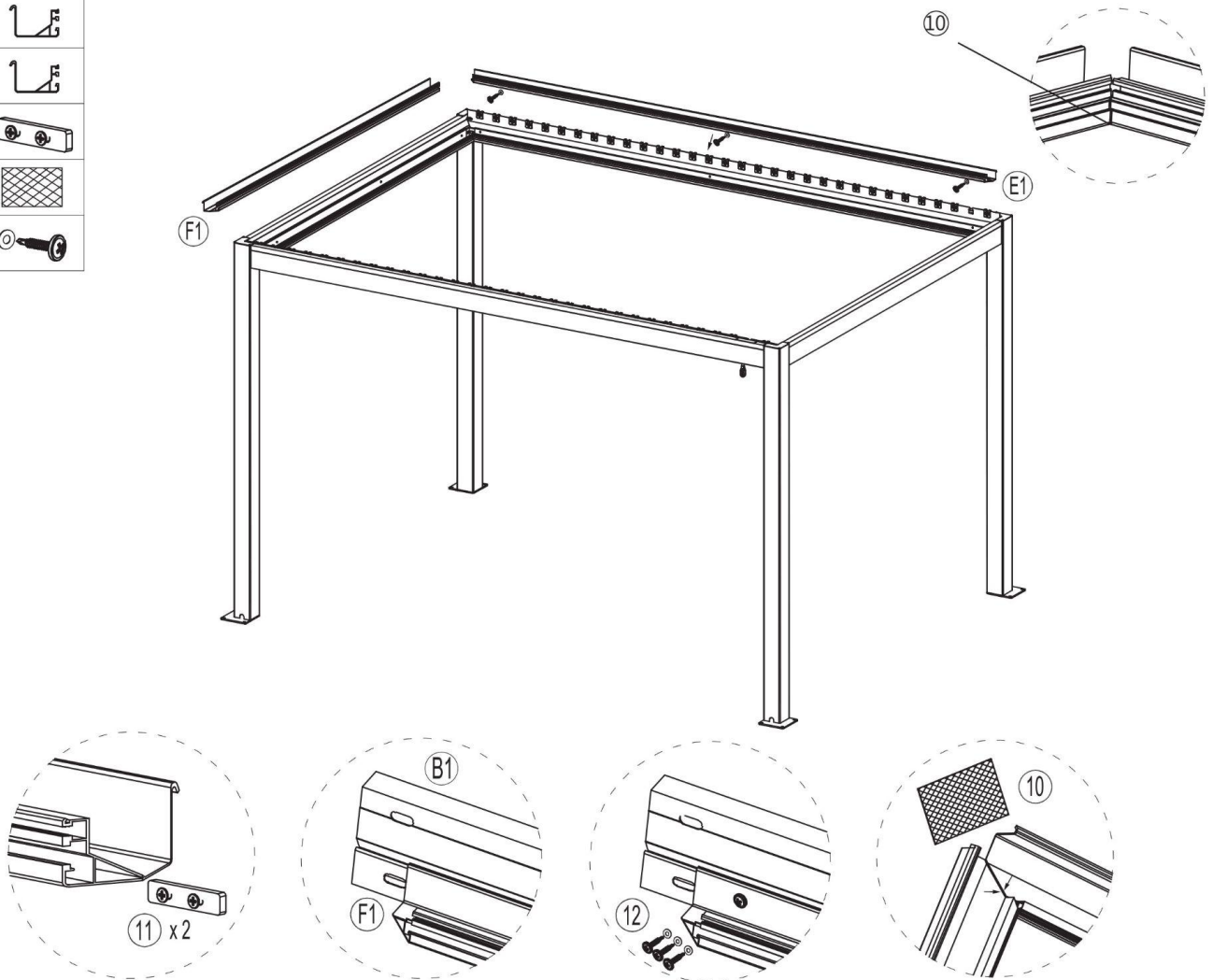

Hang the gutters onto the beams as seen below. Screw them onto the beam with screws ⑫.

①E1 x2	
①F1 x2	
①⑪ x8	
①⑩ x4	
①⑫ x12	



## Step 5:

Tighten the top-plates with screws ①.

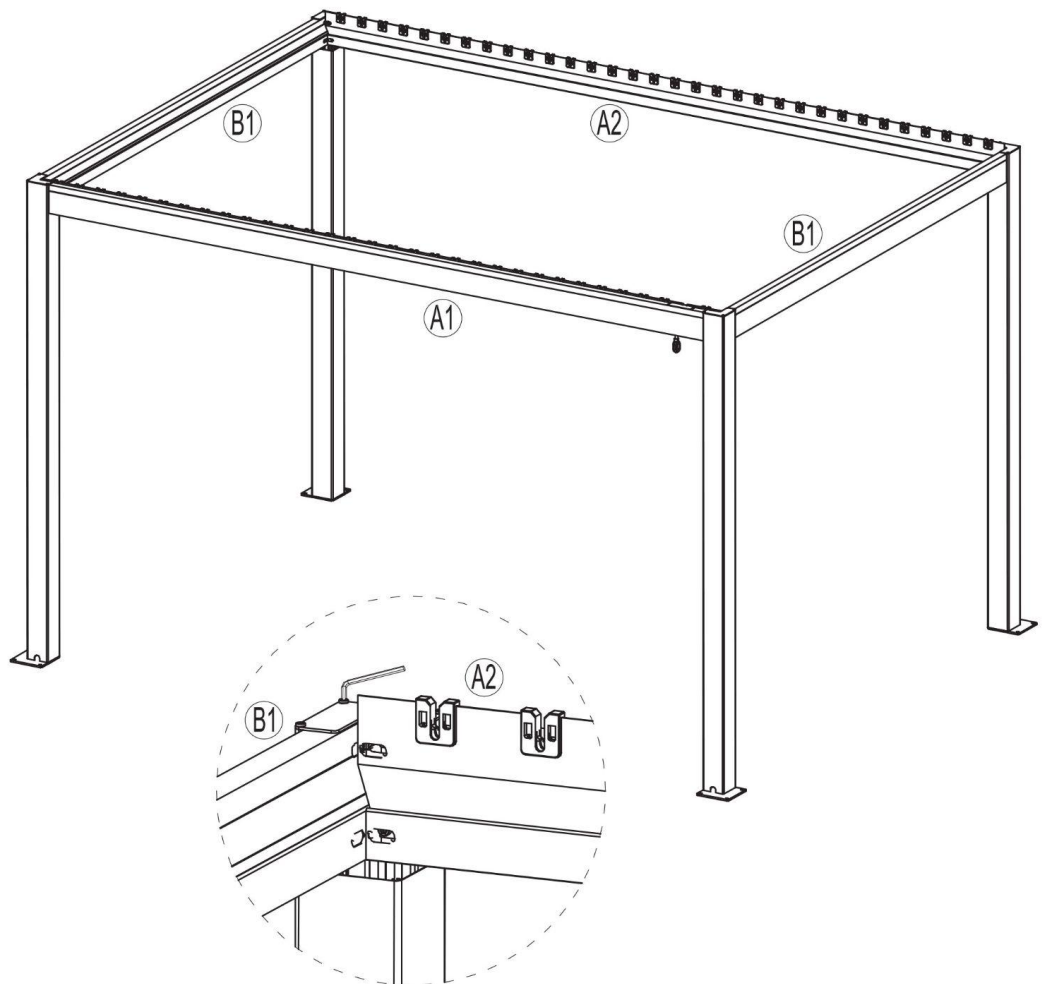

① x6	
③ x2	
A2 x1	



## Step 6:

Insert the steering slats (H)x1 on the second row.

Proceed by installing the other slats respectively.

300X300		(H) X1	(G) X22
300X400		(H) X1	(G) X31
400X400		(H) X1	(G) X31

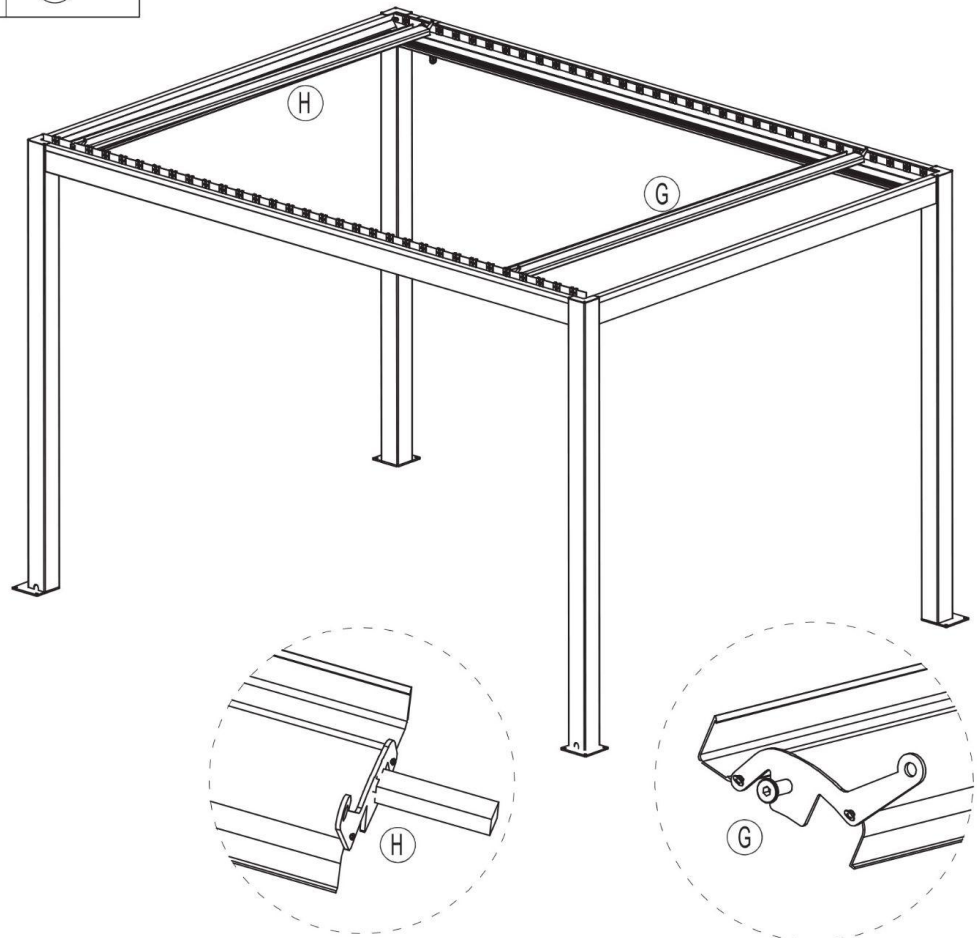







## Step 7:

Connect the slats and the steering rail (J) with (4) (5) (6) as seen below.

Continue by tightening the screws with a hex key.

				
300X300	(4) X46	(5) X46	(6) X46	(J) X2
300X400	(4) X64	(5) X64	(6) X64	(J) X2
400X400	(4) X64	(5) X64	(6) X64	(J) X2

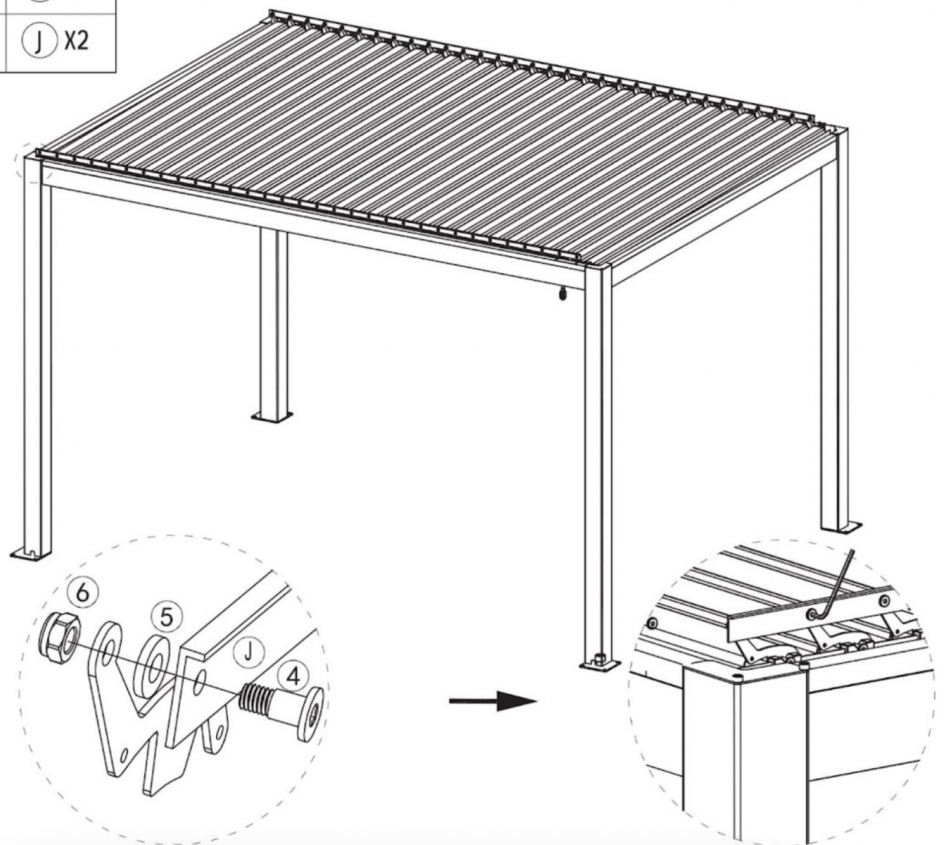



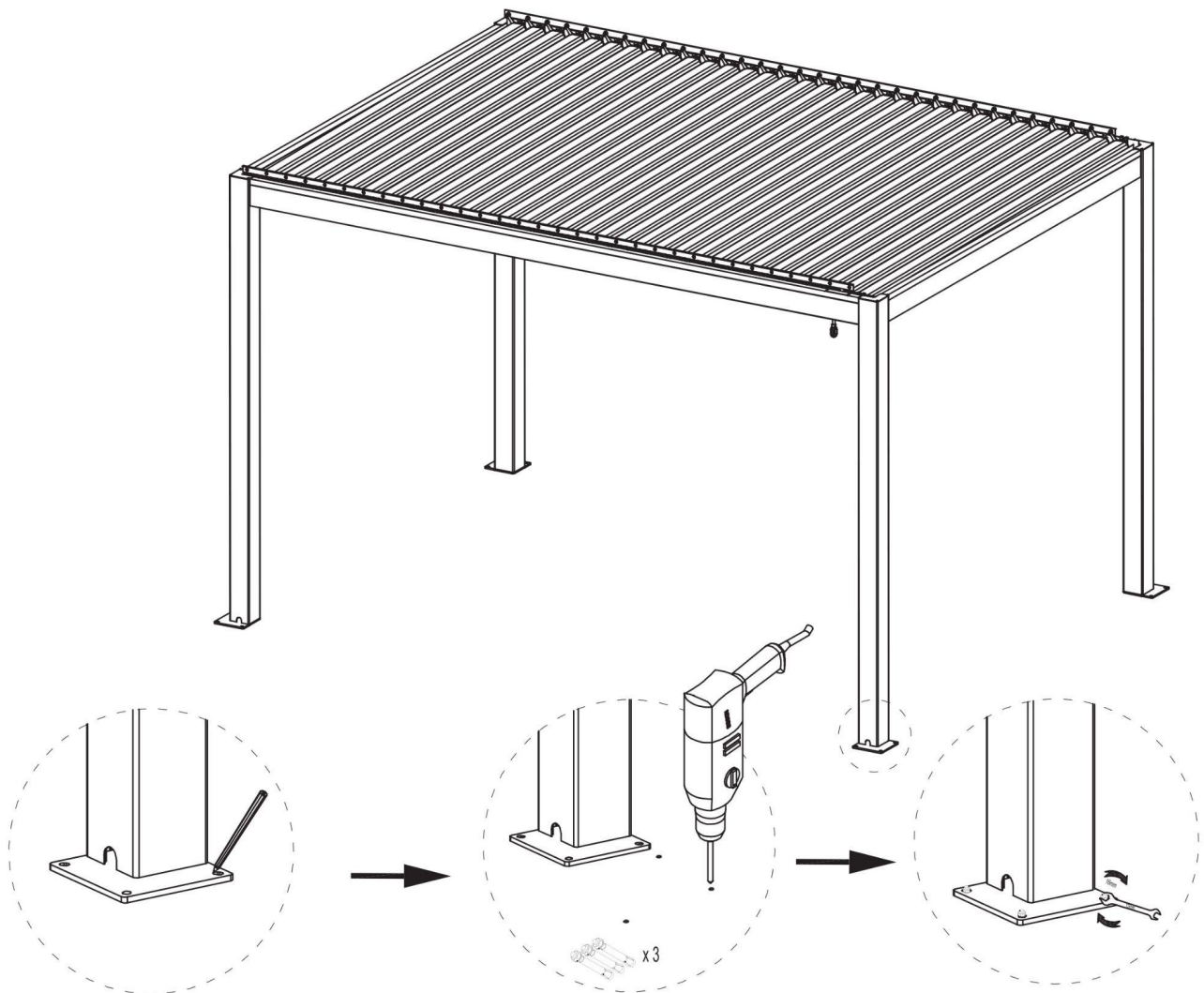

## Step 8:

You can now attach the pergola to the ground. Suitable fasteners can be purchased from a building materials dealer. Be careful not to screw through membranes etc.



## Step 9:

Install the wind protection plates (8) and (9) onto the beams with screws as shown below:

(8) x2		x8	
(9) x2		x8	

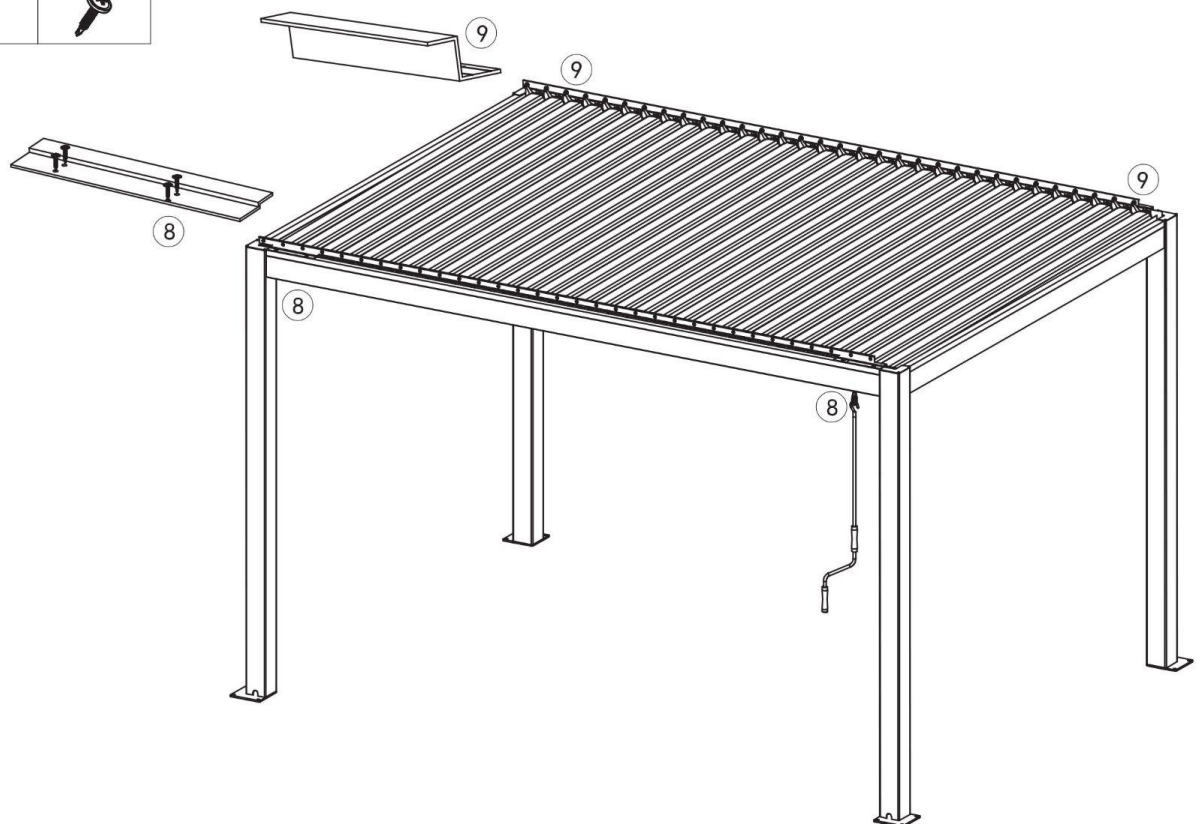

## Montage:

### Sehr geehrter Kunde,





herzlichen Glückwunsch und vielen herzlichen Dank, dass Sie sich für eine PERGOLUX Pergola entschieden haben. Bevor Sie mit der Montage beginnen, kontrollieren Sie anhand der Produktliste die einzelnen Pakete auf Ihre Vollständigkeit, bitte beachten Sie das bereits einige Schrauben vormontiert sind. Sollte die Verpackung oder die Pergola sichtbare Schäden haben, dann fotografieren Sie diese und kontaktieren Sie uns umgehend unter [kundenservice@pergolux.de](mailto:kundenservice@pergolux.de) oder über den Chat auf der Webseite.

Wir hoffen, Sie waren mit dem Bestellvorgang, der Anlieferung, der Montage und dem Produkt äußerst zufrieden. Wir möchten uns stetig verbessern und sind sehr an Ihrer Rückmeldung interessiert.

Viel Erfolg bei der Montage wünscht ihr PERGOLUX Team!

### Schritt 1:

Installieren sie die Grundplatten (2)x4 an der Unterseite der Säule mit den Schrauben (1)x16 ziehen sie die Schrauben fest.

① x 16	
② x 4	
ⓓ1 x 2	
ⓓ2 x 2	

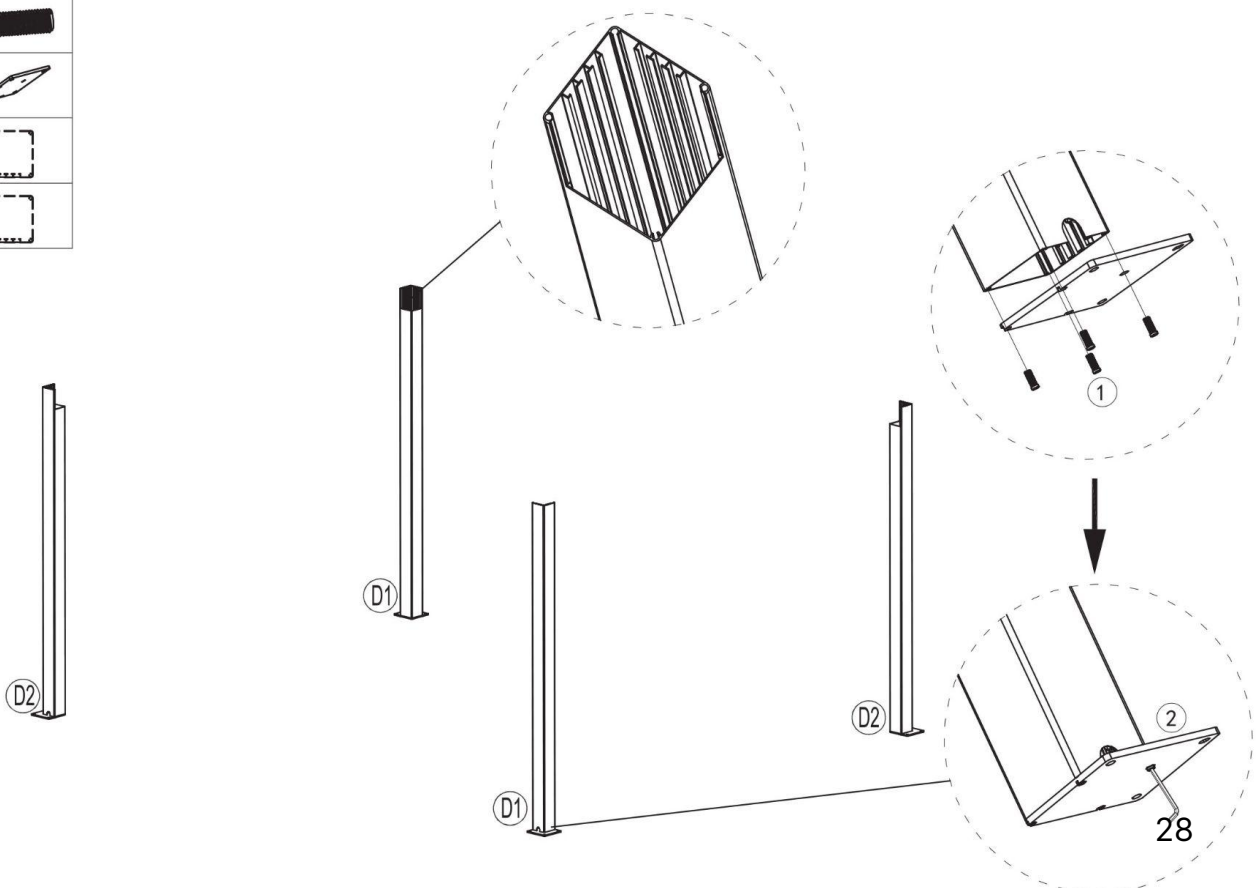

## Schritt 2:

Legen sie die Säulen (D1) und (D2) hin und setzen sie den Dachbalken (A1) ein

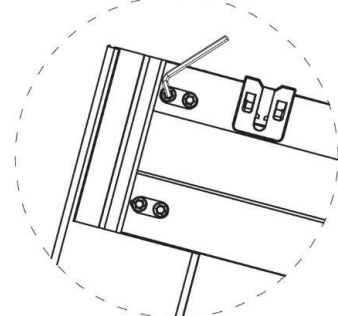
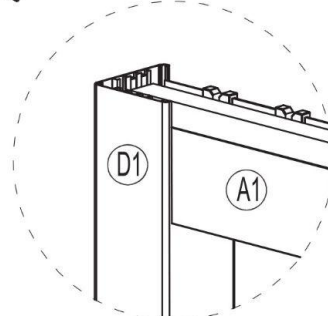
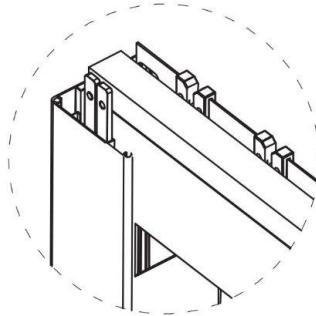
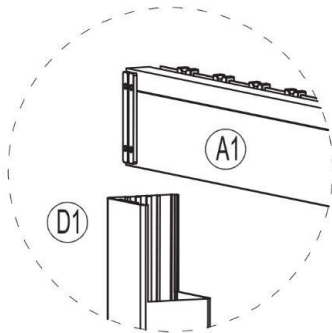
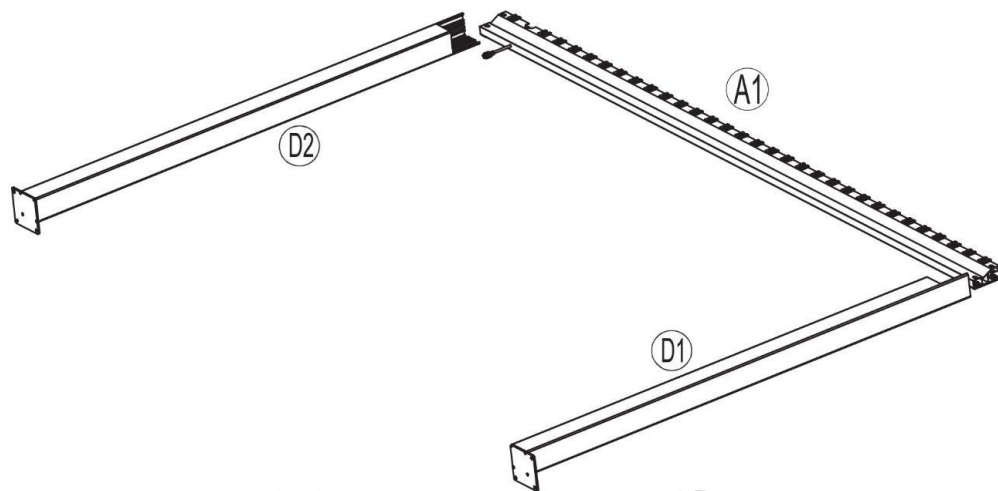
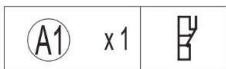

Machen Sie das Gleiche mit dem Dachbalken (A2).



### Schritt 3:

Montieren sie die restlichen Stützen und Balken der Reihe nach. Verschrauben sie die Deckplatten (4) an allen Ecken mit den Schrauben (1)

Ziehen sie die Schrauben erst fest, wenn die Balken, Säulen und Dachrinnen (Schritt 4) montiert sind.

① x 6	
④ x 2	
ⓑ1 x 2	

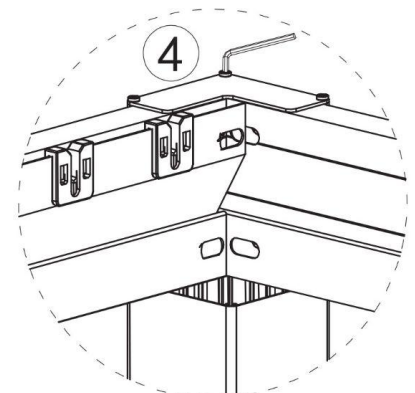
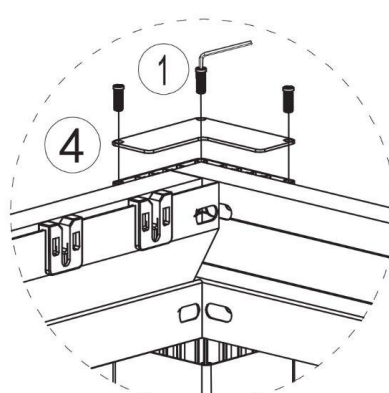
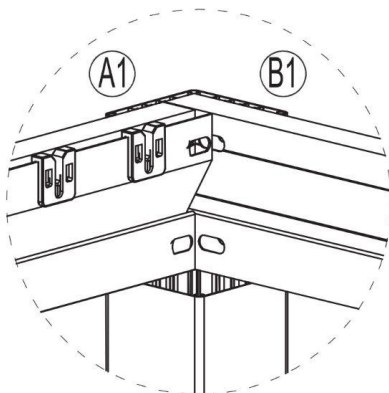
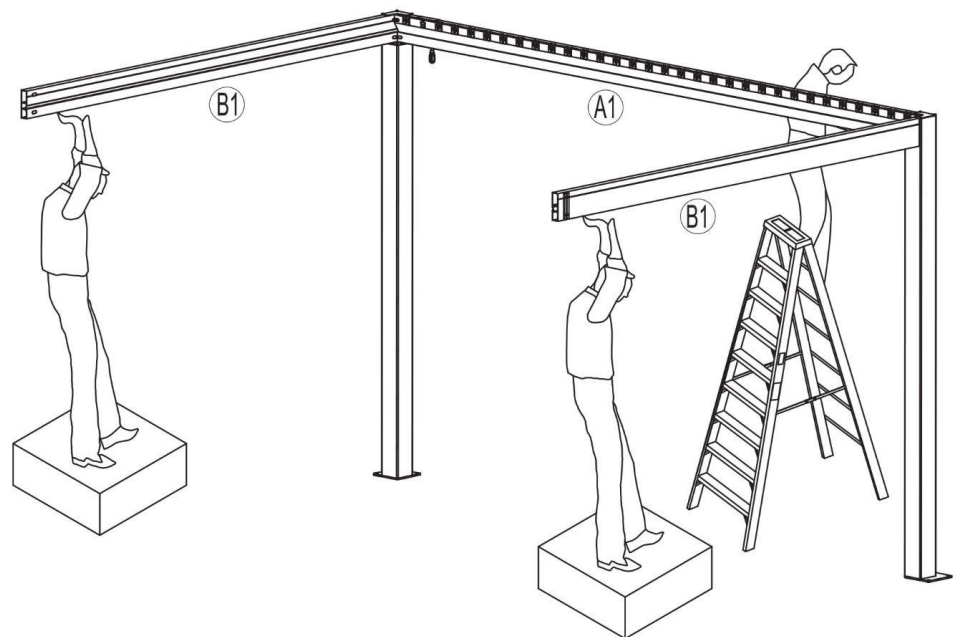



## Schritt 4:

⑪x2 in die Dachrinnen ①E1 und ①F1 einsetzen um Wärmelampen zu montieren.

Hängen sie die Dachrinnen, wie unten dargestellt, an die Balken.



Befestigen Sie sie an den Balken mit den Schrauben ⑫

①E1 x2	
①F1 x2	
⑪ x8	
⑩ x4	
⑫ x12	

31

## Schritt 5:

Ziehen sie die oberen Platten mit den Schrauben ① fest.

① x6	
③ x2	
A2 x1	

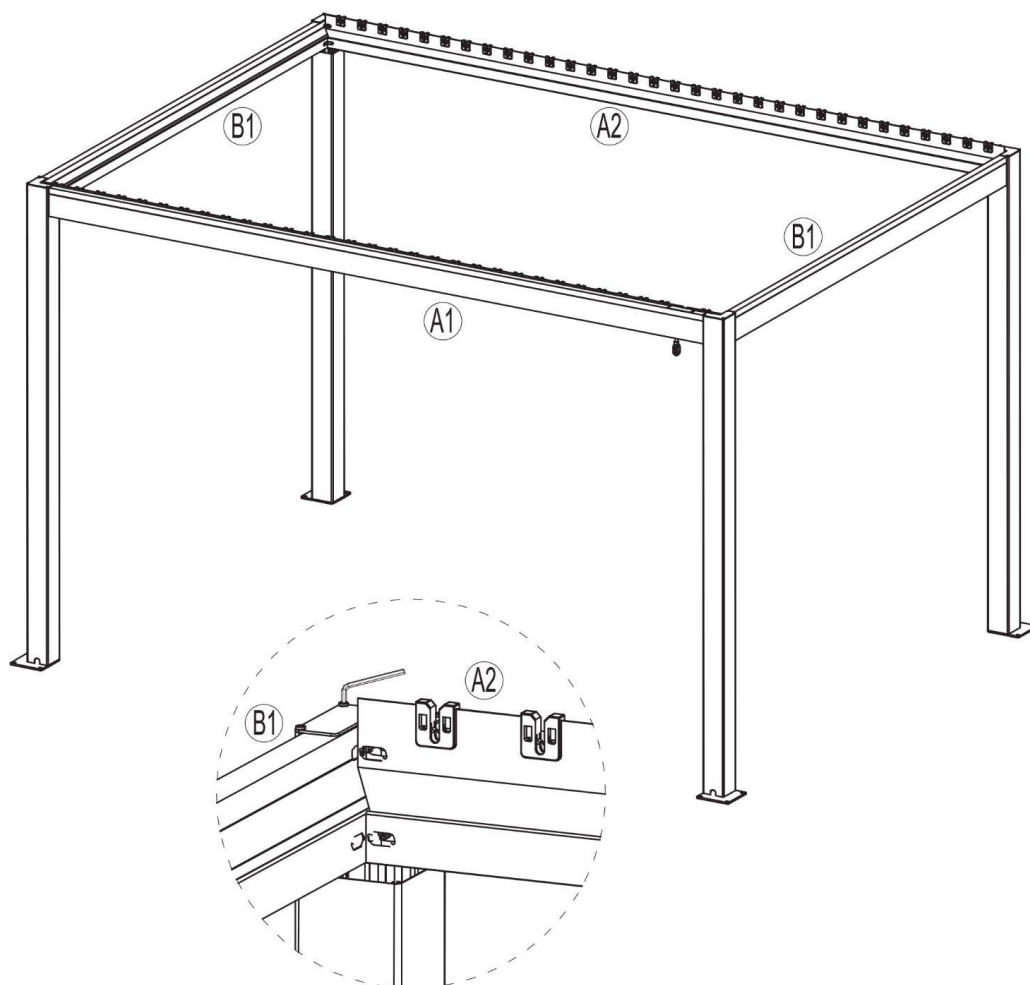





## Schritt 6:

Setzen sie die Steuerlamellen (H)x1 in der zweiten Reihe ein.

Danach installieren sie die restlichen Lamellen der Reihe nach.



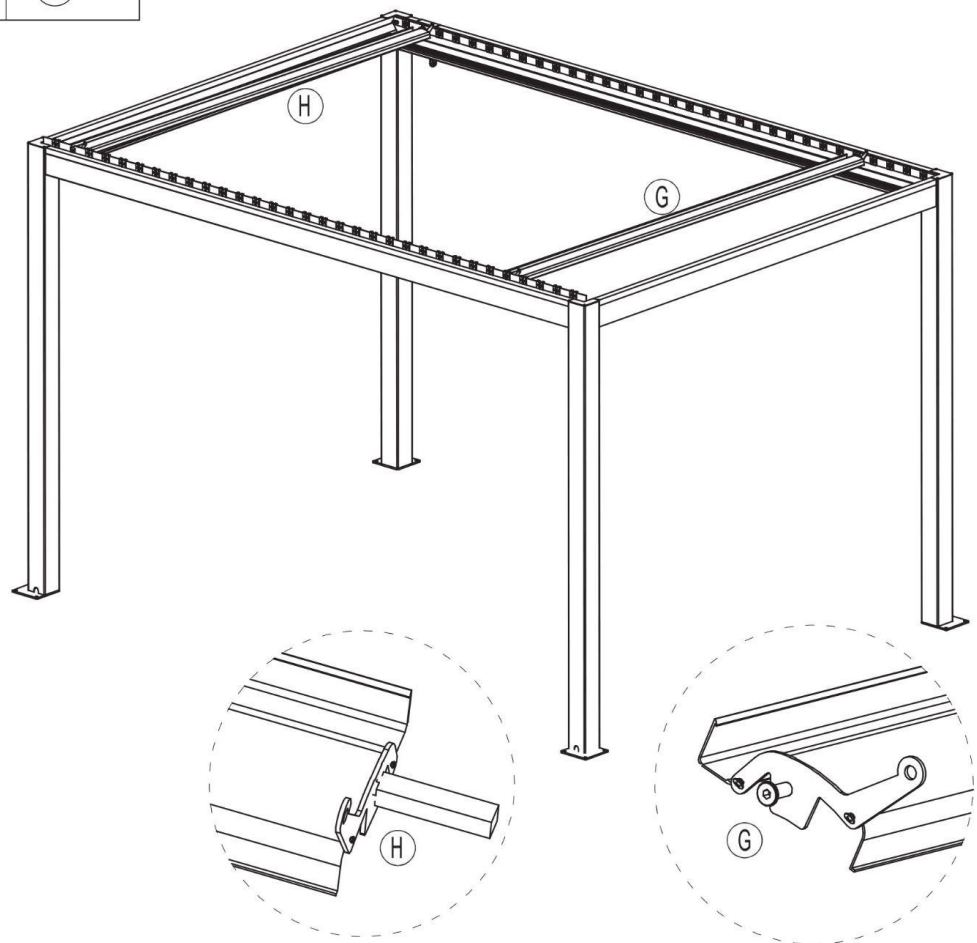

300X300		(H) X1	(G) X22
300X400		(H) X1	(G) X31
400X400		(H) X1	(G) X31



## Schritt 7:

Verbinden sie die Lamellen und die Lenkschienen (J) mit (4) (5) (6) wie unten abgebildet.

Fahren sie fort indem sie alle Schrauben festziehen.

				
300X300	(4) X46	(5) X46	(6) X46	(J) X2
300X400	(4) X64	(5) X64	(6) X64	(J) X2
400X400	(4) X64	(5) X64	(6) X64	(J) X2

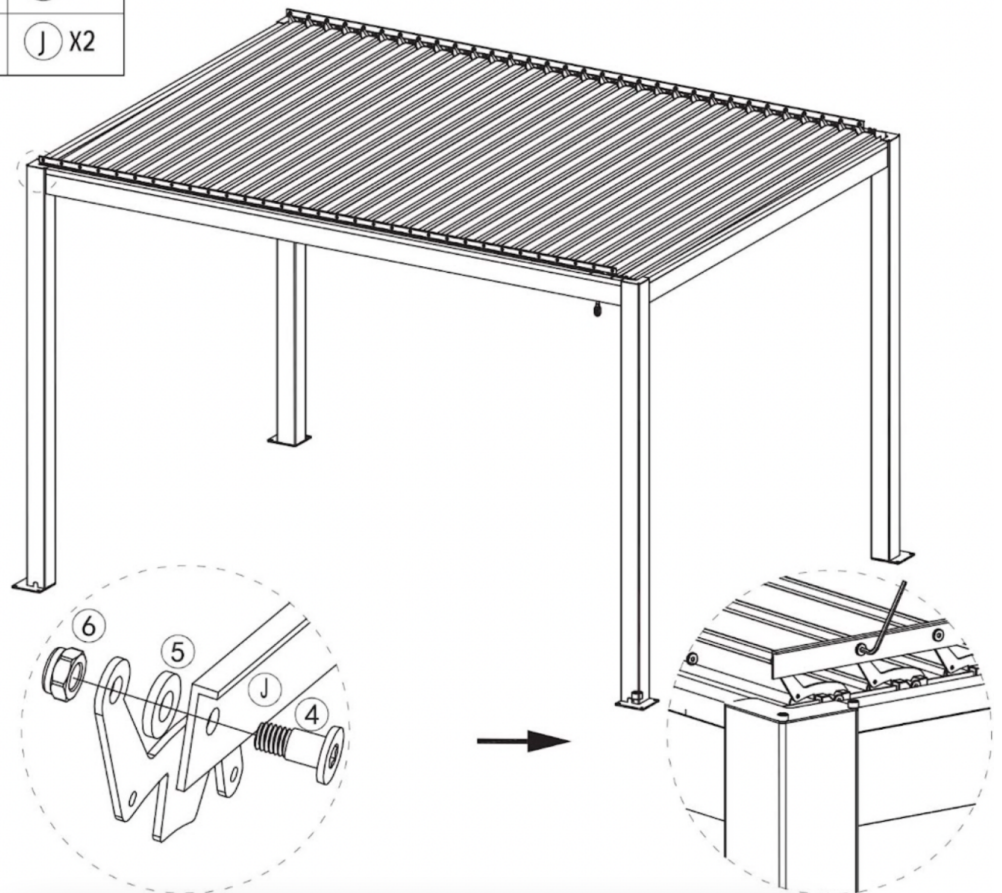



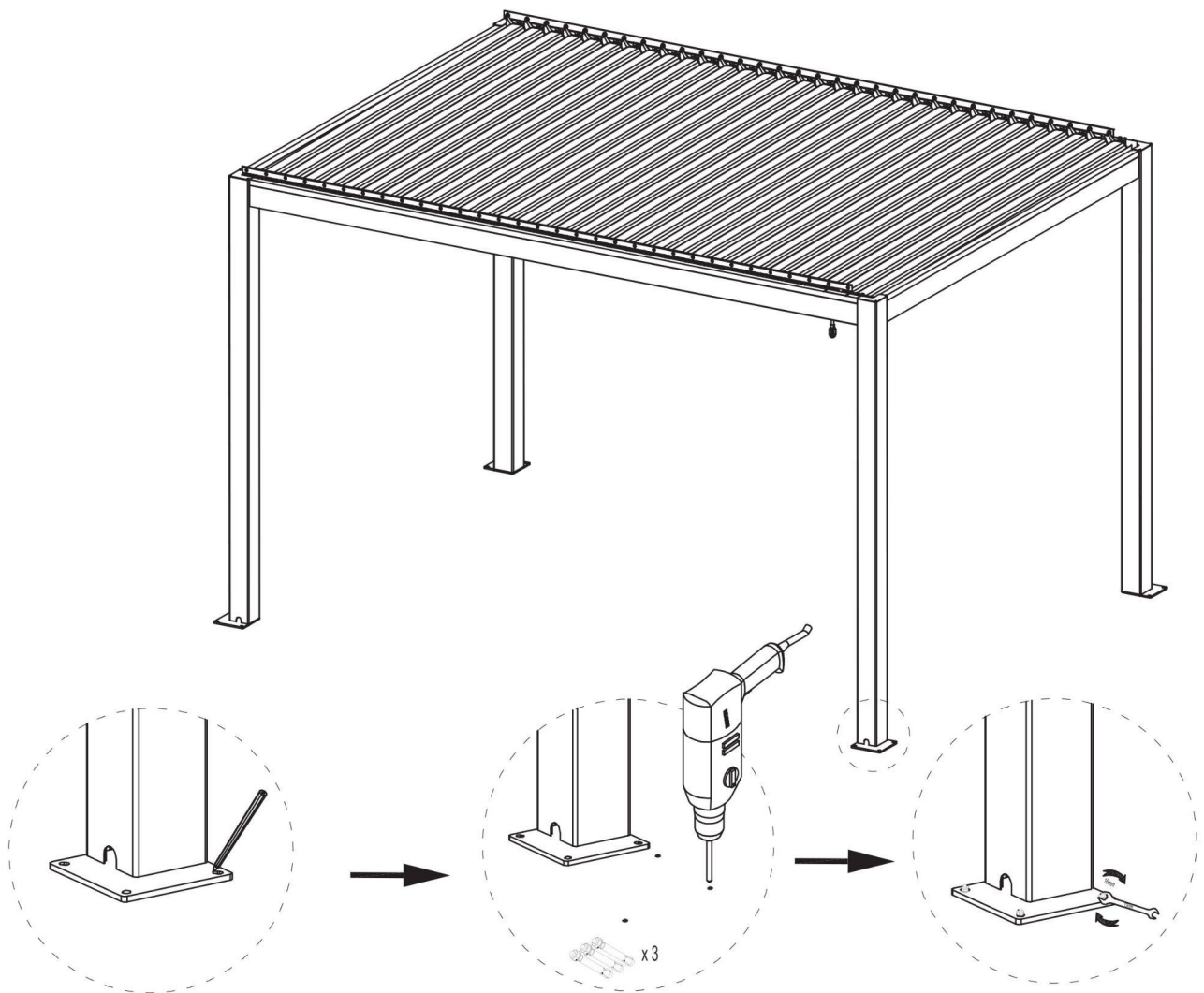

## Schritt 8:

Nun können sie die Pergola am Boden befestigen. Geeignete Befestigungsmittel sind im Baumarkt zu erwerben. Achten sie darauf nicht durch Membranen usw. zu schrauben.



## Schritt 9:

Montieren sie die Windschutzplatten ⑧ und ⑨ mit den Schrauben an den Trägern wie unten abgebildet.

⑧ x2		x8	
⑨ x2		x8	

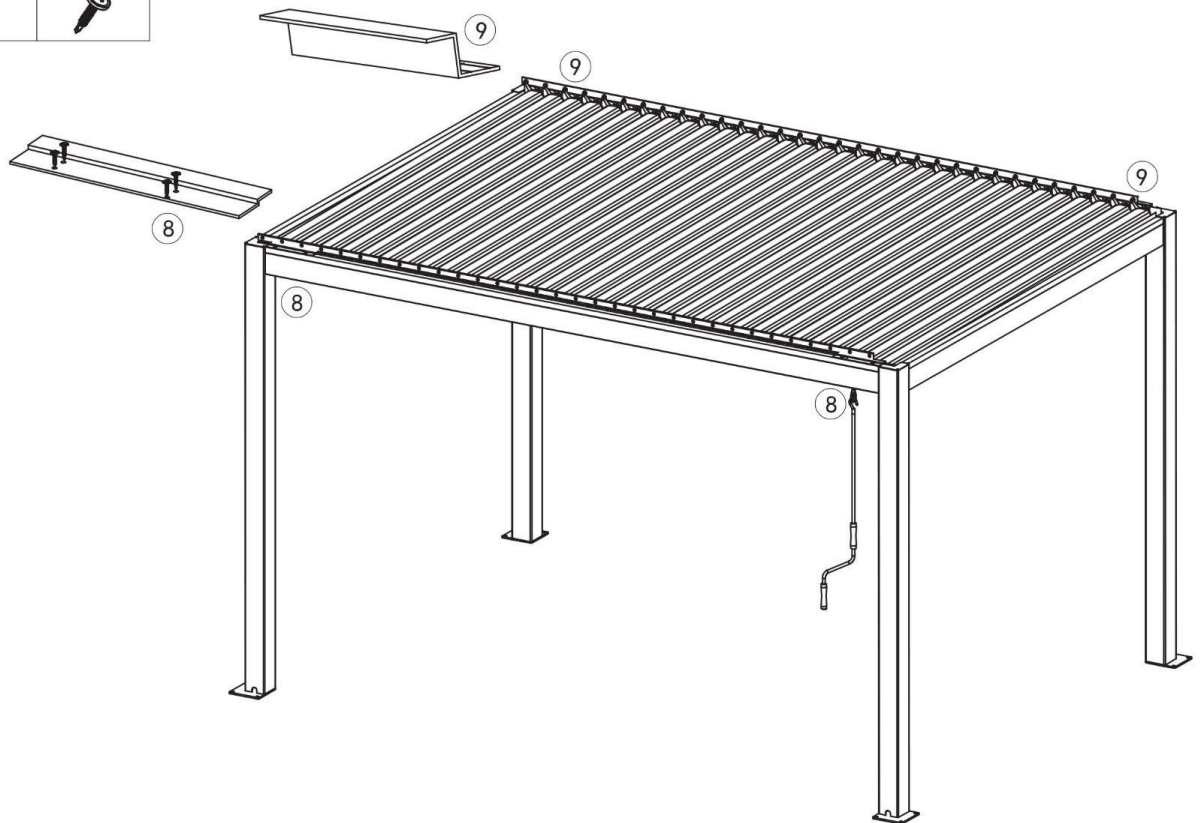

## **Sikkerhetsinstruksjoner / Security Instructions / Sicherheitshinweise:**

For alles sikkerhet er det viktig å følge instruksjonene nedenfor.

Ikke monter denne pergolaen selv, men kontakt en fagkyndig for hjelp dersom:

- du er usikker på om pergolaen kan monteres på stedet du har valgt for montasje.
- du forstår ikke bruksanvisningen eller deler av den.
- du ikke har de nødvendige verktøyene tilgjengelig.

Ikke monter pergolaen når du finner ødelagte deler eller deler som mangler. Skulle dette være tilfelle - kontakt oss omgående på [kundeservice@pergolux.no](mailto:kundeservice@pergolux.no)

////

For the safety of all it is very important to follow the instructions below

Do not assemble this pergola yourself, but contact a professional for help if:

- you are unsure if the pergola can be assembled in the place you have chosen for installation.
- you do not understand the instruction manual or parts of it.
- you do not have the necessary tools available.

Do not install the pergola when you find damaged parts or parts that are missing. Contact us immediately at [customerservice@pergolux.com](mailto:customerservice@pergolux.com) if this is the case.

////

Für ihre Sicherheit und die von anderen, ist es sehr wichtig die folgenden Anweisungen zu befolgen.

Montieren Sie die Pergola nicht selbst, sondern wenden sich an einen Fachmann wenn:

- Sie sich nicht sicher sind, ob die Pergola an dem von ihnen gewählten Standort montiert werden kann.
- Sie die Montageanleitung, oder Teile davon, nicht verstehen.
- Sie nicht die notwendigen Werkzeuge zur Verfügung haben.

Montieren Sie die Pergola nicht, wenn Sie beschädigte oder fehlende Teile bemerken. Sollte dies der Fall sein, kontaktieren sie uns umgehend unter [kundenservice@pergolux.de](mailto:kundenservice@pergolux.de)

### **Avslutende ord fra Pergolux-teamet**

Gratulerer med ferdig montert pergola! Nå har du forbrent noen kalorier og fortjener virkelig å slappe av under Pergolux-pergolaen. Vi håper du var fornøyd med bestillingsprosessen, leveringen, monteringen og selve produktet. Vi ønsker å kontinuerlig forbedre oss og er veldig interessert i dine tilbakemeldinger på nettsiden vår.

Vi ønsker deg mange flotte øyeblikk under din nye Pergolux pergola.

Varme og solfylte hilsener, Pergolux-teamet ditt

### **Schlussworte vom Team Pergolux**

Herzlichen Glückwunsch zur komplett montierten Pergola! Jetzt haben Sie einige Kalorien verbrannt und haben es verdient, unter der Pergolux Pergola richtig zu entspannen. Wir hoffen, Sie waren mit dem Bestellvorgang, der Anlieferung, der Montage und dem Produkt richtig zufrieden. Wir möchten uns laufend verbessern und sind sehr an einer Rückmeldung über unsere Webseite interessiert.

Wir wünschen Ihnen viele schöne Momente unter Ihrer neuen Pergolux Pergola.

Warme und sonnige Grüße, Ihr Pergolux Team

***Closing remarks from the Pergolux team***

Congratulations on the assembled pergola! You have now burned some calories and really deserve to relax under the Pergolux pergola. We hope that you were satisfied with the ordering process, the delivery, the assembly and the product itself. We want to continuously improve and are very interested in your feedback.

We wish you many wonderful moments under your new Pergolux pergola.

Warm and sunny greetings, Your Pergolux team

  
Johannes

  
Erich

  
Henrik

  
Marielle

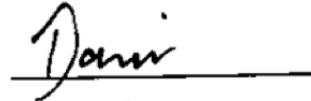
  
Dani

  
Henry

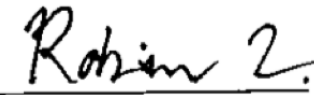
  
Robin

  
Sofie

  
Lucas

  
Alexander

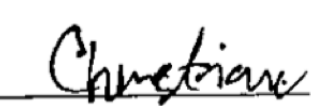
  
Christian

  
Sascha

  
Elin

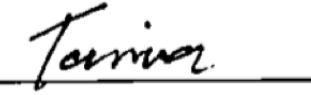
  
Tamina