

LOUVER
DRAIN
SLOPE

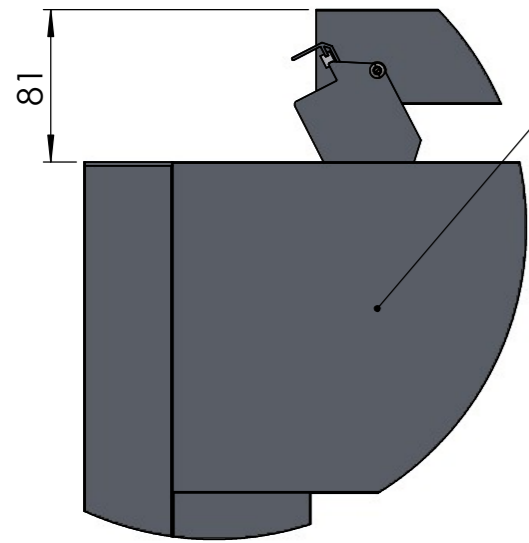

DETAIL A
OPEN POSITION

BEAM THICKNESS: 1,8

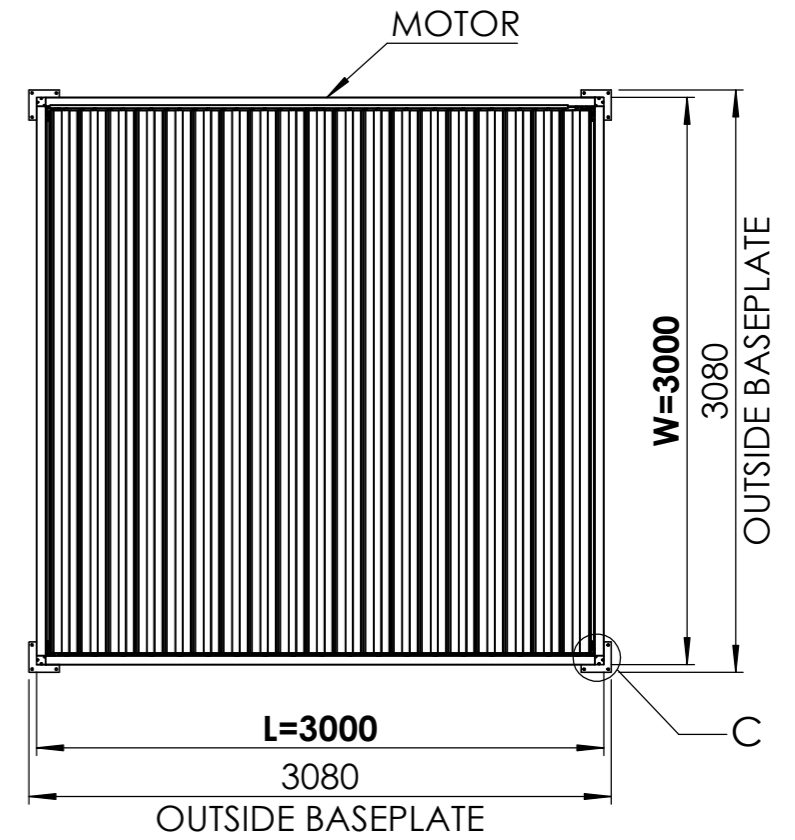
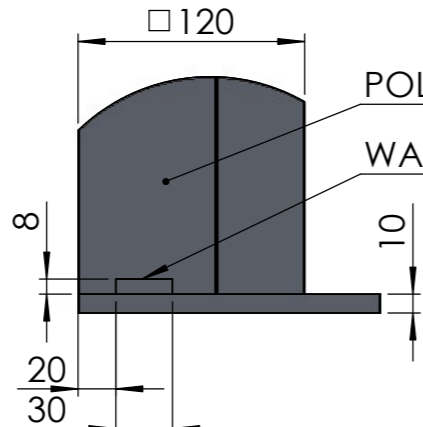

DETAIL B

LOUVER THICKNESS: 1,5

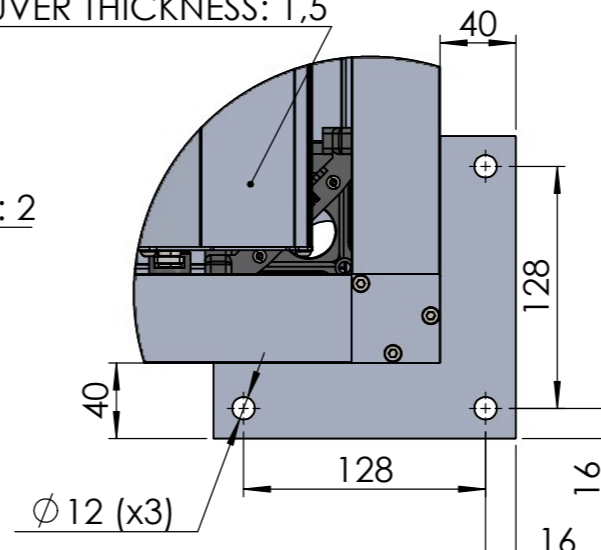

DETAIL C

PERGOLUX

TITLE:
P. PERGOLA V2 3X3 FREESTANDING

WEIGHT:
173kg

SKU:
PER_MA_XXX_3X3_FRE_02

PART NUMBER:
PN-200000724

REVISION
V2.1

DO NOT SCALE DRAWING ALL DIMENSIONS ARE IN MILLIMETERS SHEET 1 OF 2

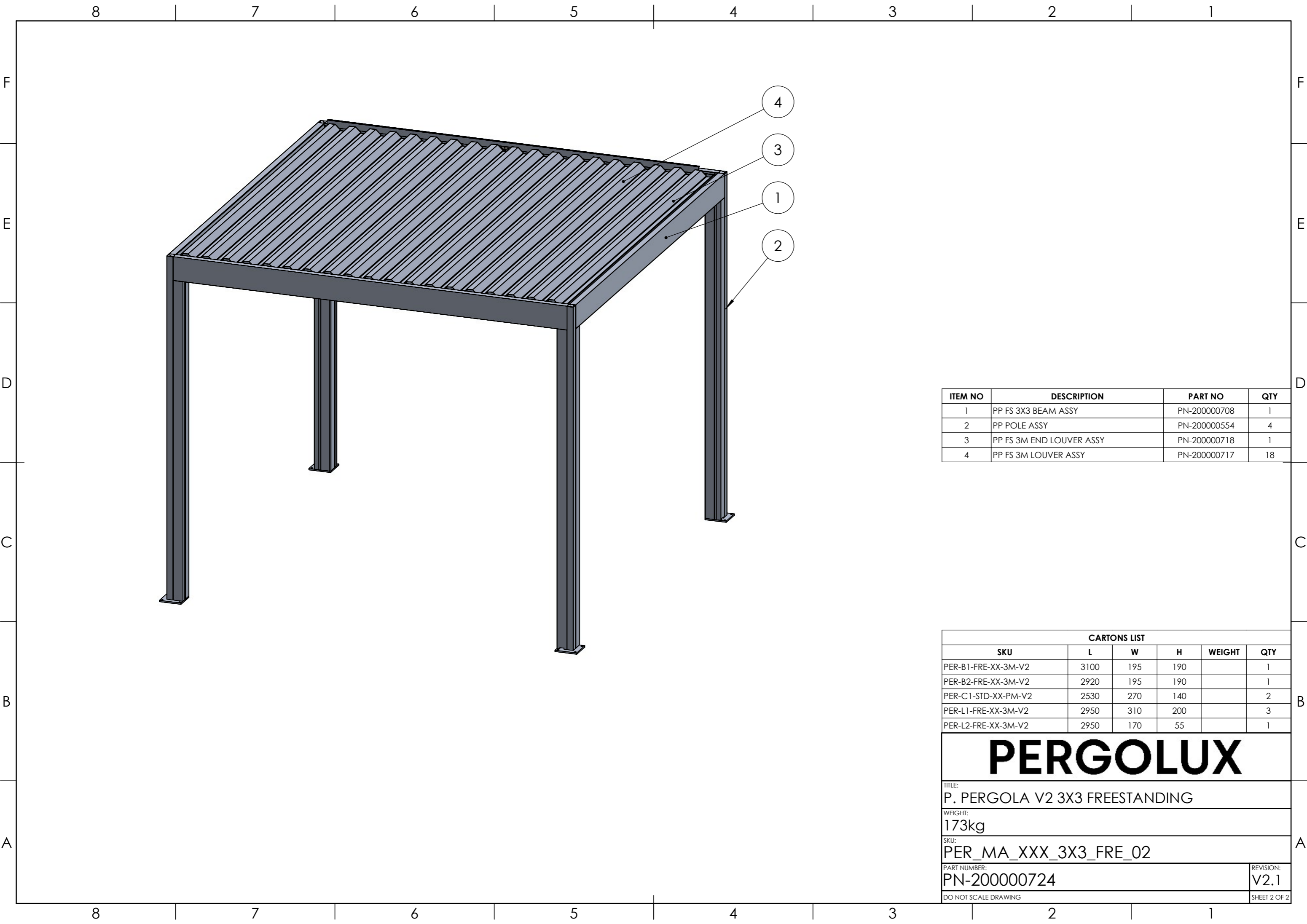

ITEM NO	DESCRIPTION	PART NO	QTY
1	PP FS 3X3 BEAM ASSY	PN-200000708	1
2	PP POLE ASSY	PN-200000554	4
3	PP FS 3M END LOUVER ASSY	PN-200000718	1
4	PP FS 3M LOUVER ASSY	PN-200000717	18

CARTONS LIST					
SKU	L	W	H	WEIGHT	QTY
PER-B1-FRE-XX-3M-V2	3100	195	190		1
PER-B2-FRE-XX-3M-V2	2920	195	190		1
PER-C1-STD-XX-PM-V2	2530	270	140		2
PER-L1-FRE-XX-3M-V2	2950	310	200		3
PER-L2-FRE-XX-3M-V2	2950	170	55		1

PERGOLUX

TITLE:
P. PERGOLA V2 3X3 FREESTANDING

WEIGHT:
173kg

SKU:
PER_MA_XXX_3X3_FRE_02

PART NUMBER: PN-200000724	REVISION: V2.1
------------------------------	-------------------

DO NOT SCALE DRAWING SHEET 2 OF 2

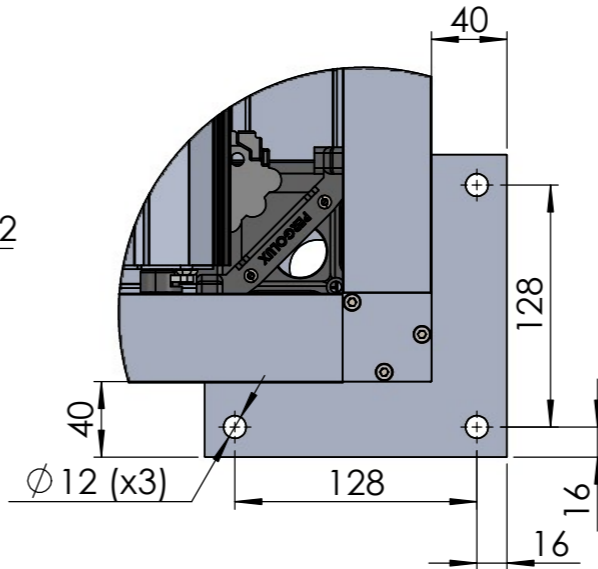
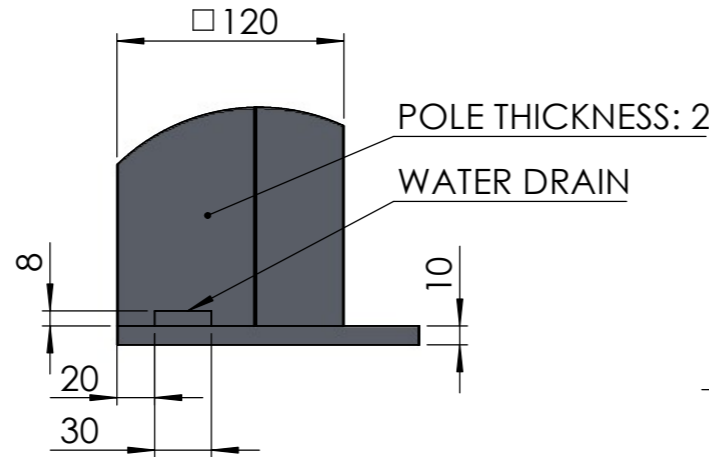
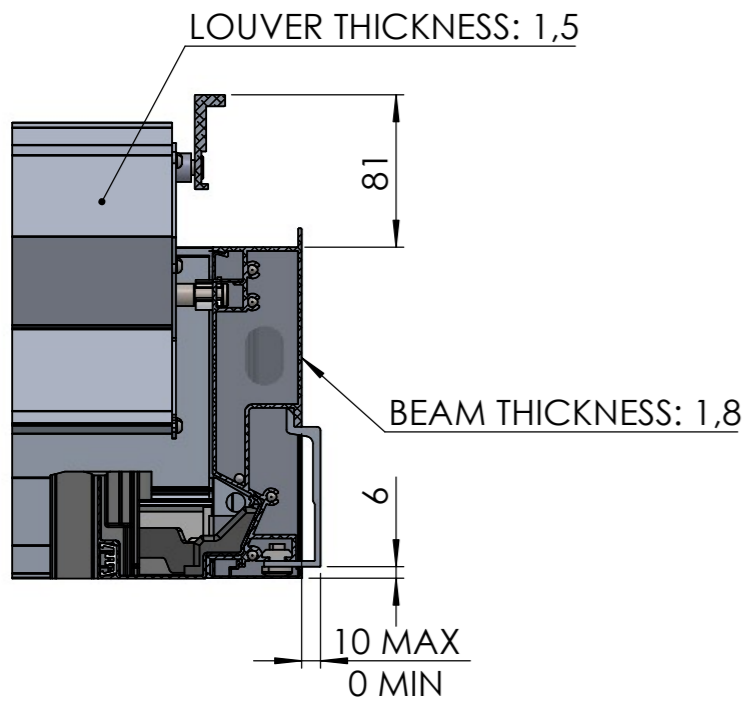
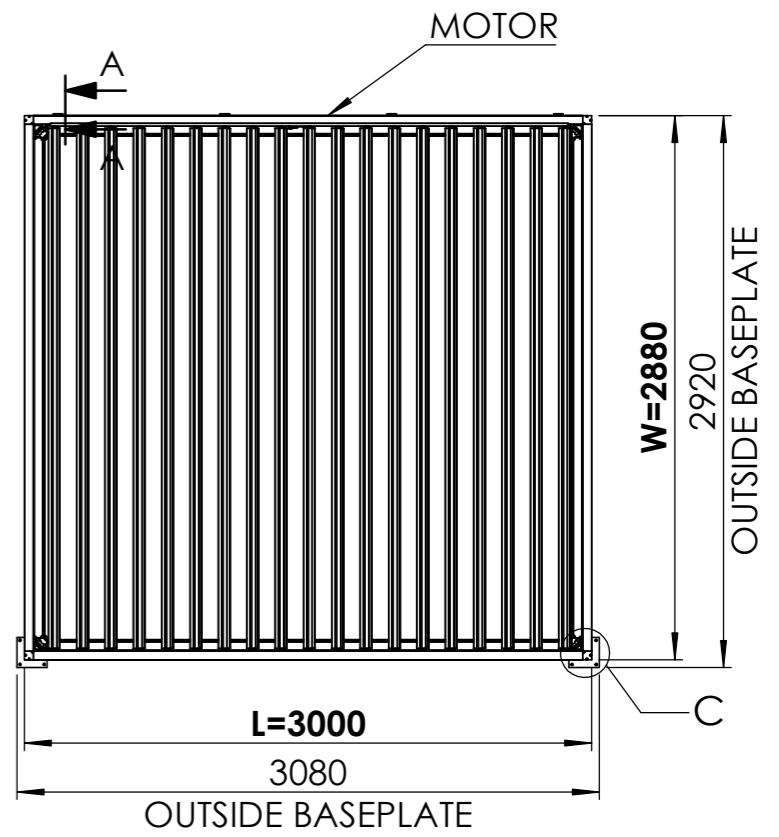
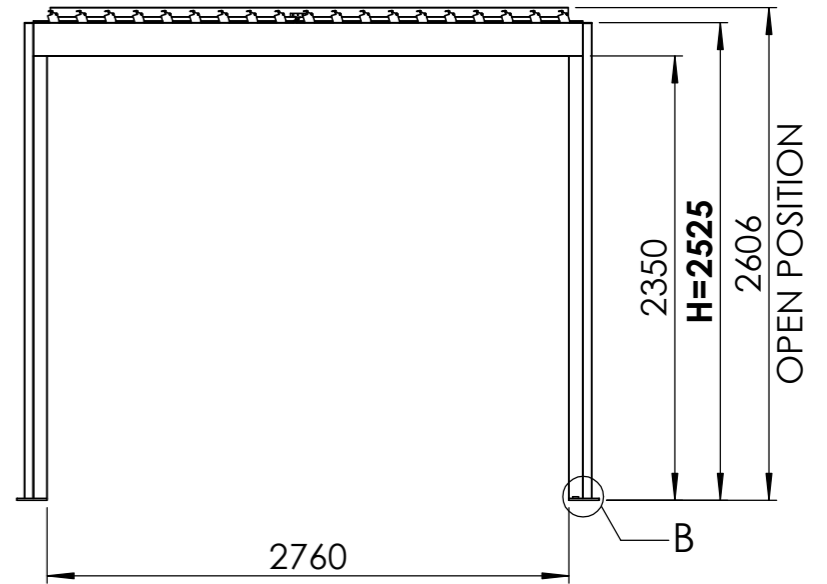

PERGOLUX

TITLE: P. PERGOLA V2 3X3 WALLFIXED	
WEIGHT: 148kg	
SKU: PER_MA_XXX_3X3_WAL_02	
PART NUMBER: PN-200000674	REVISION: V2.1
DO NOT SCALE DRAWING	ALL DIMENSIONS ARE IN MILLIMETERS
	SHEET 1 OF 2

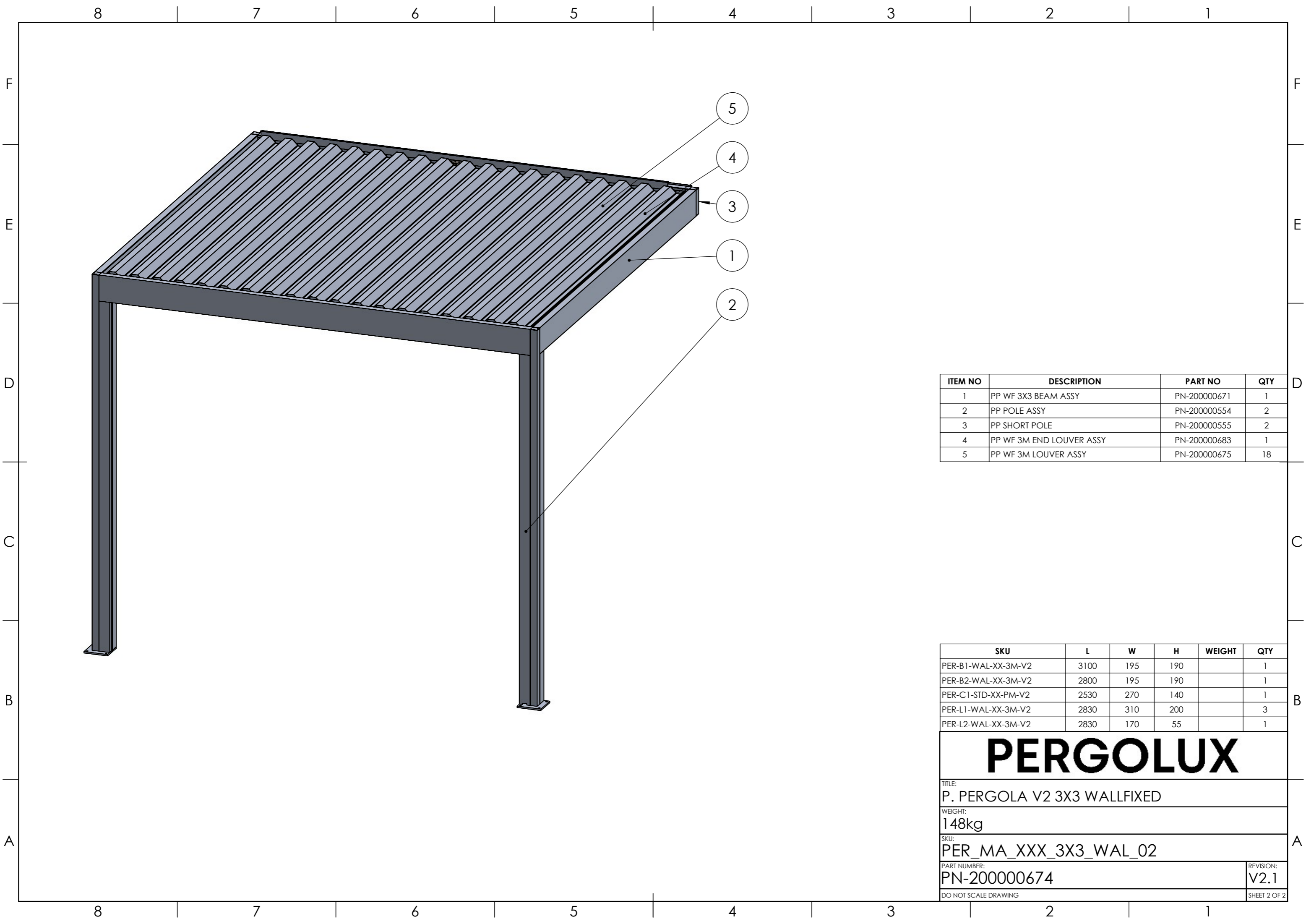

ITEM NO	DESCRIPTION	PART NO	QTY
1	PP WF 3X3 BEAM ASSY	PN-200000671	1
2	PP POLE ASSY	PN-200000554	2
3	PP SHORT POLE	PN-200000555	2
4	PP WF 3M END LOUVER ASSY	PN-200000683	1
5	PP WF 3M LOUVER ASSY	PN-200000675	18

SKU	L	W	H	WEIGHT	QTY
PER-B1-WAL-XX-3M-V2	3100	195	190		1
PER-B2-WAL-XX-3M-V2	2800	195	190		1
PER-C1-STD-XX-PM-V2	2530	270	140		1
PER-L1-WAL-XX-3M-V2	2830	310	200		3
PER-L2-WAL-XX-3M-V2	2830	170	55		1

PERGOLUX

TITLE:
P. PERGOLA V2 3X3 WALLFIXED

WEIGHT:
148kg

SKU:
PER_MA_XXX_3X3_WAL_02

PART NUMBER: PN-200000674	REVISION: V2.1
------------------------------	-------------------

DO NOT SCALE DRAWING

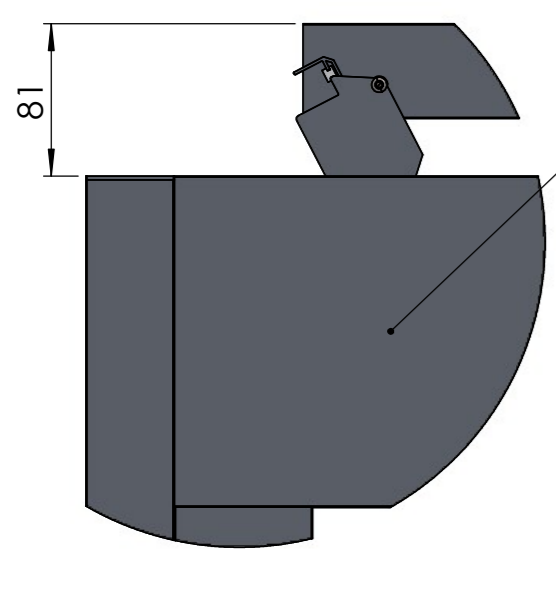
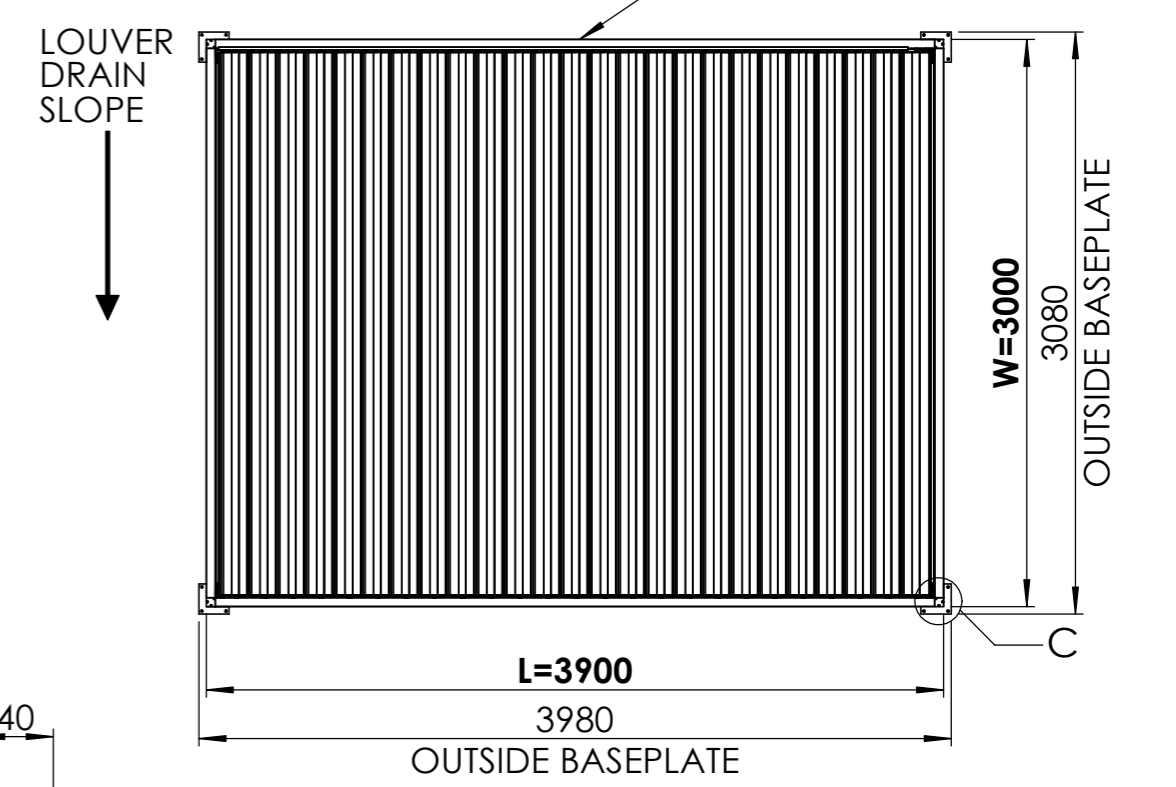
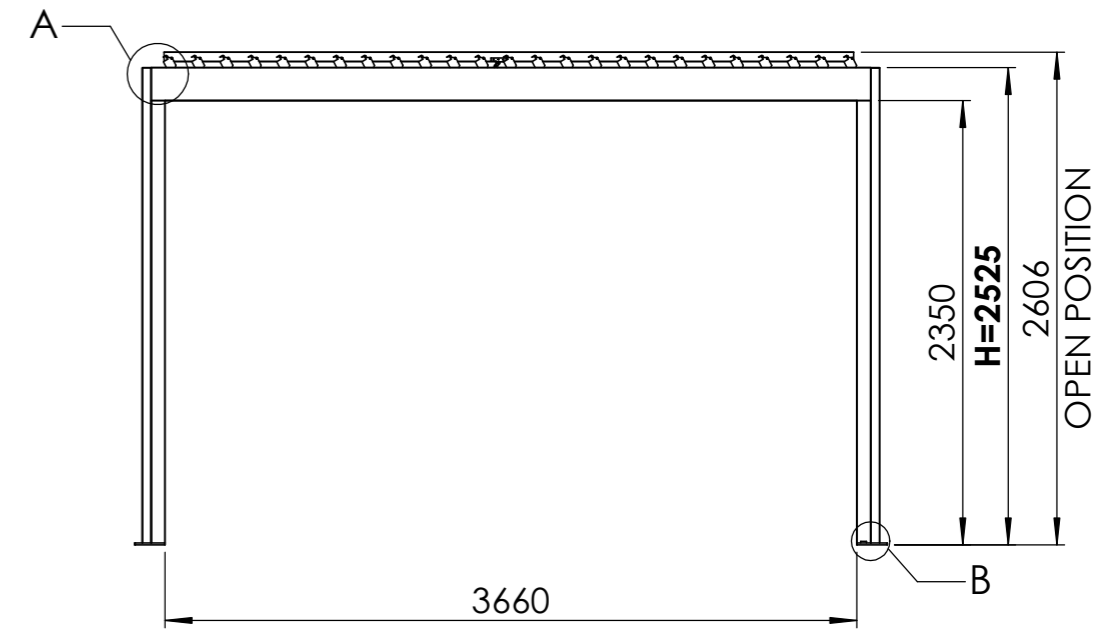

BEAM THICKNESS: 1,8

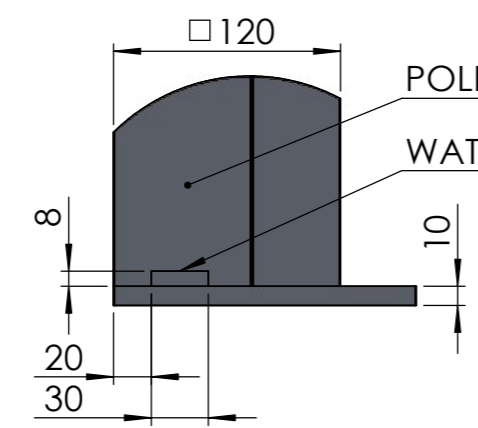

POLE THICKNESS: 2

WATER DRAIN

LOUVER THICKNESS: 1,5

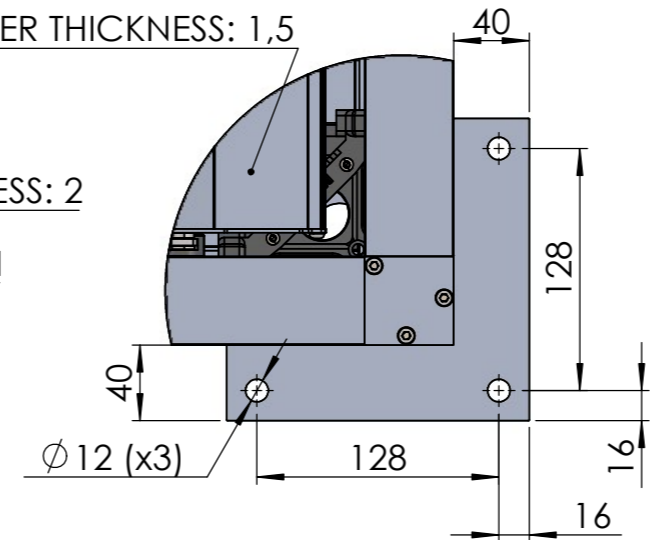

DETAIL A
OPEN POSITION

DETAIL B

DETAIL C

PERGOLUX	
TITLE: P. PERGOLA V2 3X4 FREESTANDING	
WEIGHT: 205kg	
SKU: PER_MA_XXX_3X4_FRE_02	
PART NUMBER: PN-200000725	REVISION V2.1
DO NOT SCALE DRAWING	ALL DIMENSIONS ARE IN MILLIMETERS
	SHEET 1 OF 2

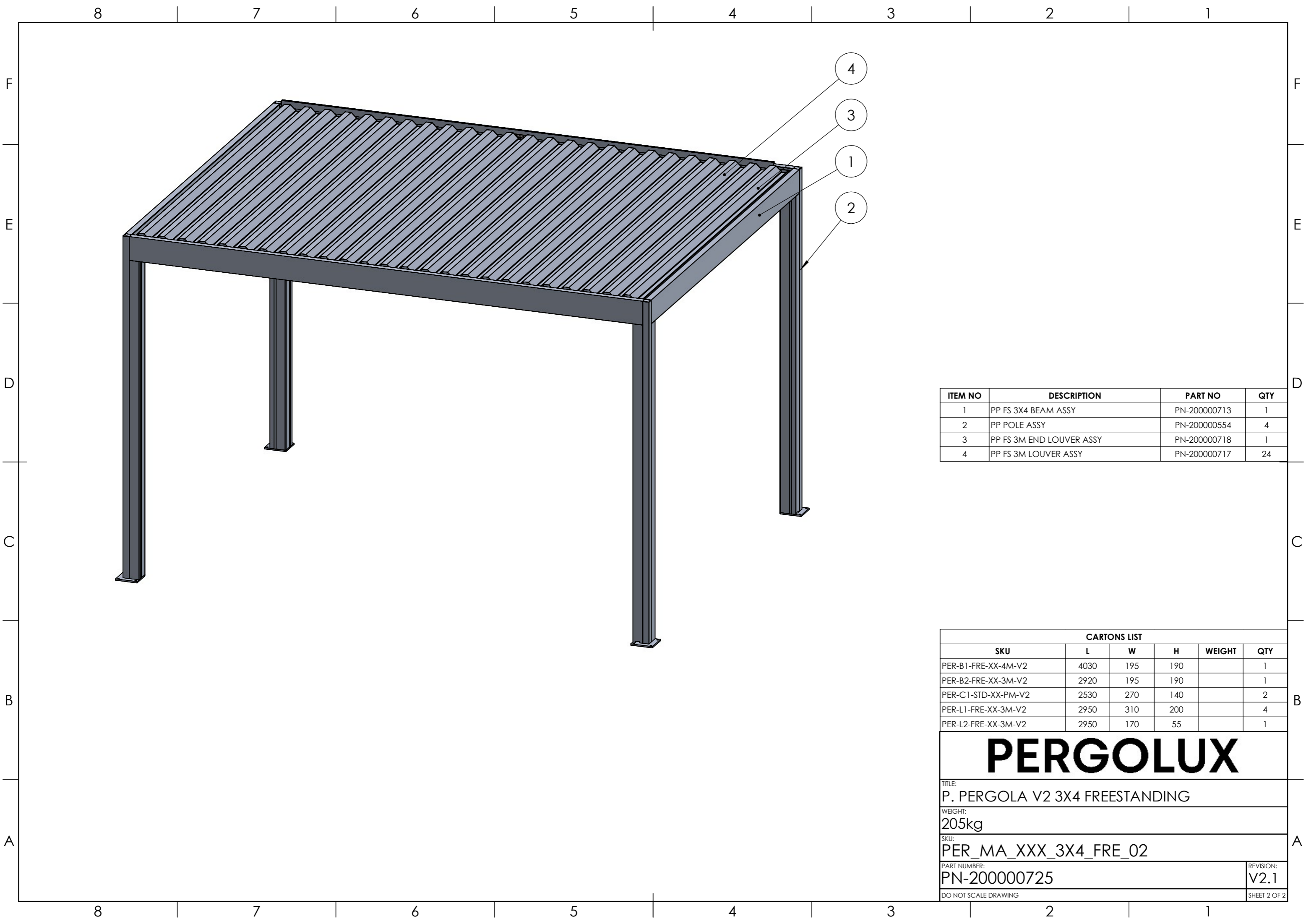

ITEM NO	DESCRIPTION	PART NO	QTY
1	PP FS 3X4 BEAM ASSY	PN-200000713	1
2	PP POLE ASSY	PN-200000554	4
3	PP FS 3M END LOUVER ASSY	PN-200000718	1
4	PP FS 3M LOUVER ASSY	PN-200000717	24

CARTONS LIST					
SKU	L	W	H	WEIGHT	QTY
PER-B1-FRE-XX-4M-V2	4030	195	190		1
PER-B2-FRE-XX-3M-V2	2920	195	190		1
PER-C1-STD-XX-PM-V2	2530	270	140		2
PER-L1-FRE-XX-3M-V2	2950	310	200		4
PER-L2-FRE-XX-3M-V2	2950	170	55		1

PERGOLUX

TITLE:
P. PERGOLA V2 3X4 FREESTANDING

WEIGHT:
205kg

SKU:
PER_MA_XXX_3X4_FRE_02

PART NUMBER: PN-200000725	REVISION: V2.1
------------------------------	-------------------

DO NOT SCALE DRAWING SHEET 2 OF 2

8 7 6 5 4 3 2 1

F
E
D
C
B
A

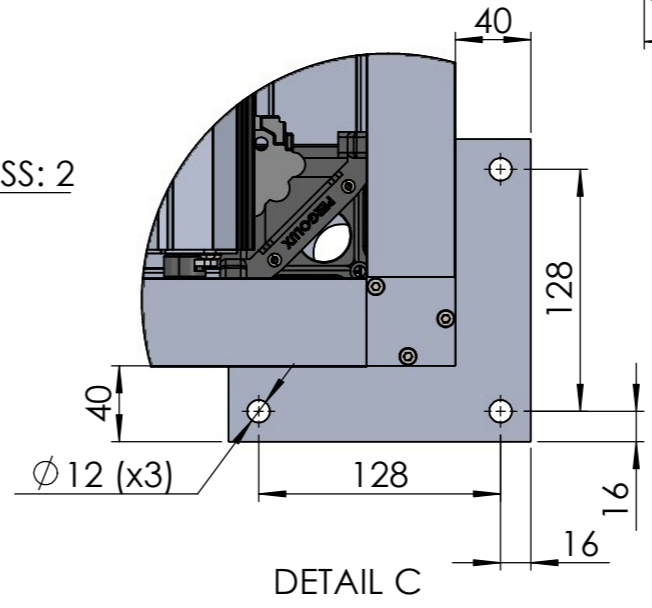
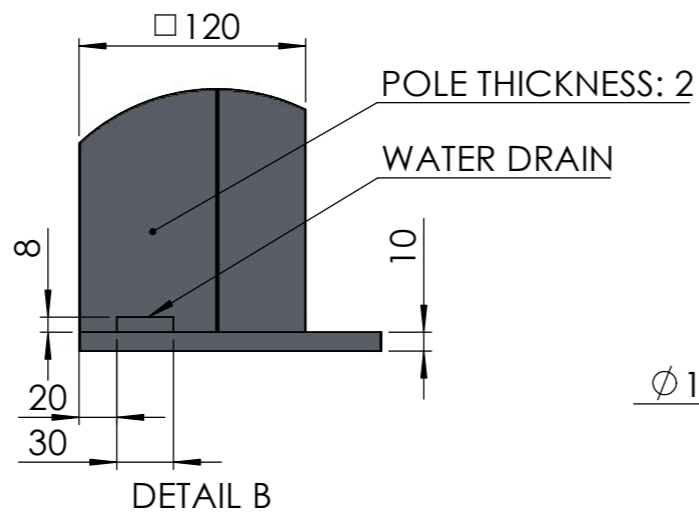
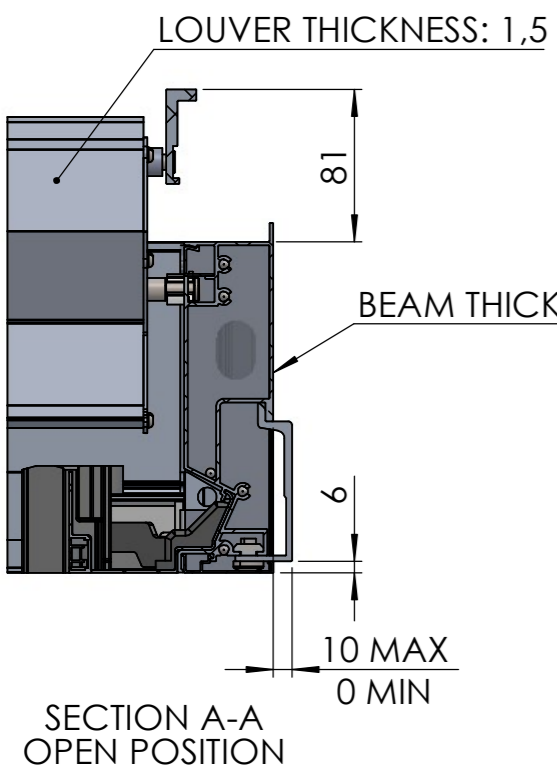
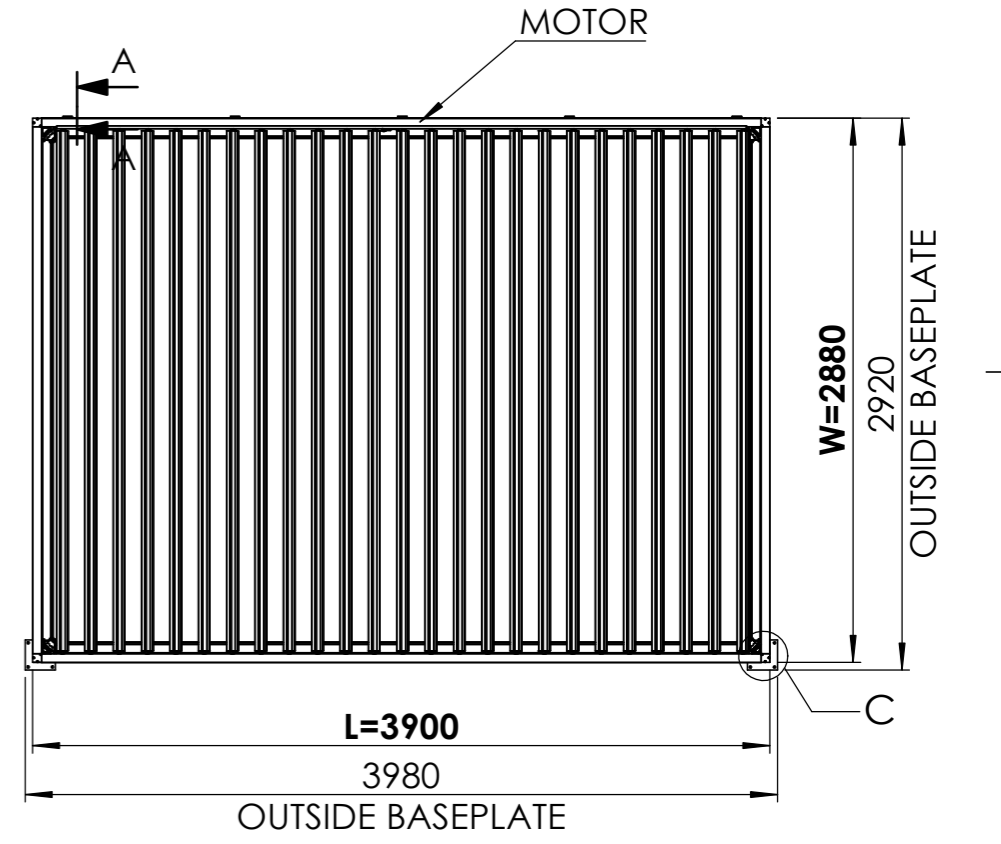
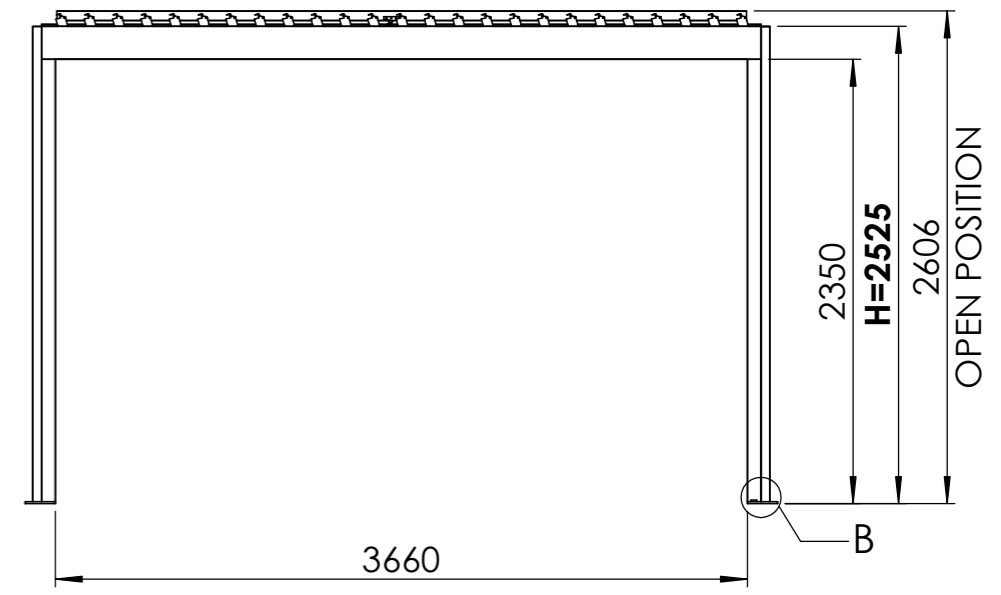

PERGOLUX	
TITLE: P. PERGOLA V2 3X4 WALLFIX	
WEIGHT: 180kg	
SKU: PER_MA_XXX_3X4_WAL_02	
PART NUMBER: PN-200000702	REVISION V2.1
DO NOT SCALE DRAWING	ALL DIMENSIONS ARE IN MILLIMETERS
	SHEET 1 OF 2

8 7 6 5 4 3 2 1

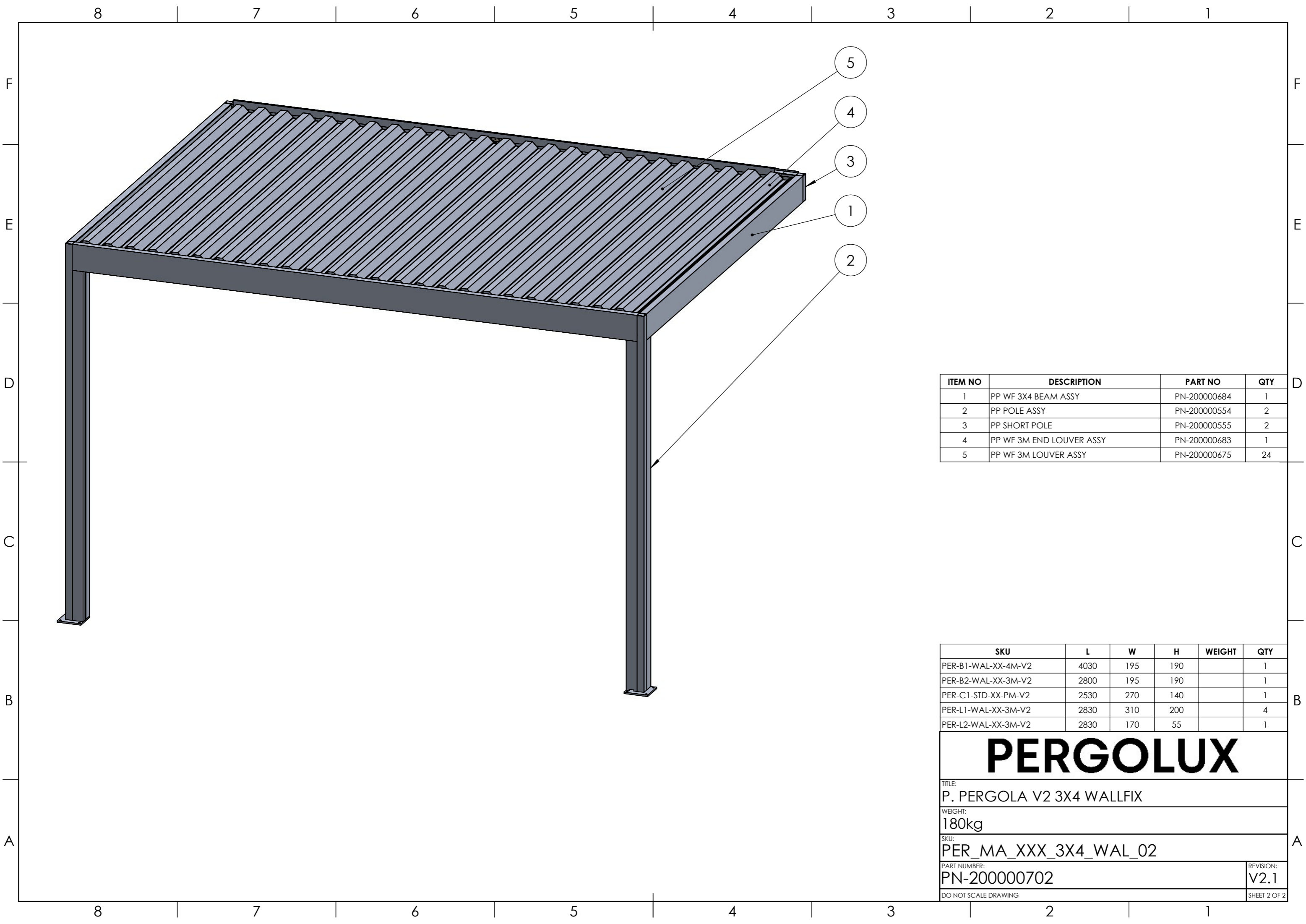

ITEM NO	DESCRIPTION	PART NO	QTY
1	PP WF 3X4 BEAM ASSY	PN-200000684	1
2	PP POLE ASSY	PN-200000554	2
3	PP SHORT POLE	PN-200000555	2
4	PP WF 3M END LOUVER ASSY	PN-200000683	1
5	PP WF 3M LOUVER ASSY	PN-200000675	24

SKU	L	W	H	WEIGHT	QTY
PER-B1-WAL-XX-4M-V2	4030	195	190		1
PER-B2-WAL-XX-3M-V2	2800	195	190		1
PER-C1-STD-XX-PM-V2	2530	270	140		1
PER-L1-WAL-XX-3M-V2	2830	310	200		4
PER-L2-WAL-XX-3M-V2	2830	170	55		1

PERGOLUX

TITLE:
P. PERGOLA V2 3X4 WALLFIX

WEIGHT:
180kg

SKU:
PER_MA_XXX_3X4_WAL_02

PART NUMBER: PN-200000702	REVISION: V2.1
------------------------------	-------------------

DO NOT SCALE DRAWING SHEET 2 OF 2

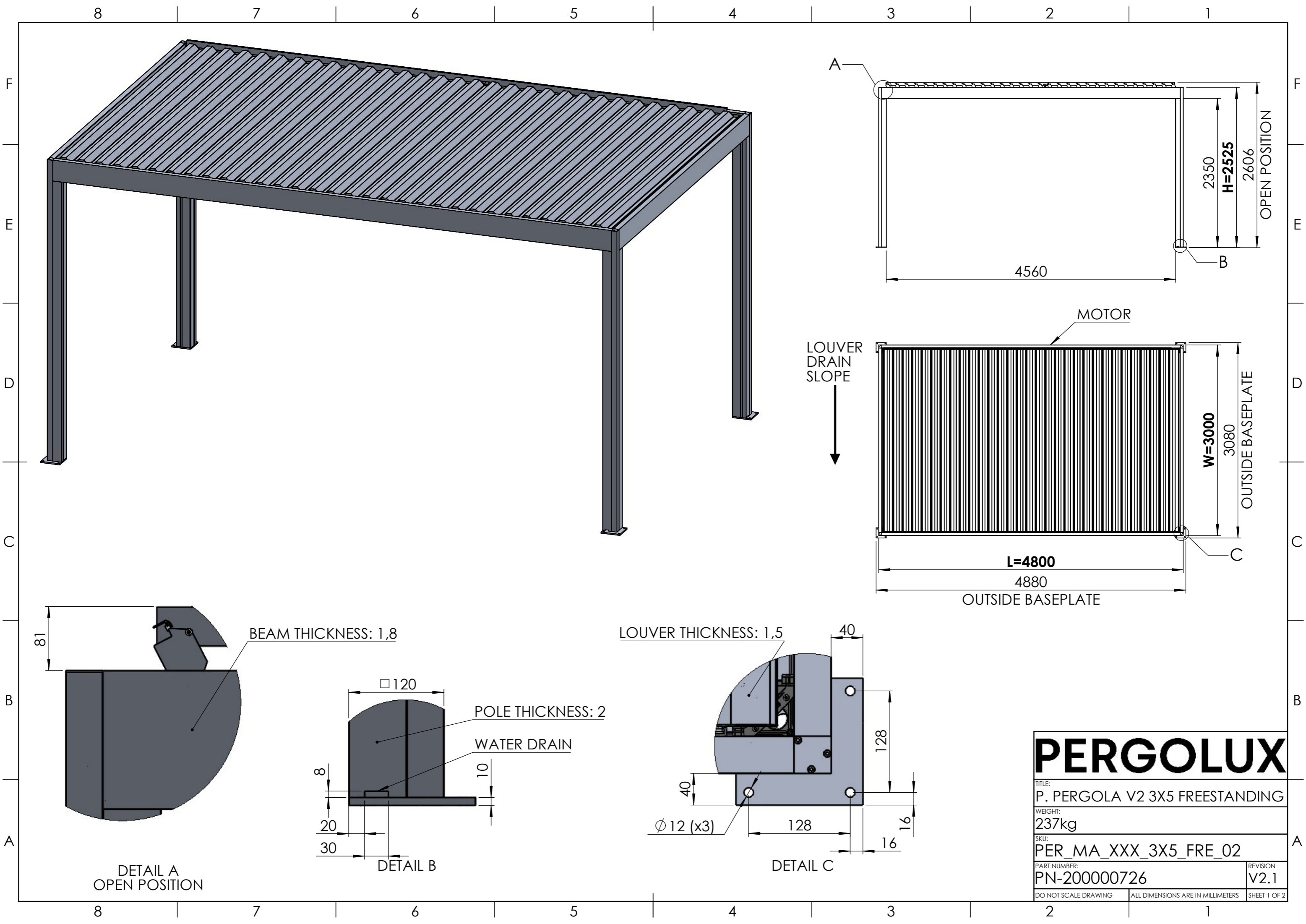

PERGOLUX	
TITLE: P. PERGOLA V2 3X5 FREESTANDING	
WEIGHT: 237kg	
SKU: PER_MA_XXX_3X5_FRE_02	
PART NUMBER: PN-200000726	REVISION V2.1
DO NOT SCALE DRAWING	ALL DIMENSIONS ARE IN MILLIMETERS
	SHEET 1 OF 2

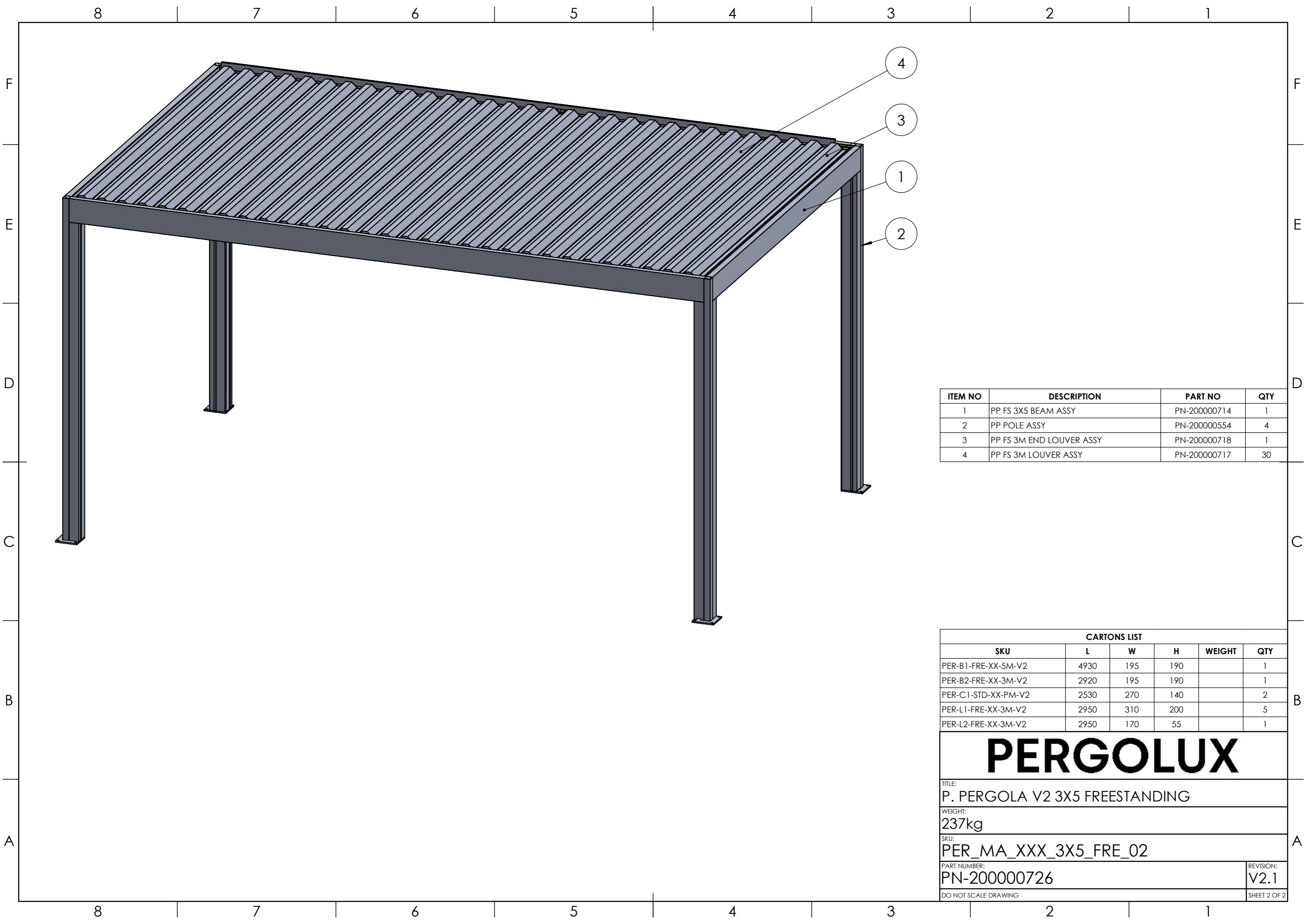

ITEM NO	DESCRIPTION	PART NO	QTY
1	PP FS 3X5 BEAM ASSY	PN-200000714	1
2	PP POLE ASSY	PN-200000554	4
3	PP FS 3M END LOUVER ASSY	PN-200000718	1
4	PP FS 3M LOUVER ASSY	PN-200000717	30

CARTONS LIST					
SKU	L	W	H	WEIGHT	QTY
PER-B1-FRE-XX-5M-V2	4930	195	190		1
PER-B2-FRE-XX-3M-V2	2920	195	190		1
PER-C1-STD-XX-PM-V2	2530	270	140		2
PER-L1-FRE-XX-3M-V2	2950	310	200		5
PER-L2-FRE-XX-3M-V2	2950	170	55		1

PERGOLUX

TITLE:
P. PERGOLA V2 3X5 FREESTANDING

WEIGHT:
237kg

SKU:
PER_MA_XXX_3X5_FRE_02

PART NUMBER: PN-200000726	REVISION: V2.1
-------------------------------------	--------------------------

DO NOT SCALE DRAWING SHEET 2 OF 2

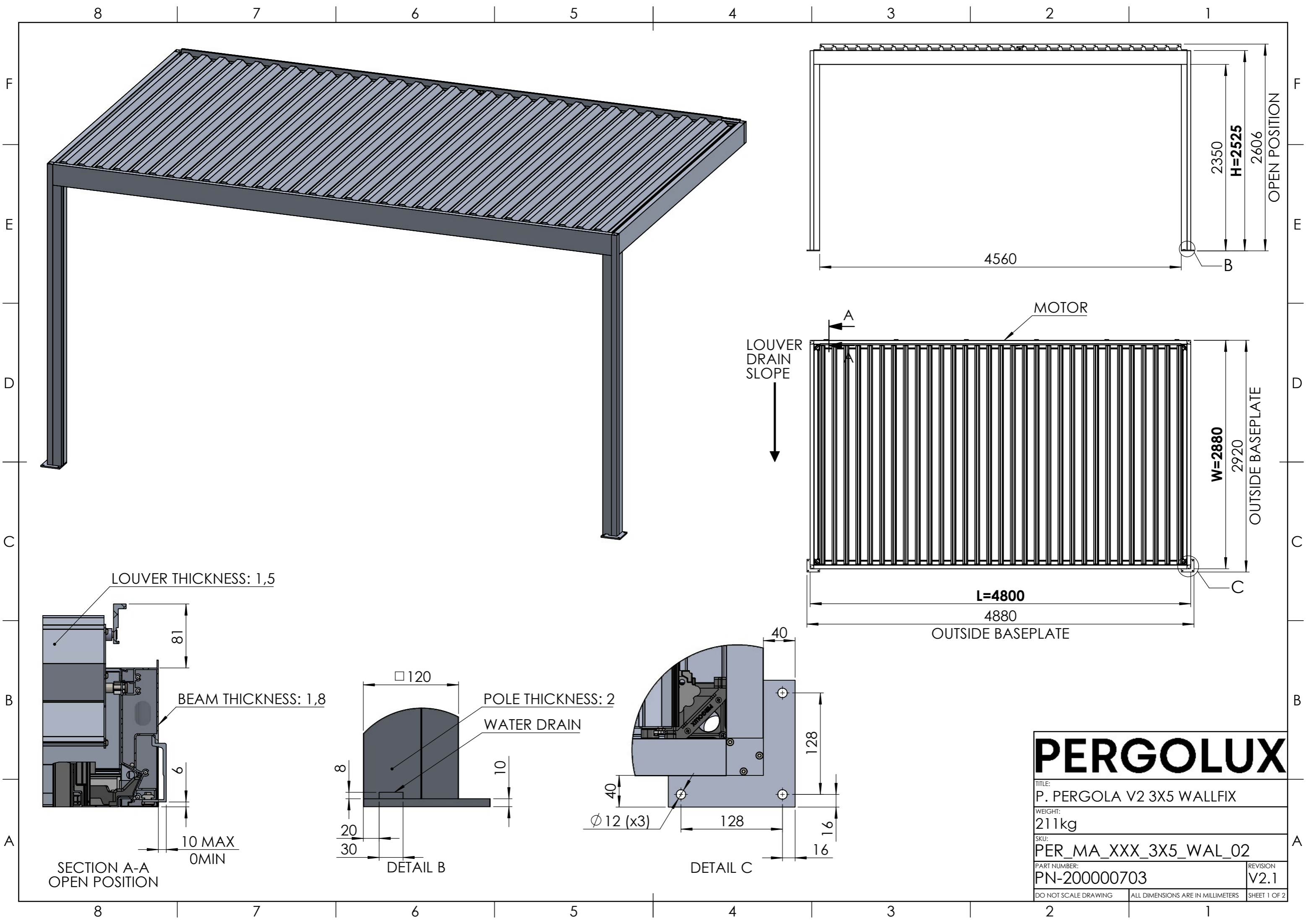

PERGOLUX

TITLE: P. PERGOLA V2 3X5 WALLFIX	
WEIGHT: 211kg	
SKU: PER_MA_XXX_3X5_WAL_02	
PART NUMBER: PN-200000703	REVISION V2.1
DO NOT SCALE DRAWING	ALL DIMENSIONS ARE IN MILLIMETERS
SHEET 1 OF 2	

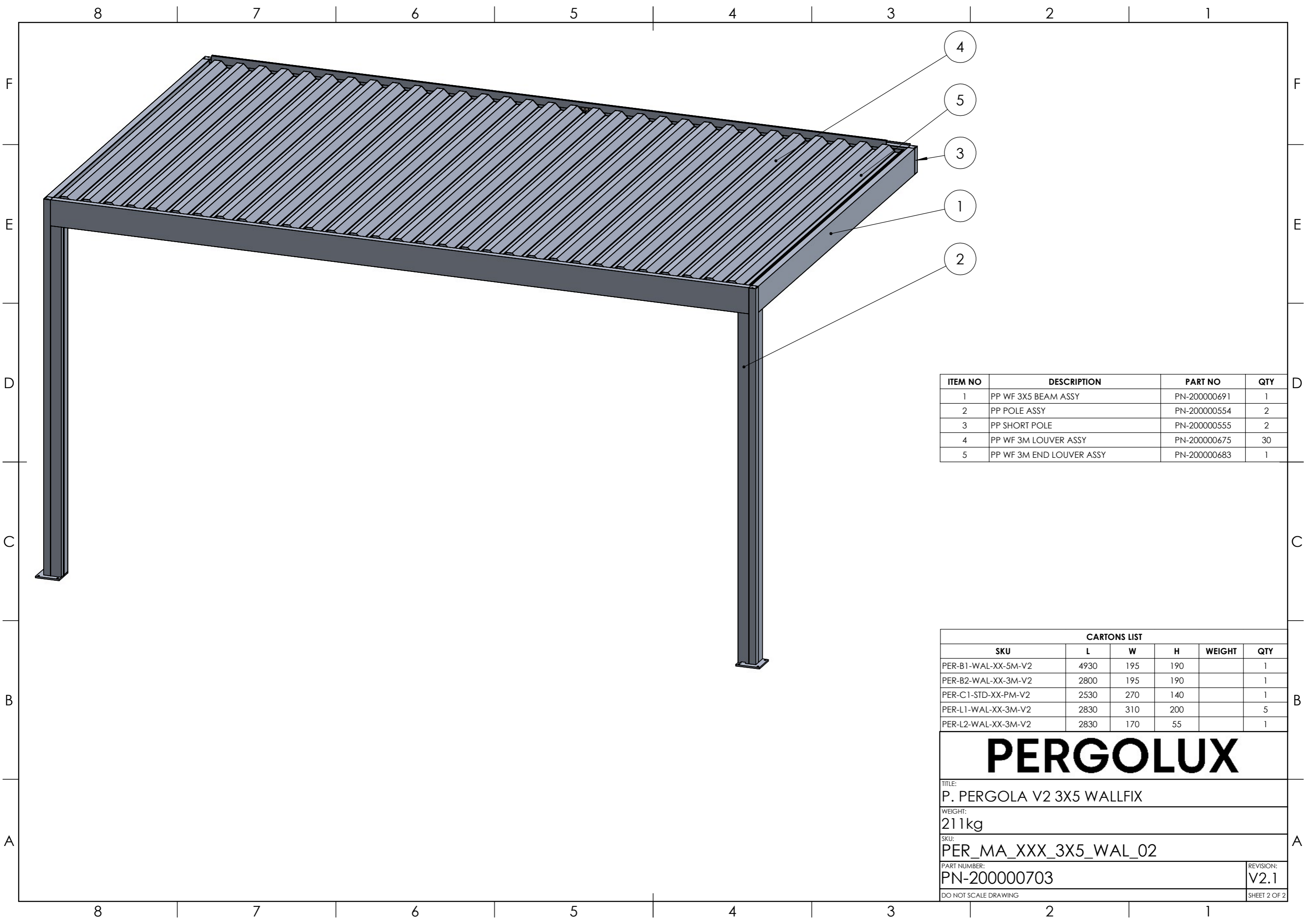

ITEM NO	DESCRIPTION	PART NO	QTY
1	PP WF 3X5 BEAM ASSY	PN-200000691	1
2	PP POLE ASSY	PN-200000554	2
3	PP SHORT POLE	PN-200000555	2
4	PP WF 3M LOUVER ASSY	PN-200000675	30
5	PP WF 3M END LOUVER ASSY	PN-200000683	1

CARTONS LIST					
SKU	L	W	H	WEIGHT	QTY
PER-B1-WAL-XX-5M-V2	4930	195	190		1
PER-B2-WAL-XX-3M-V2	2800	195	190		1
PER-C1-STD-XX-PM-V2	2530	270	140		1
PER-L1-WAL-XX-3M-V2	2830	310	200		5
PER-L2-WAL-XX-3M-V2	2830	170	55		1

PERGOLUX

TITLE:
P. PERGOLA V2 3X5 WALLFIX

WEIGHT:
211kg

SKU:
PER_MA_XXX_3X5_WAL_02

PART NUMBER: PN-200000703	REVISION: V2.1
-------------------------------------	--------------------------

DO NOT SCALE DRAWING SHEET 2 OF 2

8 7 6 5 4 3 2 1

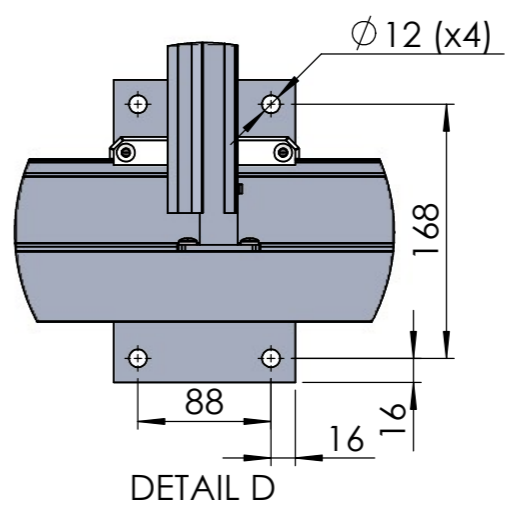
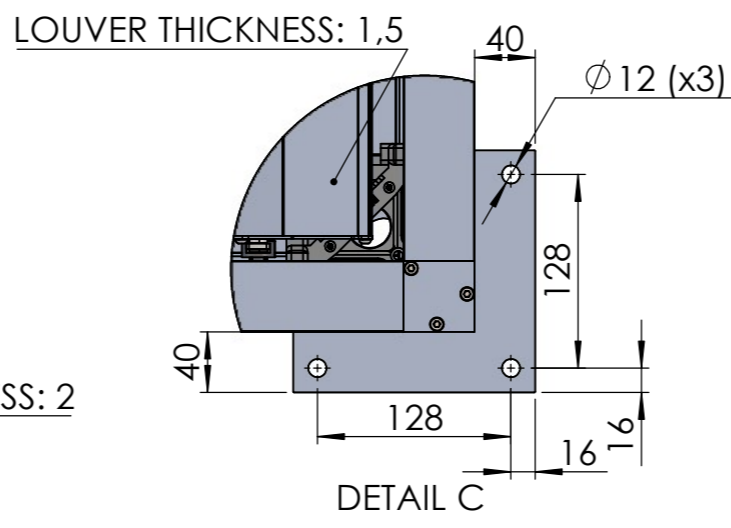
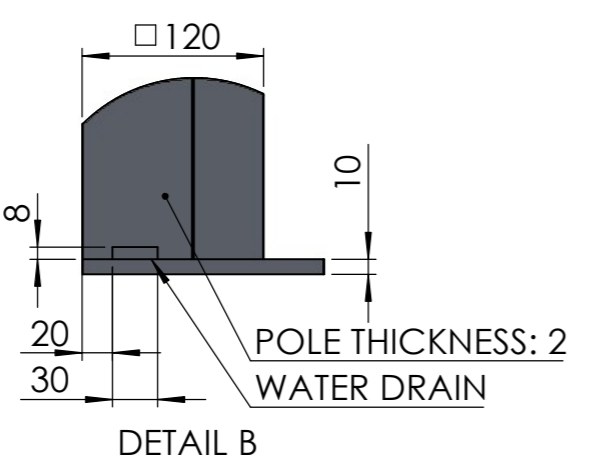
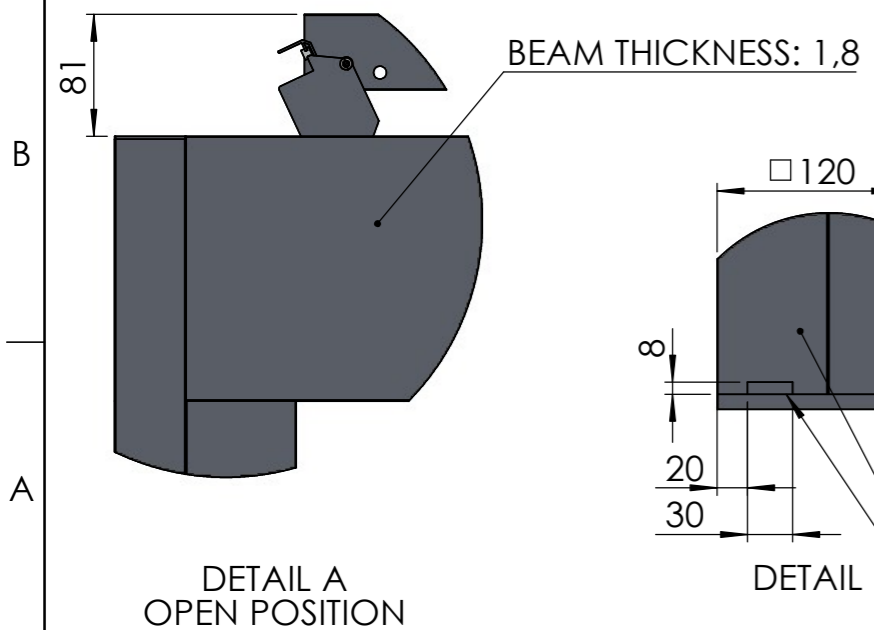
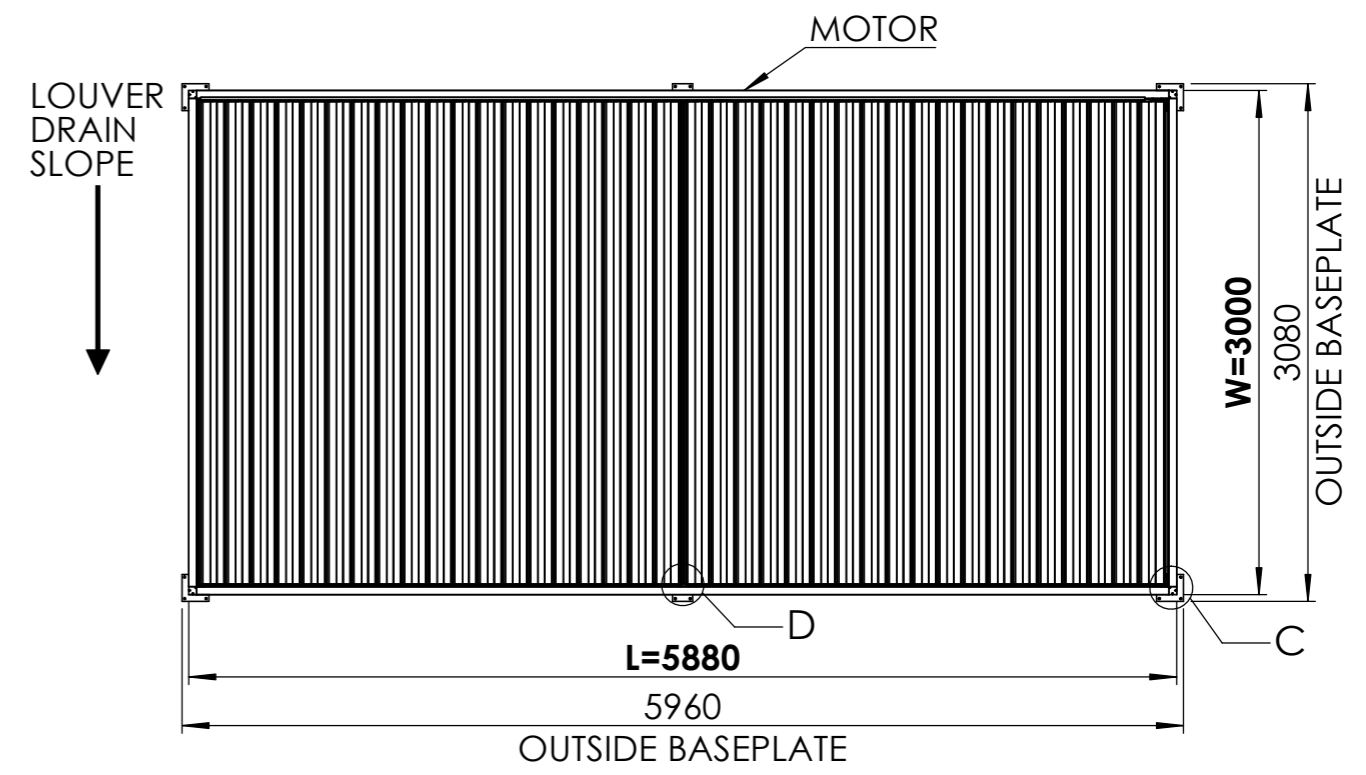
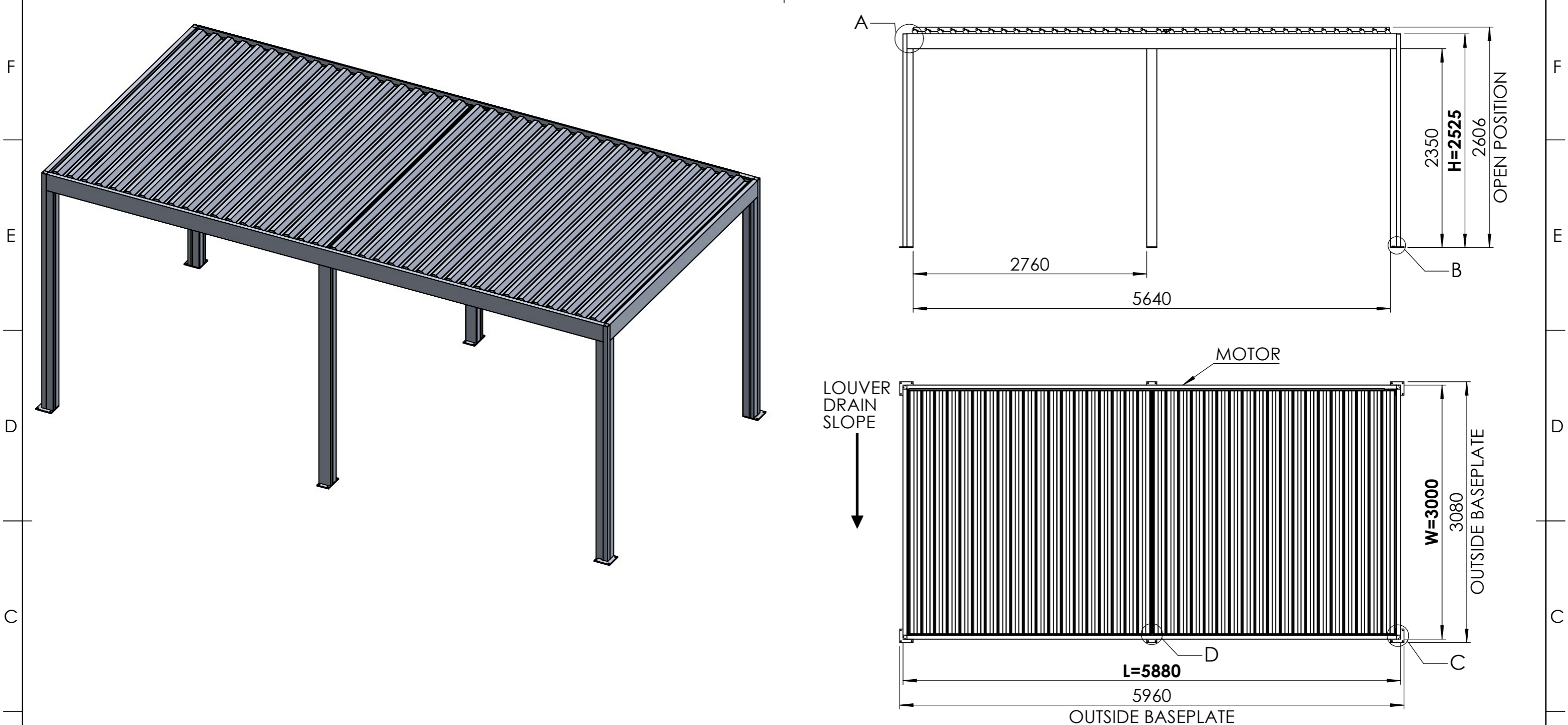

PERGOLUX		
TITLE: P. PERGOLA V2 3X6 FREESTANDING		
WEIGHT: 297kg		
SKU: PER_MA_XXX_3X6_FRE_02		
PART NUMBER: PN-200000747	REVISION 0.1	
DO NOT SCALE DRAWING	ALL DIMENSIONS ARE IN MILLIMETERS	SHEET 1 OF 2

8 7 6 5 4 3 2 1

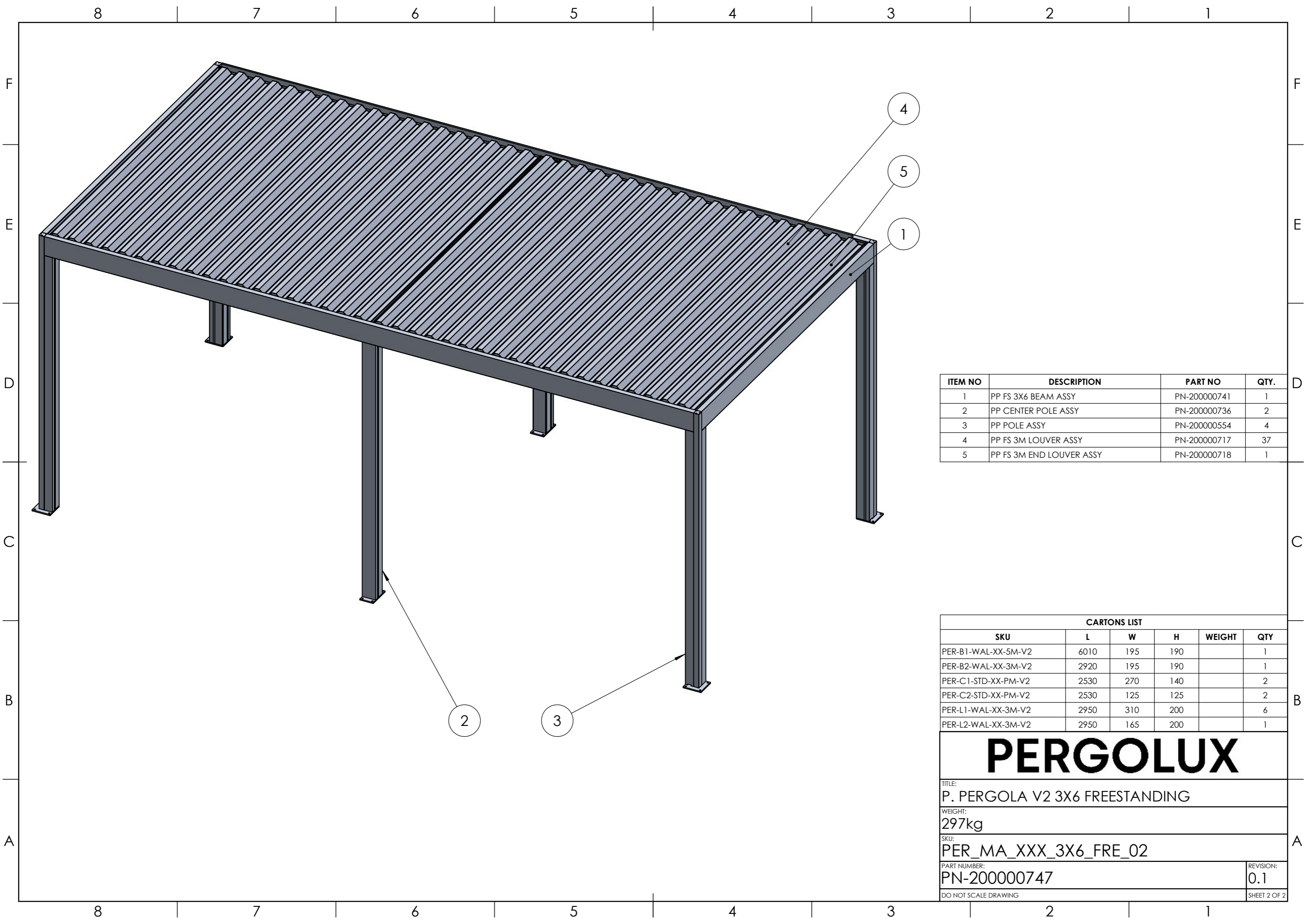

ITEM NO	DESCRIPTION	PART NO	QTY.
1	PP FS 3X6 BEAM ASSY	PN-200000741	1
2	PP CENTER POLE ASSY	PN-200000736	2
3	PP POLE ASSY	PN-200000554	4
4	PP FS 3M LOUVER ASSY	PN-200000717	37
5	PP FS 3M END LOUVER ASSY	PN-200000718	1

CARTONS LIST					
SKU	L	W	H	WEIGHT	QTY
PER-B1-WAL-XX-5M-V2	6010	195	190		1
PER-B2-WAL-XX-3M-V2	2920	195	190		1
PER-C1-STD-XX-PM-V2	2530	270	140		2
PER-C2-STD-XX-PM-V2	2530	125	125		2
PER-L1-WAL-XX-3M-V2	2950	310	200		6
PER-L2-WAL-XX-3M-V2	2950	165	200		1

PERGOLUX

TITLE:
P. PERGOLA V2 3X6 FREESTANDING

WEIGHT:
297kg

SKU:
PER_MA_XXX_3X6_FRE_02

PART NUMBER: PN-200000747	REVISION: 0.1
-------------------------------------	-------------------------

DO NOT SCALE DRAWING SHEET 2 OF 2

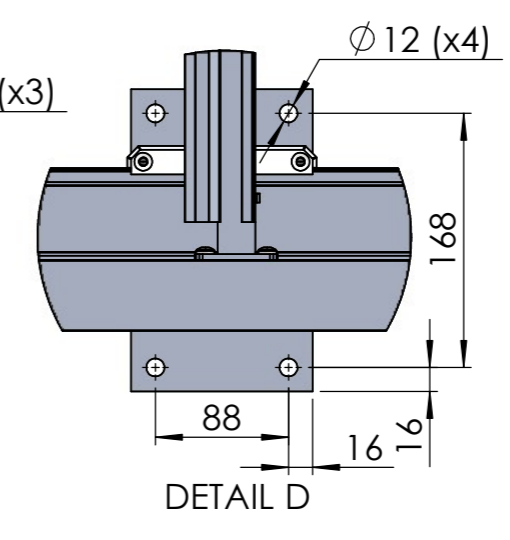
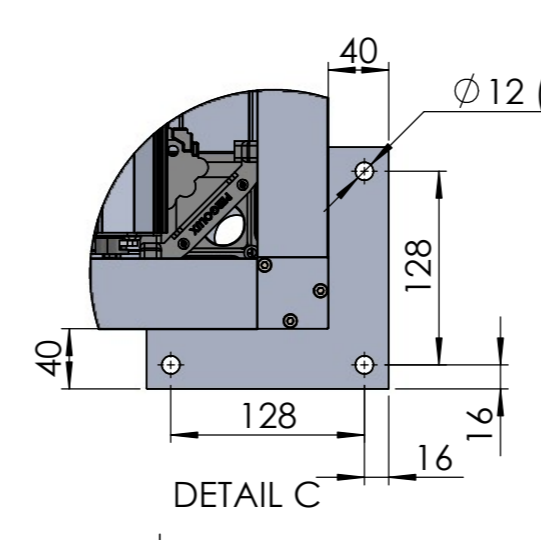
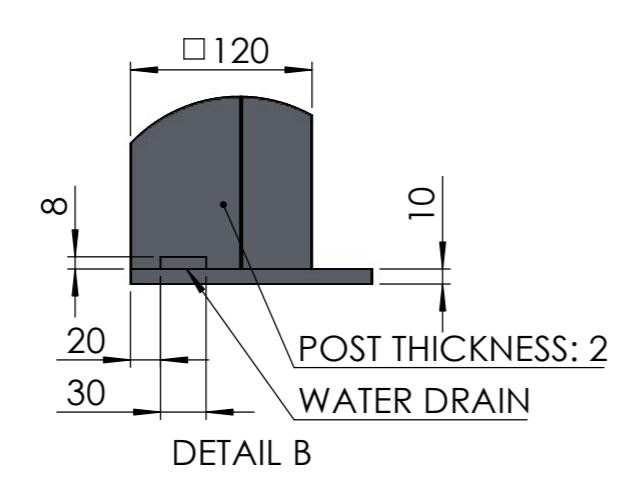
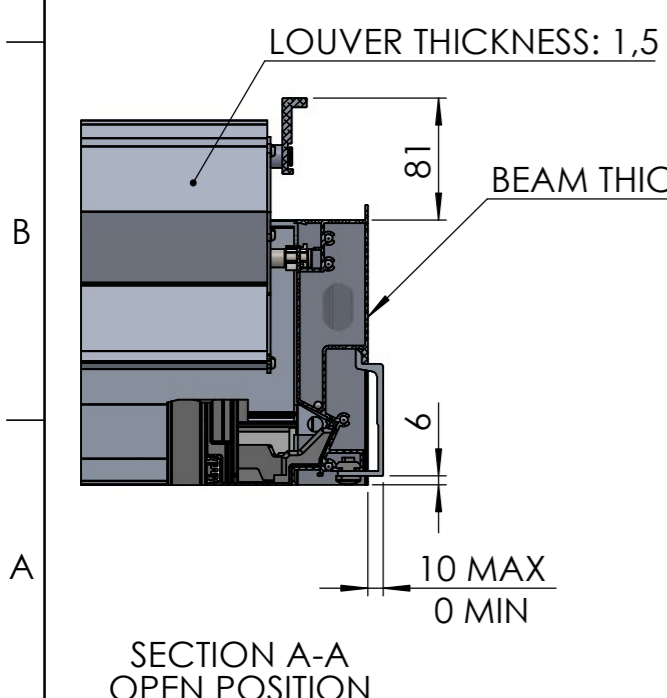
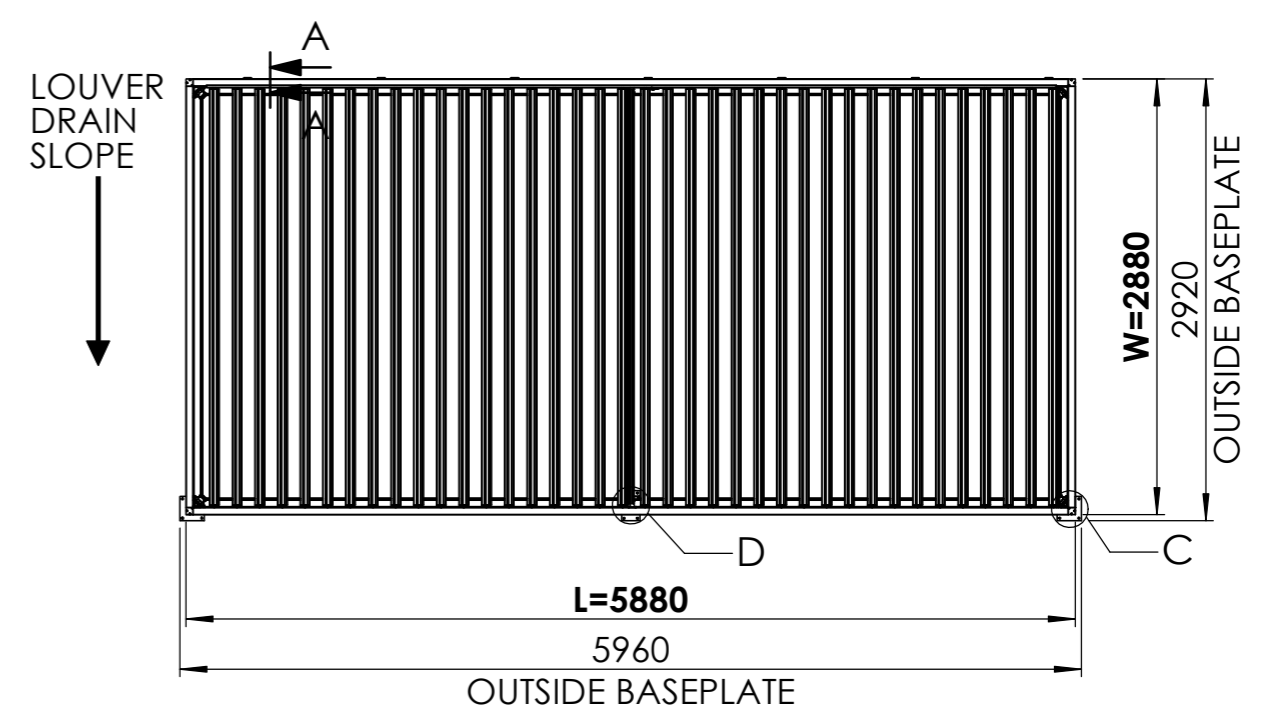
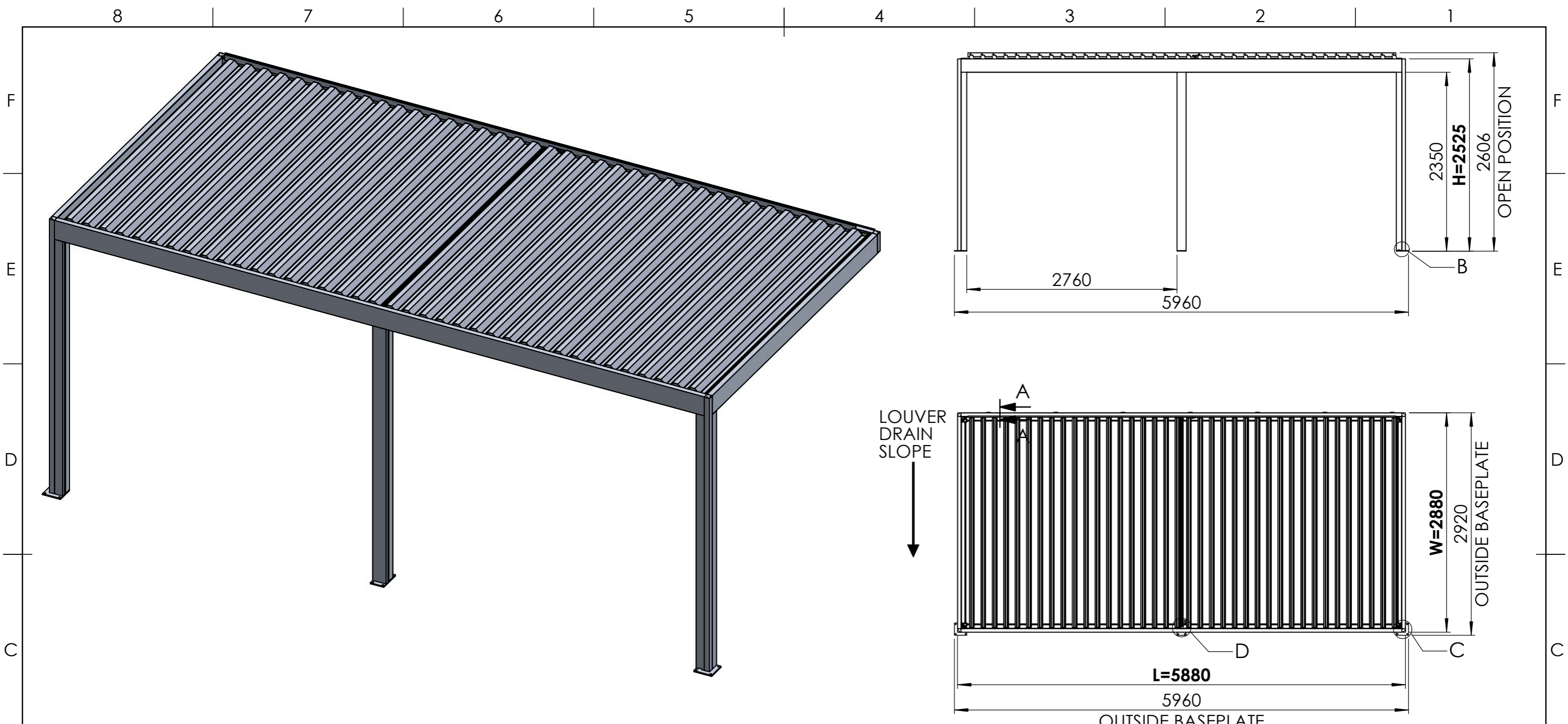

PERGOLUX		
TITLE: P. PERGOLA V2 3X6 WALLFIXED		
WEIGHT: 261kg		
SKU: PER_MA_XXX_3X6_WAL_02		
PART NUMBER: PN-200000756		REVISION 0.1
DO NOT SCALE DRAWING	ALL DIMENSIONS ARE IN MILLIMETERS	SHEET 1 OF 2

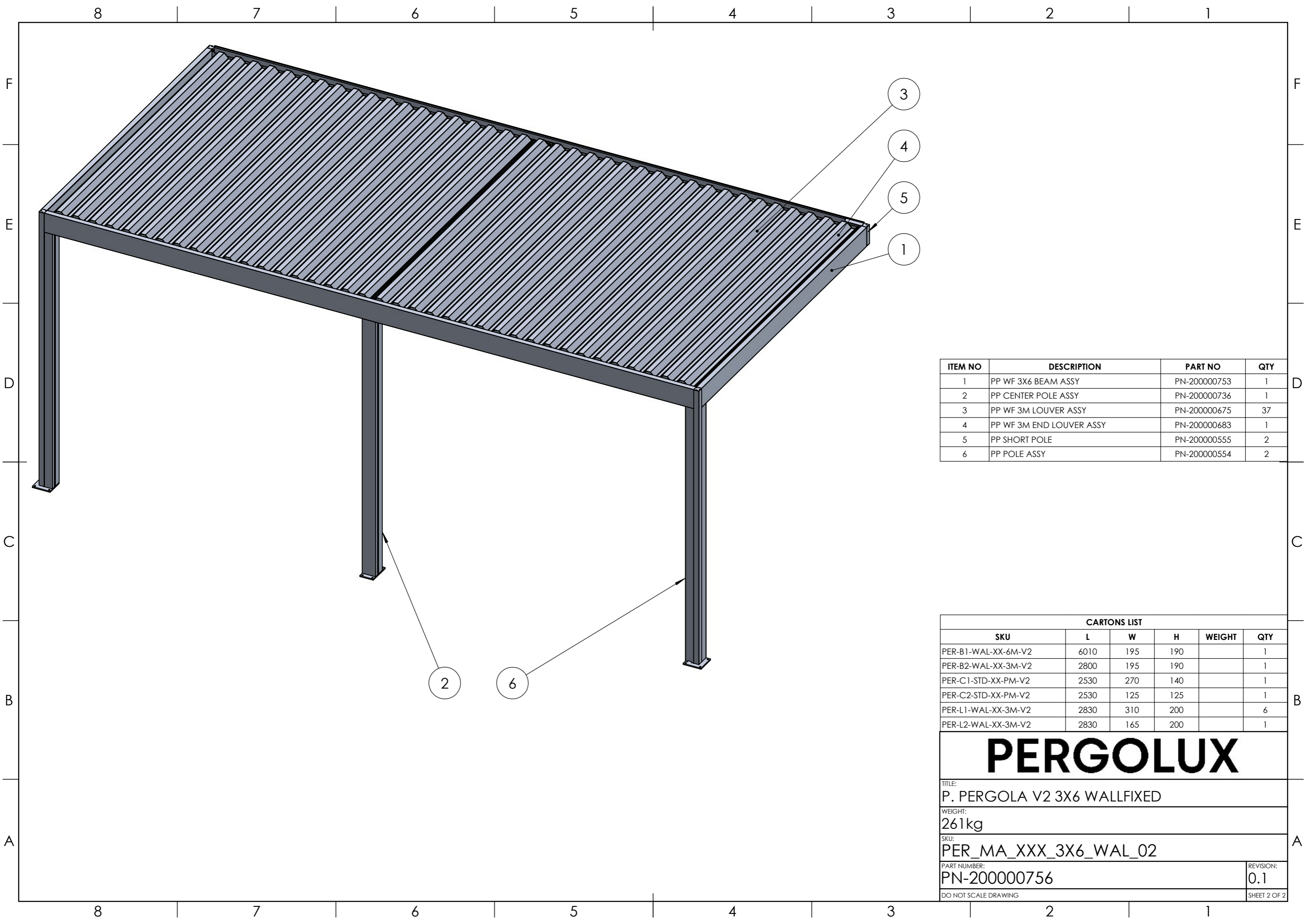

ITEM NO	DESCRIPTION	PART NO	QTY
1	PP WF 3X6 BEAM ASSY	PN-200000753	1
2	PP CENTER POLE ASSY	PN-200000736	1
3	PP WF 3M LOUVER ASSY	PN-200000675	37
4	PP WF 3M END LOUVER ASSY	PN-200000683	1
5	PP SHORT POLE	PN-200000555	2
6	PP POLE ASSY	PN-200000554	2

CARTONS LIST					
SKU	L	W	H	WEIGHT	QTY
PER-B1-WAL-XX-6M-V2	6010	195	190		1
PER-B2-WAL-XX-3M-V2	2800	195	190		1
PER-C1-STD-XX-PM-V2	2530	270	140		1
PER-C2-STD-XX-PM-V2	2530	125	125		1
PER-L1-WAL-XX-3M-V2	2830	310	200		6
PER-L2-WAL-XX-3M-V2	2830	165	200		1

PERGOLUX

TITLE:
P. PERGOLA V2 3X6 WALLFIXED

WEIGHT:
261kg

SKU:
PER_MA_XXX_3X6_WAL_02

PART NUMBER: PN-200000756	REVISION: 0.1
-------------------------------------	-------------------------

DO NOT SCALE DRAWING SHEET 2 OF 2

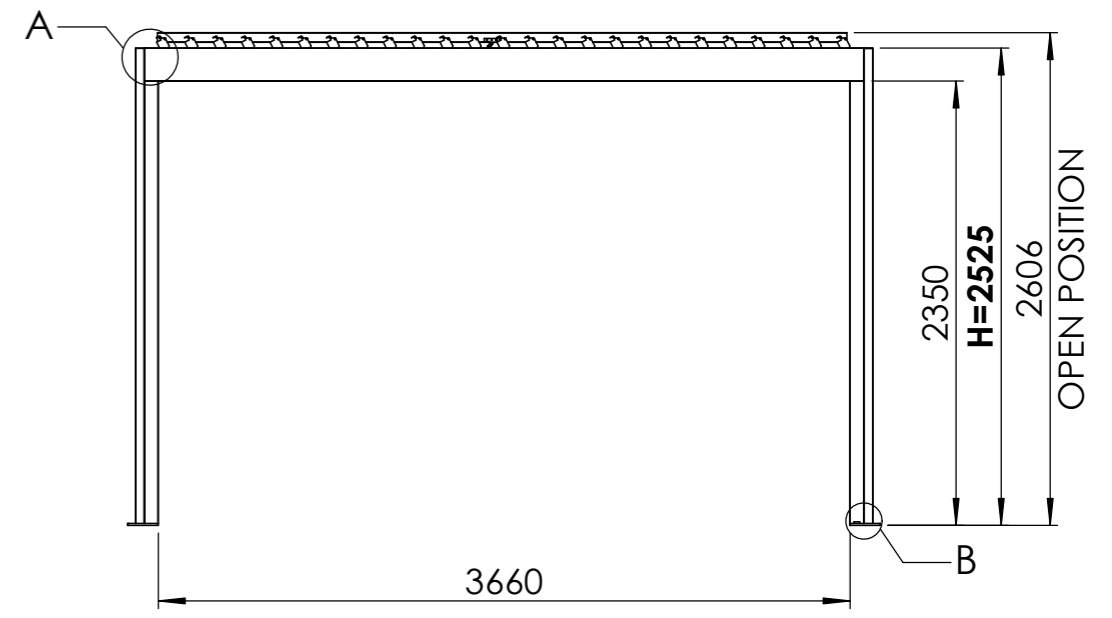

LOUVER
DRAIN
SLOPE

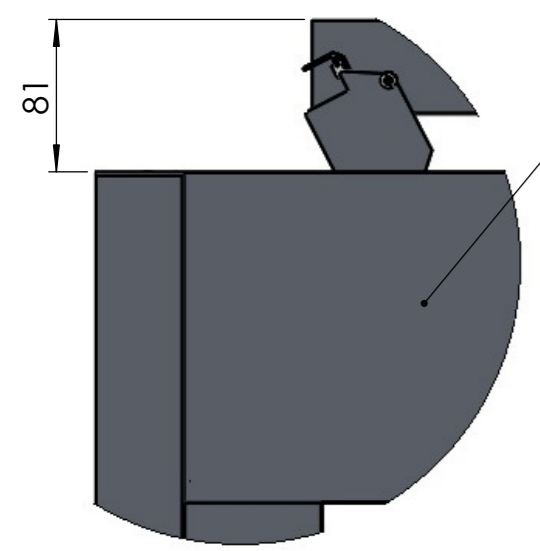
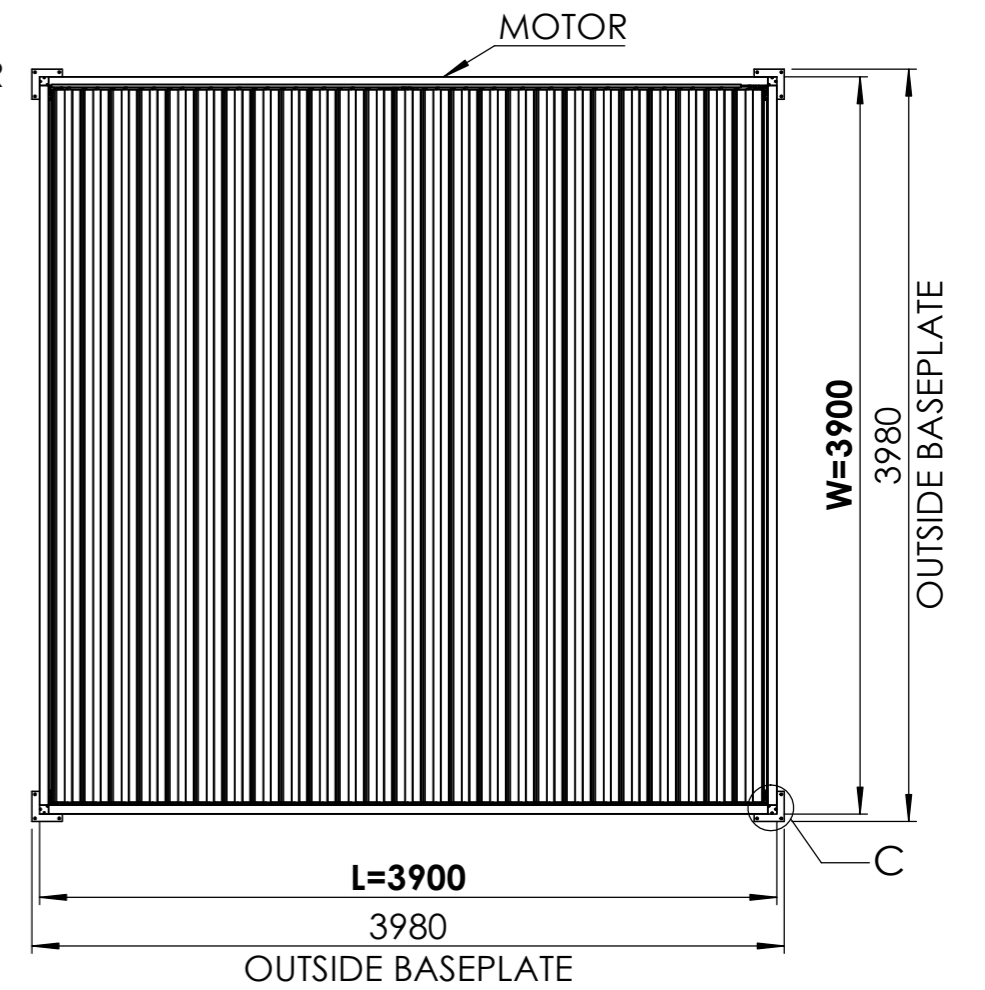

DETAIL A
OPEN POSITION

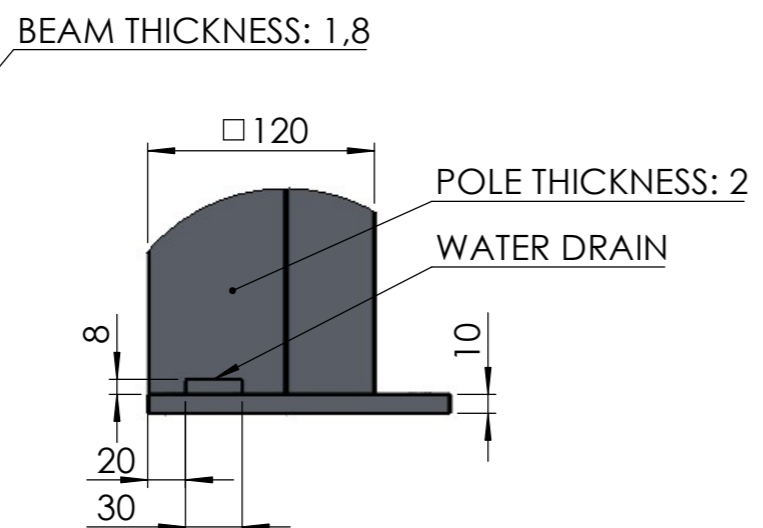

DETAIL B

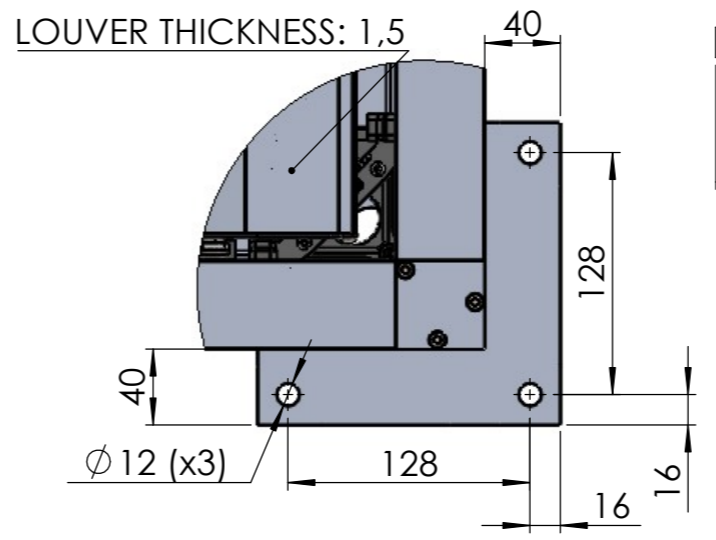

DETAIL C

PERGOLUX	
TITLE: P. PERGOLA V2 4X4 FREESTANDING	
WEIGHT: 243kg	
SKU: PER_MA_XXX_4X4_FRE_02	
PART NUMBER: PN-200000727	REVISION V2.1
DO NOT SCALE DRAWING	ALL DIMENSIONS ARE IN MILLIMETERS
	SHEET 1 OF 2

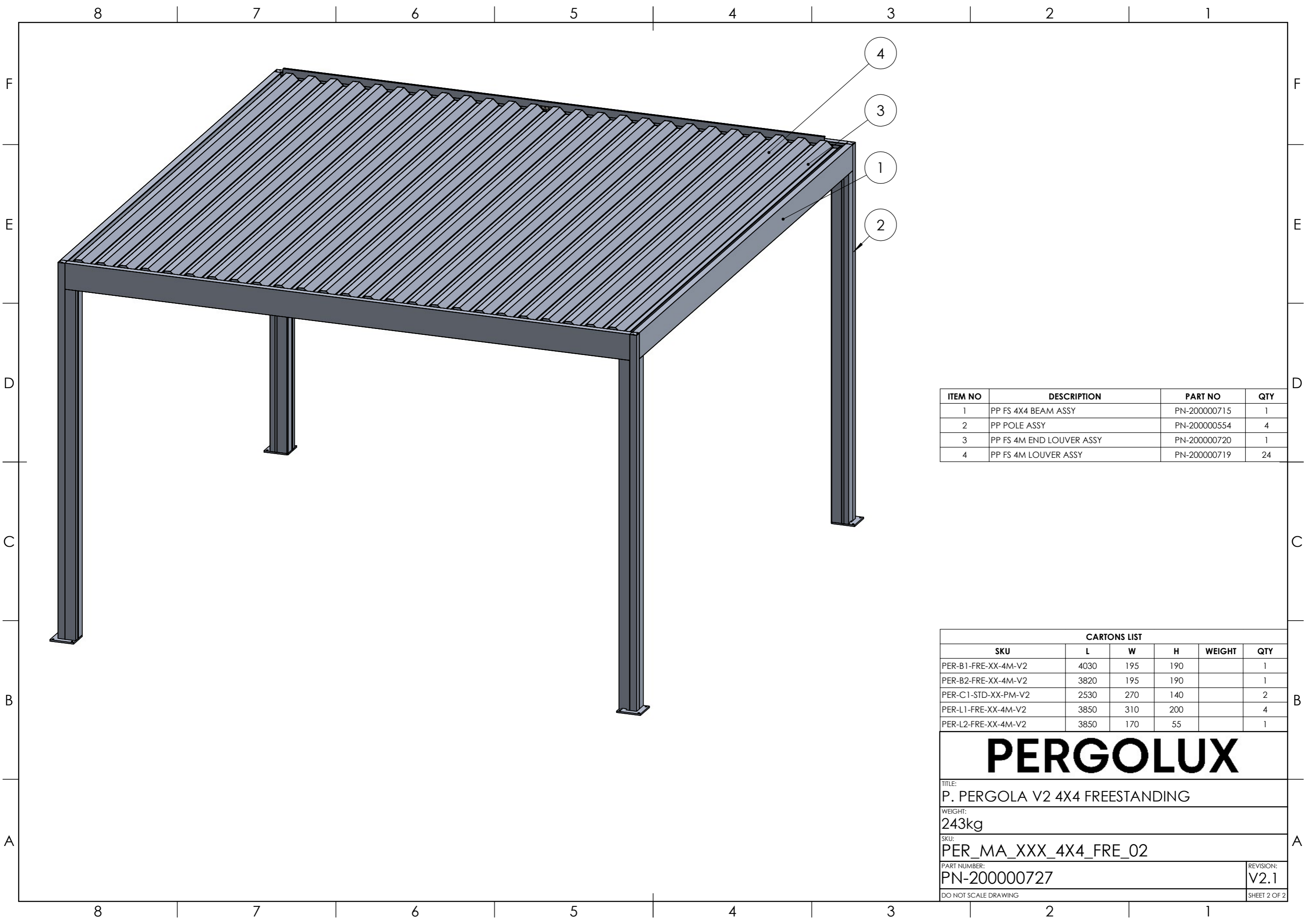

ITEM NO	DESCRIPTION	PART NO	QTY
1	PP FS 4X4 BEAM ASSY	PN-200000715	1
2	PP POLE ASSY	PN-200000554	4
3	PP FS 4M END LOUVER ASSY	PN-200000720	1
4	PP FS 4M LOUVER ASSY	PN-200000719	24

CARTONS LIST					
SKU	L	W	H	WEIGHT	QTY
PER-B1-FRE-XX-4M-V2	4030	195	190		1
PER-B2-FRE-XX-4M-V2	3820	195	190		1
PER-C1-STD-XX-PM-V2	2530	270	140		2
PER-L1-FRE-XX-4M-V2	3850	310	200		4
PER-L2-FRE-XX-4M-V2	3850	170	55		1

PERGOLUX

TITLE:
P. PERGOLA V2 4X4 FREESTANDING

WEIGHT:
243kg

SKU:
PER_MA_XXX_4X4_FRE_02

PART NUMBER: PN-200000727	REVISION: V2.1
------------------------------	-------------------

DO NOT SCALE DRAWING SHEET 2 OF 2

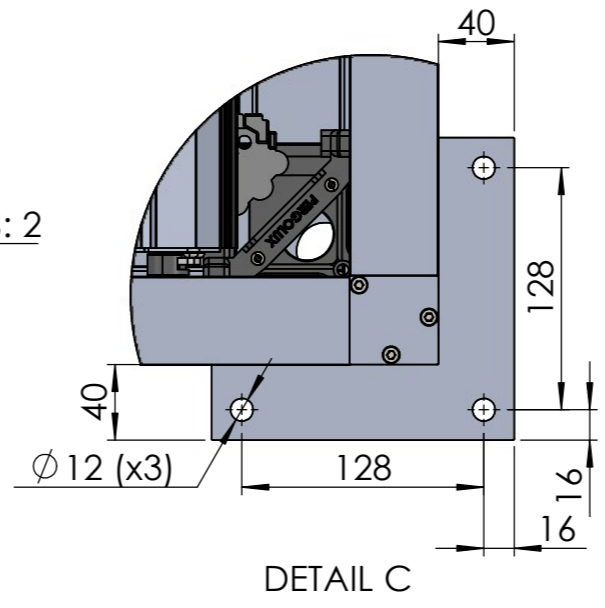
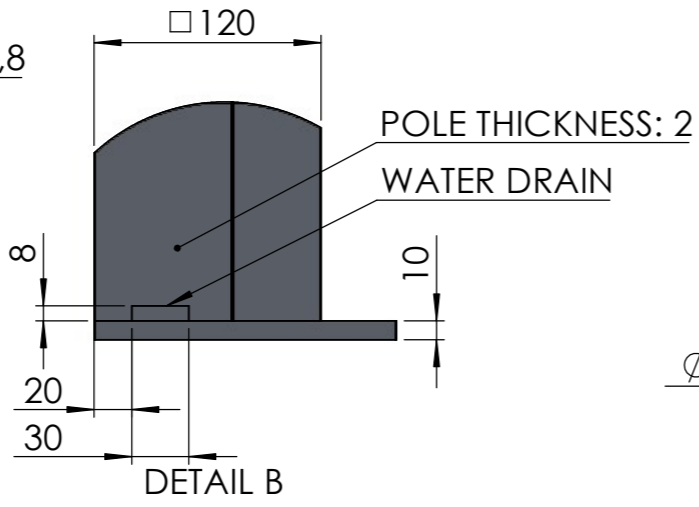
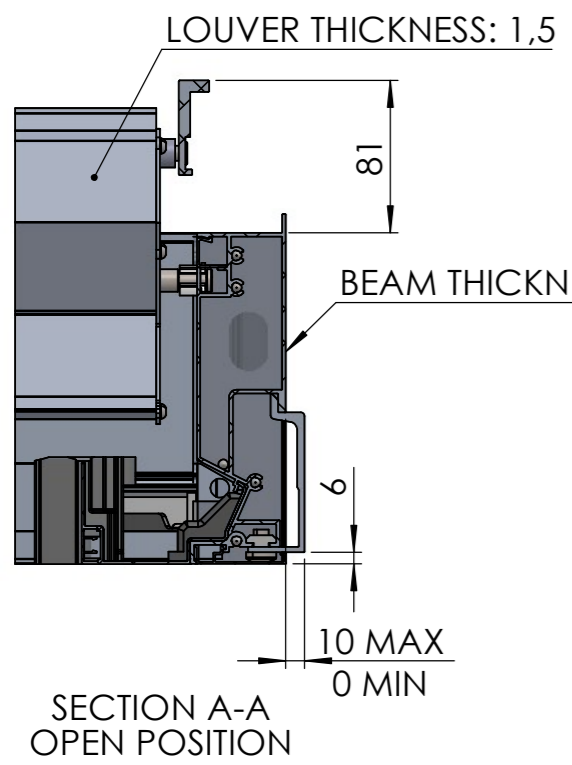
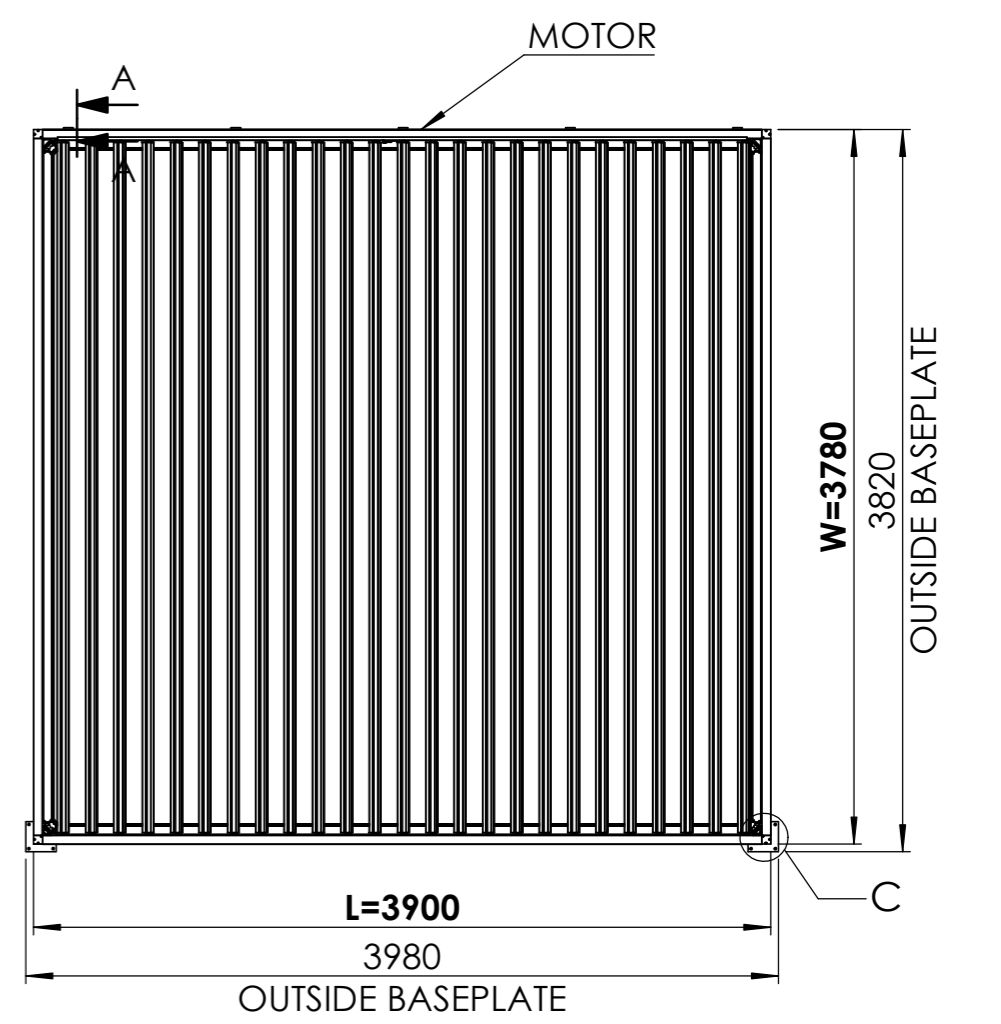
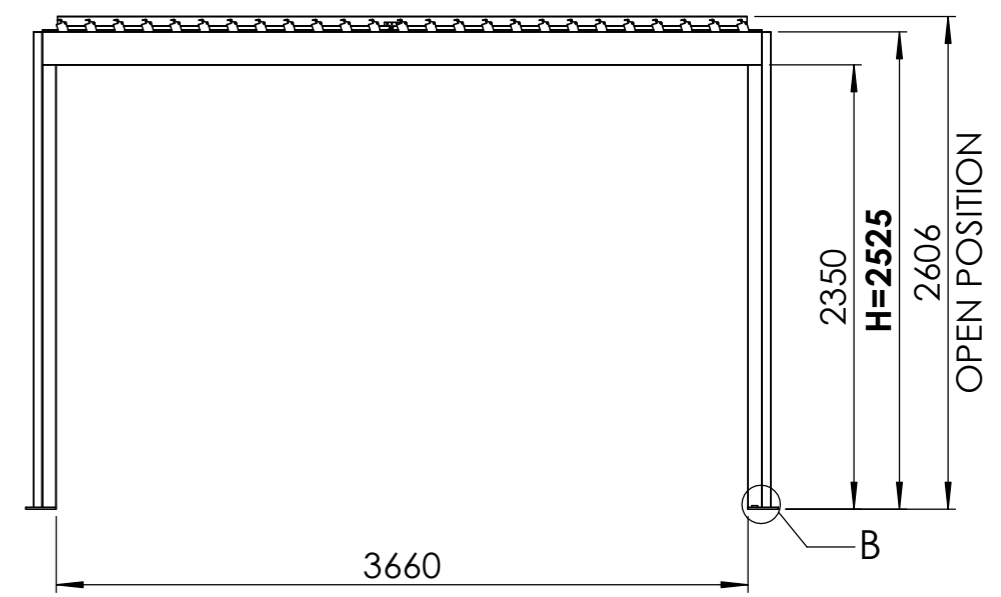
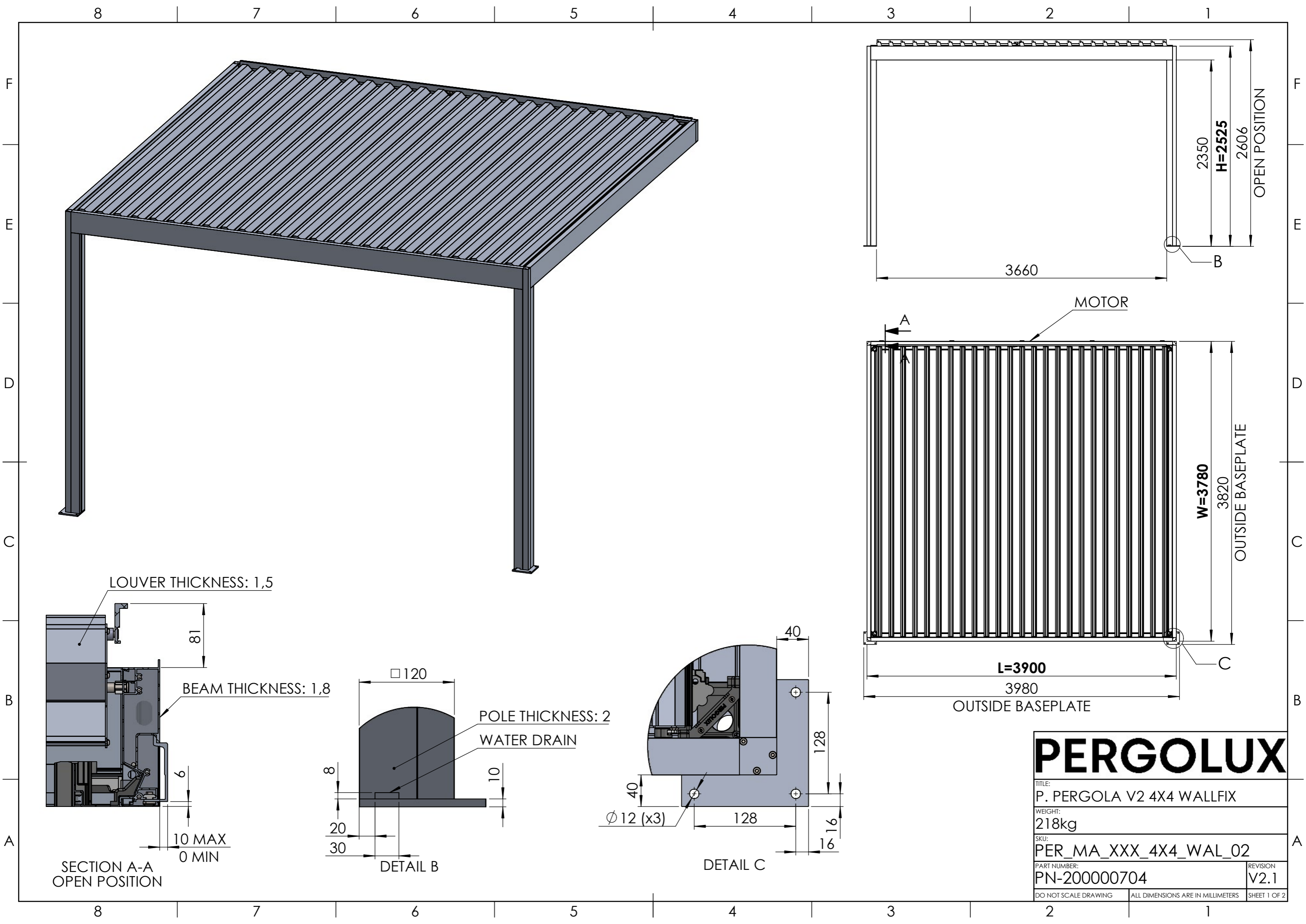

PERGOLUX	
TITLE: P. PERGOLA V2 4X4 WALLFIX	
WEIGHT: 218kg	
SKU: PER_MA_XXX_4X4_WAL_02	
PART NUMBER: PN-200000704	REVISION V2.1
DO NOT SCALE DRAWING	ALL DIMENSIONS ARE IN MILLIMETERS
SHEET 1 OF 2	

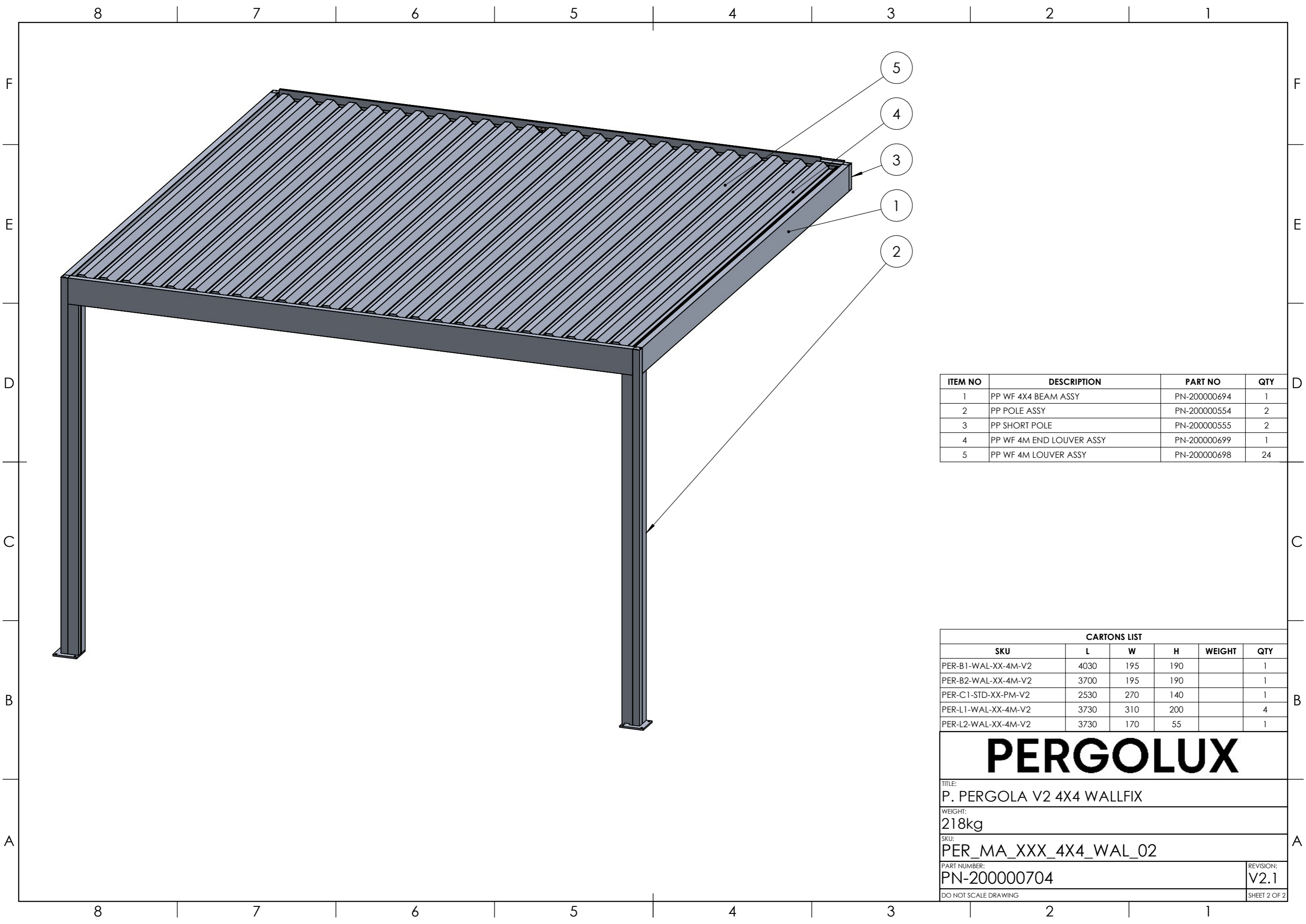

ITEM NO	DESCRIPTION	PART NO	QTY
1	PP WF 4X4 BEAM ASSY	PN-200000694	1
2	PP POLE ASSY	PN-200000554	2
3	PP SHORT POLE	PN-200000555	2
4	PP WF 4M END LOUVER ASSY	PN-200000699	1
5	PP WF 4M LOUVER ASSY	PN-200000698	24

CARTONS LIST					
SKU	L	W	H	WEIGHT	QTY
PER-B1-WAL-XX-4M-V2	4030	195	190		1
PER-B2-WAL-XX-4M-V2	3700	195	190		1
PER-C1-STD-XX-PM-V2	2530	270	140		1
PER-L1-WAL-XX-4M-V2	3730	310	200		4
PER-L2-WAL-XX-4M-V2	3730	170	55		1

PERGOLUX

TITLE:
P. PERGOLA V2 4X4 WALLFIX

WEIGHT:
218kg

SKU:
PER_MA_XXX_4X4_WAL_02

PART NUMBER:
PN-200000704

REVISION:
V2.1

DO NOT SCALE DRAWING

SHEET 2 OF 2

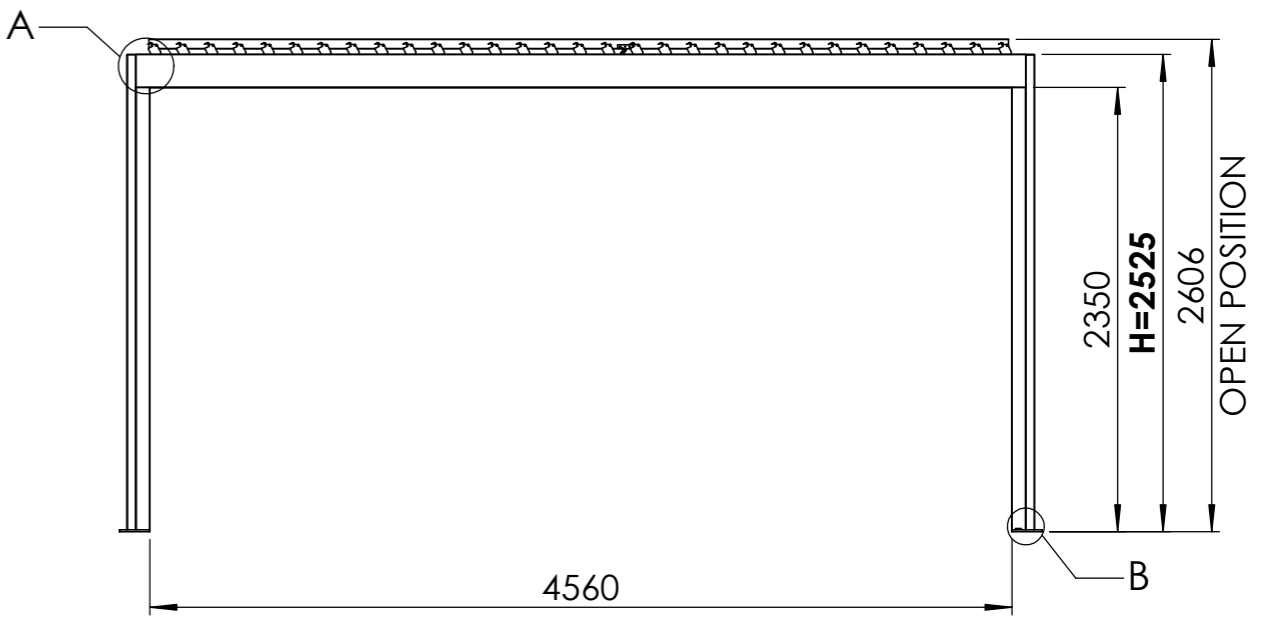

LOUVER
DRAIN
SLOPE

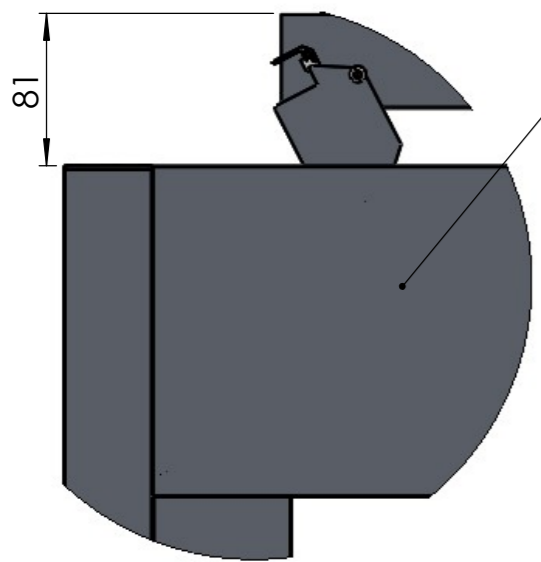
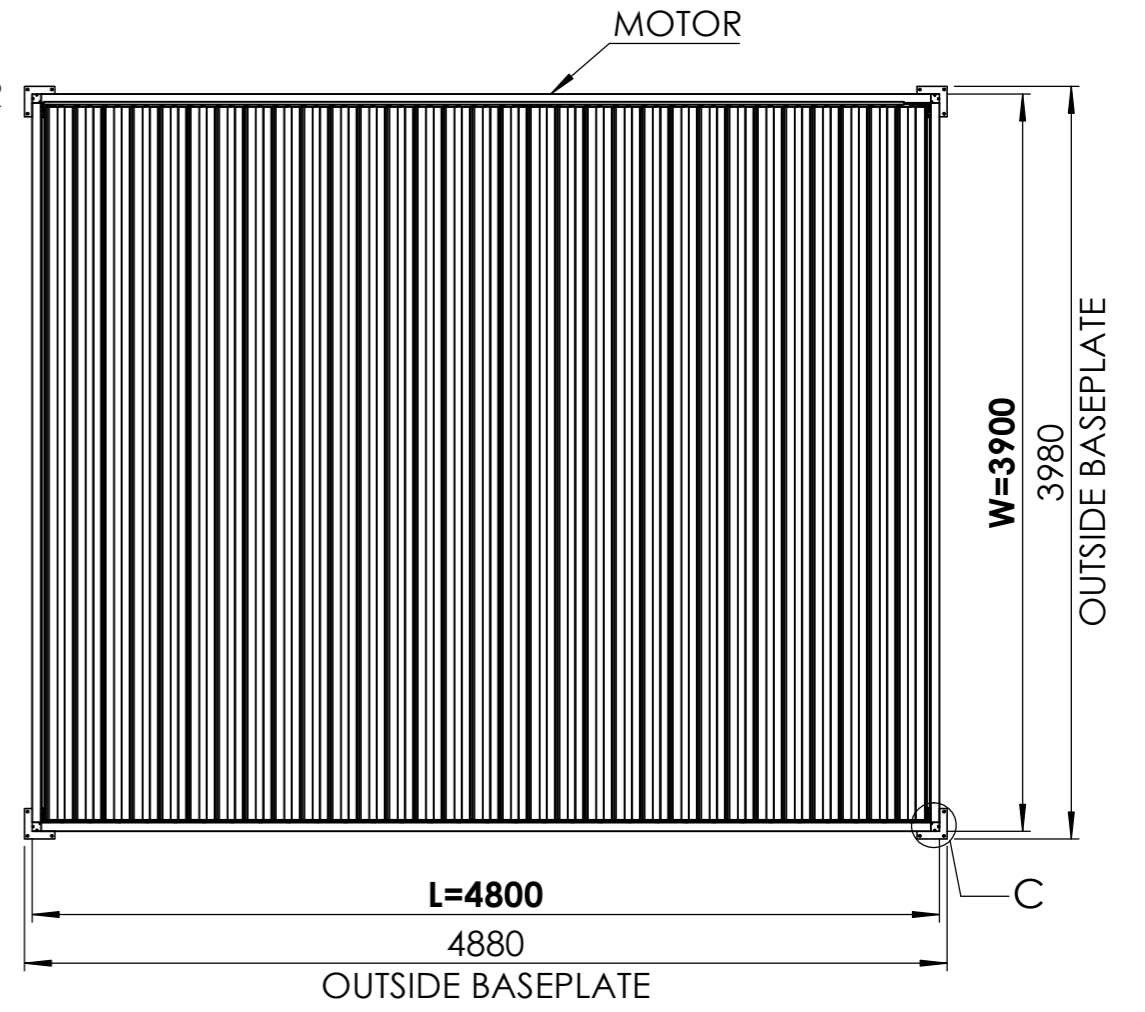

BEAM THICKNESS: 1,8

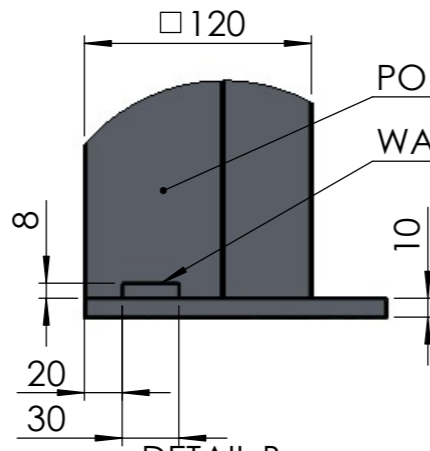

POLE THICKNESS: 2

WATER DRAIN

LOUVER THICKNESS: 1,5

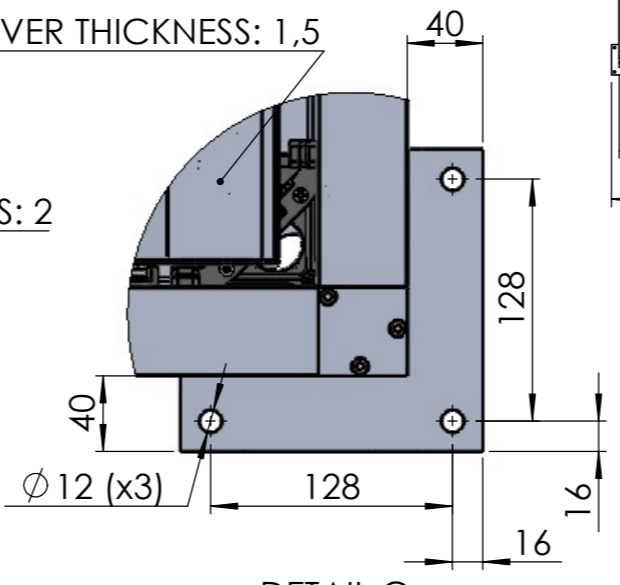

PERGOLUX

TITLE: P. PERGOLA V2 4X5 FREESTANDING	
WEIGHT: 282kg	
SKU: PER_MA_XXX_4X5_FRE_02	
PART NUMBER: PN-200000728	REVISION V2.1
DO NOT SCALE DRAWING	ALL DIMENSIONS ARE IN MILLIMETERS
SHEET 1 OF 2	

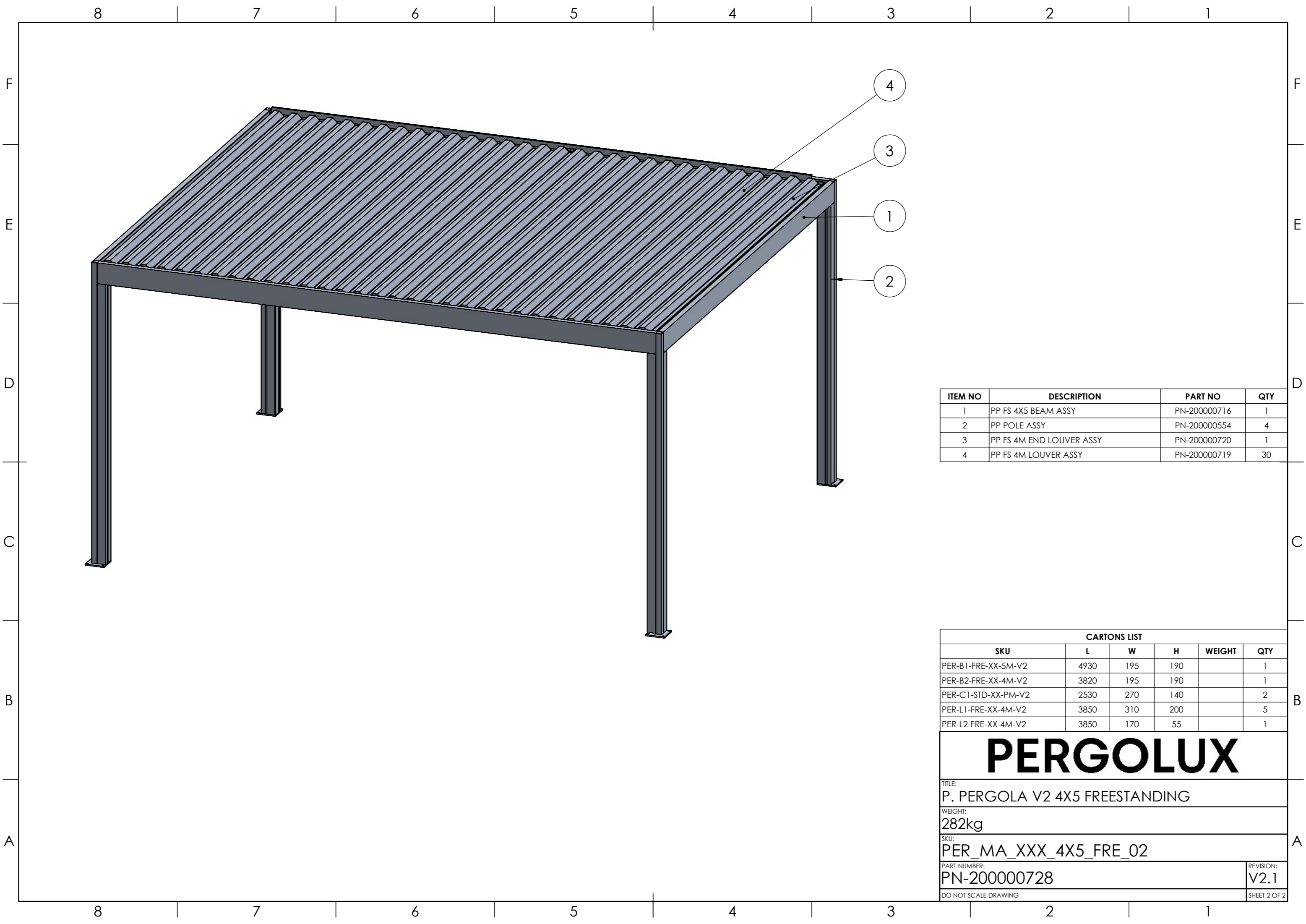

ITEM NO	DESCRIPTION	PART NO	QTY
1	PP FS 4X5 BEAM ASSY	PN-200000716	1
2	PP POLE ASSY	PN-200000554	4
3	PP FS 4M END LOUVER ASSY	PN-200000720	1
4	PP FS 4M LOUVER ASSY	PN-200000719	30

CARTONS LIST					
SKU	L	W	H	WEIGHT	QTY
PER-B1-FRE-XX-5M-V2	4930	195	190		1
PER-B2-FRE-XX-4M-V2	3820	195	190		1
PER-C1-STD-XX-PM-V2	2530	270	140		2
PER-L1-FRE-XX-4M-V2	3850	310	200		5
PER-L2-FRE-XX-4M-V2	3850	170	55		1

PERGOLUX

TITLE:
P. PERGOLA V2 4X5 FREESTANDING

WEIGHT:
282kg

SKU:
PER_MA_XXX_4X5_FRE_02

PART NUMBER:
PN-200000728

REVISION:
V2.1

DO NOT SCALE DRAWING

SHEET 2 OF 2

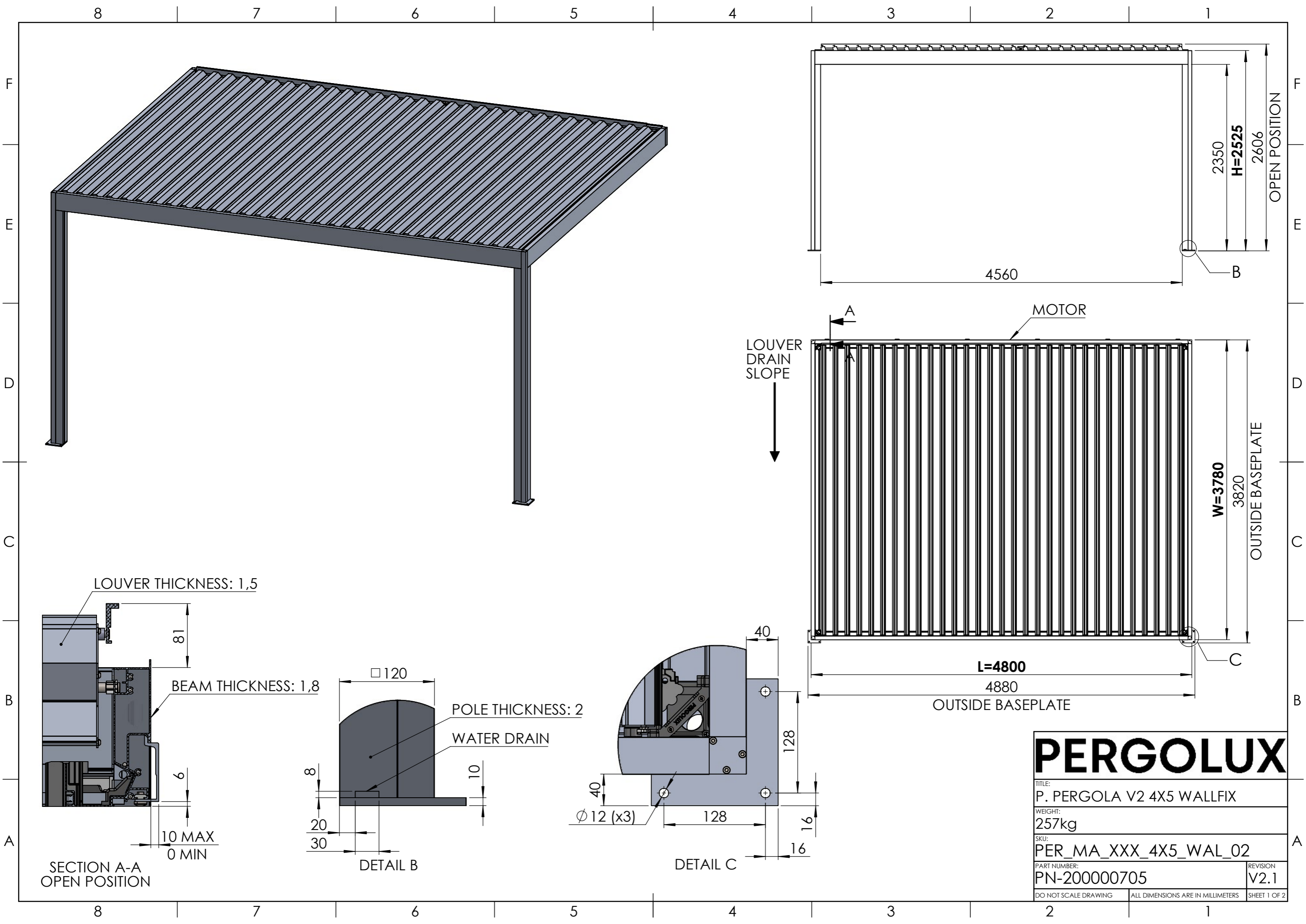

PERGOLUX

TITLE: P. PERGOLA V2 4X5 WALLFIX	
WEIGHT: 257kg	
SKU: PER_MA_XXX_4X5_WAL_02	
PART NUMBER: PN-200000705	REVISION V2.1
DO NOT SCALE DRAWING	ALL DIMENSIONS ARE IN MILLIMETERS
	SHEET 1 OF 2

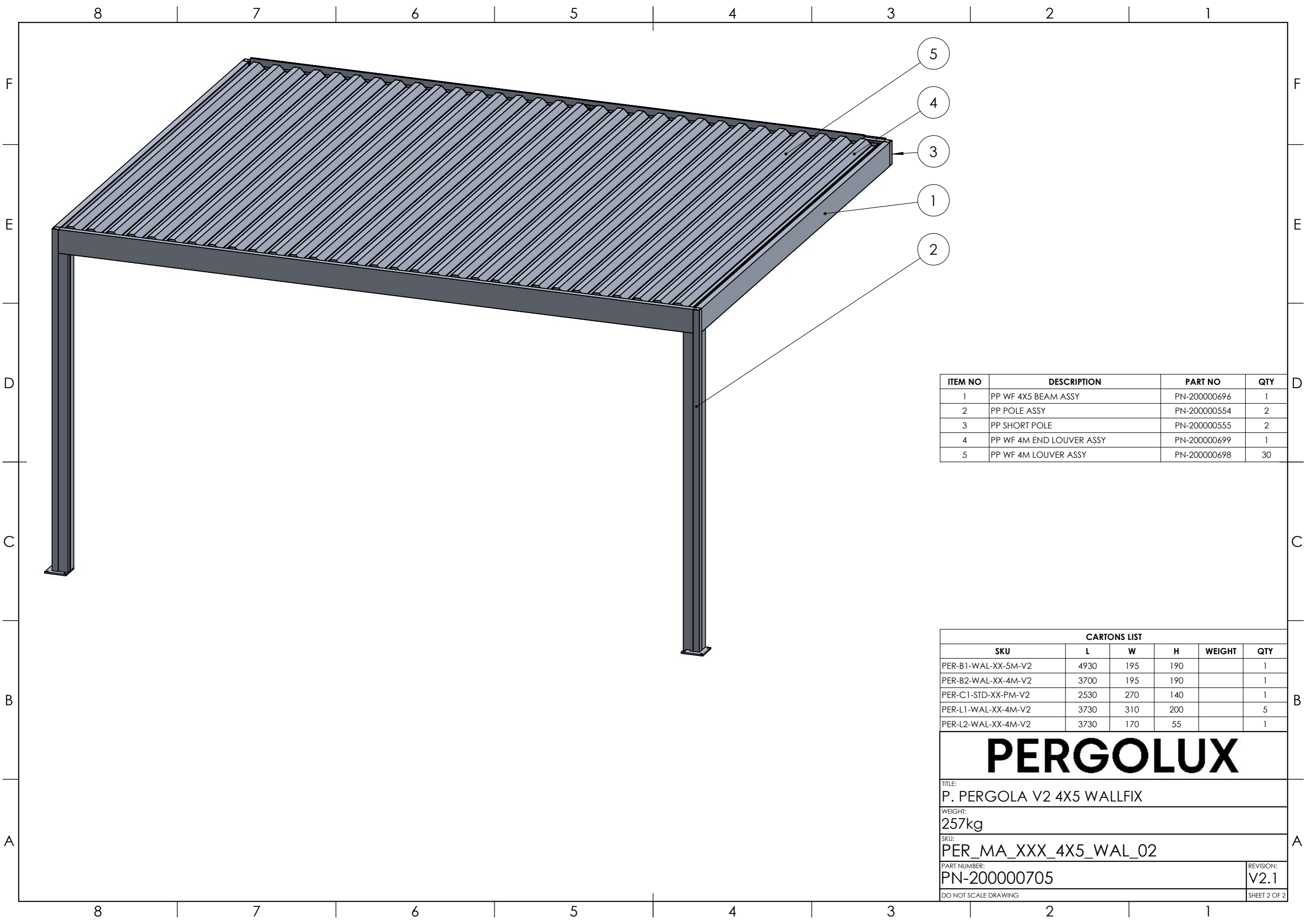

ITEM NO	DESCRIPTION	PART NO	QTY
1	PP WF 4X5 BEAM ASSY	PN-200000696	1
2	PP POLE ASSY	PN-200000554	2
3	PP SHORT POLE	PN-200000555	2
4	PP WF 4M END LOUVER ASSY	PN-200000699	1
5	PP WF 4M LOUVER ASSY	PN-200000698	30

CARTONS LIST					
SKU	L	W	H	WEIGHT	QTY
PER-B1-WAL-XX-5M-V2	4930	195	190		1
PER-B2-WAL-XX-4M-V2	3700	195	190		1
PER-C1-STD-XX-PM-V2	2530	270	140		1
PER-L1-WAL-XX-4M-V2	3730	310	200		5
PER-L2-WAL-XX-4M-V2	3730	170	55		1

PERGOLUX

TITLE:
P. PERGOLA V2 4X5 WALLFIX

WEIGHT:
257kg

SKU:
PER_MA_XXX_4X5_WAL_02

PART NUMBER: PN-200000705	REVISION: V2.1
-------------------------------------	--------------------------

DO NOT SCALE DRAWING SHEET 2 OF 2

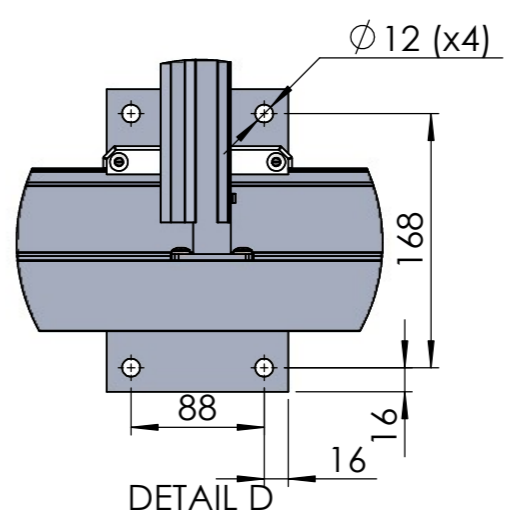
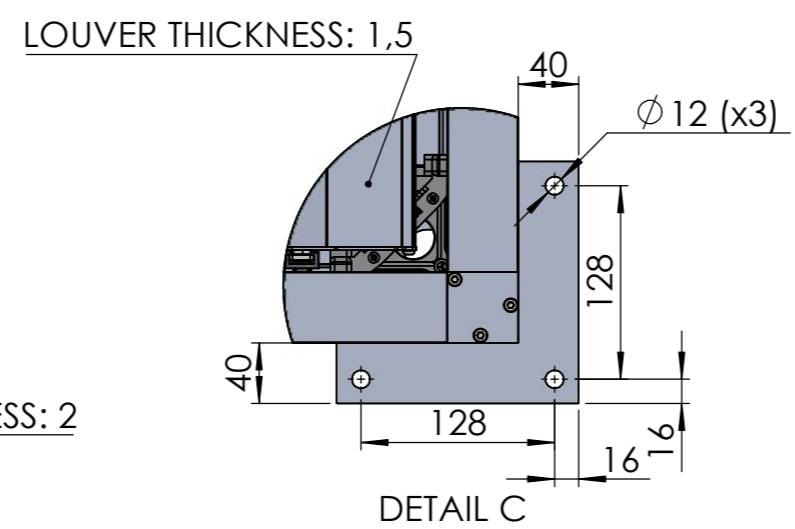
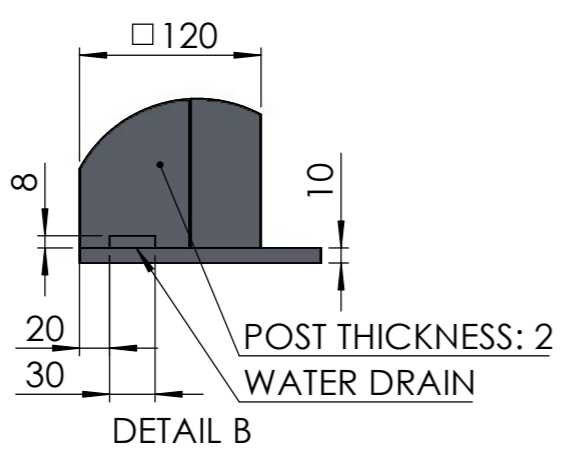
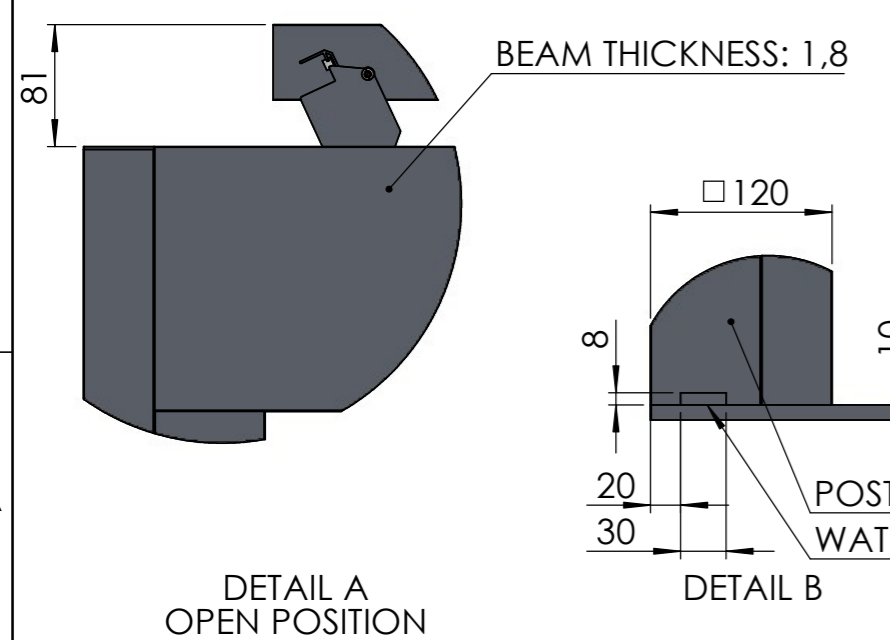
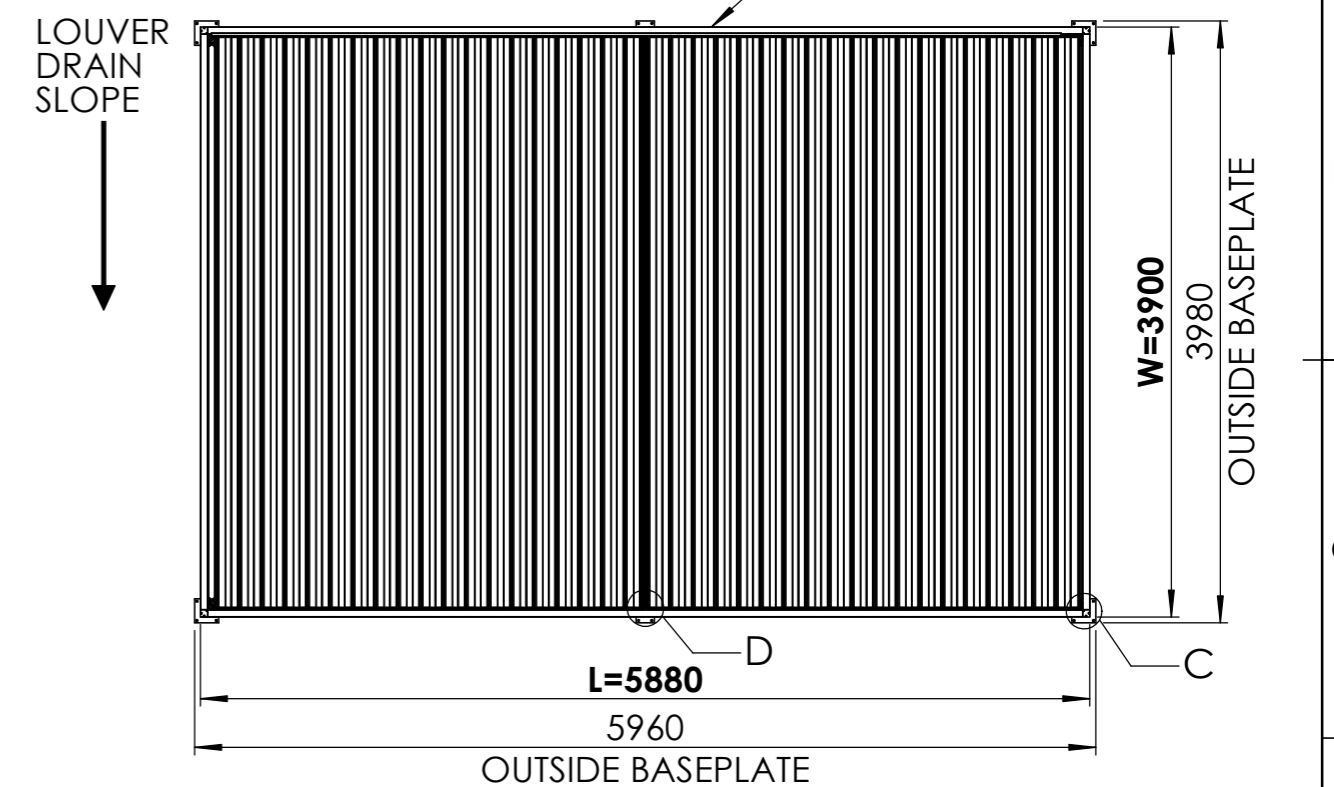
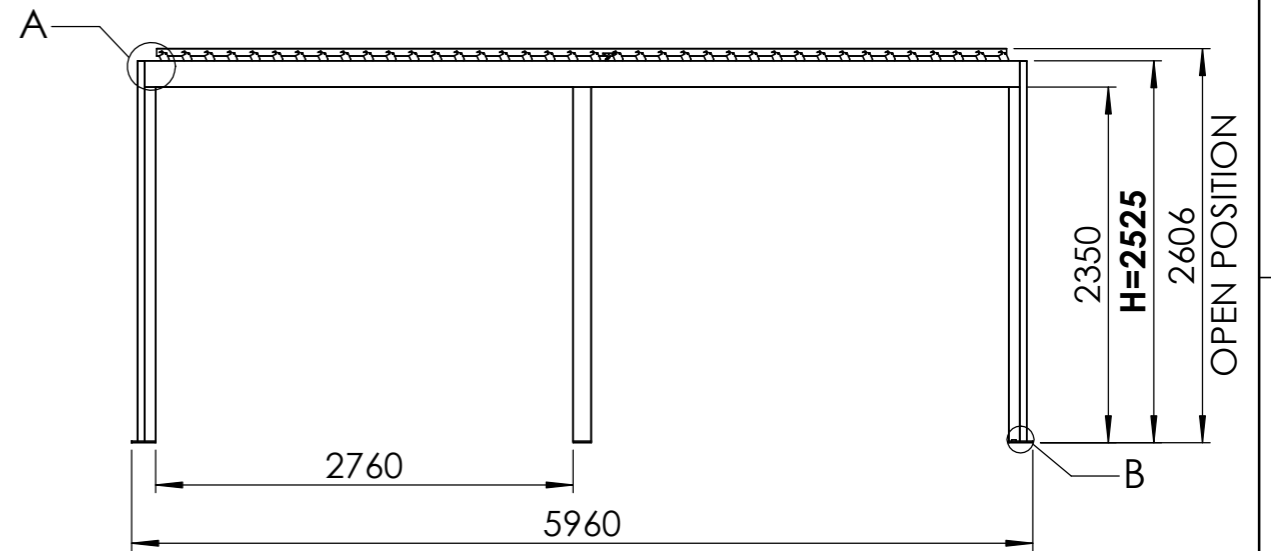

PERGOLUX		
TITLE: P. PERGOLA V2 4X6 FREESTANDING		
WEIGHT: 352kg		
SKU: PER_MA_XXX_4X6_FRE_02		
PART NUMBER: PN-200000751		REVISION: 0.1
DO NOT SCALE DRAWING	ALL DIMENSIONS ARE IN MILLIMETERS	SHEET 1 OF 2

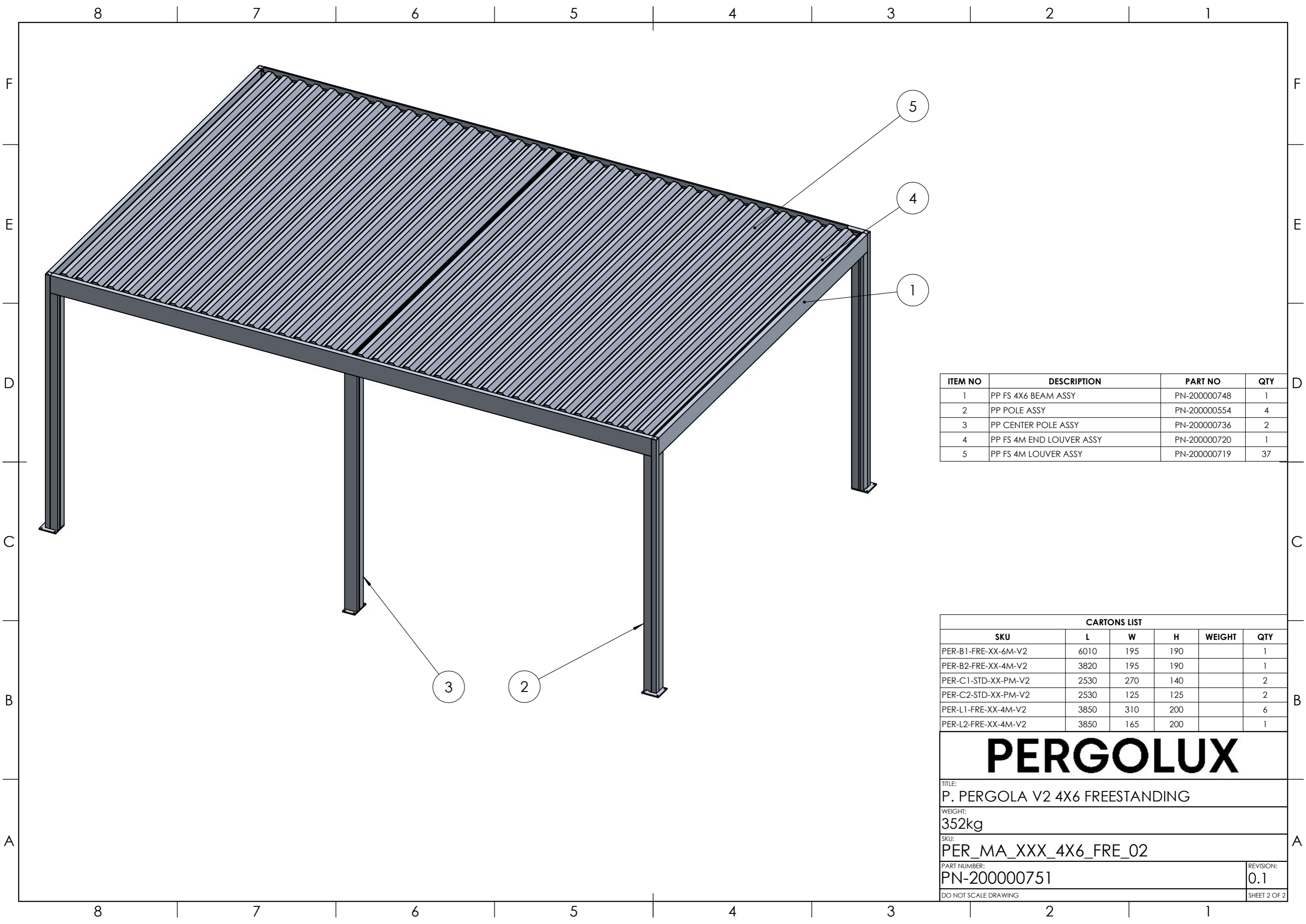

ITEM NO	DESCRIPTION	PART NO	QTY
1	PP FS 4X6 BEAM ASSY	PN-200000748	1
2	PP POLE ASSY	PN-200000554	4
3	PP CENTER POLE ASSY	PN-200000736	2
4	PP FS 4M END LOUVER ASSY	PN-200000720	1
5	PP FS 4M LOUVER ASSY	PN-200000719	37

CARTONS LIST					
SKU	L	W	H	WEIGHT	QTY
PER-B1-FRE-XX-6M-V2	6010	195	190		1
PER-B2-FRE-XX-4M-V2	3820	195	190		1
PER-C1-STD-XX-PM-V2	2530	270	140		2
PER-C2-STD-XX-PM-V2	2530	125	125		2
PER-L1-FRE-XX-4M-V2	3850	310	200		6
PER-L2-FRE-XX-4M-V2	3850	165	200		1

PERGOLUX

TITLE:
P. PERGOLA V2 4X6 FREESTANDING

WEIGHT:
352kg

SKU:
PER_MA_XXX_4X6_FRE_02

PART NUMBER: PN-200000751	REVISION: 0.1
-------------------------------------	-------------------------

DO NOT SCALE DRAWING SHEET 2 OF 2

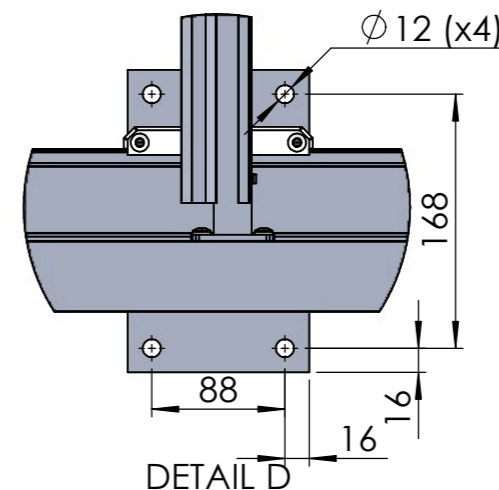
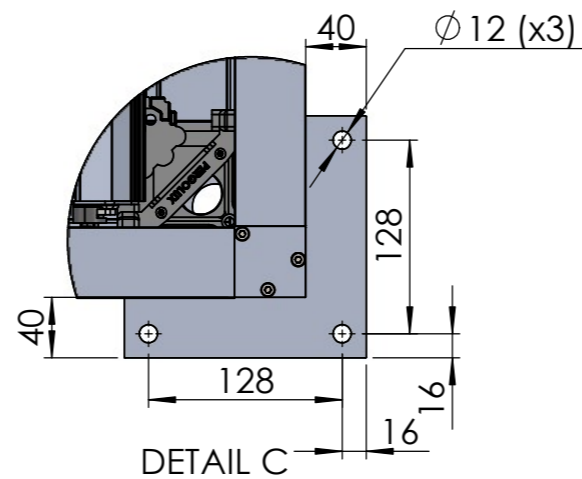
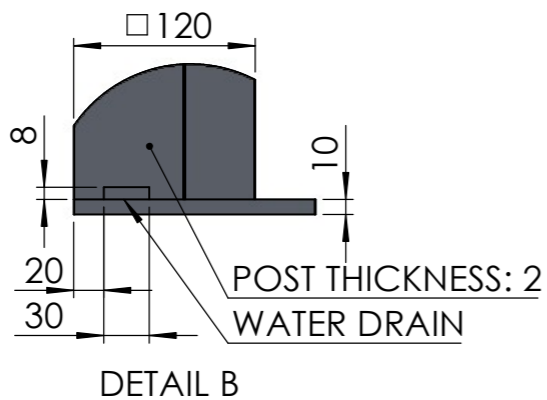
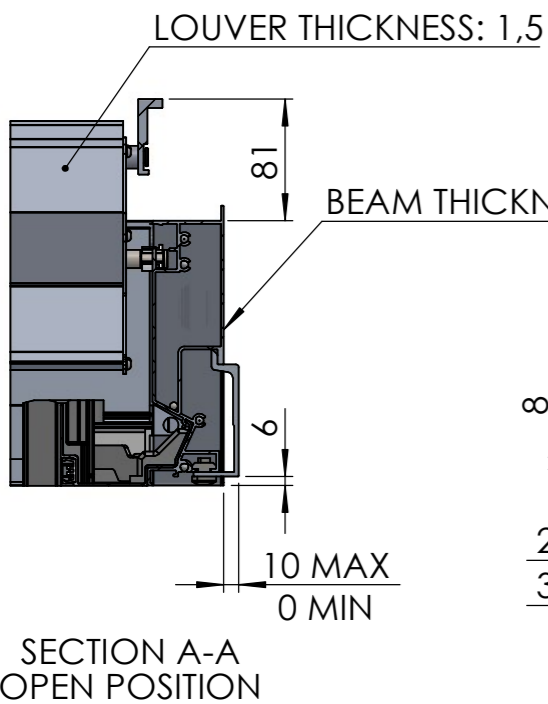
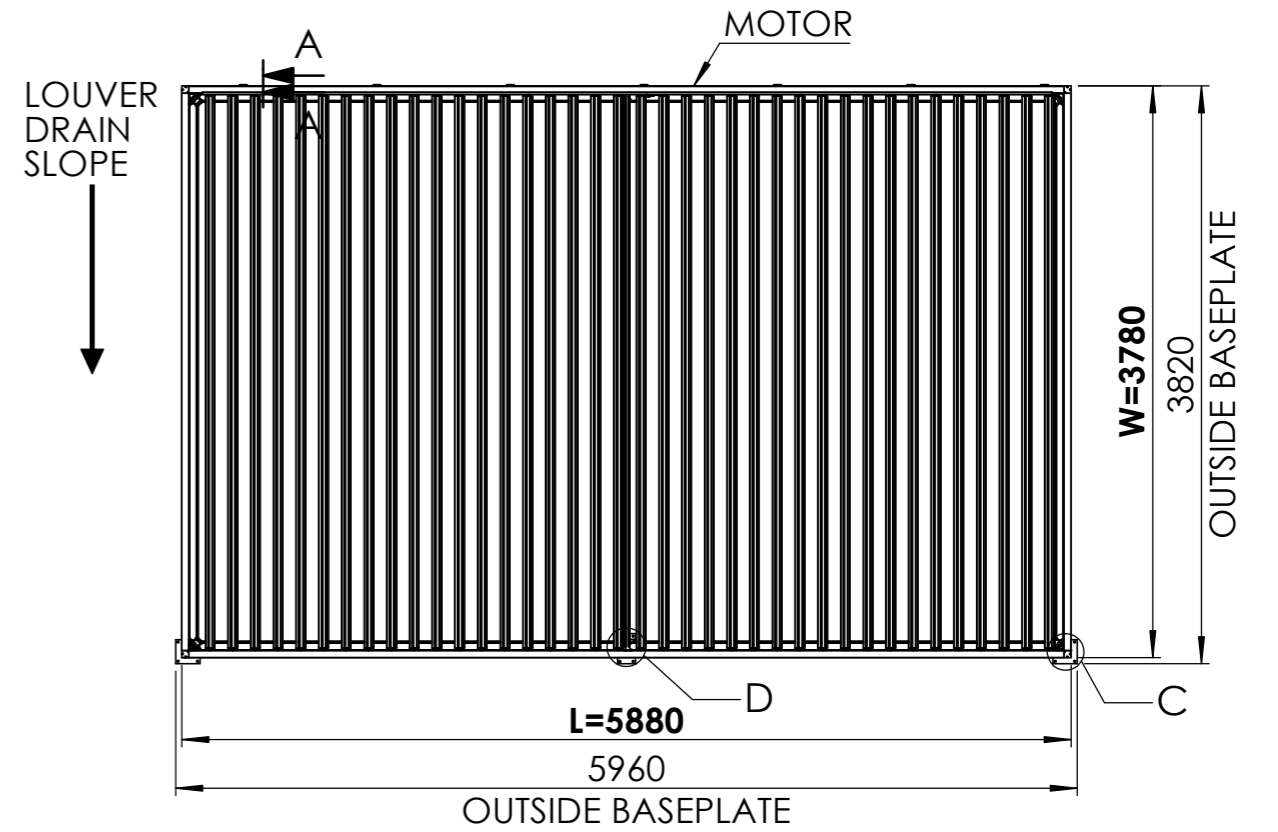
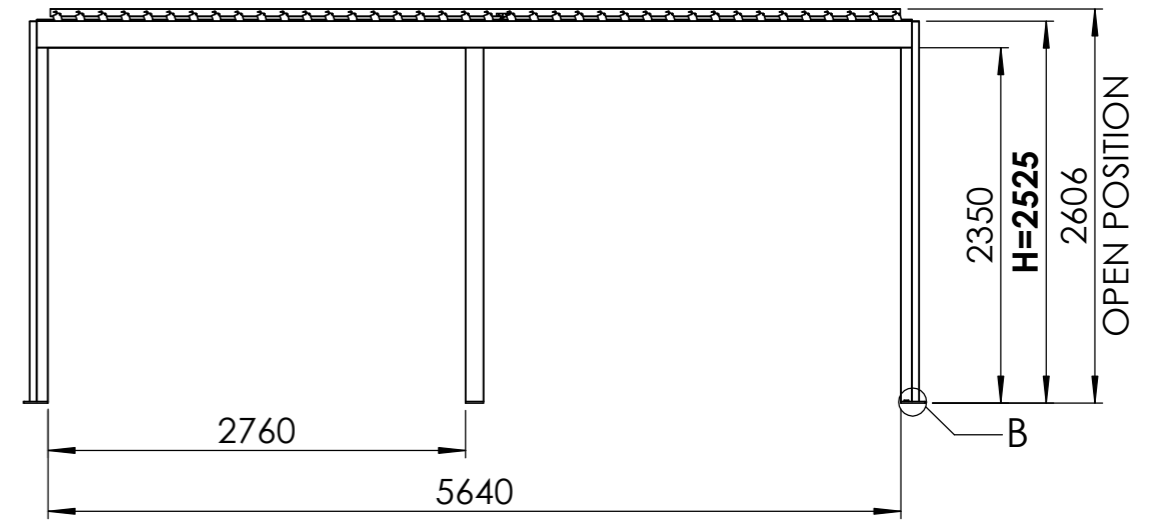

PERGOLUX	
TITLE: P. PERGOLA V2 4X6 WALLFIXED	
WEIGHT: 316kg	
SKU: PER_MA_XXX_4X6_WAL_02	
PART NUMBER: PN-200000760	REVISION: 0.1
DO NOT SCALE DRAWING	ALL DIMENSIONS ARE IN MILLIMETERS
SHEET 1 OF 2	

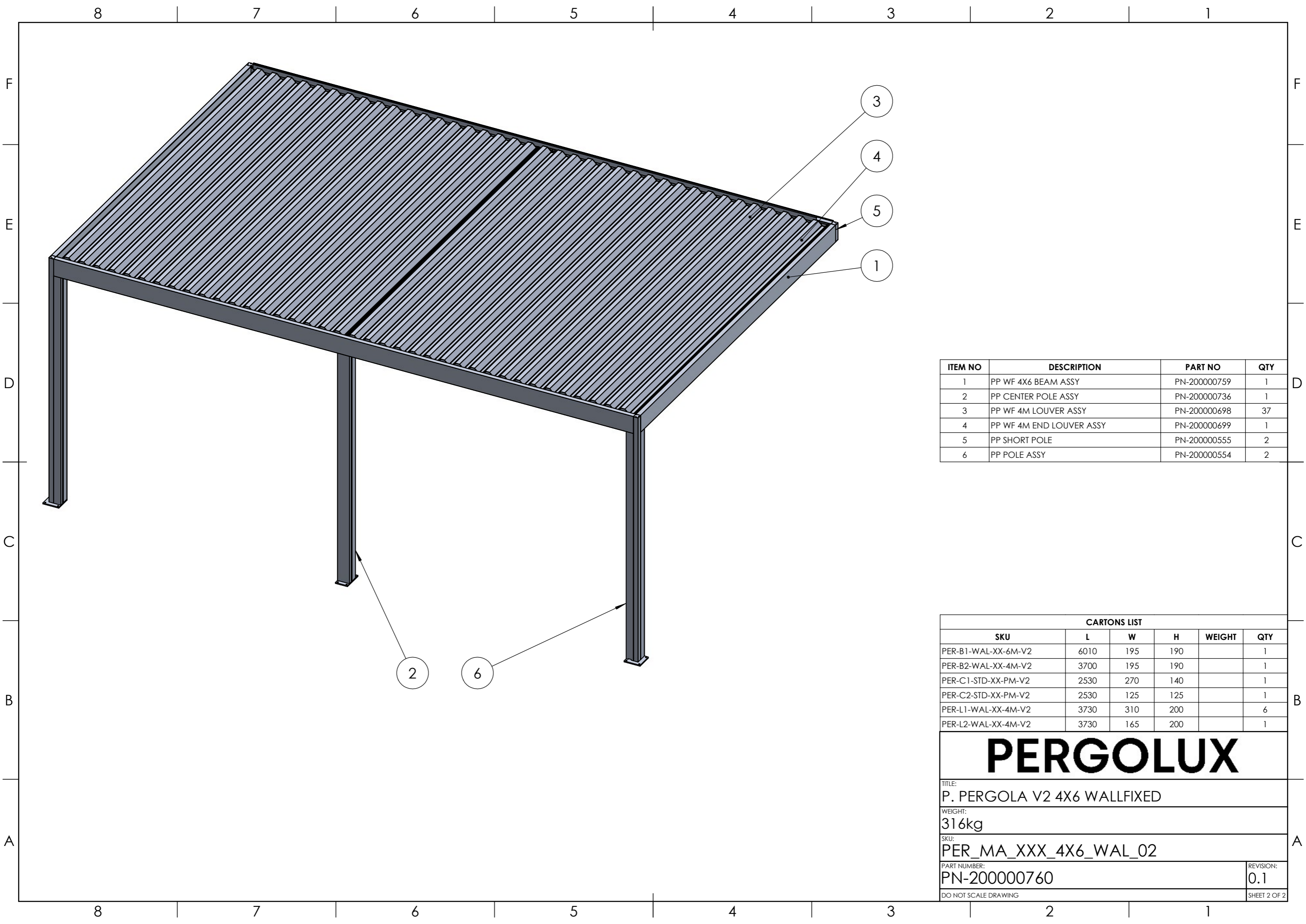

ITEM NO	DESCRIPTION	PART NO	QTY
1	PP WF 4X6 BEAM ASSY	PN-200000759	1
2	PP CENTER POLE ASSY	PN-200000736	1
3	PP WF 4M LOUVER ASSY	PN-200000698	37
4	PP WF 4M END LOUVER ASSY	PN-200000699	1
5	PP SHORT POLE	PN-200000555	2
6	PP POLE ASSY	PN-200000554	2

CARTONS LIST					
SKU	L	W	H	WEIGHT	QTY
PER-B1-WAL-XX-6M-V2	6010	195	190		1
PER-B2-WAL-XX-4M-V2	3700	195	190		1
PER-C1-STD-XX-PM-V2	2530	270	140		1
PER-C2-STD-XX-PM-V2	2530	125	125		1
PER-L1-WAL-XX-4M-V2	3730	310	200		6
PER-L2-WAL-XX-4M-V2	3730	165	200		1

PERGOLUX

TITLE:
P. PERGOLA V2 4X6 WALLFIXED

WEIGHT:
316kg

SKU:
PER_MA_XXX_4X6_WAL_02

PART NUMBER: PN-200000760	REVISION: 0.1
-------------------------------------	-------------------------

DO NOT SCALE DRAWING SHEET 2 OF 2