

Name: _____
 Company name: _____
 Job Name: _____
 Phone: _____
 E-mail: _____
 Location: _____
 Building code: _____

Is PE Stamp required? Yes No
 Can we penetrate roof? Yes No
 AutoCAD/Revit file available? Yes No
 Windload: _____ MPH

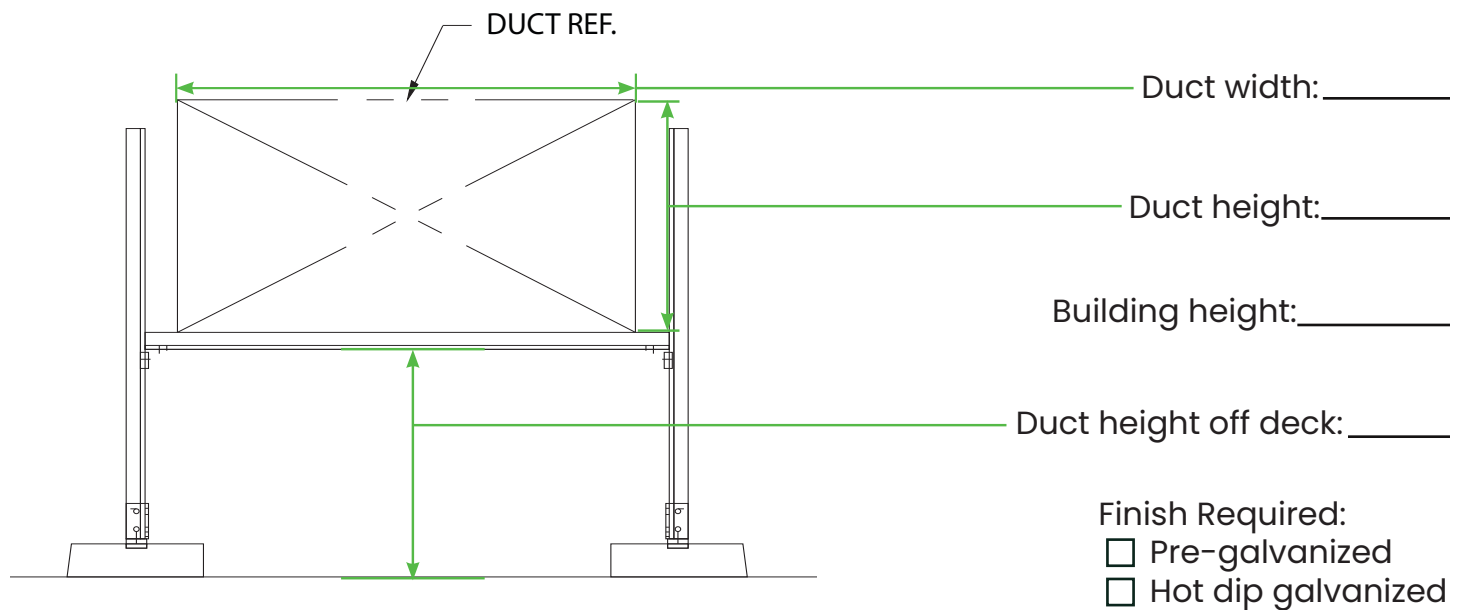

PRODUCT DESCRIPTION

Duct supports are an ideal choice for lifting, stabilizing and supporting rooftop ductwork and tubing. Unistrut Service Company’s heavy-duty roof duct supports protect against roof leaks and property damage while safeguarding your commercial HVAC systems. Made in the USA.

PRODUCT REQUIREMENTS

Maximum clearance: 48"
 Load limit is dependent on building code

PRODUCT FEATURES

- Non-penetrating concrete base design minimizes the number of roof penetrations required to achieve the desired wind load rating.
- Each duct support comes with two rubber pads to create a protective barrier between concrete base plate and roof surface
- Standard Finish – 12 GA. Hot Dipped Galvanized channel conforming to ASTM A653 G90
- Custom sizes are also available upon request
- Stainless steel available upon request