

S-5![®]

The Right Way!

The right way to attach almost anything to metal roofs!

Installation Instructions

Stop! Has your snow retention system been designed properly with the assistance of a distributor?

Notice to S-5![®] product users: Specific layout and assembly schematics for S-5! products are the responsibility of the user or project designer. Due to the many variables involved with specific panel products, climates, snow melt phenomena, and job particulars, the manufacturer cannot and does not express any opinions as to the suitability of any S-5! assembly for any specific application and assumes no liability with respect thereto. S-5! clamps are tested for ultimate holding strength on various seam types and materials. This information is available from S-5! distributors as well as from the S-5! website: www.S-5.com. This document is an installation guide only and the photographs and drawings herein are for the purpose of illustrating installation, tools and techniques, not system designs. Read entire install instructions prior to installation. Clamp spacing should never exceed 48" or limits determined by the project designer (whichever is lower).

Tools Needed

- Screw Gun*
- String Line
- Reciprocating Saw
- 1/8" Allen Bit Tip
- Calibrated Torque Wrench
- Tape Measure
- 3/16" Allen Bit Tip
- 1/2" (13mm) Hex Socket Bit
- (provided with clamps)

(For accurate tension values, do NOT use a clicking torque wrench)

***For time saving tool recommendations contact S-5!**

To Install DualGard[™]

Before You Start: S-5! Mini attachment clamps are installed differently depending upon clamp model and seam style. Please see the installation instructions included with your clamps.

Step 1 : Preparing the assembly

It is recommended to pre-load the set screws into each clamp and DualCollar[™] prior to commencing installation.

DualGard uses two S-5 Mini clamps at each pipe bracket location. One of these clamps should be fastened to the pipe bracket on what will become the upslope side (Fig. 1). Verify which side of the standing seam the set screws will be applied to, and keep this in mind when bolting them to the pipe brackets. Hand tighten the M8 bolts attaching the clamps to the DualGard brackets.

Notice: When using S-5-U mini or S-5-H90 Mini clamps on horizontal seams, clamps cannot be pre-attached to brackets.

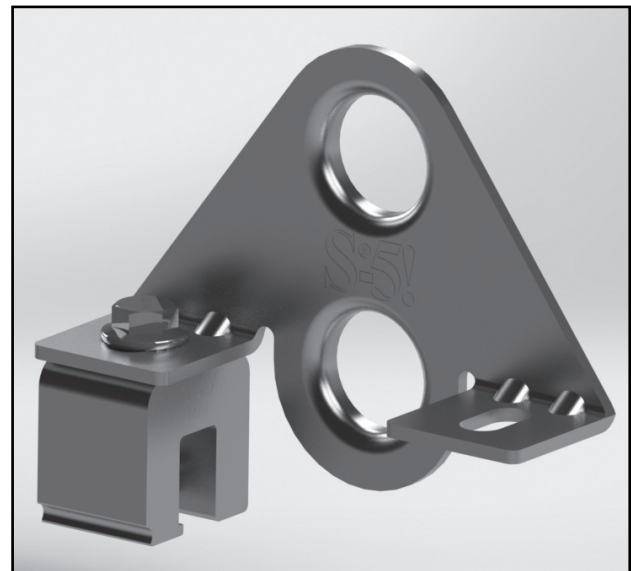

Fig. 1: Upslope clamp mounted to DualGard bracket

Installation Tip: To ensure the brackets line up, it is advisable to use a string line. This is best achieved by measuring up from the eave at each end of the run you are working on. Install a clamp at either end, wrap a string line around each of these clamps and pull it tight. Install the remaining clamps along this string line and your brackets will align with one another.

These instructions are for use by those experienced in the trade. Always follow appropriate safety precautions and use appropriate tools.

DualGard Installation Instructions

Step 2 : Install the first row of S-5 Mini clamps

This row of clamps will support the downslope end of the DualGard bracket. Using the string line method outlined above to align the clamps (Fig. 2), tighten each set screw to the appropriate recommended torque specification (see table below). Set the M8 bolts provided with the clamps aside for use later. If utilizing S-5-U Mini or S-5-H90 mini for horizontal seams, install the upslope clamps now.

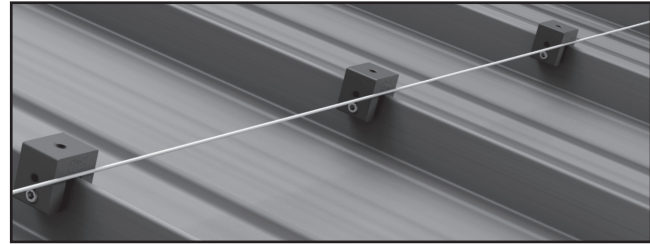

Fig. 2: Downslope row of clamps installed along string line

Specified Clamp Set Screw Torque	Inch Pounds	Foot Pounds	Newton meters
22 ga steel	160-180	13-15	18-20
All other metals and thinner gages of steel	130-150	11-12.5	15-17

Step 3: Prepare pipe/bracket/clamp assembly

Slide the correct number of DualGard brackets onto the 8 ft pipes (Fig. 3). Trim either one of the first two pipes so that the connection points between pipes do not align. On the first pipe & bracket assembly, a DualCollar should be fastened onto the top and bottom pipes no more than 7" from the ends of the pipes, with the first DualGard bracket and clamp placed just outside of the collars (Fig. 4). The maximum allowable cantilever for DualPipe™ is 6 inches; setting the DualCollars at 7" allows for a 1" gap between the collars and the first DualGard bracket to provide relief for thermal movement. On the last pipe & bracket assembly, a DualCollar should be slid onto the top and bottom pipes just inside of the last bracket and left loose at this point.

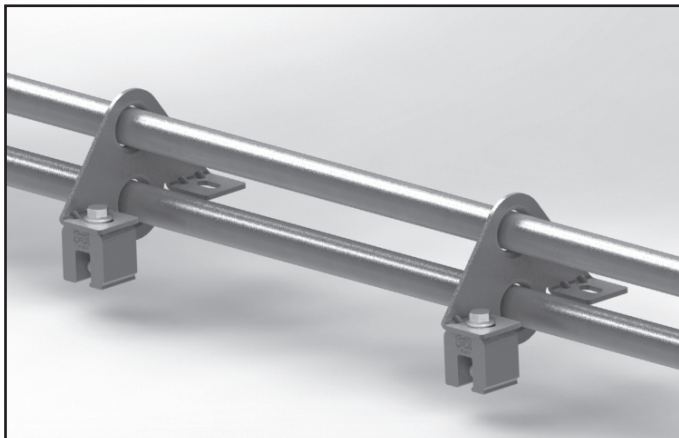

Fig. 3: 1" pipes with DualGard brackets and upslope clamps

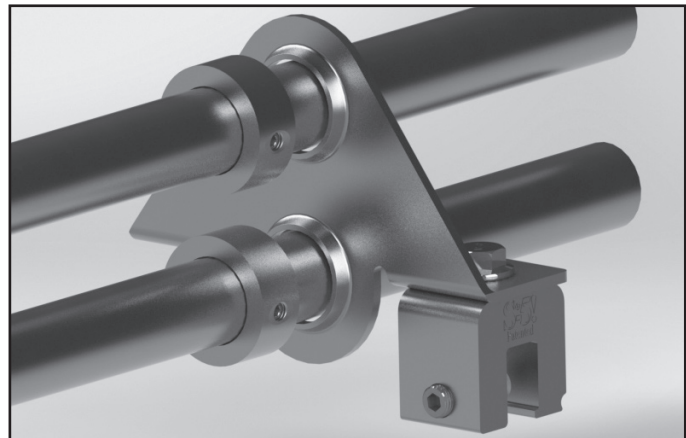

Fig. 4: DualCollars installed 1" inside of first bracket

Step 4: Attach the second row of S-5 Mini Clamps with attached pipe brackets

Place the pre-assembled section of pipe & brackets on the roof, aligning each bracket with the clamps installed in step 2 (Fig. 5). Bolt the pipe bracket to the downslope clamp using the provided M8 bolts and a 1/2" (13 mm) wrench or socket to the recommended torque specification of 156 inch pounds (13 foot pounds). Tighten the set screw on the upslope clamp, then tighten the bolt.

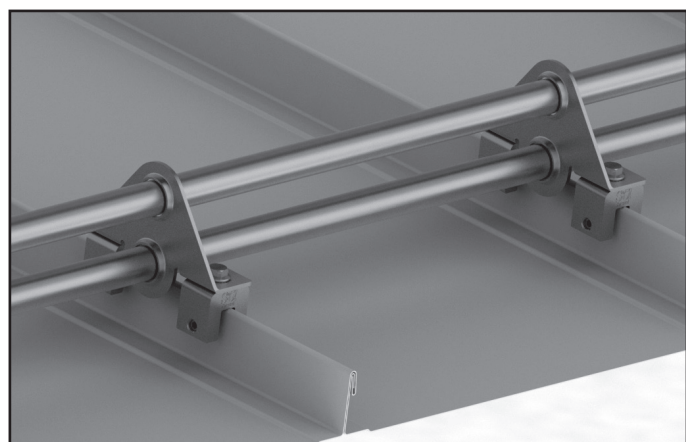

Fig. 5: Pre-assembled pipe and brackets installed on clamps

S-5!® Warning! Please use this product responsibly!

Products are protected by multiple U.S. and foreign patents. For published data regarding holding strength, fastener torque, patents, and trademarks, visit the S-5! website at www.S-5.com. Copyright 2016, Metal Roof Innovations, Ltd. S-5! products are patent protected. S-5! aggressively protects its patents, trademarks, and copyrights.

S-5![®]

The Right Way!

The right way to attach almost anything to metal roofs!

Step 5: Splices

At the end of each section of pipe where it meets an adjoining section it will be necessary to install a pipe splice. Splices come inserted in the end of the 1" pipe supplied by S-5! distributors. As each section of pipe is laid down, use the splice to connect the pipes creating an unbroken run of pipe. Splices should be staggered so that the connections on the top pipes do not align with the connections on the bottom pipes. Trim the first top pipe of the assembly so that the splice falls between a different set of DualGard brackets than the bottom pipe splice.

NOTE: S-5! splices are designed with a dimple at center to provide relief for thermal expansion.

Step 6: Completing assembly and adding final components

Repeat steps 3, 4, & 5 until assembly is complete. As mentioned in step 3 the last pipe assembly should have collars placed just inside of the last bracket of the run. Once the last pipe & bracket assembly is in place, tighten the set screws on the two collars. Be sure to leave 1" of space between the collars and the bracket at both ends of the assembly to allow for thermal movement.

DualGard assemblies should not exceed 100' in length. If a longer run is necessary, finish the assembly at or before 100' and begin a new assembly.

At this point it may be necessary to trim the pipe so that it does not extend more than 6" past the final bracket in the run. This is best achieved using a reciprocating or circular saw with a fine-tooth carbide tip blade. Finish the run by installing the end caps.

Don't forget DualClips™!

The use of DualClips is recommended with the DualGard system

DualClip II™ and DualClip III™ are optional components that can be added to your S-5! DualGard™ snow retention system to further retard the migration of snow. DualClip II fits seams heights from 1" to 1.5". DualClip III fits seams 1-3/4" to 3-1/4".

When seam spacing is $\leq 24"$ one DualClip is used between each seam on the first row of snow retention (Fig. 8). When seam spacing is $>24"$, two clips should be used (Fig. 9).

Reference the DualClip installation instructions.

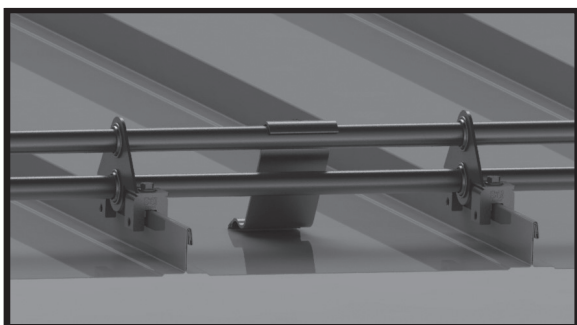

Fig. 8: One DualClip between seams spaced $\leq 24"$

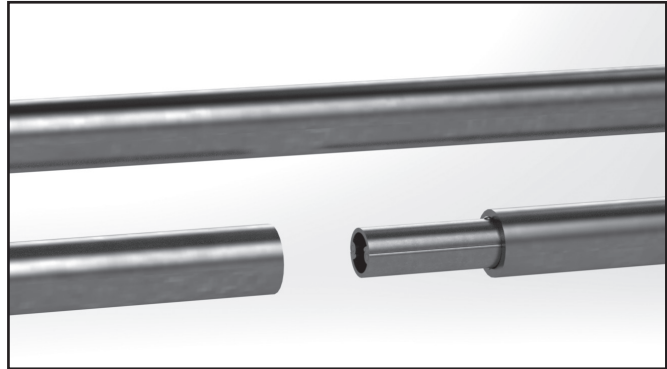

Fig. 6: Connecting 1" pipes with splices. Splices in top cross-member offset from splices in bottom

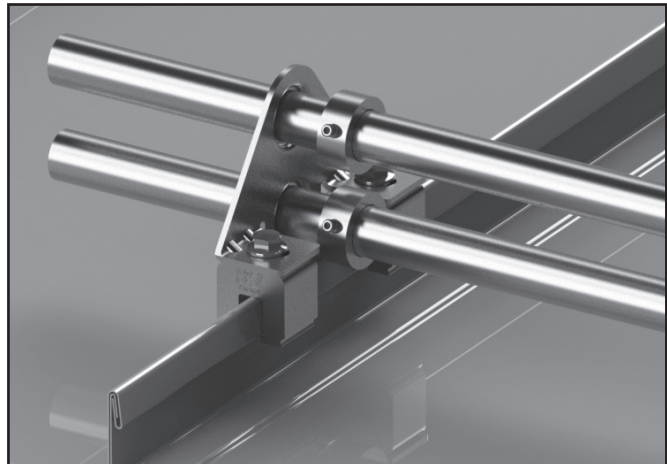

Fig. 7: DualCollars placed 1" inside of last pipe. Tighten set-screws in collars and trim pipe ends no more than 6" from end of last bracket.

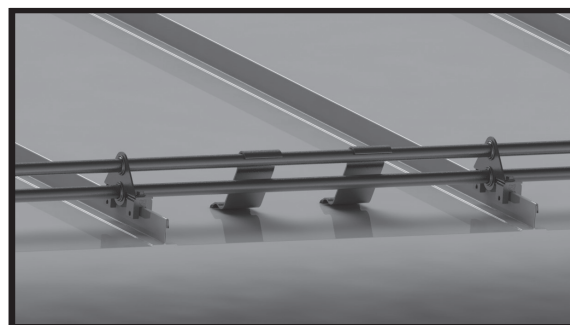
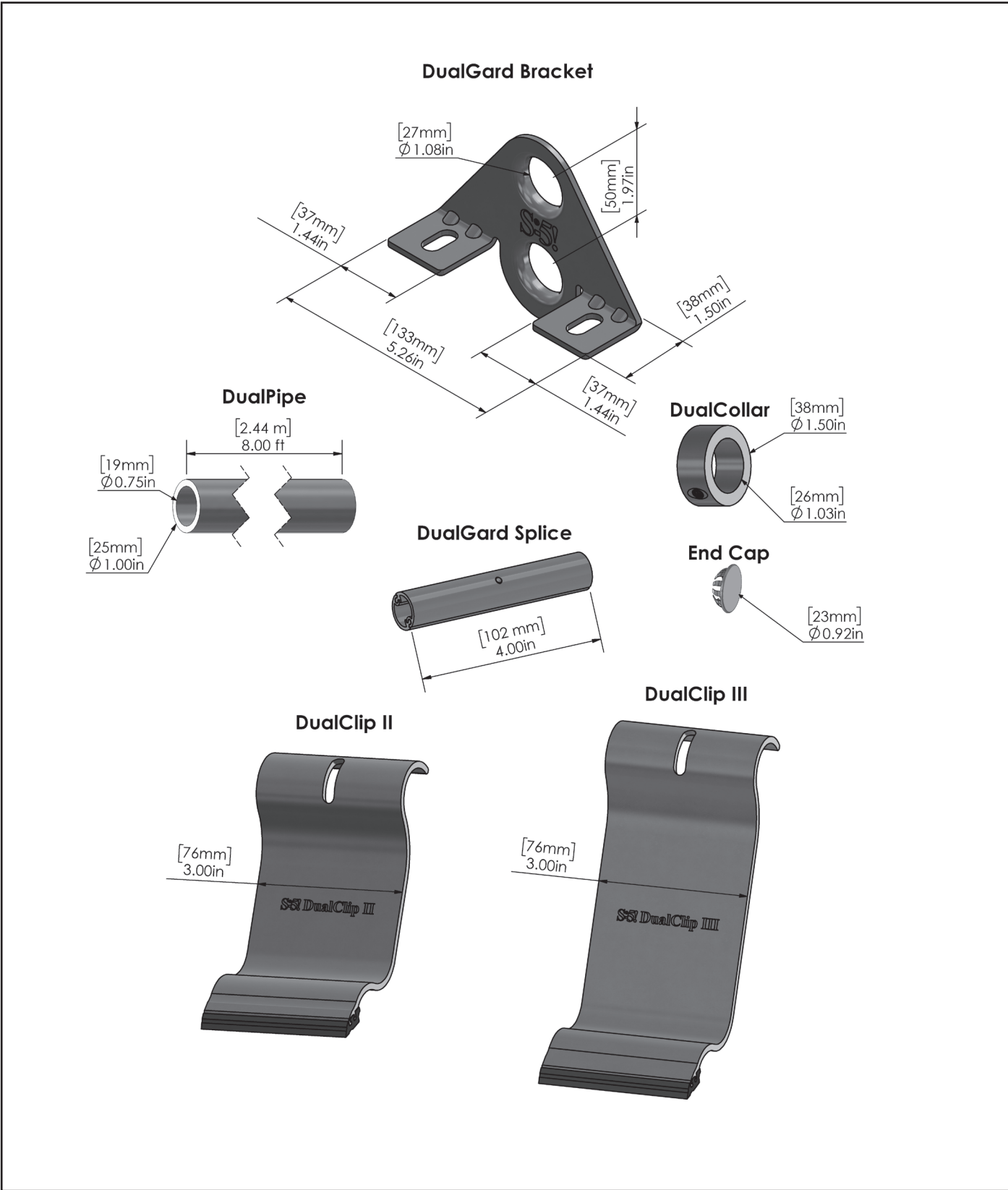

Fig. 9: Two DualClips between seams spaced $>24"$

These instructions are for use by those experienced in the trade. Always follow appropriate safety precautions and use appropriate tools.



S-5!® Warning! Please use this product responsibly!

Products are protected by multiple U.S. and foreign patents. For published data regarding holding strength, fastener torque, patents, and trademarks, visit the S-5! website at www.S-5.com. Copyright 2016, Metal Roof Innovations, Ltd. S-5! products are patent protected. S-5! aggressively protects its patents, trademarks, and copyrights.