

XCL-CG510 (B/W)
XCL-CG510C (Color)
XCL-CG160 (B/W)
XCL-CG160C (Color)



CL Output	Progressive Scan	^{*1} 2/3 Type GS CMOS	^{*2} 1/2.9 Type GS CMOS	Square Pixels	C Lens Mount	^{*1} 5.1 MP Output	^{*2} 1.6 MP Output
Area Gain	Image Flip	Long Exposure	Normal Shutter	External Trigger Shutter	Auto Shutter	Bulk Trigger	Sequential Trigger
Burst Trigger	Trigger range	Partial Scan	^{*2} Partial Scan Multi ROI	^{*4} Binning	^{*2} Decimation	Shading Correction	Temperature Readout
Defect Correction	^{*3} One-Push White Balance	^{*3} Manual White Balance	LUT	^{*4} B/W	^{*4} Near-IR Sensitivity		

^{*1} : XCL-CG510/XCL-CG510C ^{*2} : XCL-CG160/XCL-CG160C
^{*3} : XCL-CG510C/XCL-CG160C ^{*4} : XCL-CG510/XCL-CG160



Outline

With 5.07 million pixel high resolution and 35 fps high frame rate, the XCL-CG Series achieves a compact 29 (W) x 29 (H) x 30 (D) mm size. Easy replacement for the conventional CCD equipped model XCL-C Series.

Features

High frame rate
 You can select a frame rate of up to 35 fps based on the combination of output bit length and camera link tap settings.

XCL-CG510/510C
 Supports Base Configuration 3tap.

		Camera Link tap (Pixel clock frequency : 75 MHz)		
		1	2	3
Bit length	8	14 fps	28 fps	35 fps
	10	14 fps	28 fps	
	12	14 fps	28 fps	

XCL-CG160/160C
 Supports Base Configuration 3tap.

		Camera Link tap (Pixel clock frequency : 75 MHz)		
		1	2	3
Bit length	8	44 fps	90 fps	127 fps
	10	44 fps	90 fps	
	12	44 fps	90 fps	

Area Gain
 You can set the individual digital gain (0 to 32times) to 16 optional rectangular areas. In the case that multiple rectangular areas overlap, the gain value with the smaller area number will have priority. The image can be optimized to suit the subject (part), in applications such as part inspection.

When area gain is OFF

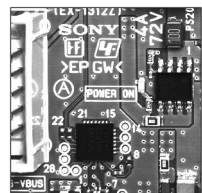

* Sample image

When area gain is ON

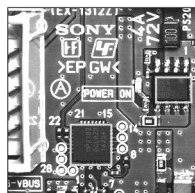

* Sample image

In case setting Gain=2 at Area 0 and Area 1

Image Flip

You can flip the image vertically or horizontally, or rotate it 180 degrees.

		ReverseX	
		0	1
ReverseY	0	Normal	Flip horizontally
	1	Flip vertically	Rotate 180 degrees

Shading Correction

Depending on the characteristic of the lens, shadings caused by a drop in the amount of light around the lens, or light source variation, are corrected.

The nine patterns can be saved as the user settings
 XCL-CG510/CG510C: 9 patterns
 XCL-CG160/CG160C: 31 patterns

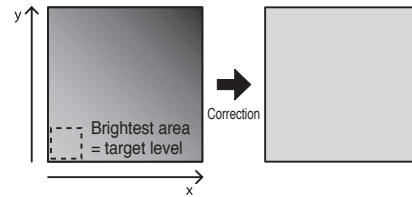

Defect Correction

This function is useful for applications that require high resolution. It corrects clear defect points and opaque defect points of the image sensor.

It can also correct any white or black flecks that may appear in the image due to factors such as cosmic rays. From the peripheral pixels, correction is performed on coordinate pixels in which defects are detected.

Factory setting and user setting can be selected.
 * Factory setting :ON

3 x 3 filter

Utilizing the 3 x 3 filter, you can obtain images in various processing conditions. Depending on the patterns of parameters, you can reduce noise, apply edge enhancement and extract the contour.

3 x 3 filter: OFF



Laplacian filter



Partial scan

The partial scan function outputs a user-defined region (Area Of Interest) within the overall image area. The cut-out region for partial scan is defined by Offset X and Offset Y (which indicate the start point for cutting), and Width and Height (which indicate the area). Contiguous blocks of minimum areas can be selected to define regions. However, the defined region must be a square or right rectangle. T- and L-shaped regions are invalid.

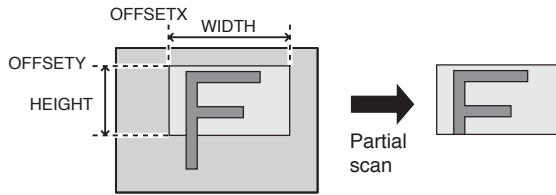

Note

Be aware that the frame rate increases for vertical cut-outs, while the frame rate remains unchanged for horizontal cut-outs.

Multi ROI (XCL-CG160/XCL-CG160C Only)

Arbitrarily read out images including any 2 (max.) rectangular area from the maximum effective imaging area.

Due to this, you will be capable of limiting read out information, thus accelerating the frame.

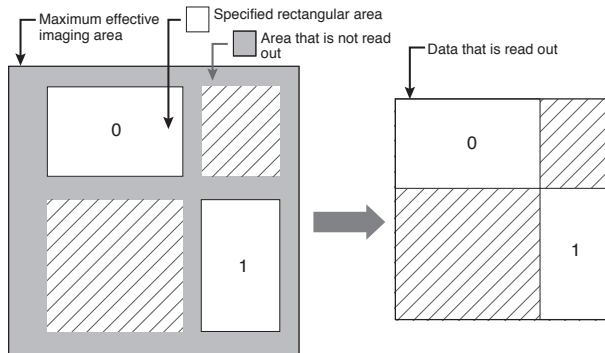

- Temperature Readout
- LUT (Look up Table)
- Trigger Range Limit
- Special Trigger modes
(Bulk trigger/Sequential trigger/Burst trigger)
- Camera Link (PoCL*)
*PoCL : Power over Camera Link
- Dimensions (29 (W) x 29 (H) x 30 (D) mm
(excluding protrusions)
- Mass : 53 g

Accessories

- Compact camera adaptor
DC-700/700CE
- Tripod adaptor
VCT-3331

Location and Function of Parts and Controls

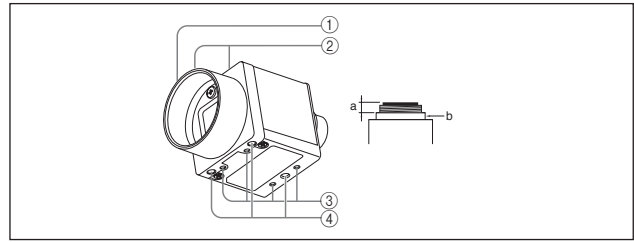

1 Lens mount (C-mount)

Attach any C-mount lens or other optical equipment.

Note

Use a C-mount lens with a protrusion (a) extending from the lens mount face (b) of 10mm or less.

2 Guide screw holes (Top)

3 Guide screw holes/Tripod screw holes (bottom)

When using a tripod, use these four screw holes to attach a VCT-3331 tripod adaptor.

4 Reference screw holes (Bottom)

These precision screw holes are for locking the camera module.

Locking the camera module into these holes secures the optical axis alignment.

Dimensions

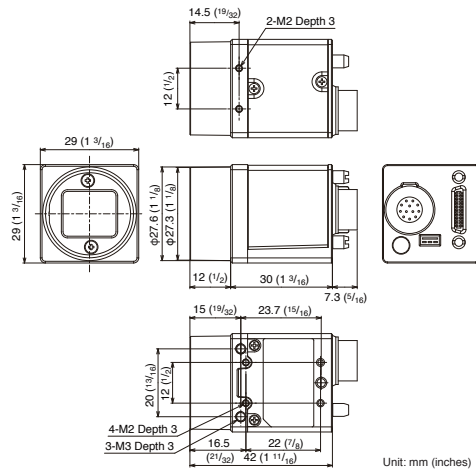

Connecting the Cables

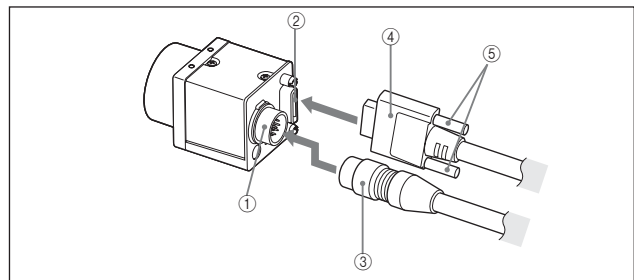

Connect the camera cable to the DC IN connector and the Camera Link cable to the DIGITAL IF cable respectively. If you use a camera module interface board with support for PoCL, you can operate the camera even if you do not connect the camera cable to the DC IN connector. When you connect the Camera Link cable, turn the two fastening screws on the connector to secure the cable tightly. Connect the other end of the camera cable to the DC-700/700CE and the other end of the Camera Link cable to the camera module interface board.

- ① DC IN Connector ② DIGITAL IF (Interface) Connector
- ③ Camera Cable ④ Camera Link Cable ⑤ Fastening Screws

Note

When using the camera with a PoCL connection, make sure you connect a PoCL compatible cable. Connecting a cable that is not compatible with PoCL (non-PoCL) may cause a malfunction of the camera or camera module interface board.

Rear Panel/Pin Assignments

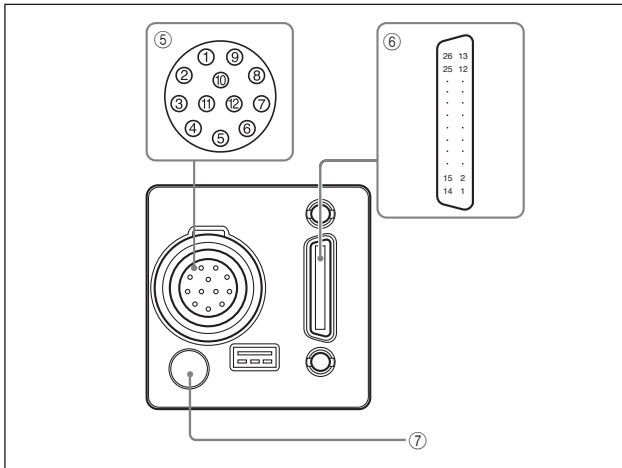

⑤ DC IN (DC power input) connector (12-pin) (Connector shape : SDR)

Pin No.	Signal	Pin No.	Signal
1	Ground	7	GPI3 ⁺²
2	DC12V	8	Ground
3	Ground	9	GPO3 ⁺¹
4	GPO1 ⁺¹	10	GPI2 ⁺²
5	Ground	11	GPI1 ⁺²
6	GPO2 ⁺¹	12	Ground

*1 Signal output from pin 4, 6, 9 (GPO1/2/3) of DC IN connector

This setting allows you to select from exposure signal, strobe control signal, Hi/Low fixed value, etc.
The initial values of GPO1/2/3 are all Hi fixed.

*2 Signal output from pin 7, 10, 11 (GPI3/2/1) of DC IN connector

Function as GPI input or trigger input. The initial setting is GPI1 for trigger input and GPI2/3 for GPI input.

⑥ DIGITAL IF (Interface) connector (26-pin miniconnector)

Camera Link Base Configuration:(Connector shape:SDR)

Pin No.	Signal	Pin No.	Signal
1	Power supply or Ground*	14	Ground
2	X0-	15	X0+
3	X1-	16	X1+
4	X2-	17	X2+
5	XCLK-	18	XCLK+
6	X3-	19	X3+
7	SerTC+	20	SerTC-
8	SerTFG-	21	SerTFG+
9	CC1-	22	CC1+
10	CC2+	23	CC2-
11	CC3-	24	CC3+
12	CC4+	25	CC4-
13	Ground	26	Power supply or Ground*

*About the 1st pin and 26th pin of the DIGITAL IF connector

The connection differs depending on the type of camera module interface board you use.

In the case of PoCL support:

Both the 1st pin and 26th pin are Power supply

In the case of non-PoCL support:

Both the 1st pin and 26th pin are Ground

⑦ Status LED (Green)

When power is supplied to the camera, this button is lit. Various settings are available, such as to light up when interlocking with the trigger signal.

Controlling the Camera From the Host Device

You can control the camera from host device such as a computer. The following table shows the major control functions.

Control functions	Description	
Operating mode	Free run/Trigger	
Shutter speed	Free run	1/100,000 s. to 60 s.
	Trigger edge detection	1/100,000 s. to 60 s.
	Trigger pulse width detection	Setting by trigger pulse width
Gain	0 dB to 18 dB	
Partial Scan	Variable, 4-line increments	
LUT (Look Up Table)	OFF/ON (Mode: 5 types)	
External trigger input	DIGITAL IF connector/DC IN connector	
Video output switch	Monochrome model: Mono 8/10/12-bit Color model: Raw 8/10/12-bit, RGB 24-bit	
Binning (Monochrome camera only)	2 × 1, 1 × 2, 2 × 2	
Defect correction	OFF/ON	
Shading correction	OFF/ON	

Trigger Signal Input

Trigger signals can be input via the 7th, 10th, 11th pins of the DC IN connector, the CC1, CC2, CC3, CC4 pins of the Digital IF connector, or the software command. Switchover of the trigger signal can be changed via the TRG-SRC command.

command	param	Trigger signal assigned pin
TRG-SRC	7	DC IN connector 7th pin (GPI3)
	10	DC IN connector 10th pin (GPI2)
	11	DC IN connector 11th pin (GPI1)
	101	Digital IF connector 22nd [+] / 9th [-] (CC1)
	102	Digital IF connector 10th [+] / 23rd [-] (CC2)
	103	Digital IF connector 24th [+] / 11th [-] (CC3)
	104	Digital IF connector 12th [+] / 25th [-] (CC4)
	0	Software command (TRG-SOFT)
	20	OR of GPI1/GPI2/GPI3

GPIO

GPI

The value can be checked by detecting the signals input to the DC IN connector 7th, 10th, and 11th using the GPI command. Since all pins are pulled up, 1 (Hi level) is returned if they are opened.

GPO

GPO1, GPO2 and GPO3 outputs can be transmitted from the DC IN connector 4th, 6th and 9th pins, respectively. After selecting a signal, the output polarity should be determined by GPO-INVERTER. The strobe control signal can be set separately for GPO1, GPO2 and GPO3.

Spectral Sensitivity Characteristics

B/W model

- XCL-CG510
- XCL-CG160

(Lens characteristics and light source characteristics excluded.)

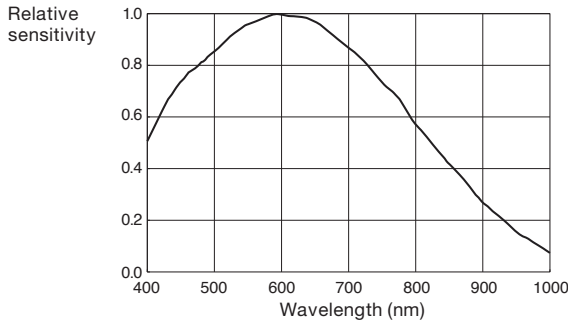

Color model

- XCL-CG510C
- XCL-CG160C

(Lens characteristics and light source characteristics excluded.)

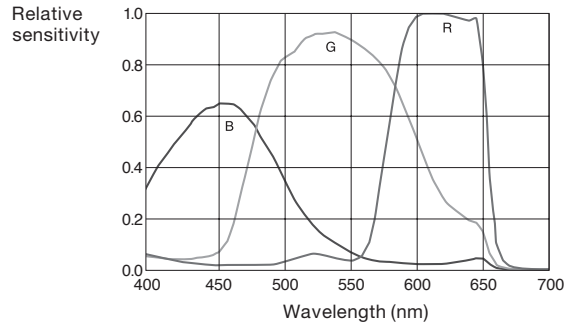

Specifications

	XCL-CG510	XCL-CG510C	XCL-CG160	XCL-CG160C
Basic specifications				
Image type	B/W	Color	B/W	Color
Image size	5.1 MP		1.6 MP	
Image sensor	IMX264 : 2/3-type Global Shutter CMOS Sensor (Pregius)		IMX273 : 1/2.9-type Global Shutter CMOS Sensor (Pregius)	
Number of effective pixels (H x V)	2,464 x 2,056		1,456 x 1,080	
Cell size (H x V)	3.45 μm x 3.45 μm			
Standard output pixels (H x V)	2,448 x 2,048		1,440 x 1,080	
Color filter	—	RGB color moxaic filter	—	RGB color moxaic filter
Frame rate	14 fps (Base 8 bit 1tap Mono/Raw) 28 fps (Base 8 bit 2tap Mono/Raw)* 35 fps (Base 8 bit 3tap Mono/Raw) * default setting		44 fps (Base 8bit 1tap) 90 fps (Base 8bit 2tap) 127 fps (Base 8bit 3tap) * default setting	
Minimum illumination	0.5 lx (Iris: F1.4, Gain: +18 dB, Shutter: 1/30 s)	12 lx (Iris: F1.4, Gain: +18 dB, Shutter: 1/30 s)	0.5 lx (Iris: F1.4, Gain: +18 dB, Shutter: 1/30 s)	12 lx (Iris: F1.4, Gain: +18 dB, Shutter: 1/30 s)
Sensitivity	F5.6 (400 lx, Gain: 0 dB, Shutter: 1/30 s)	F5.6 (2000 lx, Gain: 0 dB, Shutter: 1/30 s)	F5.6 (400 lx, Gain: 0 dB, Shutter: 1/30 s)	F5.6 (2000 lx, Gain: 0 dB, Shutter: 1/30 s)
SNR	More than 50 dB (Lens close, Gain: 0 dB, 8 bits)			
Gain	Auto, Manual : 0 to 18 dB			
Shutter speed	Auto, Manual : 60 to 1/100,000 s			
White balance	—	Manual, One push	—	Manual, One push
Camera Features				
Readout modes	Normal, Binning (2x1, 1x2, 2x2)*1, Partial scan	Normal, Partial scan	Normal, Binning (1x2, 2x1, 2x2), Decimation, Partial scan (Multi ROI)	Normal, Decimation, Partial scan (Multi ROI)
Readout features	LUT (Binarization, Gamma (arbitrary setting), Test pattern)			
Synchronization	Hardware trigger, Software trigger			
Trigger modes	OFF (Free run), ON (Trigger edge detection, Trigger width detection), Special trigger (Burst trigger, Bulktrigger*, Sequentialtrigger*) * Except XCL-CG160/CG160C			
User Set/Memory channel	16			
User memory	32 kbytes + 64 bytes x 16 ch			
Partial scan	W (Pixel)	16 to 2464	16 to 1,456	
	H (Line)	4 to 2,056	8 to 1,088	
GPO	EXPOSURE/Strobe/LVAL/FVAL/Sensor lead out/Trigger through/Pulse generation signal/User defined 1, 2, 3 (Output switching)			
Other features	Area gain, Defect correction, Shading correction, Temperature readout, LUT, 3 x 3 filter			
Interface				
Video data output	digital Mono 8, 10, 12 bit (default setting 8 bits)	digital Raw 8, 10, 12 bit (default setting Raw 8 bit) digital RGB 24 bit	digital Mono 8, 10, 12 bit (default setting 8 bits)	digital Raw 8, 10, 12 bit (default setting Raw 8 bit) digital RGB 24 bit
Base Clock	45/75 MHz switchable			
Camera Link Tap	1/2/3 switchable			
Digital interface	LVDS			
Camera specification	Camera Link® Version2.0 (Connector shape : SDR)			
Output data clock	45MHz (1,2,3tap) 75MHz (1,2,3tap)			
Digital I/O	TTL IN (x3), TTL OUT (x3)			
General				
Lens mount	C-mount			
Flange focal length	17.526 mm			
Power requirements	DC +12V (10.5 V to 15.0 V), PoCL (10 V to 13.0 V)			
Power consumption	2.7 W max. (DC +12V)			
Operating temperature	-5°C to +45°C (23 °F to 113 °F)			
Performance guarantee temperature	0°C to 40°C (32°F to 104°F)			
Storage temperature	-30°C to +60°C (-22°F to +140°F)			
Operating humidity	20% to 80% (no condensation)			
Storage humidity	20% to 80% (no condensation)			
Vibration resistance	10 G (20 Hz to 200 Hz, 20 minutes for each direction-x, y, z)			
Shock resistance	70 G			
Dimensions (W x H x D)	29 x 29 x 30 mm (1 3/16 x 1 3/16 x 1 3/16 inches) (excluding protrusions)			
Mass	Approx. 53 g (1.9 oz)			
MTBF	81,562 hours (Approx. 9.3 years)		76,315 hours (Approx. 8.7 years)	
Regulations	UL60950-1, FCC Class A, CSA C22.2-No.60950-1, IC Class A Digital Device, CE : EN61326 (Class A), AS EMC: EN61326-1, VCCI Class A, KCC, CU-TR EAC			
Supplied accessories	Lens mount cap (1), Safety Rglations *2 (1)			

*1 The frame rate does not change.

*2 It describes the safety precaution. Those contents which had described in Operation Manual are aggregated in the Technical Manual.