



QN HD Camera Control Unit Instruction & Admin Manual





InterTest, Inc. • 303 Route 94 • Columbia, NJ 07832

Table of Contents

Table of Figures..... 5

Figure 1 CCU Front 13 5

Figure 2 CCU Front 13 5

Figure 3 CCU Back 13 5

Figure 4 Labeled Front of CCU 14 5

Figure 5 Labeled Back of CCU 14 5

Figure 6 External Chassis Ground Connection 15..... 5

Figure 7 Camera CCU Menu Tree 16 5

Figure 8 Non-LED Version CCU & Camera Dimensions 35 5

Figure 9 LED Version CCU Dimensions 36..... 5

Figure 10 LED Version CCU Pin Out 36..... 5

Figure 11 CCU Circuit Brd Layout 48..... 5

Figure 12 Connector Pin Out 49 5

Contact Information 6

Cautions and warnings. 6

 Safety Precautions..... 6

 Operational, General Safety Considerations and Precautions 6

 Cautionary Symbols and Symbol Terminology 7

 Warnings..... 7

 Disclaimers 7

Warranty..... 8

Copyrights and Rights of Portrait 9

Registered Trademark Information 9

System Components 10

Controls and connections 11

Connections 12

 Standard Connections..... 13

General Operation..... 13

Camera Control Unit Menu Structure 14

 Menu Tree 14

 Image Quality..... 15



More Image Quality	15
ISP Control (Sensor).....	15
ISP Control 2	16
Capture Setup (Not Used in Pole Cam)	16
Utility Menu	17
System Diagnostic	18
Save Setup	18
Load Presets (Not used in Pole Cam)	19
Lens Correction.....	19
Pan Tilt Zoom Menu	19
Set to defaults	20
microSD card	21
Saving images	21
Using With A PC	21
Connection Steps	21
QNHD Serial Commands:	22
Software Disclaimer.....	22
Communication Specifications:	23
Communication Pin-Out	23
Command Structure:.....	24
Command/Inquiry:	24
Responses:.....	24
QNHD Command List.....	25
Inquiries:	29
Shutter Table:	31
Specifications	32



Camera Head	32
Camera Cable.....	32
Camera Control Unit (CCU).....	32
LED Output (CCU)	33
Controller & Camera Mechanical Specifications (Non-LED Version).....	33
Controller & Camera Mechanical Specifications (LED Version)	34
Control Menu Values & Defaults.....	35
Care & Maintenance	37
Overall System.....	37
Trouble Shooting	37
Returns for Repair or Service	37
Return Evaluation Procedure	37
Parts and Accessories	39
Admin Section.....	40
Dip Switch Settings	40
Main Menu	40
Image Menu	41
More Image Quality	41
Capture Menu	41
Utility Menu	42
Save Preset	42
Load Preset.....	43
Diagnostics	43
PTZ Menu.....	44
Reset to Defaults	44
Lens Correction.....	45



Circuit Board Layout / Connections	46
SCB300B Firmware Upload Procedure	47
SCB300B AEQ Procedure.....	48
NOTES:.....	49

Table of Figures

Figure 1 CCU Front	11
Figure 2 CCU Front	11
Figure 3 CCU Back	11
Figure 4 Labeled Front of CCU	12
Figure 5 Labeled Back of CCU	12
Figure 6 External Chassis Ground Connection.....	13
Figure 7 Camera CCU Menu Tree	14
Figure 8 Non-LED Version CCU & Camera Dimensions.....	33
Figure 9 LED Version CCU Dimensions	34
Figure 10 LED Version CCU Pin Out.....	34
Figure 11 CCU Circuit Brd Layout	46
Figure 12 Connector Pin Out	47

Contact Information

To contact us, please refer to the information below:

Corporate Headquarters

InterTest, Inc.

303 Route 94

Columbia, NJ 07832 USA

Telephone (USA and Canada): 800-535-3626

Telephone (Outside the USA and Canada): 908-496-8008

Facsimile: 908-496-8004

Visit us on the Internet

www.intertest.com

General Information via Email

Email: info@intertest.com

InterTest © 2020 All rights reserved

Cautions and warnings.

Safety Precautions

This manual covers the QN HD equipment, its functions, and use. It also covers precautions to be taken to ensure safe operation. Please read this manual thoroughly before operating the equipment. By doing so, you will become familiar with the equipment's capabilities and better understand its functions. After reading this manual, save it for future reference.

Follow all warnings and instructions in the manual and marked on the equipment.

Operational, General Safety Considerations and Precautions

Always observe the guidelines and precautions that follow.

There are no user-serviceable parts inside the controller. Refer all service to the InterTest Customer Service and Support Group.







IMPORTANT: To ensure operator safety, read and understand this manual before using the system.

To avoid injury, read and understand the associated documentation of support components prior to operation. Direct any questions about equipment operation to InterTest Customer Service and Support Group at 908-496-8008 or via email to service@intertest.com.

Cautionary Symbols and Symbol Terminology

Table A describes the various symbols that may be included in this manual and mounted on the equipment. The severity level of a potential hazard varies. Refer to for hazard level descriptions.

Table A — Manual and Equipment Safety Symbols

Symbols	Definitions
	WARNING/CAUTION: Risk of electric shock.
	WARNING/CAUTION: Refer to instruction manual.
	WARNING/CAUTION: Avoid exposure to water and liquids.
	WARNING/CAUTION: Avoid eye and skin exposure to UVA Light.

Warnings

Stop operation immediately when any abnormality or defect occurs. Use during an abnormal condition; such as emitting smoke, burning odors, after damage from dropping, invasion of foreign objects, etc. may cause fire and/or electrical shock. Disconnect the power plug from the electrical outlet at once and contact InterTest Inc.

Only use the specified power supply.

Do not connect or disconnect any cable while the unit is energized.

Some surfaces may be warm to the touch. Use caution when handling.

Disclaimers

We disclaim any responsibility and shall be held harmless for any damages or losses uncured by the user in any of the following cause:



1. Fire, earthquake or any other Act of God. Acts by third parties; misuse by the user, whether intentional or accidental; use under conditions outside of noted operating range.
2. Malfunction or non-function resulting in indirect, additional or consequential damage including but not limited to loss of expected income and suspension of business activities.
3. Use not in compliance with this manual's instructions.
4. Malfunctions resulting from misconnection.
5. Unauthorized repairs or modifications.
6. Notwithstanding the foregoing, InterTest's liabilities shall not, in any circumstances, exceed the purchase price of the product.

Warranty

Warranty Statement

InterTest, Inc. guarantees products manufactured by InterTest, Inc. to be free from defects in materials and workmanship for a period of one (1) year, from the date of original purchase. All other products not manufactured by InterTest, Inc. will carry the OEM's limited warranty, which will be passed to the purchaser through and supported by InterTest, Inc. InterTest, Inc.'s obligation under this limited warranty shall be confined to the repair or exchange of any part, or parts thereof, that prove defective under normal use and service for which the product was intended or designed.

This limited warranty covers products that upon our examination are deemed to be defective.

This limited warranty is in lieu of all other warranties, express or implied, including the warranties of merchantability and fitness for use. We neither assume, nor authorize any other person to assume for us, any other liabilities in connection with the sale of InterTest, Inc. equipment. This warranty does not apply to any equipment that has been subject to accident, negligence, alteration, abuse, unauthorized repair, improper storage, or other misuse.

This limited warranty applies only to the original purchaser and cannot be assigned or transferred to any third party without express written consent from InterTest, Inc.

This limited warranty does not apply to consumable items, expendable items or normal wear and tear, nor does it apply to failure due to radiation, overheating and / or below freezing temperatures.

InterTest, Inc. assumes no responsibility, either expressed or implied, regarding the improper usage of this equipment or interpretation of test data derived from the use of this equipment. InterTest, Inc.'s



responsibility and obligations, in all cases, are limited strictly to the repair and/or replacement costs outlined above.

The laws of the State of New Jersey shall govern this warranty.

Note: In the event the equipment cannot be returned to InterTest, Inc. The customer agrees to pay all travel and living expenses incurred to have an InterTest, Inc. representative evaluate, assess or affect a warranty repair in the field.

Copyrights and Rights of Portrait

There may be a conflict with the Copyright Law and other laws when a customer uses, displays, distributes or exhibits an image picked up by a television camera without permission from the copyright holder. Please also note that transfer of an image or file covered by copyright is restricted to use with the scope permitted by the Copyright Law.

Registered Trademark Information

InterTest™	is a registered trademark of InterTest, Inc.
iShot™	is a registered trademark of InterTest, Inc.
iShot™ Imaging™	is a trademark of InterTest, Inc.



IMPORTANT: If you are in possession of a printed or electronic version of this document, be aware that it may not be the current revision. To ensure that you are using the most up-to-date revision of this document, contact the InterTest Customer Service and Support Group or reference the downloads portal under this product on www.intertest.com.

System Components

1. CCU Camera Control Unit, manages and captures images from camera and outputs to display.
2. Camera CMOS sensor that capture HD resolution images.
3. Lens Camera attachment that provides focus and imaging optics.
4. Power Supply USB 3c cable and AC to DC powers CCU.
5. DVI Cable Cable that carries display images to external monitor when in use.
6. MicroSD Removable storage for captured images.
7. RS 232 cable Cable connecting to the RS 232 comm port
8. LED PS Auxiliary internal power supply for illumination LEDs

Controls and connections



LED 1	Green if camera head is connected and comm channel is locked, Yellow if not
LED 2	Power

Figure 1 CCU Front



Figure 3 CCU Back

Connections



Figure 4 Labeled Front of CCU

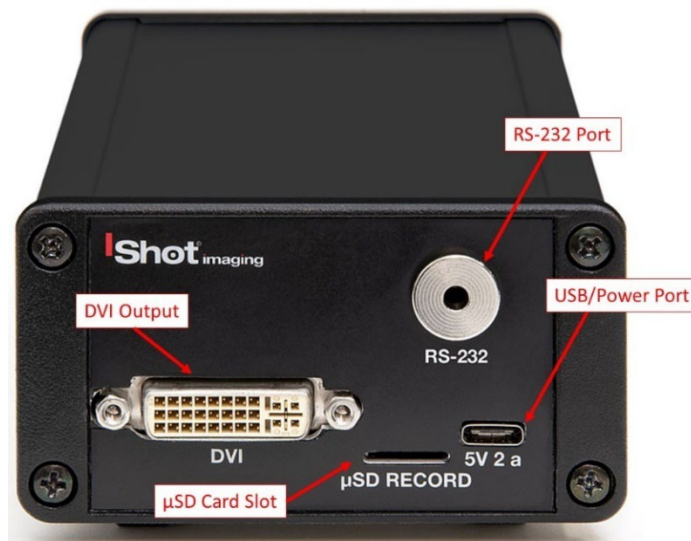

Figure 5 Labeled Back of CCU

Standard Connections

DVI	video output
USB-C	power input and USB video output
MicroSD	image storage
External COM Port	RS232 Communication from / to the CCU (EM69477)
Chassis Ground Connection	#8-32 x 3/8" Long Grounding Connection (See Fig # 5) Used to ensure CCU is at the same ground potential to avoid unforeseen ground loops

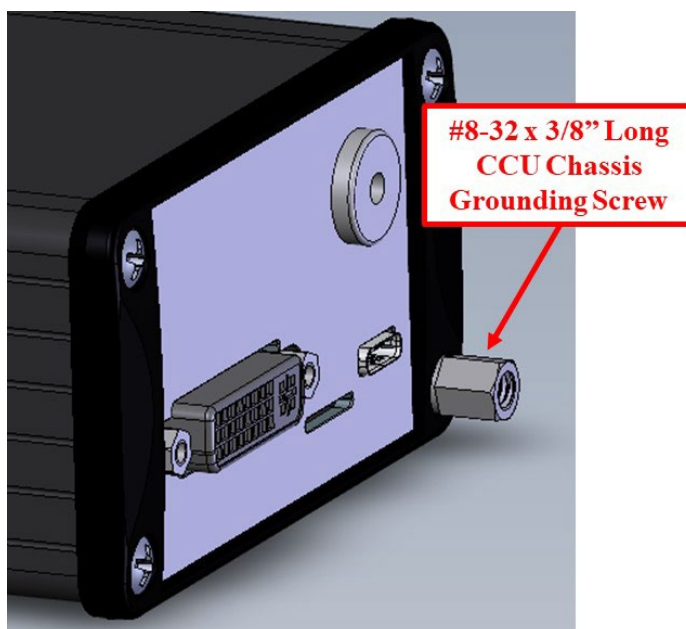

Figure 6 External Chassis Ground Connection

General Operation

After power is applied, Right indicator LED will light up, wait 5 seconds, until the Main Menu appears in the CCU Screen.

DVI is disabled when USB is connected. The Image is transmitted through USB to the PC, not the DVI port.

MicroSD card is used to save images. High speed card required.

If faster response time is needed operate in 720p with Zoom On (crop mode) rather than Off (scale mode). Scale mode still reads the whole sensor array thus running as if in 1080p.

Settings changes will be saved automatically on power down. If any parameter is changed a back step in menu is required for it to be saved on power down.

Camera Control Unit Menu Structure

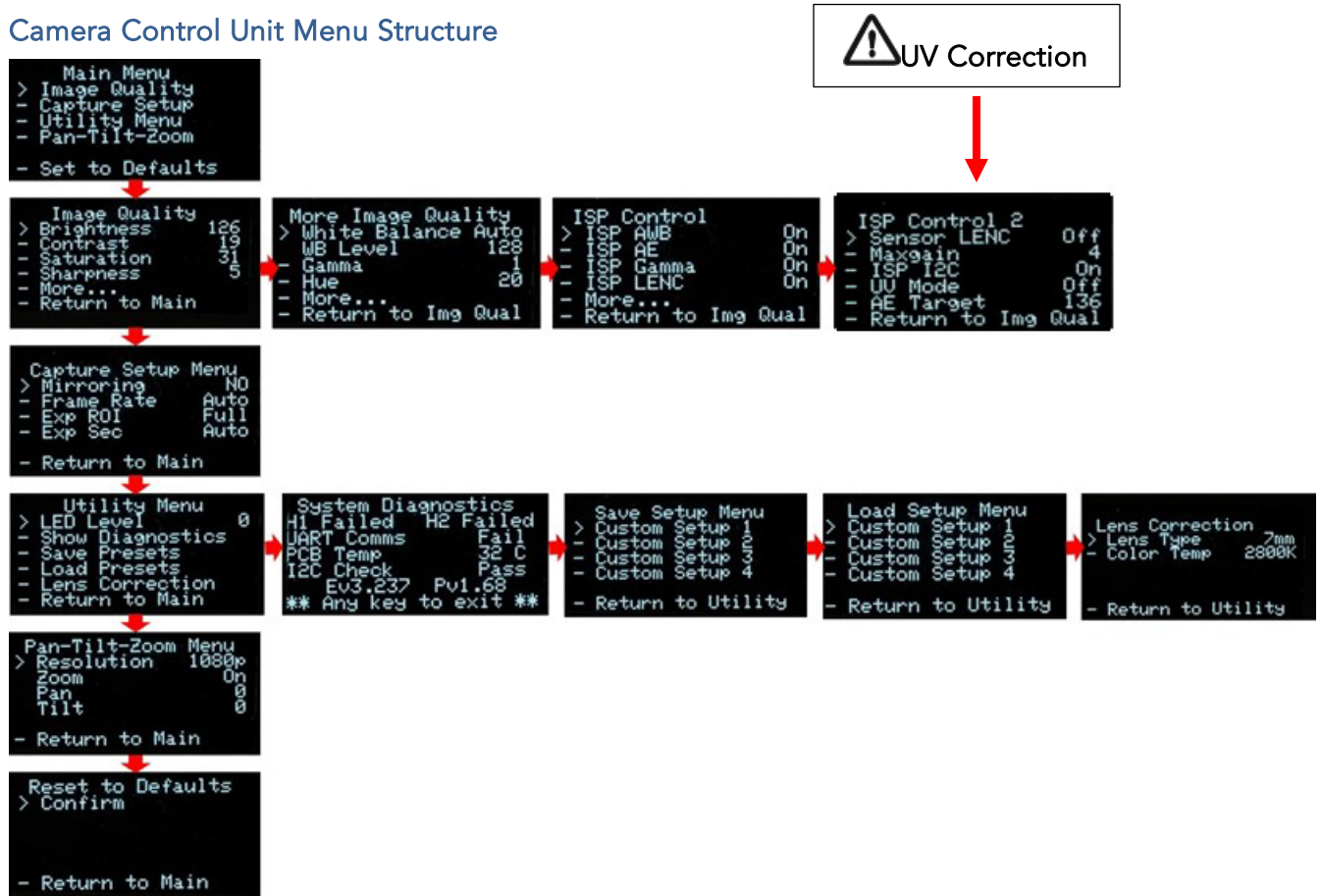

Figure 7 Camera CCU Menu Tree

Note:



Changes to camera settings can only be saved to Setup 1. Camera Setup 2-4 are set at the factory



Be sure to "Turn Off" UV Correction when doing White Light Inspection. See Figure 7

Menu Tree



Menu tree home.

Image Quality

```
Image Quality
> Brightness      126
- Contrast        19
- Saturation      31
- Sharpness       5
- More...
- Return to Main
```

Brightness: 0 to 255, Default: 128

Contrast: 0 to 63, Default: 19

Saturation: 0 to 63, Default: 31

Sharpness: 0 to 31, Default: 5

More continues to options on More Image Quality page.

Return to Main: returns to top of menu tree and saves settings.

More Image Quality

```
More Image Quality
> White Balance Auto
  WB Level      128
- Gamma         1
- Hue           20
- More...
- Return to Img Qual
```

White Balance: Auto or Set Set mode allows user to select fixed value.

WB Level: 0 to 255 Default: Auto

(50 appears to be about neutral in fluorescent lighting.)

Gamma: 0, 1, or 2 Default: 1

Hue: -180 to 180 Default: 0

Return to Img Qual: returns to previous page, Image Quality.

ISP Control (Sensor)

```
ISP Control
> ISP AWB      On
- ISP AE       On
- ISP Gamma    On
- ISP LENC     On
- More...
- Return to Img Qual
```

ISP AWB Auto White Balance Default: ON
 ISP AE Auto Exposure Default: On
 ISP Gamma Default: ON
 ISP LENC Default: ON. Note turning off will disable Lens Correction. **See Lens Correction**
 Note it is not recommended to have both SENSOR LENC and ISP LENC "ON"

ISP Control 2



Sensor LENC Default: OFF. Note it is not recommended to have both SENSOR LENC and ISP LENC "ON"

ISP I2C comm's to the sensor. Default: ON
 UV Mode Used when doing UV inspections. This should be turned off when doing white inspections
 AE Target Default 136

Capture Setup (Not Used in Pole Cam)



Mirror: No, H, V, HV. Default: No
 Frame Rate: Auto, 1 to 60 Hz in 1080 Default: Auto
 1 to 90 Hz in 720
 1 to 120 Hz in VGA
 Exp ROI: Full, Middle, Center Exposure Region of Interest. Area analyzed to adjust Image
 Exp ROI: Full, Middle, Center Exposure Region of Interest. Area analyzed to adjust Image

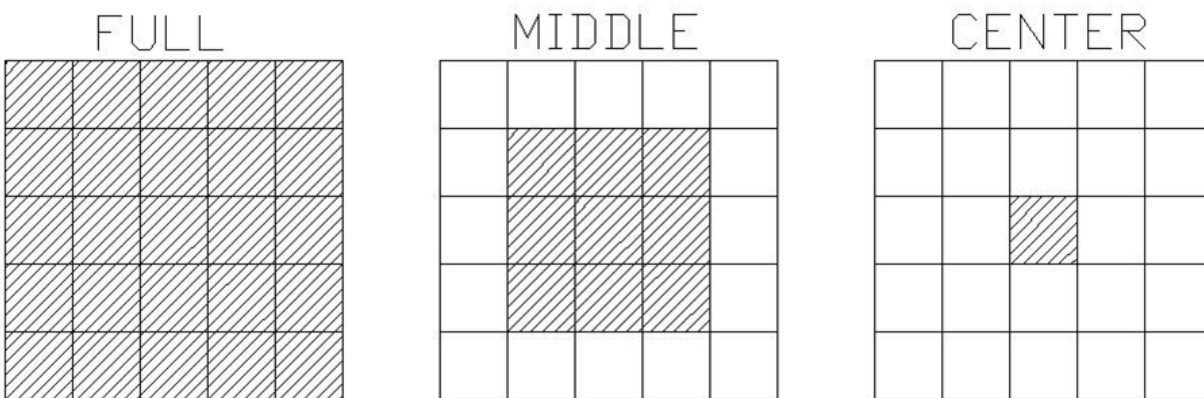

EXP Sec: Auto, 1, 1/2, 1/3, 1/4, 1/5, 1/6, Default: Auto
 Length of time image is exposed per second
 1/7, 1/8, 1/9, 1/10, 1/15
 1/20, 1/25, 1/30, 1/50,
 1/60, 1/100, 1/120, 1/250
 1/500, 1/1000, 1/5000,
 1/10000, 1/20000, 1/30000

Utility Menu



LED: 0 to 10 Light intensity level Constant Current @ 8VDC
 (See Aux Light QNHD Command List for RS232)
 Not used in Pole Cam

Show Diagnostics Displays system diagnostics Status

Save Presets Allows current settings to be stored for later recall
 Do not use in Pole Cam.

Load presets Allows previously stored settings to be restored

Lens Correction For setting color correction of the lens installed

System Diagnostic

```
System Diagnostics
H1 Failed      H2 Failed
UART Comms    Fail
PCB Temp      32 C
I2C Check     Pass
Ev3.237 Pv1.68
** Any key to exit **
```

1080/30 (H1): Locked/Failed Camera type attached

1080/60 (H2): Locked/Failed Camera type attached (Not used in Pole Cam)

Note: Only one camera type will read as "Locked". The other will indicate fail

UART Comms:Pass/Fail USB communication functioning

PCB Temp: xx-xx C typ

(Temp on PCB)

I2C Error: 00xx

Ev#.### Pv#.## firmware revision loaded in CCU.

Save Setup

```
Save Setup Menu
> Custom Setup 1
- Custom Setup 2
- Custom Setup 3
- Custom Setup 4
- Return to Utility
```

Allows up to 4 sets of camera settings to be stored for later recall and use.

Note:

-Presets 2-4 are locked out in Pole Cam.

-Preset 1 can be modified & accessed by using the "Aux" setting on the Optical Adapter Switch. See Error! Reference source not found..

Load Presets (Not used in Pole Cam)

```

Load Setup Menu
> Custom Setup 1
- Custom Setup 2
- Custom Setup 3
- Custom Setup 4
- Return to Utility
    
```

Allows recall and use of any of 4 previously store sets of camera settings.

Lens Correction

```

Lens Correction
> Lens Type      7mm
- Color Temp    2800K
- Return to Utility
    
```

Allows setting lens installed and color temp for image correction.

LENS TYPE: A, B, C, D, E

Color Temp: 2800K, 4500K or 6500K

Pan Tilt Zoom Menu

```

Pan-Tilt-Zoom Menu
> Resolution    1080p
  Zoom          On
  Pan           000
  Tilt         000
- Return to Main
    
```

Resolution:	USB output	1080p, 720p, 480	Default: 1080p
	DVI output	1080p, 720p	
	In 1080p	Pan, Tilt & Zoom Disabled	
Zoom: (On/Off)	Default: Disabled	Note: Values in pixels	
Pan:	+/- 320 in 720p	Default: Disabled	
	+/- 640 in 480		
Tilt:	+/-180 in 720p	Default: Disabled	
	+/- 300 in 480		

Set to defaults

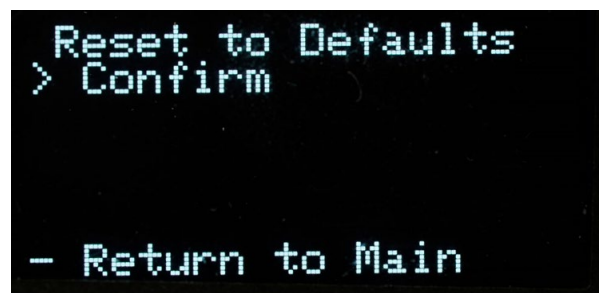

Confirm: changes settings to the factory default settings and returns to Main Menu.

Return to Main: Returns to top of Menu Tree (Main Menu), without changing settings.

microSD card

Must be CLASS 10 (10MB/s) or better (UHS-1, 2, or 3)

Saving images

With a microSD card installed, images can be captured by pressing the camera button on the front of the CCU. A slight dip in the intensity of the displayed image indicates the image has been saved.

Using With A PC

When the CCU is attached to a PC via a USB cable, the DVI display output connector is disabled and the image is displayed on the PC.

Connection Steps

- 1) Connect the camera.
- 2) Connect the USB Cable to the CCU & a USB 3.0 Port (Recommended)
- 3) The computer should recognize the camera as a UVC Device

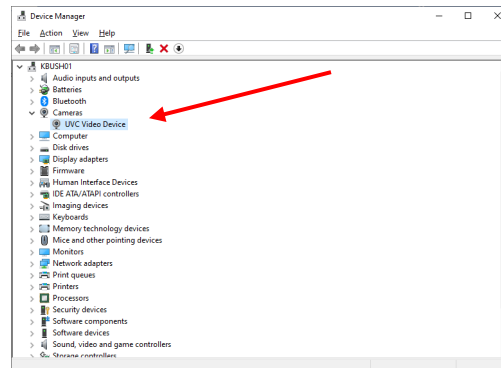

- 4) InterTest DocuView** or MS Windows Camera Applications can be used.
 - a. Resolution, frame rate, brightness & contrast can be adjusted in the Windows app.
 - b. Video recording & Image Snapshots are done with the computer

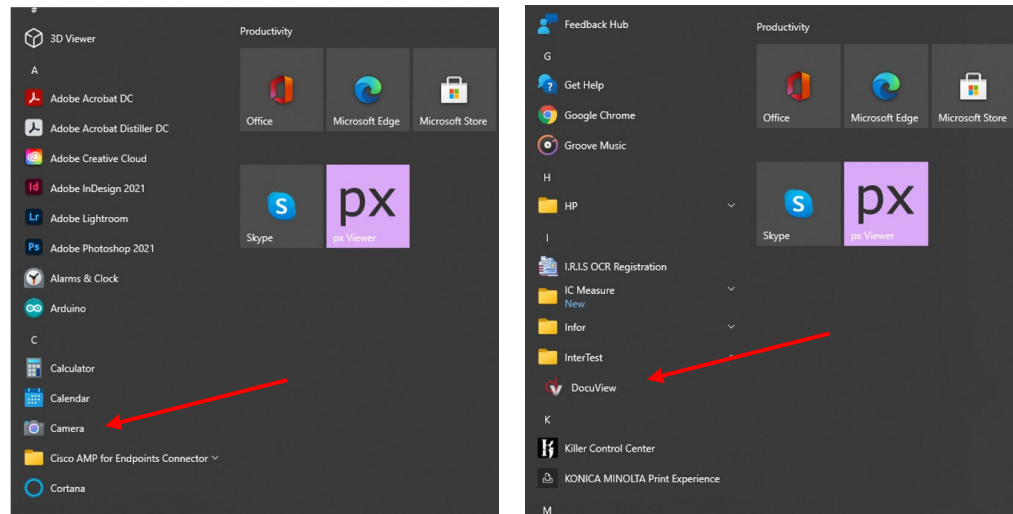

- c. Shutter and all other camera related functions are controlled through the QNHD CCU

QNHD Serial Commands:

Overview of communication:

RS232 Standard

9600 Baud Rate

8 byte packet size

Non parity

Software Disclaimer

SOFTWARE IS PROVIDED BY THE AUTHOR AND CONTRIBUTOR(S) "AS IS" AND ANY EXPRESS OR IMPLIED WARRANTIES, INCLUDING, BUT NOT LIMITED TO, THE IMPLIED WARRANTIES OF MERCHANTABILITY AND FITNESS FOR A PARTICULAR PURPOSE ARE DISCLAIMED. IN NO EVENT SHALL THE AUTHOR OR CONTRIBUTOR(S) BE LIABLE FOR ANY DIRECT, INDIRECT, INCIDENTAL, SPECIAL, EXEMPLARY, OR CONSEQUENTIAL DAMAGES (INCLUDING, BUT NOT LIMITED TO, PROCUREMENT OF SUBSTITUTE GOODS OR SERVICES; LOSS OF USE, DATA, OR PROFITS; OR



BUSINESS INTERRUPTION) HOWEVER CAUSED AND ON ANY THEORY OF LIABILITY, WHETHER IN CONTRACT, STRICT LIABILITY, OR TORT (INCLUDING NEGLIGENCE OR OTHERWISE) ARISING IN ANY WAY OUT OF THE USE OF THIS SOFTWARE, EVEN IF ADVISED OF THE POSSIBILITY OF SUCH DAMAGE*

Communication Specifications:

Each command or inquiry packet is made up of 8 bytes. The first byte will contain the target address followed by command or inquiry action byte, command byte, command modifier byte, three data bytes, followed by the end byte. The address will be either 0x42 for functions handled by the camera, or 0x43 for commands handled by the CCU. The action byte will be either 0x01 for a command or 0x09 for an inquiry. The command byte will specify which parameter or action is to be modified, taken, or inquired about. The command modifier byte determines what changes are made to the parameter specified in the command byte as defined below. The data bytes contain the values for the parameters to be set at during a direct command. The end byte is always 0xff to signify the end of a packet.

Communication Pin-Out

3.5mm TRS Plug

Tip: TX

Ring: Rx

Sleeve: GRND



Command Structure:

	Address	Action	Command	Command Modifier	Data	Data	Data	End
Byte	1	2	3	4	5	6	7	8
	0x42 (Camera)	0x01 (command)	0xpp (range 00-FF)	0x0p	0x00	0x00	0x0q	0xFF
	0x43 (Control Unit)	0x09 (Inquiry)		0xpp		0x00	0xqr	
						0xqr	0xst	

Byte 4 is the Command Modifier and is defined thus:

00 = Off/auto (only valid for some commands)

01 = Direct

02 = Increment

03 = Decrement

04 = Reset

Other = defined differently for each specific command

Command/Inquiry:

Command packets send action items to the camera

Inquiry packets are used to ask for the current state of the CCU or camera.

Responses:

Command execution information will be stored in byte 2 of the response packet, and will be as follows:

50 = command executed

60 = command could not be executed

61 = no camera head detected



All other bytes of response will be an echo of the code received by the CCU. Improper inquiries will return a value of 60 in the 2nd byte, and other bytes of the response packet will be an echo of the data sent.

A response to an inquiry will have the requested data stored in the three data bytes of the response packet. All other bytes will be an echo of the inquiry packet that was sent.

The CCU will wait for the response packet to be sent before accepting any new commands.

QNHD Command List

Command		Command HEX	Definition
AUX_Light	Off	43 01 01 00 00 00 00 FF	Off
	Direct	43 01 01 01 00 00 qr FF	on, % of max,(qr = 0x00 to 0x63)
	Up	43 01 01 02 00 00 00 FF	Light Increase 10%
	Down	43 01 01 03 00 00 00 FF	Light Decrease 10%
Image_Capture	Save	43 01 02 00 00 00 00 FF	Save image to SD
Custom_Setup	Save	43 01 03 01 00 00 0q FF	Save 1-4 (q = 1 to 4)
	Load	43 01 03 02 00 00 0q FF	Load 1-4 (q = 1 to 4)
Mirror	Direct	42 01 04 01 00 00 0q FF	q: 0-3 0 = No mirroring 1 = Horizontal mirror 2 = Vertical mirror 3 = Horizontal and vertical mirror
Frame_Rate	Auto	42 01 0A 00 00 00 00 FF	Auto
	Direct	42 01 0A 01 00 00 qr FF	1 - 30 qr: 01 to 1E 1080p
		42 01 0A 01 00 00 qr FF	1 -60 qr: 01 to 3C 720p
		42 01 0A 01 00 00 qr FF	1 - 120 qr: 01 to 78 640x480
EXP_ROI	Direct	42 01 11 01 00 00 00 FF	Full
		42 01 11 01 00 00 01 FF	Middle
		42 01 11 01 00 00 02 FF	Center



Command		Command HEX	Definition
EXP_ESC	Up	42 01 15 02 00 00 00 FF	See Shutter Table
	Down	42 01 15 03 00 00 00 FF	
	Direct	42 01 15 01 00 qr st FF	
	Auto	42 01 15 01 00 00 00 FF	
Brightness	Reset	42 01 01 04 00 00 00 FF	0 to 255, default 128 qr:00 to FF
	Direct	42 01 01 01 00 00 qr FF	
Contrast	Reset	42 01 02 04 00 00 00 FF	0 to 63, default 19 qr: 00 to 3F
	Direct	42 01 02 01 00 00 qr FF	
Saturation	Reset	42 01 03 04 00 00 00 FF	0 to 63, default 31 qr: 00 to 3F
	Direct	42 01 03 01 00 00 qr FF	
Sharpness	Reset	42 01 05 04 00 00 00 FF	0 to 31, default 5 qr: 00 to 1F
	Direct	42 01 05 01 00 00 qr FF	
Reset_to_Default		42 01 80 04 00 00 00 FF	Reset above 4 to Default value
WB Mode	Auto	42 01 0C 01 00 00 00 FF	Set WB to be auto or manual
	Manual	42 01 0C 01 00 00 01 FF	
WB Value	Direct	42 01 0D 01 00 00 qr FF	0 to 255, 128 default qr: 0x00 - 0xff Only works if WB is in manual mode
	Increment	42 01 0D 02 00 00 00 FF	
	Decrement	42 01 0D 03 00 00 00 FF	
	Reset	42 01 0D 04 00 00 00 FF	
Gamma	Reset	42 01 06 04 00 00 00 FF	Reset
	Direct	42 01 06 01 00 00 0q FF	0 to 2, default 1 q: 0-2
Hue	Reset	42 01 17 04 00 00 00 FF	neg 180 to 180, default 0 v: 0 for positive, 1 for negative. qr: 00 - B4
	Direct	42 01 17 01 0v 00 qr FF	



Command		Command HEX	Definition
Pan	Disabled		Disabled in 1080 Resolution
	Reset	42 01 08 04 00 00 00 FF	Reset to 0
	Direct	42 01 08 01 0v qr st FF	<p>Called Pan in UVC; Uses sensor windowing to adjust which part of the frame is shown.</p> <p>Limits are:</p> <ul style="list-style-type: none"> •1080p: Not available, always show full image •720p, Zoom = 1: <ul style="list-style-type: none"> oMax, min X = +/- 320 This is (1920-1280)/2 qr st: 00 00 - 01 40 v: 1 = negative 0 = positive •480p (USB Mode), Zoom = 2: <ul style="list-style-type: none"> oMax, min X = +/- 640 This is (1920-640)/2 qr st: 00 00 - 02 80 v: 1 = negative 0 = positive
Tilt	Disabled		Disabled in 1080 Resolution
	Reset	42 01 09 04 00 00 00 FF	Reset to 0
	Direct	42 01 09 01 0v qr st FF	<p>Called Tilt in UVC; Uses sensor windowing to adjust which part of the frame is shown.</p> <p>Limits are:</p> <ul style="list-style-type: none"> •1080p: Not available, always show full image •720p, Zoom = 1: <ul style="list-style-type: none"> oMax, min Y = +/- 180 This is (1080-720)/2 qr st: 00 00 - 00 B4 v: 1 = negative 0 = positive •480p (USB Mode), Zoom = 2: <ul style="list-style-type: none"> oMax, min Y = +/- 300 This is (1920-480)/2 qr st: 00 00 - 01 2C v: 1 = negative 0 = positive
Save Settings	Enable	43 01 03 04 00 00 00 FF	
	Disable	43 01 03 03 00 00 00 FF	



Saturation	Reset	42 01 03 04 00 00 00 FF	0 to 63, default 31
	Direct	42 01 03 01 00 00 qr FF	qr: 00 to 3F
Sharpness	Reset	42 01 05 04 00 00 00 FF	0 to 31, default 5
	Direct	42 01 05 01 00 00 qr FF	qr: 00 to 1F
Reset_to_Default		42 01 80 04 00 00 00 FF	Reset above 4 to Default value



Inquiries:

Command	Inquiry Hex	Reply HEX	Definition
AUX_Light	43 09 01 00 00 00 00 FF	43 09 01 00 00 00 00 qr FF	% of max,(qr = 00 to 64)
Mirror_H	42 09 04 00 00 00 00 FF	42 09 04 00 00 00 00 0q FF	q: 0 = No mirroring 1 = Horizontal mirror 2 = Vertical mirror 3 = Horizontal and vertical
Frame_Rate	42 09 0A 00 00 00 00 FF	42 09 0A 00 00 00 00 qr FF	1 - 30 qr: 01 to 1E in 1080p 1 -60 qr: 01 to 3C in 720p 1 - 120 qr: 01 to 78 in 480p
EXP_ROI	42 09 11 00 00 00 00 FF	42 09 11 00 00 00 00 FF	Full
	42 09 11 00 00 00 00 FF	42 09 11 00 00 00 01 FF	Middle
	42 09 11 00 00 00 00 FF	42 09 11 00 00 00 02 FF	Center
EXP_ESC	42 09 15 00 00 00 00 FF	42 09 15 00 00 00 00 FF	Auto
	42 09 15 00 00 00 00 FF	42 09 15 00 00 00 qr st FF	qr st: See Shutter Table
Brightness	42 09 01 00 00 00 00 FF	42 09 01 00 00 00 00 qr FF	0 to 255 qr: 00 to FF
Contrast	42 09 02 00 00 00 00 FF	42 09 02 00 00 00 00 qr FF	0 to 63 qr: 00 to 3F
Saturation	42 09 03 00 00 00 00 FF	42 09 03 00 00 00 00 qr FF	0 to 63 qr: 00 to 3F
Sharpness	42 09 05 00 00 00 00 FF	42 09 05 00 00 00 00 qr FF	0 to 31 qr: 00 to 1F
WB Mode	42 09 0C 00 00 00 00 FF	42 09 0C 00 00 00 00 0q FF	q: 0 - auto 1 - manual
WB Value	42 09 0D 00 00 00 00 FF	42 09 0D 00 00 00 00 qr FF	0 to 255 qr: 00 to ff
Gamma	42 09 06 00 00 00 00 FF	42 09 06 00 00 00 00 0q FF	0 to 2 q = 0-2



Command	Inquiry Hex	Reply HEX	Definition
Hue	42 09 17 00 00 00 00 FF	42 09 17 00 0v 00 qr FF	neg 180 to 180 v: 0 = Positive, 1 = Negative qr: 00 to B4
Lens_Type	42 09 1B 00 00 00 00 FF	42 09 1B 00 00 00 00 FF	Lens A
		42 09 1B 00 00 00 01 FF	Lens B
		42 09 1B 00 00 00 02 FF	Lens C
		42 09 1B 00 00 00 03 FF	Lens D
		42 09 1B 00 00 00 04 FF	Lens E
		42 09 1B 00 00 00 05 FF	Lens F
		42 09 1B 00 00 00 06 FF	Lens G
Color_Correction	42 09 1A 00 00 00 00 FF	42 09 1A 00 00 00 00 FF	2800K
		42 09 1A 00 00 00 01 FF	4500K
		42 09 1A 00 00 00 02 FF	6500K
Resolution	42 09 0B 00 00 00 00 FF	42 09 0B 00 00 00 00 FF	1080
		42 09 0B 00 00 00 01 FF	720
		42 09 0B 00 00 00 02 FF	480
Zoom	42 09 07 00 00 00 00 FF	42 09 07 00 00 00 0q FF	q : 0 =Off, 1 = On
Pan	42 09 08 00 00 00 00 FF	42 09 08 00 0v qr st FF	720: neg 320 to 320 480: neg 640 to 420 v: 0 = Positive, 1 = Negative, qr st: 720: 00 00 to 01 40 480: 00 00 to 02 80
Tilt	42 09 09 00 00 00 00 FF	42 09 09 00 0v qr st FF	720: neg 180 to 180 480: neg 300 to 300 v: 0 = Positive, 1 = Negative qr st: 720: 00 00 to 00 B4 480: 00 00 to 01 2C



Command	Inquiry Hex	Reply HEX	Definition
Read P Version	43 09 E0 00 00 00 00 FF	43 09 EE 00 00 qr st FF	Returns PIC Version qr st in hex. LCD shows in decimal.
Read E Version	43 09 E1 00 00 00 00 FF	43 09 EE 00 00 qr st FF	Returns EM Version qr st in hex. LCD shows in decimal.

Shutter Table:

The shutter increment and decrement functions have 26 total steps as seen in the following table. The shutter value can be set to any value between 1/1 to 1/30000 using the direct command. If the shutter value is set to a different value than one in the table, the increment and decrement commands will set the shutter value to the next highest or next lowest shutter step respectively. If the shutter is given a decrement command while at shutter value 1/1 the shutter value will go into auto mode.

Shutter Value	qr Value	st Value
1/1	00	01
1/2	00	02
1/3	00	03
1/4	00	04
1/8	00	08
1/15	00	0F
1/25	00	19
1/30	00	1E
1/50	00	32
1/60	00	3C
1/100	00	64
1/250	00	FA
1/500	01	F4
1/1000	03	E8
1/2000	07	D0
1/3000	0B	B8
1/4000	0F	A0
1/5000	13	88
1/6500	19	64
1/8000	1F	40
1/10000	27	10
1/12500	30	D4
1/15000	3A	98
1/17500	44	50
1/20000	4E	20
1/30000	75	30



Specifications

Camera Head

Image Sensor	1/6 CMOS 2MP		
Active Array (H x V)	1920 x 1080		
Image Area (mm)	2.73 x 1.55		
Output Format	1080/30P	720/60P	VGA/120
Output Type	DVI & USB	DVI & USB	USB
Environmental	Temperature	RH	
Operational	0 to 60 C	90% non condensing	
Storage	neg 20 to 85 C	non condensing	
Weight	3 g	without cable	

Camera Cable

	PVC	PFA
Temperature	neg 55 to 105 C	neg 65 to 210 C
Length	15 m max	15 m max
Weight	31 g/m	24g/m
Diameter	4.1 mm	3.7 mm

Camera Control Unit (CCU)

Power Supply (USB 3 C)	5V 1A	with LED driver active
Environmental	Temperature	RH
Operational	0 to 60 C	90% non condensing
Storage	negative 20 to 85 C	non condensing
Size	87 x 47 x 170	W x H x L
Weight	370 g	
Remote communications	RS232	
	Still Photo Capture	
Output 1	DVI	1080/30p & 720/60p
Output 2	USB 2	1080/30p, 720/60p, 640x480/120p
LED driver output		
constant current P/S	Up to 1A @ 8VDC	10 step control

LED Output (CCU)

LED Step	Current (mA)
1	120
2	140
3	170
4	190
5	220
6	315
7	424
8	522
9	782
10	1081

Controller & Camera Mechanical Specifications (Non-LED Version)

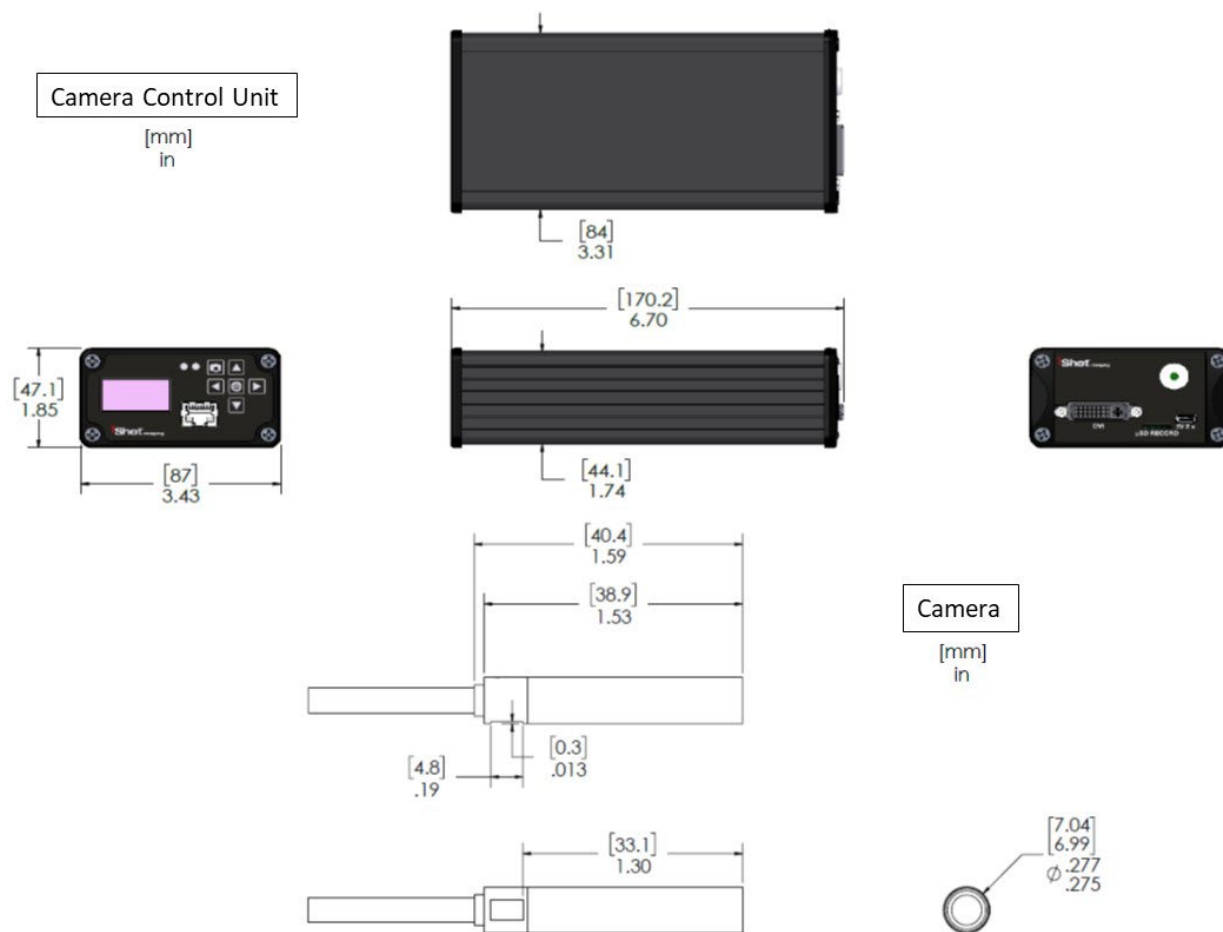

Figure 8 Non-LED Version CCU & Camera Dimensions

Controller & Camera Mechanical Specifications (LED Version)

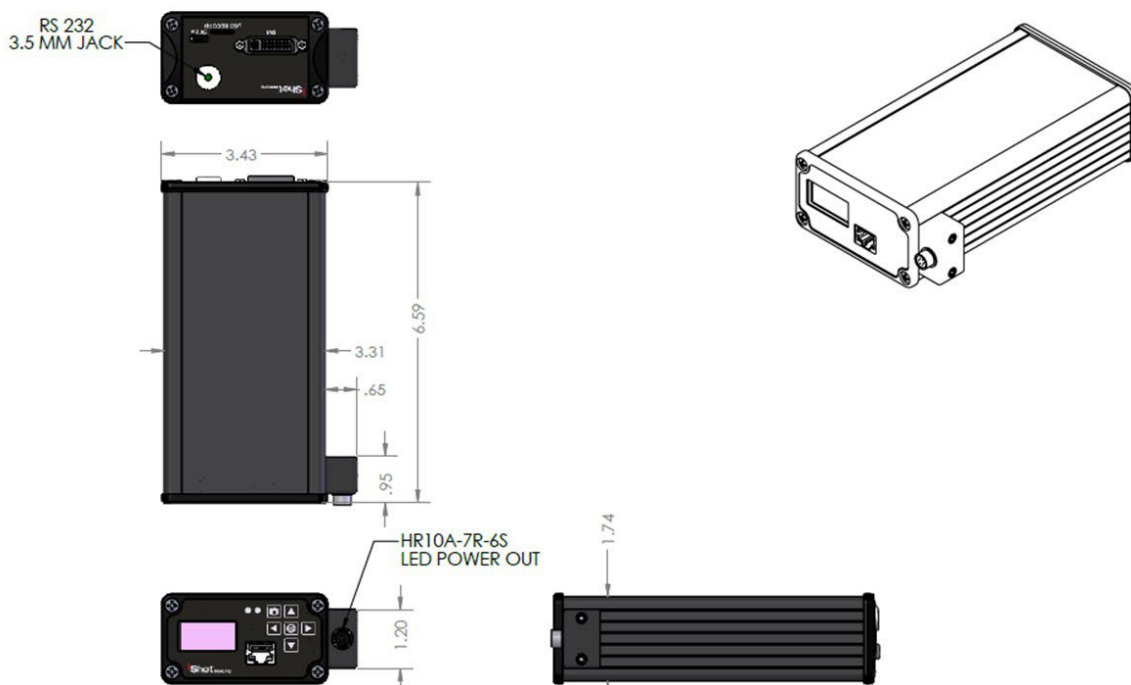

Figure 9 LED Version CCU Dimensions



Figure 10 LED Version CCU Pin Out



Control Menu Values & Defaults

Menu Tier	Item	Sub Item	Sub sub item	Values	Default	
1	Image Quality					
		Brightness		0 to 255	128	
		Contrast			0 to 63	19
		Saturation			0 to 63	31
		Sharpness			0 to 31	5
		Return to Main				
		White Balance	auto			x
			set		0 to 255	
		Gamma			0, 1, 2	1
		Hue			-180 to 180	0

Menu Tier	Item	Sub Item	Sub sub item	Values	Default	
2	Capture setup	Mirror		No, H, V, HV	No	
		Frame rate (fps)	auto		x	
				set	1 to 30 Hz in 1080	
					1 to 60 Hz in 720	
			(USB 2 only)		1 to 120 Hz in VGA	
			Exp ROI		full, middle, center	
			Exp Sec	auto		x
				set	auto, 1, 1/2, 1/3, 1/4,	
					1/5, 1/6, 1/7, 1/8, 1/9,	
					1/10, 1/15, 1/20, 1/25,	
					1/30, 1/50, 1/60, 1/100,	
					1/120, 1/250, 1/500,	
					1/1000, 1/5000,	
					1/10000, 1/20000,	
					1/30000	
			Return to Main			



Menu Tier	Item	Sub Item	Sub sub item	Values	Default
3	Utility menu				
		LED level	0 to 10		
		Show Diagnostics	H1	pass, fail	
			H2	pass, fail	
			UART com	pass, fail	
			PCB Temp	°C	
			I2C error	pass, fail	
			Ev	1.112	
			Pv	0.58	
		Save Presets			
			Save Setup 1		
			Save Setup 2		
			Save Setup 3		
			Save Setup 4		
			Return to utility menu		
		Load Presets			
			Custom setup 1		
			Custom setup 2		
			Custom setup 3		
			Custom setup 4		
			Return to utility menu		
		Lens correction			
			lens type	1.8, 2.5, 4, 8, 15	
			Color temp	2000, 4500, 6500K	

Menu Tier	Item	Sub Item	Sub sub item	Values	Default
4	Pan Tilt Zoom Menu				
		Resolution		1080p/30	x
				720p/30	
				480	
		Zoom	(in down scale modes only)	on/off	
		Pan		+,- 640 in VGA	
				+,- 320 in 720	
		Tilt		+,- 640 in VGA	
				+,- 320 in 720	

Menu Tier	Item	Sub Item	Sub sub item	Values	Default
5	Set to Defaults				
		InterTest			
		Reset to Defaults			
		Confirm			
		Return to Main			



Care & Maintenance

Overall System

- Do not expose to moisture or direct sunlight.
- Do not operate near intense electromagnetic fields.

Trouble Shooting

- Ensure camera connection is tight and secure.
- Ensure power is proper voltage and current for unit, and connection is tight and secure.
- Ensure DVI connection is tight and secure.
- Ensure MicroSD memory Card is firmly in place.
- Ensure a proper lens is in place on camera.
- Ensure all menu settings are as desired and correct for equipment in use.
- Restart - disconnect power supply and reconnect power supply

Returns for Repair or Service

In the event a product is damaged and needs repair, send it to the Service Department at the main office in Columbia, NJ. An RMA (Return Material Authorization Number) must be issued prior to the unit being returned. **Call InterTest, Inc. at (908) 294-8008 to obtain an RMA Number.** Shipments returned without an RMA will have an administrative fee applied to the transaction.

Provide the product number, serial number and a brief description of the problem or damage when obtaining an RMA number

Return Evaluation Procedure

Once a return is received by InterTest, Inc. it will be evaluated. The fee for any repair evaluation not sent in under warranty is \$55 (USD credited against cost of repair). This cost is in addition to any other charges required. Prior to any repairs being completed, a repair evaluation will be issued and payment arranged. Payment via credit card is preferred and will expedite the repair process.

Once payment is arranged, the authorization to repair the product is given. Completed repairs will ship back to the customer using the pre-arranged shipping methods.



For Service of this product:

InterTest, Inc.

303 State Route 94

Columbia, NJ 07832

1-800-535-3626

+1 908 496 8008

Email: service@intertest.com

Internet: <http://www.intertest.com>



Parts and Accessories

Intertest PN	Description
EM17541	iShot QNHD Control Unit w/ LED Output
EM14515	iShot QNHD Control Unit
EM15681	4 GB Micro SD Card with Adapter
EM15685	16 GB Micro SD Card with Adapter
EM15680	32 GB Micro SD Card with Adapter
EM19884	64 GB Micro SD Card with Adapter
EM16937	DVI (M) to HDMI (F) Type A Adapter
EM13340	iShot® QNHD Camera 2M PVC Cable
EM13342	iShot® QNHD Camera 2M Teflon Cable
EM13582	iShot® QNHD Camera 3.5M PVC Cable
EM13584	iShot® QNHD Camera 3.5M Teflon Cable
EM13246	iShot® QNHD Camera 5M PVC Cable
EM13343	iShot® QNHD Camera 5M Teflon Cable
EM15203	iShot® QNHD Camera 5.5M PVC Cable
EM15230	iShot® QNHD Camera 7.5M PVC Cable
EM13341	iShot® QNHD Camera 10M PVC Cable
EM13344	iShot® QNHD Camera 10M Teflon Cable
EM13583	iShot® QNHD Camera 15M PVC Cable
EM13585	iShot® QNHD Camera 15M Teflon Cable
EM13581	iShot® QNHD Power Supply, USB-C
EM13474	iShot® 1.8mm Lens for QNHD Cam (90 Deg)
EM13475	iShot® 2.5mm Lens for QNHD Cam (60 Deg)
EM13476	iShot® 4.0mm Lens for QNHD Cam (40 Deg)
EM13497	iShot® 7.1mm Lens for QNHD Cam (20 Deg)
EM13477	iShot® 15.0 mm Lens for QNHD Cam (10 Deg)
EM15138	iShot® W/P Housing FOR QNHD
EM69477	DB9F - DC3.5M Serial Cable



Admin Section

This section of the manual is intended for high level users that take responsibility for use at an OEM level. Settings, programming, and remote communication through RS 232 allow expanded use.

Caution: users at this level are beyond warranty coverage. Note there are ESD sensitive components.

Contact InterTest tech support, service@intertest.com, for further details.

Dip Switch Settings

<i>Dip Switch</i>	<i>1,2,3,4 Not Used</i>	ON	OFF
5	Enable/Disable Preset Saving	Locked (Save disabled)	Unlocked (Save enabled)
6	AEQ Report Mode	Cable testing mode	Normal Operation
7	Transport Chip Update Control (Switch 8 must be "OFF")	954 Transport Chip	914 Transport Chip
8	Run / Programming Mode	Run Mode	Transport Chip Programming Mode

Main Menu

Line	Text	Notes	FirstVersion
0	** Intertest QN HD **		0
1	Main Menu	Top level menu	0
2	<i>Image Quality</i>	Image quality related	0
3	<i>Capture Setup</i>	Image capture related: FPS, Exposure, Mirroring	0
4	<i>Utility Menu</i>	LED Level, Diagnostics, Save Preset, Load Preset	0
5	<i>Pan-Tilt-Zoom</i>	Resolution, Zoom, Pan, Tilt	0
6			
7	<i>Reset to defaults</i>		0
	<i>Bold-Italics means item is a submenu</i>		
	Control ID provided for commands that go to the ISP		



Image Menu

Line	Text	Control ID	Notes	Default	FirstVersion
0	** Intertest QN HD **				
1	Image Quality			Default	FirstVersion
2	Brightness	0x01	Brightness adjustment	0x80	0
3	Contrast	0x02	Contrast adjustment	19	0 Default changed in 0.58
4	Saturation	0x03	Saturation adjustment	0x1F	0
5	Sharpness	0x05	Sharpness adjustment	5	0 Default changed in 0.58
6	<i>More ...</i>		More adjustments in this submenu		0
7	Return to Main		Return to Main menu		0
<i>Bold-Italics means item is a submenu</i>					
Control ID provided for commands that go to the ISP					

More Image Quality

Line	Text	Control ID	Notes	Default	FirstVersion
0	** Intertest QN HD **				0
1	More Image Quality...				0
2	White Balance Mode	0x0C	Auto/Manual		0
3	White Balance Level	0x0D	Blue <----> Red		0
4	Gamma	0x06	Non-linear gain	0x00	0
5	Hue	0x17	Hue adjustment	0x00	0
6					Compression removed 0.58
7	Return to Image Quality				0

Capture Menu

Line	Text	Control ID	Default	Notes	Default	FirstVersion
0	** Intertest QN HD **					
1	Capture Menu					
2	Mirroring	0x04		None, H, V, HV	0x00	0
3	Frame Rate	0x0A		1-30fps in 1080, 1-60 in 720, 1-120 in 480	0x00	0
4	Exp ROI: Full, Mid, Center	0x10, 0x11, 0x12, 0x13		Full = 5x5 equally weighted; Middle = Central 3x3 extra weighted; Center = Central 1x1 extra weighted		0
5	Exp Time: Auto/Manual	0x15		Choose Automatic or set the exposure time {1s, 1/2s, 1/3 1/4, 1/5, 1/6, 1/7, 1/8, 1/9, 1/10, 1/15, 1/20, 1/25, 1/30, 1/50, 1/60, 1/100, 1/120, 1/250, 1/500, 1/1000, 1/5000, 1/10000, 1/20000, 1/30000s}		0
6						
7	Return to Main					0
<i>Bold-Italics means item is a submenu</i>						
Control ID provided for commands that go to the ISP						



Utility Menu

Line	Text	Control ID	Notes	Default	FirstVersion
0	** Intertest QN HD **				0
1	Utility Menu				0
2	LED Level	N/A	Off-10 where 10=1A. Works for LEDs upto a total of <8V in series.		0
3	<i>Diagnostics</i>	N/A	I2C Test, Lock Status, PCB Temp		0
4	<i>Save Preset</i>	N/A	4 user presets		0
5	<i>Load Preset</i>	N/A	4 user presets		0
6	<i>Lens Correction</i>	N/A	New in 0.56, replaces Serial Number		0.56
7	Return to Main				0
	<i>Bold-Italics means item is a submenu</i>				
	Control ID provided for commands that go to the ISP				

Save Preset

Line	Text	Control ID	Notes	FirstVersion
0	** Intertest QN HD **			0
1	Save Preset			0
2	User Setup 1	N/A	Save to user 1	0
3	User Setup 2	N/A	Save to user 2	0
4	User Setup 3	N/A	Save to user 3	0
5	User Setup 4	N/A	Save to user 4	0
6				
7	Return to Utility			0
	<i>Bold-Italics means item is a submenu</i>			
	Control ID provided for commands that go to the ISP			



Load Preset

Line	Text	Control ID	Notes	FirstVersion
0	** Intertest QN HD **			0
1	Load Preset			0
2	User Setup 1	N/A	Save to user 1	0
3	User Setup 2	N/A	Save to user 2	0
4	User Setup 3	N/A	Save to user 3	0
5	User Setup 4	N/A	Save to user 4	0
6				
7	Return to Utility			0
	<i>Bold-Italics means item is a submenu</i>			
	Control ID provided for commands that go to the ISP			

Diagnostics

<i>Bold-Italics means item is a submenu</i>	Each hex digit yields 4 bits in binary:		
Control ID provided for commands that go to the ISP	Dec	Hex	Binary
	0	0	0000
Interpreting I2C Error Codes:	1	1	0001
The code is presented as a 1 byte number in Hex	2	2	0010
Convert the Hex code to Binary	3	3	0011
Each bit indicates the pass/fail status of a device on the I2C bus	4	4	0100
Bit 0 = Deserializer	5	5	0101
1 = Serializer	6	6	0110
2 = MIPI Bridge	7	7	0111
3 = Image Sensor	8	8	1000
4 = DVI output chip	9	9	1001
5 = Thermometer	10	A	1010
6 = I2C DAC for LED Level control	11	B	1011
7 = EEPROM	12	C	1100
	13	D	1101
1 in the bit indicates pass.	14	E	1110
So for example 0xF7 indicates that everything passed except the image sensor.	15	F	1111



PTZ Menu

Line	Text	Control ID	Notes	Default	FirstVersion
0	** Intertest QN HD **				0
1	PTZ Menu				0
2	Resolution	0x0B	Select this to change the camera resolution, however host has to query for it to take	0x00	0
3	Zoom	0x07	Available in 720/480 mode only. Currently this is set to crop only, which is zoom on or reduced FOV, and at a higher frame rate (60, 120 for 720,480 respectively). By software update it will allow the option for scaling (keep full FOV), at which point this control will do something. It is active but lined-out in the GUI right now.	0x00	0.4
4	Pan	0x08	If not in 1080 and zoom is enabled then this allows horizontal pan	0x00	0
5	Tilt	0x09	If not in 1080 and zoom is enabled then this allows vertical pan	0x00	0
6					
7	Return to Main				0
	<i>Bold-Italics means item is a submenu</i>				
	Control ID provided for commands that go to the ISP				
	Yellow highlighted cells denote controls that are new in this version.				

Reset to Defaults

Line	Text	Control ID	Notes	FirstVersion
0	** Intertest QN HD **			0
1	Reset to Defaults			0
2	Confirm	N/A	Select confirm to reset	0
3				
4				
5				
6				
7	Return to Main		Select to exit	0
	<i>Bold-Italics means item is a submenu</i>			
	Control ID provided for commands that go to the ISP			



Lens Correction

Line	Text	Control ID	Notes	Default	FirstVersion
0	** Intertest QN HD **				0
1	Lens Correction				0
2	Lens Type	N/A	TBD	0	0
3	Color Temp	N/A	2800, 4500, 6500K options (0,1,2)	0	0
4					
5					
6					
7	Return to Utility				0
	<i>Bold-Italics means item is a submenu</i>				
	Control ID provided for commands that go to the ISP				

Circuit Board Layout / Connections

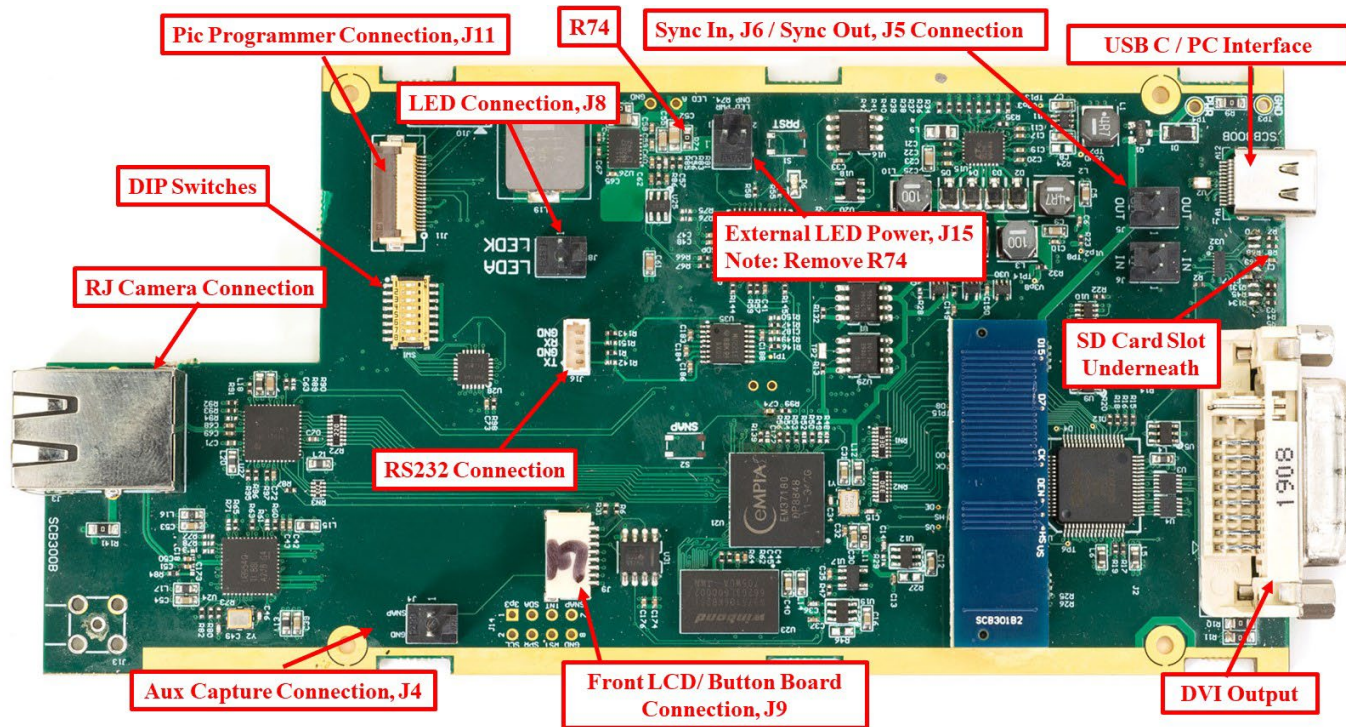

Figure 11 CCU Circuit Brd Layout

Connector	Label/Silkscreen
<i>J4</i>	<i>Aux Capture</i>
	Pin 1, Input
	Pin 2, GRND
<i>J8</i>	<i>LED Output</i>
	LED_A +
	LED_K -
<i>J16</i>	<i>RS232</i>
	Pin 1, Tx
	Pin 3, Rx
	Pin 2 & 4 GRND
<i>J5**</i>	<i>Sync Out</i>
	Pin 1, Signal
	Pin 2, GRND
<i>J6**</i>	<i>Sync In</i>
	Pin 1 Signal
	Pin 2 GRND
<i>J15</i>	<i>Ext LED Power</i>
	Pin 1 +
	Pin 2 -
	Must Remove R74

Figure 12 Connector Pin Out

****Note: Sync IN & Sync OUT are programable Input/Output Connections**

SCB300B Firmware Upload Procedure

The SCB300B board allows for both the old and new SerDes to be used and automatically detected when plugged in to the RJ45 jack. In order to do this we must program both the versions of the ISP (EM37180) code into the correct SPI Flash for the system to work properly. In order to make this easy there is a new firmware programming mode that has been added to the PIC firmware (v1.02+) that is accessed via the DIP switches on the SCB300B board.

To use the Firmware programming mode:

- 1. Set DIP8 to the OFF position o Normally DIP8 will be in the ON position to run the camera (Pv1.02+)
- 2. Set DIP7 to OFF for the Old 914 SerDes or to ON for the New 954 SerDes
- 3. Then power on the board using a PC
- 4. The LCD screen should show either 914 or 954 depending on what was set on DIP7
- 5. If it shows a regular main menu then DIP8 is in the ON position. Turn it off and cycle power.
- 6. Start the EM_Download_Tool software o The tool should say "USB Init OK" at the top
- 7. Select "Browse" and navigate to the supplied *914*.bin or *954*.bin file depending on



- which you are trying to program
- 8. Select "Download" and within ~10 seconds the download should be successfully completed
- 9. If you want to program the other SerDes then flip DIP7 and power cycle the board, following from step 3 onwards.
- 10. Once you have programmed both Flash chips set DIP8 to the ON position to enter RUN mode next time you power cycle the board.

SCB300B AEQ Procedure

The SCB300B board adds a new AEQ mode that replaces the special firmware we had for the SCB300A.

This AEQ mode is accessed by setting DIP6 to the ON position, but follow the steps below for best results.

1. Set DIP6 to the OFF position (this is normal running mode).
2. Power up the board with the camera head you wish to measure connected
3. Once the system is up and running and you see an image flip DIP6 to the On position
4. Within a few seconds you should see the LCD screen readout an AEQ value a. It will tell you which camera head was detected
 - b. If there is no camera it will say there is no lock
 - c. At this point you can unplug/replug cameras to redo AEQ measurements but the most reliable measurement is made with the camera plugged in before powering on the system, and with AEQ mode off at first and then turned on after the camera is running.
5. You can turn off AEQ mode by flipping DIP6 to the Off position. The main menu will return.

