



InterTest, Inc.
 303 Route 94
 Columbia, NJ 07832 USA
 +1 908 496-8008
 intertest.com/

PC-HD15

CAMERA SPECIFICATIONS

The PC-HD15 camera was designed for a variety of industrial applications. It can be utilized as a standalone device or easily incorporated into a larger solution as an OEM system without giving up performance. The camera housing is 15mm diameter made from anodized black aluminum with lens locking ring. The camera utilizes a 1080p full HD 1/4.4" CMOS sensor with an electronic rolling shutter at speeds up to 1/100,000 per second and adjustable exposure. An M12 lens mount allows for a variety of swapable lenses for a multitude of viewing options. A connectorized unit is available along with a permanently tethered unit for reduced rigid length to cable bend.

Multiple options are available for the control unit including a portable 7" Monitor Controller or a Desktop Controller made from rugged anodized black aluminum with non-slip rubber feet. Both options include built in storage and DVR with full image capture, recording and playback capabilities along with multiple outputs.

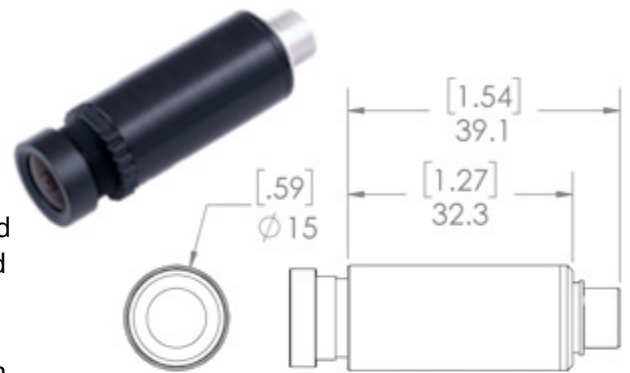

Connectorized Unit



Tethered Unit



Monitor Controller

Units shown with M12 lens
 (not included)

Image Sensor	1/3" CMOS
Total Pixels	2304 H x 1536 V
Active Pixels	2304 H x 1296 V
Pixel Size	2.2µm x 2.2µm
Sensing Area	5.07mm H x 3.38mm V
Synchronization	Internal
Sensitivity	0.2 lux (30 IRE)/F1.2
Responsivity	2.0V/lux-sec
Scanning Mode	Progressive
Shutter Type	ERS
Shutter Speed	Auto: 1/60 ~1/100,000 sec
Back Light Compensation	Auto
Dynamic Range	69.5 dB
Signal to Noise Ratio	39 dB
Gain Control	Auto (switching)
White Balance	Auto
Operating Temperature	-20°C~70°C
Storage Temperature	-30°C~90°C
Cable Length	3m-15m [9.84'-49.21']
Lens Mount	M12
Power Consumption	< 200mA

*See controller documentation for complete system specifications