



InterTest, Inc.  
303 Route 94  
Columbia, NJ 07832 USA  
+1 908 496-8008  
intertest.com/

# PC-HD15

## CAMERA SPECIFICATIONS

The PC-HD15 camera was designed for a variety of industrial applications. It can be utilized as a standalone device or easily incorporated into a larger solution as an OEM system without giving up performance. The camera housing is 15mm diameter made from anodized black aluminum with lens locking ring. The camera utilizes a 1080p full HD 1/4.4" CMOS sensor with an electronic rolling shutter at speeds up to 1/100,000 per second and adjustable exposure. An M12 lens mount allows for a variety of swappable lenses for a multitude of viewing options. A connectorized unit is available along with a permanently tethered unit for reduced rigid length to cable bend.

Multiple options are available for the control unit including a portable 7" Monitor Controller or a Desktop Controller made from rugged anodized black aluminum with non-slip rubber feet. Both options include built in storage and DVR with full image capture, recording and playback capabilities along with multiple outputs.

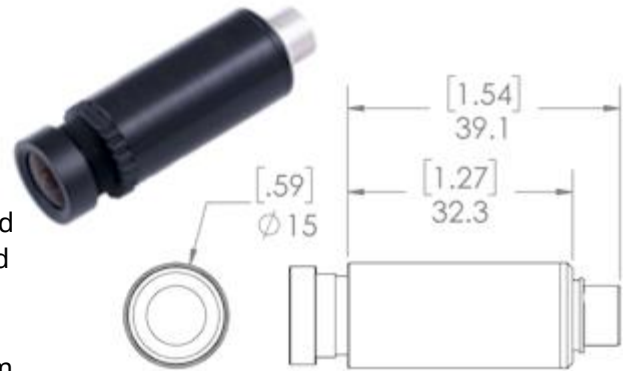

Image Sensor	1/3" CMOS
Total Pixels	2304 H x 1536 V
Active Pixels	2304 H x 1296 V
Pixel Size	2.2µm x 2.2µm
Sensing Area	5.07mm H x 3.38mm V
Synchronization	Internal
Sensitivity	0.2 lux (30 IRE)/F1.2
Responsivity	2.0V/lux-sec
Scanning Mode	Progressive
Shutter Type	ERS
Shutter Speed	Auto: 1/60 ~1/100,000 sec
Back Light Compensation	Auto
Dynamic Range	69.5 dB
Signal to Noise Ratio	39 dB
Gain Control	Auto (switching)
White Balance	Auto
Operating Temperature	-20°C~70°C
Storage Temperature	-30°C~90°C
Cable Length	3m-15m [9.84'-49.21']
Lens Mount	M12
Power Consumption	< 200mA

**\*See controller documentation for complete system specifications**