

SeeUV®



Free Standing WebViewer®

EM14838

Vertical Reach · Operation & Service Manual



To avoid injury, read and understand documentation for each system component prior to operation. Direct any questions about operation to InterTest at (908) 496-8008 or service@intertest.com

Shot®

Original Instructions



Table of Contents

iShot See UV Vertical Free Standing WebViewer - P/N EM14964

1.0	Introduction.....	3
2.0	Customer Support.....	4
3.0	Warranty.....	5
4.0	Unpacking & Inspection.....	6
5.0	Assembly.....	7
6.0	Operation.....	8
7.0	Care & Maintenance.....	16
8.0	Safety.....	17
9.0	Declaration of Conformities & Specifications.....	18
10.0	Service Record.....	24

Appendix:

ELMO CCU	25
Monitor Swing Arm.....	50
Sony Monitor.....	52
USHIO UV-LED Light Source.....	56
35-watt LED White Light Source.....	68
7" HDMI Monitor and Recorder.....	79

1.0 Introduction

Congratulations for your investment in the Free Standing WebViewer®, InterTest's portable visual inspection and web examination system. All WebViewer® systems combine high-resolution RVI instrumentation with precision camera maneuvering mechanisms.

The Free Standing WebViewer® provides the ability to visually inspect interior surfaces of components during the Fluorescent Penetrant Inspection process and the Magnetic Particle Inspection process. It is intended to make the inspection processes simpler and repeatable to perform. It increases the inspectors ability to see and to evaluate the indications.

Many features enhance the WebViewer® systems performance and versatility. These include:

Generous Movement Envelope

Manual or optional motor control, the camera boom travels typically 950mm horizontally and 500mm* vertically.

Illumination Control

In order to attain a more thorough remote visual examination of component internals, the WebViewer® systems have been designed with both white and UV light capability. Intensity is controlled independently and operation can be simultaneous.

Robust Video Camera

All WebViewer systems come with remote focus capability helping to ensure crisp, high-resolution video images. They capture color video at a resolution of 460 horizontal TV lines (PAL) or 470 horizontal TV lines (NTSC).

Near-Coincident Viewing and Illumination Vectors

To minimize viewable shadows, InterTest uses high grade optics and micro components to position the field of vision axis adjacent to the projected illumination.

**specifications can change without notice*

2.0 Customer Support

Service and support for all InterTest products is available by calling (908) 496-8008. We also welcome comments, suggestions and technical inquiries by fax at (908) 496-8004 or email: service@intertest.com

See on page 5 InterTest's one-year limited warranty on parts and materials. Be sure to read all warranty information, register your product on-line at www.intertest.com and save this manual for future reference.

If your system requires service, please contact our Customer Service team at:

Address: InterTest,
303 Route 94
Columbia, NJ 07832

Email: service@intertest.com

Phone: +1 908-496-8008
Toll free in USA - +1 800-535-3626

3.0 Warranty

InterTest, Inc. guarantees the products manufactured by InterTest, Inc. to be free from defects in materials and workmanship for a period of one (1) year, from the date of original purchase. Any and all other products not manufactured by InterTest, Inc. will carry the OEM's limited warranty, which will be passed to the purchaser through and supported by InterTest, Inc. InterTest, Inc.'s obligation under this limited warranty shall be confined to the repair or exchange of any part, or parts thereof, that prove defective under normal use and service for which the product was intended and/or designed for.

This limited warranty covers conditions that upon our examination, at our facility, shall disclose, to our satisfaction, to be defective.

This limited warranty is in lieu of all other warranties, express or implied, including the warranties of merchantability and fitness for use and of all other obligations or liabilities on our part, and we neither assume, nor authorize any other person to assume for us, any other liabilities in connection with the sale of InterTest, Inc. equipment. This warranty shall not apply to any equipment that has been subject to accident, negligence, alteration, abuse, unauthorized repair, improper storage, or other misuse.

This limited warranty applies only to the original purchaser and cannot be assigned or transferred to any third party without express written consent from InterTest, Inc.

This limited warranty does not apply to consumable items, expendable items or normal wear and tear, nor does it apply to failure due to radiation, overheating and / or below freezing temperatures.

Additionally, InterTest, Inc. assumes no responsibility, either expressed or implied, regarding the improper usage of this equipment or interpretation of test data derived from this product. InterTest, Inc.'s responsibility and obligations, in all cases, are limited strictly to the repair and/or replacement costs outlined above.

The laws of the State of New Jersey shall govern this warranty.

Note: In the event that the equipment can not be returned to InterTest, Inc., for whatever reason, the customer agrees to pay for all travel and living expenses incurred to have an InterTest, Inc. Representative evaluate, assess or affect a warranty repair in the field.

4.0 Unpacking & Inspection

Before setting up the Free Standing WebViewer® system, verify that all components and sub-assemblies are present and that none has suffered physical damage in transit.

The shipment contains:

- Free Standing WebViewer Assembly
- Necessary Power Cords and Video Cables
- Ushio UV LED Light Source
- Sony LCD Monitor
- Control Unit
- Operations and Service Manual

Remove all tape and packing material from the components. Next, carefully inspect each piece for damage and/or missing parts. Inspect all control panel knobs and switches for proper operation. If any portion of the system has suffered damage during shipment, please notify InterTest at once.

Retain all packing material for use in the event that the system or system components need to be shipped in the future.

- A.** WEBVIEWER CAMERA HEAD
- B.** CAMERA BOOM
- C.** VERTICAL MOTION MAST
- D.** VERTICAL POSITIONING KNOB & MOTOR
- E.** HORIZONTAL POSITIONING KNOB AND MOTOR DRIVE
- F.** COLOR MONITOR
- G.** SWING ARM
- H.** EMERGENCY STOP
- I.** CAMERA CONTROL UNIT
- J.** STORAGE DRAWER
- K.** WHITE LIGHT SOURCE
- L.** UV LIGHT SOURCE
- M.** POWER STRIP
- N.** CART
- O.** CASTER WHEEL WITH BRAKE

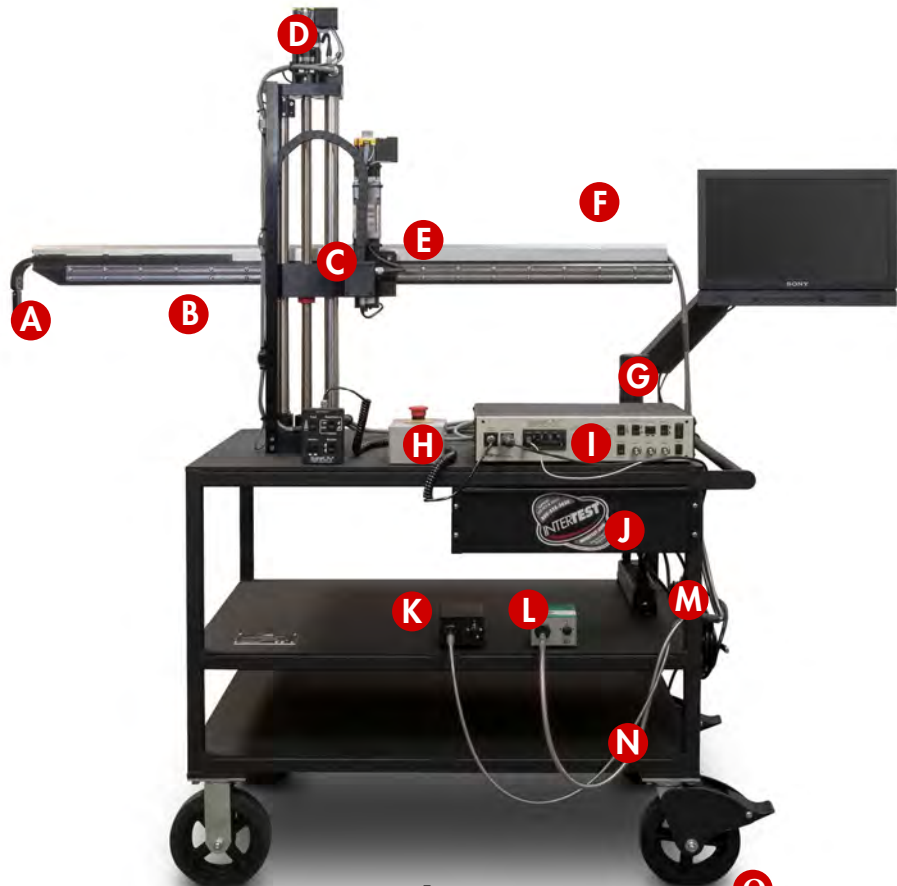

Figure 1 **O** 6

5.0 Assembly



Figure 2

5.1 Assembly Instructions

- 1) The Free Standing WebViewer® is shipped completely assembled.
- 2) Bolt the base plate to the inspection bench or cart.
- 3) Connect light guides and camera connections to their respective sources or controllers (see section 5.2)

WebViewer Head
Optical Adapter

5.2 Free Standing WebViewer® Setup

Reference the schematic (Figure 11) and the control panel layout (Figure 9 & 10)

- 1) On the control panel turn the power switch to off
- 2) Connect WebViewer® light guides White (B) and UV (A) to the respective sources
- 3) Connect WebViewer® power and control cable (C) to control unit
- 4) Connect WebViewer® camera cable (D) to control unit
- 5) Set VIBES/WebViewer® switch on the control unit to "WebViewer".

Caution: The camera cable (D) has fine pins and **MUST** be aligned with the key-way up. The outer threaded ring **MUST** be secured finger tight to control unit. **DO NOT FORCE** fit this connector pin damage may result.

5.3 Equipment Placement

Place all other components for the WebViewer® in a safe, secure location that is free from hazards. The controls for the CCU and light sources should be within easy reach for an operator standing in front of the monitor and laptop. Avoid potential pinch points at all times. Provide a generous bend radius (>50mm) for UV light guide cable.

6.0 Operation

6.1 Start Up

The components for cart based system are setup as shown in Figure 11. Refer to **5.0 Assembly** section for setup. Refer to following steps for startup.

1. Place control unit on top shelf.
2. Place white light and UV light sources on middle shelf.
3. Position monitor on the swing arm as desired. Verify that all moving parts are clear of the swing arm and monitor through full range of travel.
4. Place Emergency Stop switch within easy reach of the the operator.
5. Turn on control unit master power switch.
6. Turn on all components: white light source, UV light source, camera control unit, monitor.
7. Install appropriate optical tip adapter. See section **6.2 Tip Installation** for further details.

Figure 1 is an illustrated picture of the complete system as viewed by the operator.

8. Assure cart is positioned in proper alignment with target. Set caster wheel brakes (see Figure 1, "O")

6.0 Operation

6.2 Startup and Tip Installation

- 1) After making the connections noted in section 5.3 set power switch to on. After system boot (approximately 15 seconds) the focus and radial reach controls will operate the WebViewer® device.
- 2) Select the appropriate optical adapter and install as shown in Figures 3 - 8.



Figure 3 - Align components



Figure 4 - Align fixed and moveable pins. Note moveable pins align with slots (see pointer)



Figure 5 - Engage Pins



Figure 6 & 7 - Push and rotate pins clockwise 90° to engage counter clockwise 90° to disengage



Figure 7



Figure 8 - Installation complete. Reverse order for removal

6.0 Operation



6.3 WebViewer® Controls (see Figures 9-11)

For cart setup: Position in place and lock two wheels by pushing down on the brakes with foot. **Verify that the WebViewer® head is fully retracted before loading and unloading components to avoid system damage.**



Use a fixture to provide proper alignment of part's rotating axis and positioner's rotating axis. Verify clearance when the WebViewer® head makes entry into component. Use vertical, horizontal and radial reach controls as needed to position head.

Move the WebViewer® head with insertion, elevation and radial reach controls to a position suitable for inspection (**refer to Figure 11 on page 11**).



Insertion:

To control position of the x-axis of the WebViewer® boom, use the Control Box switch or Control Pendant switch. To insert the WebViewer® boom into the part, push  on the Control Box or Control Pendant. To retract boom out of the part, push  on the Control Box or Control Pendant. Note the speed of insertion is controlled by the knob below the Insertion switch on the Control Unit.

Elevation:

To control elevation of the y-axis of the WebViewer® boom, use the Control Box switch or Control Pendant switch. To move the WebViewer® boom down, push  on the Control Box or Control Pendant. To move the WebViewer® boom up, push  on the Control Box or Control Pendant. Note the speed of elevation is controlled by the knob below the Elevation switch on the Control Unit.

Radial Reach (WebViewer® Head Movement):

To control the radial reach of the WebViewer®, use the rocker switch on the Control Box or Control Pendant labeled 'RADIAL REACH'. To extend the WebViewer® into the web sections push  on the Control Box or Control Pendant. To retract the WebViewer® out of the web sections push  on the Control Box or Control Pendant. Note the speed of radial reach is controlled by the knob below the Radial Reach switch on the Control Unit.

Camera Controls:

Adjust the camera's focus using the focus control found on the Control Box. Switch between the Normal and Mirrored views using the rocker switch on the Control Box. (refer to page 12 for more details.)

6.0 Operation

Control Box Front Panel

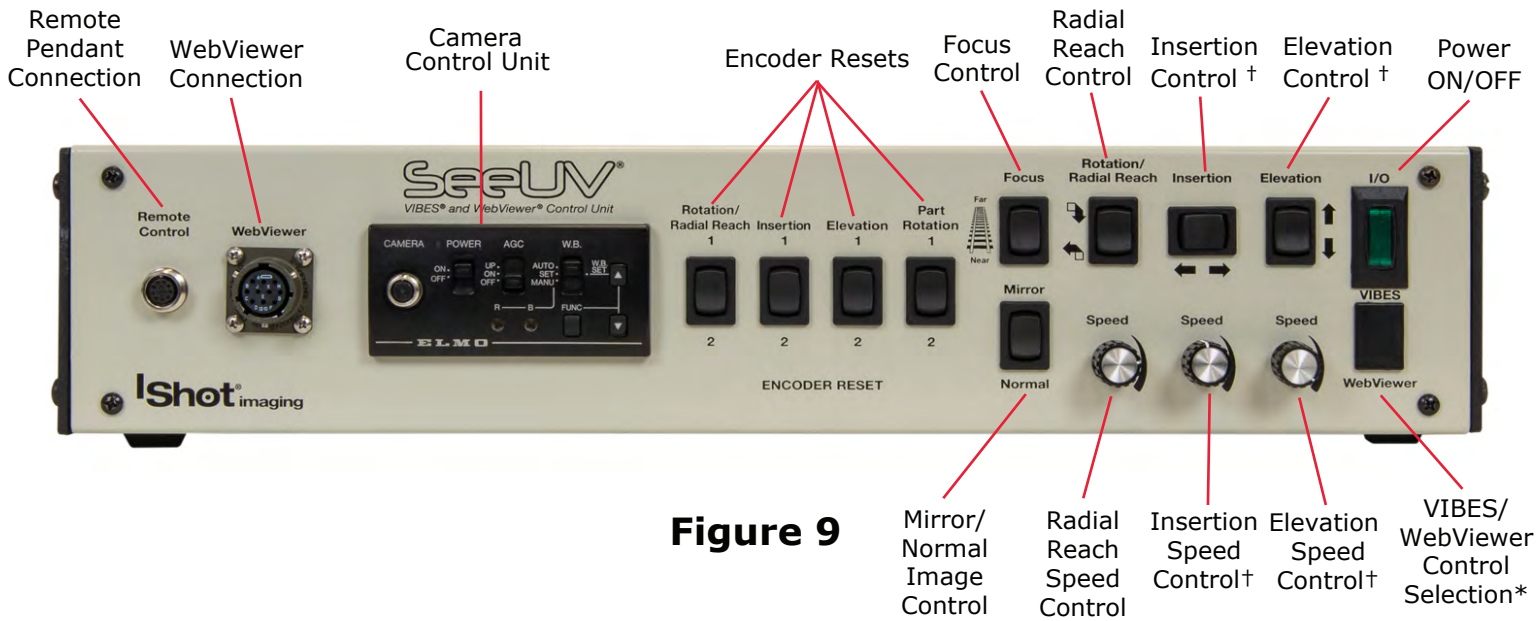

Figure 9

Control Box Rear Panel

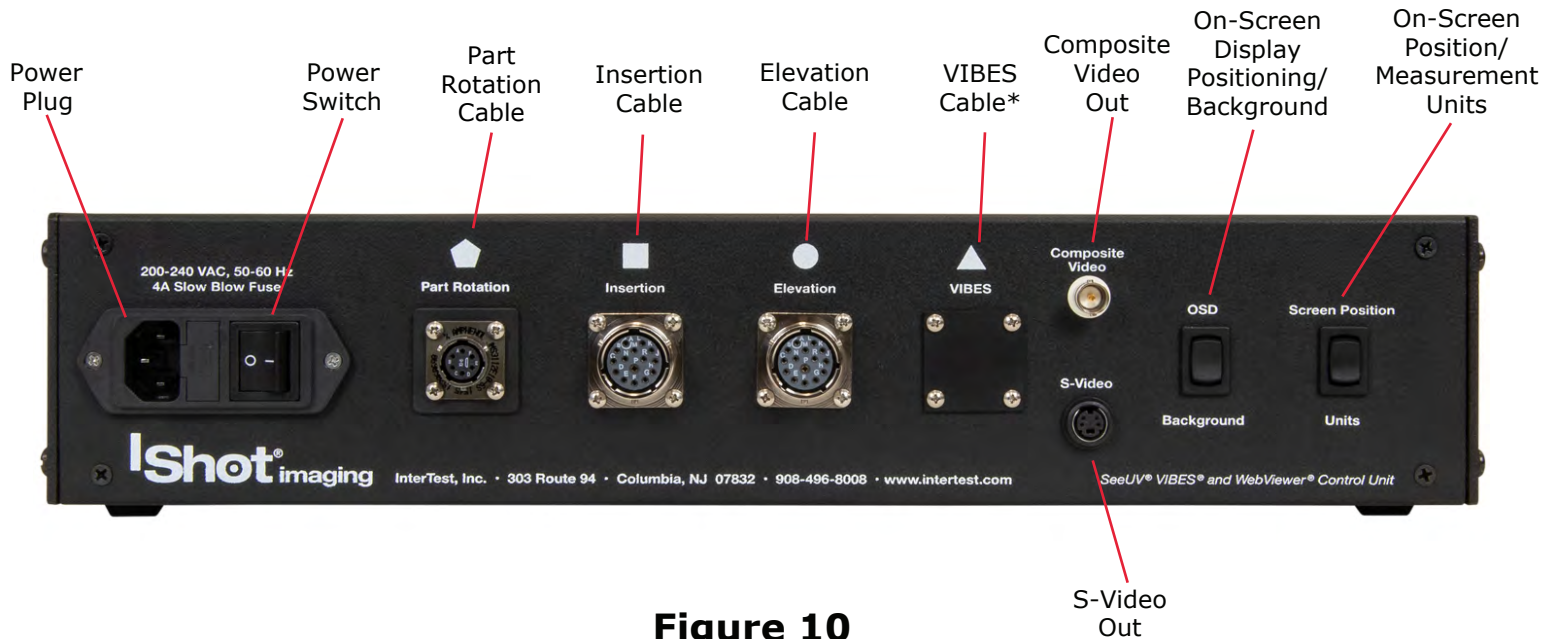

Figure 10

Note: Specifications may be different than pictured above.

* Option available for VIBES/WebViewer System

† Motorized, Insertion and Elevation controls are added options.

- = Insertion Cable connection for motorized/encoded control cable.
- = Elevation Cable connection for motorized/encoded control cable.
- ◼ = Part Rotation Cable connection for encoded control cable.
- ▲ = VIBES Cable connection for VIBES control option.

6.0 Operation

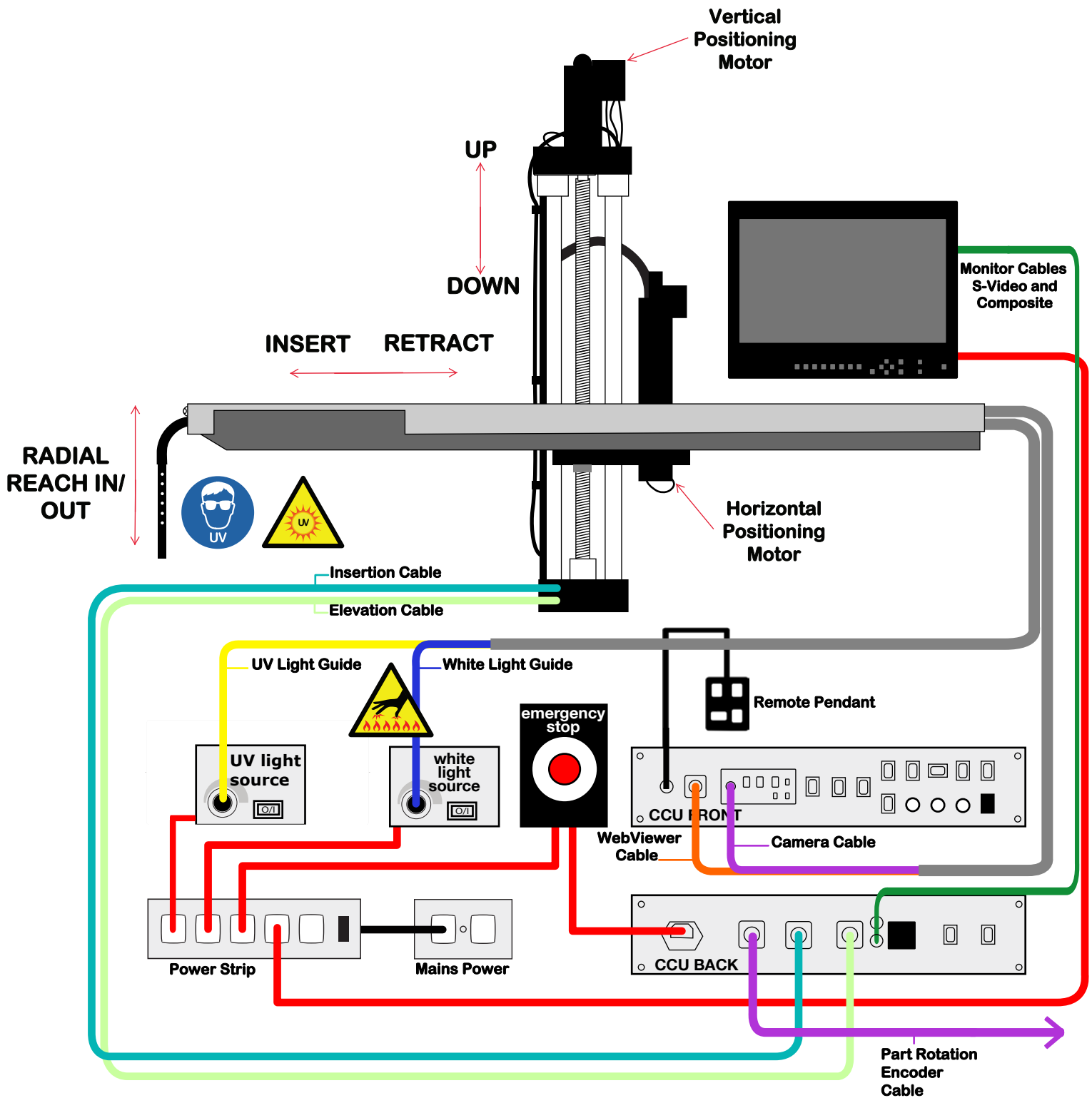

Figure 11

Illustration not to scale and does not show cart. Specifications may be different than pictured above.

6.0 Operation

6.4 Operation Control List

Refer to Figure 9

Main Control Box Features	Control Function
FOCUS	Focus image on screen near and far
ROTATION/RADIAL REACH	Inserts/retracts WebViewer® Camera head
INSERTION	Motorized movement of WebViewer® boom along x-axis
ELEVATION	Motorized movement of WebViewer® boom along y-axis
I/O	Power on/off
MIRROR/NORMAL	Flips image to mirror mode and flips back to normal
SPEED (under ROTATION/RADIAL REACH)	Increase/decrease speed of WebViewer® Camera head radial reach
SPEED (under INSERTION)	Increase/decrease speed of WebViewer® boom movement along x-axis
SPEED (under ELEVATION)	Increase/decrease speed of WebViewer® boom movement along y-axis
VIBES/WEBVIEWER	Choose between VIBES controls and WebViewer® Controls

Refer to Figure 11

Manual Control Features	Control Function
Horizontal Positioning Handle*	Manually moves WebViewer® boom along x-axis. Counter-clockwise moves boom left, clockwise moves boom right
Vertical Positioning Handle*	Manually moves WebViewer® boom along y-axis. Counter-clockwise moves boom down, clockwise moves boom up
Brakes on Cart	Locks cart position

Refer to Figure 12

Pendant Control Features	Control Function
FOCUS	Focus image on screen near and far
RADIAL REACH	Inserts/retracts WebViewer® Camera head
INSERTION	Motorized movement of WebViewer® Boom along x-axis
ELEVATION	Motorized movement of WebViewer® Boom along y-axis

*Only for manual horizontal and/or vertical positioning versions

13

6.0 Operation

6.4 Operation Control List (continued)

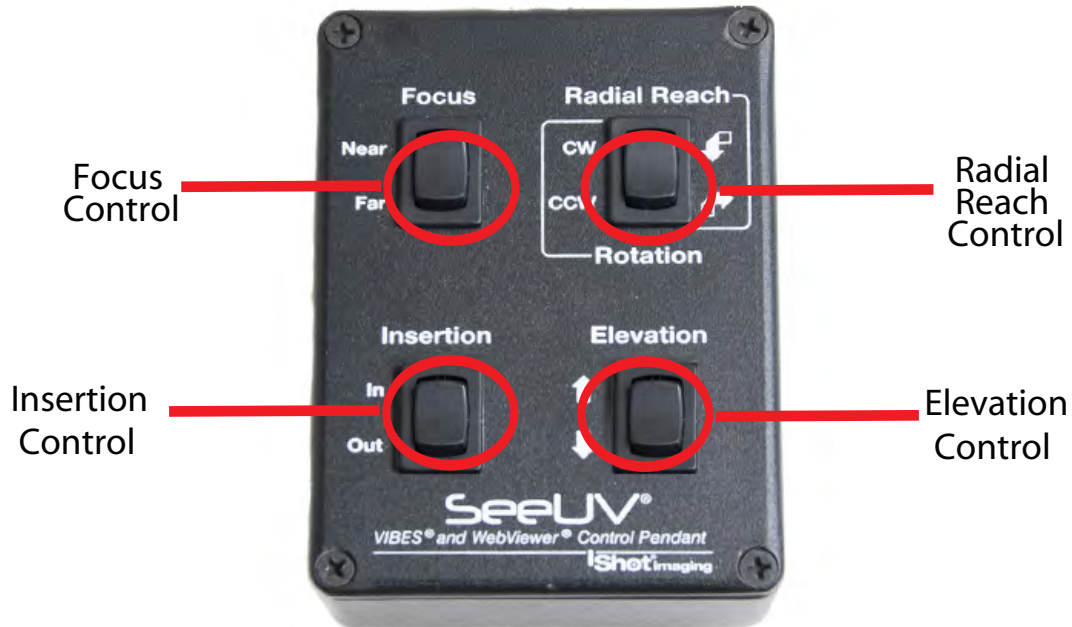

Pendant Controller - Figure 12

Refer to Figure 12

Pendant Control Features	Control Function
FOCUS	Focus image on screen near and far
RADIAL REACH	Inserts/retracts WebViewer® Camera head
INSERTION	Motorized movement of WebViewer® Boom along x-axis
ELEVATION	Motorized movement of WebViewer® Boom along y-axis

6.0 Operation

**** 6.5 Part Rotation Fixture (Specifically for EM14838)****

The WebViewer is designed to inspect parts on an encoded, dual-rotating part fixture.

InterTest, Inc. is not responsible for injuries or damages. Load the part on to fixture using best practices in line with customers own part handling policies and procedures. Exercise due caution at all times – use care to protect yourself, the part and the system.

Once the part is on the Rotation Fixture, it can be rotated around its X-axis manually by hand (Figure 12). See section 6.3 for explanation on its encoder controls.

Fore and Aft Part Inspection

To rotate the part around its Y-axis, unlatch the locking pin mechanism (circled) and rotate manually by hand 180 degrees. Re-lock the fixture and continue inspection (Figure 12).

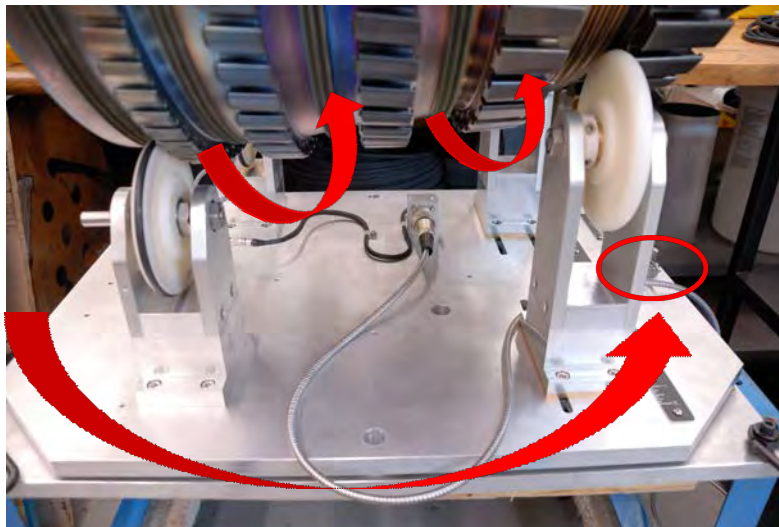

Figure 13

6.0 Operation

6.6 Encoder Controls (Refer to Figure 9)

The WebViewer® is designed to display a total of six (8) encoded values to the monitor. There are two (2) values each for Insertion, Radial Reach, Elevation and Part Rotation.

Starting Value:

It is recommended that you use the encoded value 1 as your starting point value. Reset this value just prior to entry into the component. Use value 2 to mark and measure any detected flaws once inside.

Resetting Values:

All encoder values can be reset quickly and simply by pressing the rocker switch on the Control Box that corresponds to the value desired.

Note: Avoid resetting value 1 once inside the component if you are using this as your start value.

Encoder Control Features	Encoder Functions
ROTATION/RADIAL REACH	Press UP on "1" to set first encoded value. Press DOWN on "2" to set second encoded value
INSERTION	Press UP on "1" to set first encoded value. Press DOWN on "2" to set second encoded value
ELEVATION	Press UP on "1" to set first encoded value. Press DOWN on "2" to set second encoded value
PART ROTATION	

6.7 On-Screen Display Options

Switches located on the rear panel of the Control Unit (Figure 10):

On-Screen Display Features	On-Screen Display Functions
OSD	Toggles ON/OFF the On-Screen Display
BACKGROUND	Toggles between transparent text background and black box background
SCREEN POSITION	Toggles On-Screen Display into 4 different screen quadrants
UNITS	Toggles between inches and centimeters

7.0 Care & Maintenance

7.1 Overall System Care & Maintenance

- Do not expose to moisture or direct sunlight.
- Do not expose positioning mechanism to abrasive particulates or environments with airborne debris.
- Always replace blown fuses with identical fuses, rated correctly.
- Never bypass the grounding circuits of system components.
- Bundle all excess cordage to prevent snagging
- Move cart with care. Abrupt stops, excessive forces, and uneven surfaces may cause the cart to turn over, damage the system or possibly injure personnel.
- Do not operate near intense electromagnetic fields.
- With the exception of lamp and fuse replacements, refer all service to InterTest technicians.
- Always retract boom before moving cart.
- Do not subject to loads.
- Do not jar.
- Ensure attachment is properly positioned to prevent damage.
- Do not move cart while WebViewer camera is deployed.
- Contact InterTest immediately if you experience problems with camera head or control box use.

7.2 Symbol Reference



Operation & Service Manual



Warning: Heat Source

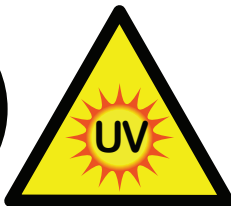

Warning: Ultra-Violet Light



Warning: Moving Parts



Warning: Electrical Hazard

8.0 Safety

Boom Hazard

- Use care when moving the WebViewer. Boom protrudes well past the end of the cart.

Light Sources & Light Guides

- Do not look directly at UV light, damage to your eyes may occur.

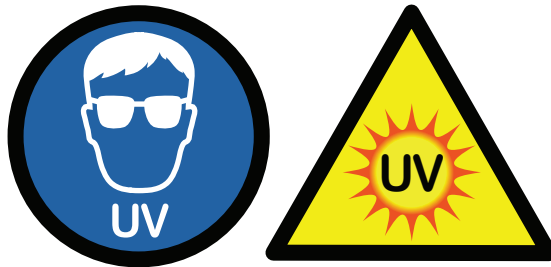

- Use care when removing light guides from light sources after use, they will be very hot.



- Never put anything into the light guide connections on the light source but a light guide with the correct adapter.

Moving Components

- The WebViewer contains moving parts. Please keep clear of all moving areas and components to prevent injury.



9.0 Specifications & Declarations of Conformance

System Specification for SeeUV VIBES-WV-ME / Webviewer: Motorized and Encoded*

Complete System Specifications:

- 300 kg gross weight
- Do Not Lift

Camera Sensor Specification:

- ¼ inch interline transfer CCD color imager
- NTSC video format
- 768H x 494V effective pixels
- Resolution > 470 TV lines
- Automatic white balance
- Capable of resolving a 0.10 mm (.004") UV fluorescence indication

Illumination System Specifications:

- Utilizes Main VIBES Light Sources:
 - EM14465 USHIO UV Light Source and EM18404 LED-35 White Light Source
- 3.5-meter light guide for UV transmission, 3mm active area
- 3.5-meter light guide for white light transmission, 2mm active area
- UV light peak output at 365nm
- White light cut filter at 390 nm for UV operation
- UV intensity greater than 2000 $\mu\text{W}/\text{cm}^2$ at 3 inch viewing distance
- White and UV light has full range variable intensity; simultaneous and independent operations

Camera Head Features:

- 11.1 mm x 31.8 mm x 76.2 mm (.438" x 1.25" x 3.00") head dimensions
- Motorized remote control of focus
- Optical adapters that change direction of view: 0°, 60° AFT, 90° AFT (comes standards with system) and 60° FWD, 90° FWD (optional)

Optical Adapters Specifications:

(All capable of seeing .25 mm (.010") TAM 135273 target at noted distance)

- 0° DIRECT view adapter:
 - 4 mm lens
 - 51° x 39° field of view (horizontal x vertical)
 - Field of View measurement: 18 x 25 mm (.71" x .98") at a 25 mm (.98") distance from viewing port
 - Viewing Resolution: .05 mm (.002") indication at a 25 mm (.98") distance

**Motorized Insertion and Elevation are optional*

9.0 Specifications & Declarations of Conformance

- 60° AFT view adapter:
 - 8 mm lens
 - 26° x 19° field of view (horizontal x vertical)
 - Field of View: 18 x 25 mm (.71" x .98") at a 25 mm (.98") distance from viewing port
 - Viewing Resolution: .05 mm (.002") indication at a 50 mm (1.97") distance

- 90° AFT view adapter:
 - 3.2 mm lens
 - 74° x 58° field of view (horizontal x vertical)
 - Field of View: 30 x 40 mm (1.2" x 1.6") at a 25 mm (.98") distance from viewing port
 - Viewing Resolution: .10 mm (.004") indication at a 25 mm (.98") distance

- 60° FORWARD view adapter:
 - 8 mm lens
 - 26° x 19° field of view (horizontal x vertical)
 - Field of View: 18 x 25 mm (.71" x .98") at a 50 mm (2.0") distance from viewing port
 - Viewing Resolution: .05 mm (.002") indication at 50 mm (1.97") distance

- 90° FORWARD view adapter:
 - 3.2 mm lens
 - 74° x 58° field of view (horizontal x vertical)
 - Field of View: 30 x 40 mm (1.2" x 1.6") at a 25 mm (.98") distance from viewing port
 - Viewing Resolution: .10 mm (.004") indication at a 25 mm (.98") distance

Delivery System Specifications:

- Movement in radial reach direction (insertion and retraction)
- Motorized and Encoded radial reach position
- Overall reach 254 mm (10.0")
- Airborne Noise does not exceed 70 dB(A)

Control Unit Features:

- Radial Reach controls with on-screen, encoded radial reach position
- Focus Motor control
- Image Flip (to compensate while using the 90° AFT and 90° FWD optical adapters)
- Zero resets for encoded position values

9.0 Specifications & Declarations of Conformance

EC DECLARATION OF CONFORMITY
EU DECLARATION OF CONFORMITY



InterTest, Inc.
303 State Route 94
Columbia, NJ 07832
USA

Name and address of the company established in European Community and authorized to compile the Technical File:

ACC - Services Contact
105 route des pommiers
Centre Ubidoca
74370 St Martin Bellevue
FRANCE

InterTest, Inc. declares under our sole responsibility that the product described as:

Equipment Name: iShot See UV Free Standing WebViewer
Model /Type: EM14838
Serial number(s): SO53569

Complies with the requirements of the following European Directives:

Machinery Directive 2006/42/EC;
Electromagnetic Compatibility Directive 2014/30/EU.

Main standards considered:

EN ISO 12100:2010,
EN 60204-1:2018 + A1:2009
EN 61000-6-2:2019,
EN 61000-6-4:2007 + A1:2011

Date: 3 April 2019 At: InterTest, Inc., 303 State Route 94, Columbia, NJ 07832, USA

Name of authorized company representative: William J. Habermann

Signature:

A handwritten signature in black ink that reads "William J. Habermann".

9.0 Specifications & Declarations of Conformance



EU DECLARATION OF CONFORMITY

Product **ULB-35i, ULB-35p, ULB-35ndt, ULB-35rvi**

Manufacturer's name Ushio America Inc. Oregon Operations Division
Business Address Ushio America Inc. 5440 Cerritos Ave., Cypress, CA 90630

This declaration of Conformity is issued under the sole responsibility of the manufacturer.

Object of declaration **Model Number (not sensitive to spaces, dashes, suffix or case):** ULB-35i, ULB-35p, ULB-35ndt, ULB-35rvi
Model Description: Midori LED Light Source, Fiber Optic Illuminator,

The object of the declaration described above is in conformity with the relevant Union harmonization Legislation:

2011/65/EU
2014/30/EU
2014/35/EU

Reference to the relevant harmonizes standards used or references to other technical specifications in relation to which the conformity is declared:

EN/IEC 61010-1: 2010
EN / 61326-1: 2006 /IEC 61326-1: 2012
UL61010-1: 2012
IEC 62471- 2006
EN50581

Additional Information: Safety Test Report Number: Intertek 101301344 LAX-001 Safety Test (UL) Report Number: Intertek 101301344 LAX-002 EMC Test Report Number: Intertek 101301344 LAX-005 Photobiological Report number: Intertek 101301344 LAX-004 Technical File: Maintained by Ushio America Inc. TF-010

Signed for and on behalf of: Ushio America Inc.

Place and date of issue: Cypress, CA, USA
May 25, 2017

Name, Function: Vinay Prakash Q.C.
Manager



Signature:



DECLARATION OF CONFORMITY

SeeEyes Co., LTD

#503 ~ 509, 555 Dunchondaero, Jungwon-gu, Sunghnam-city, Gyunggi-do, Korea
declare under our sole responsibility that the product;

Product : IP Multi-Format Test Monitor
Model : SC-IPM07HD

to which this declaration relates is in conformity with the following standards or
other normative documents;

EN 55032:2012/AC:2013(Class A)

EN 61000-3-2: 2014

EN 61000-3-3: 2013

EN 50130-4: 2011

following the provisions of Directives;

2014/30/EU Electromagnetic Compatibility Directive

Oct 10, 2017
(Date of issue)

Choi Hae Yong
(Name)

H. y. Choi
(Signature)

9.0 Specifications & Declarations of Conformance

Equipment Label



InterTest Inc

303 Rt. 94 Columbia, NJ 07832 U.S.A.

Phone: +1 (908) 496-8008 www.intertest.com

Date of Mfg: March 2019

Equipment Name: iShot SeeUV

Free Standing

Webviewer

Model / Type: EM14838

Serial #: SO57967

220 VAC 50/60 Hz

10 AMPS



10.0 Service Records

Product: Free Standing WebViewer on Cart

EM Number: EM14838

Serial Number: SO57967

Date of Purchase: _____

Date	Service Performed
<u> / /</u>	_____

<u> / /</u>	_____

<u> / /</u>	_____

<u> / /</u>	_____

_____	_____

ELMO

Camera Control Unit Operation Manual

**MODEL
CC431E**

Thank you for purchasing the ELMO camera control unit CC431E. To use the camera properly, carefully read this operation manual before use. After reading the manual, we suggest you keep it in a convenient place for quick reference.

COMPONENTS

- (1) Camera control unit (CCU)
- (2) Accessory: Operation manual

NOTE: Camera head, Lens, AC/DC adapter, camera cable and video cable are option.

INFORMATION

This equipment has been tested and found to comply with the limits for a Class A digital device, pursuant to Part 15 of the FCC Rules. These limits are designed to provide reasonable protection against harmful interference when the equipment is operated in a commercial environment. This equipment generates, uses and can radiate radio frequency energy and, if not installed and used in accordance with the instruction manual, may cause harmful interference to radio communications.

Operation of this equipment in a residential area is likely to cause harmful interference in which case the user will be required to correct the interference at his own expense.

USER-INSTALLER CAUTION: Your authority to operate this FCC verified equipment could be voided if you make changes or modifications not expressly approved by the party responsible for compliance to Part 15 of the FCC rules.



This Class A digital apparatus complies with Canadian ICES-003.

Cet appareil numérique de la classe A est conforme à la norme NMB-003 du Canada.

SAFETY PRECAUTIONS

Read the following safety precautions carefully before using this product. These instructions contain valuable information on safe and proper use that will prevent harm and damage to the operator and other persons. Make sure that you fully understand the following details (indications, graphic symbols) before proceeding to the remaining sections in this manual.

Indication definitions



Indication	Meaning
 Warning	This indicates the existence of a hazard that death or catastrophic bodily injury* ¹ may result from improper use.
 Caution	This indicates the existence of a hazard that bodily injury* ² or property damage* ³ may result from improper use.

*1: Catastrophic bodily injury means loss of eyesight, burns (high and low temperature), shock, fracture, poisoning, etc. which leaves a sequela and require hospitalization or prolonged treatment.

*2: Bodily injury means injuries, burns and electric shock which does not require hospitalization or prolonged treatment.

*3: Property damage means extended harm to home, household effects, domesticated animals, and pets.

Graphic symbol definitions

Symbol	Meaning
	"⊘" indicates a prohibited action that must not be carried out. The actual prohibited action is indicated in the symbol or nearby graphically or described in text.
	"●" indicates a mandatory action that must be carried out. The actual instruction is indicated in the symbol or nearby graphically or described in text.

⚠ Warning



- **Stop operation immediately when any abnormality or defect occurs.**
Use during an abnormal condition; such as emitting smoke, burning odors, damage from dropping invasion of foreign objects, etc. may cause fire and/or electric shock. Be always sure to disconnect the power plug from the electrical outlet (socket) at once and contact your dealer.



- **Avoid installing in a shower room or a bathroom.**
This may cause fire and/or electric shock.



- **Do not operate in places with possibility of becoming wet.**
This may cause fire and/or electric shock.



- **Do not repair, disassemble and/or modify by yourself.**
This may cause fire and/or electric shock. Be always sure to contact your dealer for internal repair, check and cleaning of the product.



- **Use the specified power supply.**
Otherwise, a fire or an electric shock may occur.



- **Don't place things or materials on the unit.**
Ingress of foreign materials such as metallic things and liquid into the unit may cause a fire or an electric shock.



- **Do not put the product in an unstable, slanting and/or vibrated place.**
Drop and/or fail of the product may cause injury.



- **Do not touch the power cord or other connection cables during a thunderstorm.**
This might cause electric shock.

Caution



- **Note the following instructions when installing.**
 - Do not put an inflammable material on the product.
 - Do not put the product on an Inflammable material such as carpet or blanket.
 - Do not block a vent hole.
 - Do not put the product in a narrow space, since the heat generated from the product may be difficult to emanate.If you do not follow the above, the heat generated by the product may cause fire.



- **Do not put the product in direct sunshine and/or high temperature.**
The temperature inside the product may cause fire.



- **Avoid setting in humid, smoky, vaporized or dusty places. A fire or an electric shock may occur in such places.**
This may cause fire and/or electric shock.



- **Do not point the lens directly at the sun and/or intensive light such as direct sunlight, etc.**
Focusing of the light may cause injury of eye and/or fire.



- **Do not put the product in your mouth or swallow any parts.**
This may cause suffocation and/or injury.



- **Ask your dealer to perform a periodical check and internal cleaning (approx. once every five years).**
Dust inside the product may cause fire and/or trouble. For check and cleaning cost, please consult your dealer.

Disclaimer

We disclaim any responsibility and shall be held harmless for any damages or losses incurred by the user in any of the following cases:

1. Fire, earthquake or any other act of God; acts by third parties; misuse by the user, whether intentional or accidental; use under extreme operating conditions.
2. Malfunction or non-function resulting in indirect, additional or consequential damages, including but not limited to loss of expected income and suspension of business activities.
3. Incorrect use not in compliance with instructions in this instruction manual.
4. Malfunctions resulting from misconnection to other equipment.
5. Repairs or modifications made by the user or caused to be made by the user and carried out by an unauthorized third party.
6. Notwithstanding the foregoing, ELMO's liabilities shall not, in any circumstances, exceed the purchase price of the product.

Copyright and Right of Portrait

There may be a conflict with the Copyright Law and other laws when a customer uses, displays, distributes, or exhibits an image picked up by a television camera without permission from the copyright holder. Please also note that transfer of an image or file covered by copyright is restricted to use within the scope permitted by the Copyright Law.

PART NAMES AND FUNCTIONS

Camera Control Unit (CCU)

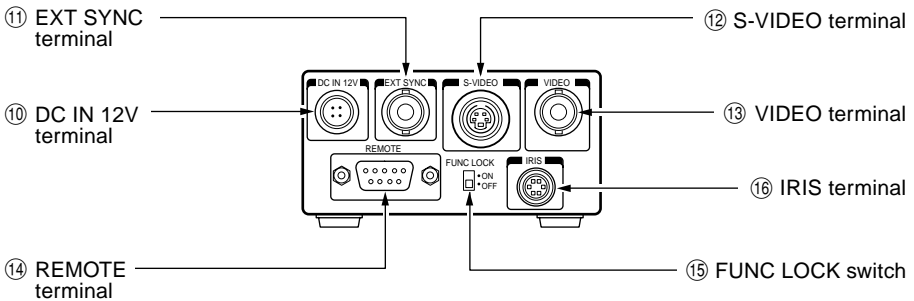
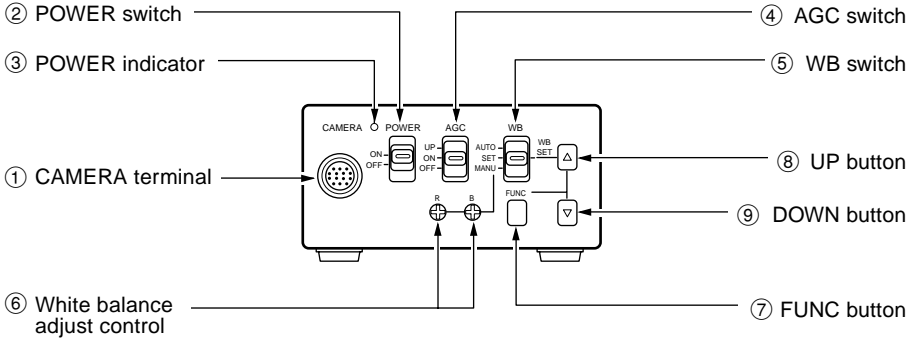

① CAMERA terminal	Connects to the camera head.
② POWER switch	Turns on and off the camera control unit.
③ POWER indicator	Lights up when the power is turned on.
④ AGC switch	Selects the gain mode. (AGC OFF/AGC ON/SENS UP)
⑤ WB switch	Selects the white balance mode. (MANU/SET/AUTO)
⑥ White balance adjust control	Adjusts the R gain and B gain with the white balance mode set to MANU by the WB switch ⑤.
⑦ FUNC button	Determines the setting indication contents when the setting menu is displayed on the screen.
⑧ UP button	Selects the setting item when the setting menu is displayed on the screen. (When the WB switch ⑤ is set to SET, pressing the UP button for more than 2 sec. activates the white balance SET operation.)
⑨ DOWN button	Selects the setting item when the setting menu is displayed on the screen.
⑩ DC IN 12V terminal	Accepts a DC power supply (12V).
⑪ EXT SYNC terminal	Accepts an external sync signal to synchronize the camera output signal with external signal.
⑫ S-VIDEO terminal	Connects terminal to S input terminal of a monitor or a VCR, etc.
⑬ VIDEO terminal	Connects terminal to video input terminal of a monitor or a VCR, etc. Used at the same time with the S-VIDEO terminal.
⑭ REMOTE terminal	Controls the functions with RS232C.
⑮ FUNC LOCK switch	Locks the switches and control on the front panel. When the FUNC LOCK switch is set to ON, all settings except for the POWER switch ② and the file item of the screen setting menu.
⑯ IRIS terminal	Connect when using an automatic iris lens (with CN43H/CN42H camera head).

CONNECTION

Example of Standard Connection

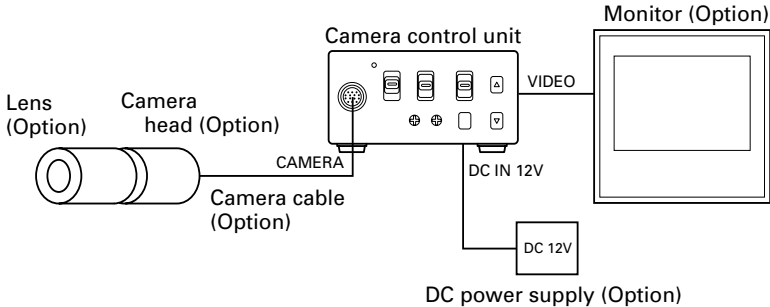

Cautions on Connection

- When connecting or disconnecting the camera cables (for the camera head and camera control unit), always turn off the power switch of the camera control unit first. If not, the camera head may be damaged.
 - When connecting the camera, always turn off the power of the camera control unit and any other equipment connected.
- ① Remove the camera head protection cover and mount a lens (option).
 - ② Connect the camera head and the camera control unit with the camera cable (option).
 - ③ Connect the VIDEO (or S-VIDEO) terminal of the camera control unit to a video input terminal of a monitor, etc.
 - ④ Connect a DC power supply (12V) to the DC IN 12V terminal of the camera control unit.
- For DC power supply connecting to DC IN 12V terminal, use UL listed and/or CSA approved ungrounding type AC adaptor with the specifications described below.

Power supply voltage:	DC12V \pm 0.5V
Current rating:	More than 800 mA
Ripple voltage:	Less than 50 mV(p-p)
Connector:	HR10A-7P-4S (Hirose)
	Pins 1, 2: e , Pins 3, 4: d

Connection on CCU Back Panel

The figure below shows the back panel connection terminals of the camera control unit.

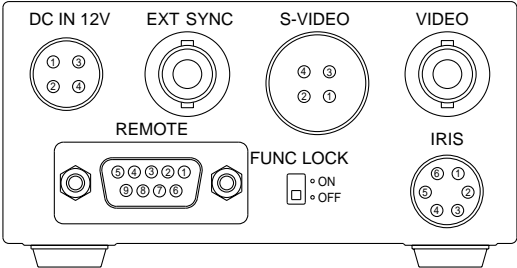

Connector Pin Assignments

DC IN 12V

1	+12V
2	+12V
3	GND
4	GND

S-VIDEO

1	GND
2	GND
3	Y
4	C

REMOTE

1	NC
2	TXD
3	RXD
4	DSR
5	GND
6	DTR
7	CTS
8	RTS
9	NC

IRIS

1	NC
2	VIDEO
3	GND
4	+12V
5	GND
6	NC

* When using the REMOTE terminal, please consult with your dealer.

- **Using the auto-iris lens**

The following table shows the IRIS terminal when using the auto-iris (EE) lens.

Table 1

IRIS Connector Terminal No.	Signal	Rated
1	—	
2	Video signal	0.8 ± 0.1Vp-p
3	GND	
4	Power (DC)	+ 12V (less than 50mA)
5	(GND)	
6	—	

The IRIS connector used for the IRIS terminal: HR10A-7P-6P of HIROSE ELECTRIC CO., LTD.

- **EE lens**

The IRIS extension cable (optional) is usable for the EE lens. Use the connector HR10A-7P-4P of HIROSE when the IRIS extension cable is selected. For connections, follow the instruction below.

When the IRIS extension cable is used under the right condition, the cable automatically converts to connection for the EE lens in Table 1.

EE lens connector HR10A-7P-4P
1. Power (+)
2. GND
3. Video signal
4. Unconnected or ground

Notes:

- **Current consumption must be 50 mA or less.**
- **Avoid an incorrect connection or short-circuit.**

USING CAMERA CONTROL IN FIXED POSITION

The camera control unit can be directly mounted by using M3 screws if the four rubber feet are removed on bottom of the control unit. When mounting directly as described above, do not use longer screws. If the screws enter by more than 5 mm from the control unit mounting surface, they will cause a short-circuit inside the control unit. For details of screw hole locations, refer to "PROFILE" of the camera control unit.

HOW TO USE THE CAMERA

Turn on the POWER switch on the camera control unit and adjust the lens iris and focus while observing a picture on the monitor screen. To obtain the best picture quality, perform various settings.

AGC (Automatic Gain Control)

AGC functions "OFF", "ON" or "UP" can be selected on the screen menu. Generally, the camera is used with the AGC set to OFF, but when increased camera sensitivity is required, it is set to ON. When more sensitivity is required, "UP" is selected. With the AGC ON, the camera sensitivity approximately doubles, and with the UP selected the sensitivity approximately doubles again, but noise will also increase. We recommend you increase intensity of the lighting to obtain good pictures.

The AGC measurement area is the same as that used for "AREA". Refer to "AREA (Measurement Area)".

White Balance

A white balance adjustment is necessary to obtain pictures with correct color tone. This camera allows you to select the white balance adjustment of "AUTO", "SET", and "MANU". With the AUTO mode selected, the camera adjusts the white balance automatically. Most of shooting will be made in the AUTO mode. The color temperature applicable to this camera is about 2500 to 7000K.

	AUTO	SET	MANU
Outline	Camera automatically measures object color temperature and adjusts the white balance.	Adjust white balance by pressing "UP" button on the camera control unit while shooting a white object.	Adjust R (red) and B (blue) levels on the control unit while shooting a white object.
Features	Automatically traces variations of color temperature and adjusts the white balance.	Measurement accuracy is higher than AUTO mode. This mode is effective when shooting under less variations of color temperature.	Measurement accuracy is higher than SET mode. This mode is effective for users desiring specific color temperature, also effective when shooting under least variations of color temperature.
Notes	Under poor illumination, white balance may not be corrected.		Adjustment will be made by viewing monitor or vector scope.

(1) White balance adjustment in modes other than AUTO

(1.1) White balance adjustment in SET mode

- ① Set the WB switch to “SET” position.
- ② Shoot a white object to fill entire screen and press the UP button (▲) for about 2 sec.
- ③ When the white balance adjustment completes, the letters “WB SET” blinking at the upper right of the screen changes to “WB OK” and then turns off. If the “WB NG” is displayed, it shows the white balance is out of the adjustment range. This is caused in the white object is not shot or the video level is set too high or too low even if the white object is shot. Shoot the white object or set the video level correctly.

Note:

- **With the screen menu displayed, the UP button is used for moving the cursor or modifying the data. To activate the SET mode by pressing the UP button, turn off the screen menu.**

(1.2) White balance adjustment in MANU mode

- ① Set the WB switch to “MANU” position.
- ② Shoot the white object and adjust the white balance by adjusting the white balance adjust controls “R” and “B” with the screwdriver while observing the monitor or vector scope.

FUNC (Function Lock)

The FUNC LOCK switch protects settings even if a switch is accidentally pressed after setting. When the FUNC LOCK switch is ON, only the following functions are available.

POWER switch (ON/OFF)

FILE (A/B) in menu

Settings will not be changed even if the other switches are operated. In the menu screen, all except FILE and END are displayed in black letters (white when the FUNC LOCK switch is OFF) and “FUNCTION LOCK ACTIVE” blinks to indicate that the FUNC LOCK switch is ON.

FILE	A
SHUTTER	AUTO
PEDESTAL	00
SYNC	INT
AREA	LINK:1
WB-OFFSET	00
INIT.	
END	
FUNCTION LOCK ACTIVE	
PUSH FUNC TO SELECT	

OPERATION OF SCREEN MENU

Setting while monitoring the menu on the monitor screen is possible. Following seven items can be set.

- ① Scene file
- ② Electronic shutter (AUTO/MANUAL), backlight correction
- ③ Pedestal level
- ④ Phase matching in external synchronization (horizontal/subcarrier synchronization)
- ⑤ White balance, auto electronic shutter, AGC measurement area
- ⑥ White balance offset
- ⑦ Scene file factory setting

Press the FUNC button to display the menu. The menu appears as shown on the right. Current setting is displayed. Move the cursor up or down using the UP and DOWN buttons, and set an item by pressing the FUNC button. To quit the menu, move the cursor to END and press the FUNC button.

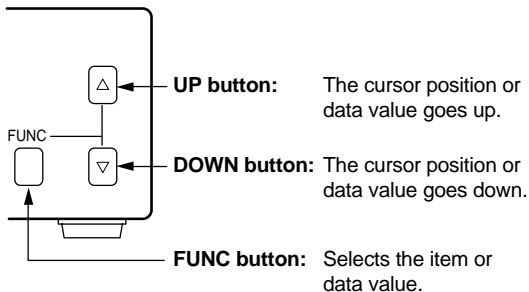

Main Menu

FILE	A
SHUTTER	AUTO
PEDESTAL	00
SYNC	INT
AREA	LINK:1
WB-OFFSET	00
INIT.	
END	
PUSH FUNC TO SELECT	

Notes:

- **When setting is changed in the menu screen, be sure to move the cursor to "END" and press the FUNC button to clear the menu. New setting is stored in the camera.**
- **Don't turn off the POWER switch before clearing the menu. New setting is not stored, and old data remains.**

FILE (Screen File)

There are two scene files A and B which can be selected according to the shooting state.

- ① Move the cursor to "FILE" in the main menu using the UP or DOWN button.
- ② Press the FUNC button to display the contents to set FILE, A or B. Move the cursor to A or B using the UP or DOWN button. Press the FUNC button to set the contents.

Note:

- **The scene file is for the menu screen. The AGC switch and the WB switch are valid in their set positions.**

```

FILE          A
SHUTTER      AUTO
PEDESTAL     00
SYNC         INT
AREA         LINK:1
WB-OFFSET    00

INIT.
END

PUSH [FUNC] TO SELECT
    
```

```

FILE          A
SHUTTER      [B]
PEDESTAL     00
SYNC         INT
AREA         LINK:1
WB-OFFSET    00

INIT.
END

PUSH [FUNC] TO SELECT
    
```

SHUTTER (Electronic Shutter, Backlight Control)

The electronic shutter is available in AUTO (auto electronic shutter), 1/60 ~ 1/10000 and SS (synchronized scan).

AUTO: Controls electronic shutter automatically to get the set video level. Can be selected in backlight correction, peak measurement, average measurement and measurement area.

1/60~1/10000: Exposure time can be fixed to any one of 1/60, 1/100, 1/250, 1/500, 1/1000, 1/2000, 1/4000 and 1/10000.

SS: Sets the electronic shutter in horizontal scanning time (1H).

- ① Move the cursor to "SHUTTER" in the main menu using the UP or DOWN button.
- ② Press the FUNC button to display AUTO ~ EXIT to set SHUTTER. Move the cursor to a desired item of AUTO ~ SS using the UP or DOWN button. Press the FUNC button to frame a desired item in white.
- ③ Move the cursor to "EXIT" using the UP or DOWN button. Press the FUNC button. Return to the main menu.

```

FILE          A
[SHUTTER]    AUTO
PEDESTAL     00
SYNC         INT
AREA         LINK:1
WB-OFFSET    00

INIT.
END

PUSH [FUNC] TO SELECT
    
```

```

                [AUTO]
FILE          1/60
[SHUTTER]    1/100
PEDESTAL     1/250
SYNC         1/500
AREA         1/1000
WB-OFFSET    1/2000
                1/4000
INIT.        1/10000
END          SS 262/525H
                EXIT
PUSH [FUNC] TO SUB MENU
    
```

(1) Detail setting in AUTO mode (Auto Electronic Shutter)

When the FUNC button is pressed after AUTO is selected, the submenu for SHUTTER:AUTO appears. Set details in this screen.

LEVEL: Adjust the auto electronic shutter video level. Larger values indicates brighter level, and vice versa. Data can be set in a range of -30 to +30.

BLC: Correction for backlight. This can be set when the measurement area is set to one of "1/2", "1/8" and "SLIT" for AREA in the main menu. Backlight is corrected at ON, but not at OFF. When the measurement area is "1", BLC is displayed in black letters and setting is impossible.

PEAK:AVE: Selects peak or average for measurement of auto electronic shutter video level. The peak to average ratio can be changed in a range of 00:10 to 10:00.

Note:

- **While BLC is ON, PEAK:AVE is displayed in black letters and setting is impossible.**

- ① Move the cursor to a desired item (LEVEL, BLC, PEAK:AVE) using the UP or DOWN button. Press the FUNC button. The cursor moves to the data of the selected item. Set the data by pressing the UP or DOWN button.
- ② After setting the data, press the FUNC button. The cursor moves to the item. To finish setting of submenu, move the cursor to "EXIT" and press the FUNC button to return to "SHUTTER" in the main menu.

	AUTO
FILE	1/60
SHUTTER	1/100
PEDESTAL	1/250
SYNC	1/500
AREA	1/1000
WB-OFFSET	1/2000
	1/4000
INIT.	1/10000
END	SS 262/525H
	EXIT
PUSH FUNC TO SUB MENU	

SHUTTER: AUTO	SUB MENU
LEVEL	00
BLC	OFF
PEAK:AVE	00:10
	EXIT
PUSH FUNC TO SELECT	

SHUTTER: AUTO	SUB MENU
LEVEL	00
BLC	
PEAK:AVE	
	EXIT
PUSH FUNC TO SELECT	

Example of display for LEVEL

(2) SS (Synchronized Scan)

- ① Move the cursor to "SS" using the UP or DOWN button. Press the FUNC button. (SS is set.)
- ② Press the FUNC button. The cursor moves to the data and blinks. The data varies in 1/525H to 262/525H when the UP or DOWN button is pressed. Set a desired data, and press the FUNC button.
- ③ Return to "SS" of SHUTTER.

	AUTO
FILE	1/60
SHUTTER	1/100
PEDESTAL	1/250
SYNC	1/500
AREA	1/1000
WB-OFFSET	1/2000
	1/4000
INIT.	1/10000
END	SS 262/525H
	EXIT
PUSH FUNC TO SELECT	

PEDESTAL (Pedestal Level)

- ① Move the cursor to PEDESTAL using the UP or DOWN button.
- ② Press the FUNC button. The cursor moves to the data. Set the data using the UP or DOWN button. The data can be set in a range of -50 to +50. After setting the data, press the FUNC button to return to the main menu.

```
FILE          A
SHUTTER       AUTO
PEDESTAL     00
SYNC          INT
AREA          LINK:1
WB-OFFSET    00

INIT.
END

PUSH FUNC TO SELECT
```

```
FILE
SHUTTER
PEDESTAL     00
SYNC
AREA
WB-OFFSET

INIT.
END

PUSH FUNC TO SELECT
```

SYNC (Setting for External Sync)

This adjusts horizontal phase and subcarrier phase while externally synchronized. INT is displayed for internal synchronization and changed automatically to EXT when the external synchronizing signal is entered.

- ① Move the cursor to "SYNC" using the UP or DOWN button.
- ② Press the FUNC button to display the available items (H-PHS, SC-PHS, SC-FINE).

H-PHS: H (horizontal) phase matching 0 ~ 99

SC-PHS: SC (subcarrier) rough adjustment 0, 90, 180, 270

SC-FINE: SC (subcarrier) fine adjustment 0 ~ 99

```
FILE          A
SHUTTER       AUTO
PEDESTAL     00
SYNC         INT
AREA          LINK:1
WB-OFFSET    00

INIT.
END

PUSH FUNC TO SELECT
```

```
FILE          A
SHUTTER       AUTO
PEDESTAL     00
SYNC         EXT.VBS
AREA          LINK:1
WB-OFFSET    00

INIT.
END

PUSH FUNC TO SELECT
```

- ③ Move the cursor to a desired item (H-PHS, SC-PHS, SC-FINE) using the UP or DOWN button. Press the FUNC button and the data is displayed. Set the data using the UP or DOWN button and press the FUNC button to select the data. To return to the main menu, move the cursor to EXIT and press the FUNC button.

Note:

- **If the internal synchronization is set while the SYNC item (H-PHS, SC-PHS, SC-FINE) is being displayed, the display automatically turns to INT disabling setting.**

```

FILE
SHUTTER
PEDESTAL
[SYNC]      [H-PHS]  50
AREA        SC-PHS  0
WB-OFFSET   SC-FINE 50
EXIT

INIT.
END

PUSH [FUNC] TO SELECT

```

AREA (Measurement Area)

AREA is a measurement AREA item for AGC, auto electronic shutter and white balance. The AREA setting for AGC and auto electronic shutter are the same, so each setting can not be made separately. However, the AREA setting for white balance can be made separately depending on the AREA setting for AGC and auto electronic shutter.

- ① Move the cursor to AREA using the UP or DOWN button.
- ② Press the FUNC button to display the available items (LINK, SEP).
- ③ Move the cursor to a desired item (LINK, SEP) using the UP or DOWN button.

```

FILE      A
SHUTTER   AUTO
PEDESTAL  00
SYNC      INT
[AREA]    LINK:1
WB-OFFSET 00

INIT.
END

PUSH [FUNC] TO SELECT

```

(1) Setting AREA the same for AGC, auto electronic shutter and white balance

- ① Move the cursor to LINK using the UP or DOWN button.

```

FILE
SHUTTER
PEDESTAL
SYNC
[AREA]    [LINK]:1
WB-OFFSET SEP
EXIT

INIT.
END

PUSH [FUNC] TO SELECT

```

- ② Press the FUNC button to display data 1 ~ SLIT for LINK. Move the cursor to a desired item of AREA data (1, 1/2, 1/8, SLIT) using the UP or DOWN button.
- ③ Press the FUNC button to set the data.

```

FILE
SHUTTER
PEDESTAL
SYNC
AREA LINK 1
WB-OFFSET SEP 1/2
EXIT 1/8

INIT. SLIT
END

PUSH FUNC TO SELECT

```

(2) Setting AREA for white balance separately from the AREA setting for AGC and auto electronic shutter

- ① Move the cursor to SEP using the UP or DOWN button, and press the FUNC button. SEP is selected and framed in white.
- ② Press the FUNC button to display the submenu.
- ③ Move the cursor to a desired item using UP or DOWN button.

WB: Measurement AREA for white balance
1, 1/2, 1/8, SLIT
Valid when the WB switch is AUTO and/or SET.

SHUTTER: Measurement AREA for auto electronic shutter and AGC
1, 1/2, 1/8, SLIT

- ④ Press the FUNC button to select a desired item. The setting data (1, 1/2, 1/8, SLIT) is displayed. Move the cursor to a desired item using UP or DOWN button, then press the FUNC button to select the data.
- ⑤ The submenu for AREA appears. Move the cursor to EXIT, and press the FUNC button to return to the main menu.

```

FILE
SHUTTER
PEDESTAL
SYNC
AREA LINK:1
WB-OFFSET SEP
EXIT

INIT.
END

PUSH FUNC TO SELECT

```

```

AREA SEP SUB MENU

WB 1
SHUTTER 1
EXIT

PUSH FUNC TO SELECT

```

The size of AREA is approximately as shown below.

(1) 1 (Whole monitor screen)



(2) 1/2

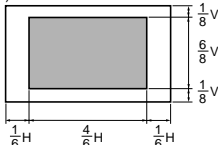

(3) 1/8

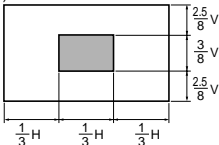

(4) SLIT

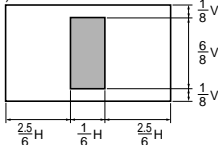

```

AREA SEP SUB MENU

WB 1
SHUTTER 1/2
EXIT 1/8
SLIT

PUSH FUNC TO SELECT

```

WB-OFFSET (White Balance Offset)

This offsets the focusing point of white balance in the direction of orange or cyan when the WB switch is set to "SET".

- ① Move the cursor to WB-OFFSET using the UP or DOWN button.
- ② Press the FUNC button. The cursor moves to the data item.
- ③ Change the data using the UP or DOWN button.
 - +20 ~ -20
 - + Orange direction
 - Cyan direction

Press the FUNC button at a desired data value to set the data.

```
FILE          A
SHUTTER       AUTO
PEDESTAL     00
SYNC         INT
AREA         LINK:1
WB-OFFSET    00
```

```
INIT.
END
```

```
PUSH [FUNC] TO SELECT
```

```
FILE
SHUTTER
PEDESTAL
SYNC
AREA
WB-OFFSET    00
```

```
INIT.
END
```

```
PUSH [FUNC] TO SELECT
```

INIT. (Scene File Initialization)

This reset settings of the scene file to the factory setting.

- ① Select a scene file (A or B) to initialize the setting in FILE.
- ② Move the cursor to INIT. using the UP or DOWN button.
- ③ Press the FUNC button. The selected scene file (A or B) is displayed. NO/YES is displayed.
- ④ Select NO when not initializing. Select YES and press the FUNC button when initializing.

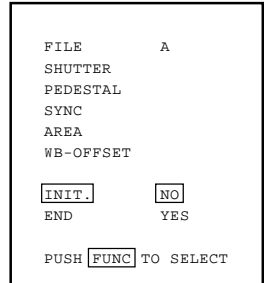
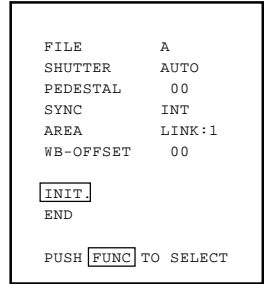

Factory setting (the following setting if INIT. is executed)
 The setting is common to scene files A and B.

```

SHUTTER  AUTO
PEDESTAL 00
SYNC     EXT.VBS
AREA     LINK:1
WB-OFFSET 00

              ( SEP WB 1 )
              ( SHUTTER 1 )

              H-PHS 50
              SC-PHS 0
              SC-FINE 50

              LEVEL 00
              BLC OFF
              PEAK:AVE 00:10
    
```

END (End of Screen Display)

To finish the menu, move the cursor to END using the UP or DOWN button and press the FUNC button. To store the setting in the camera, be sure to clear the display by END item. When the display is cleared, the setting is stored in the camera. If the POWER switch is turned off while the menu is being displayed, the setting is not stored and the old data remains.

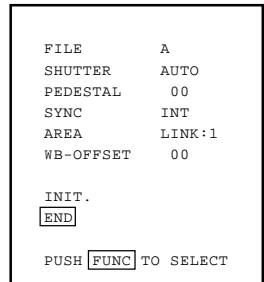

EXTERNAL SYNC

When using the camera with an external sync, connect a composite video signal (C-VIDEO) to the EXT SYNC terminal on back of the camera control unit. When the camera accepts external sync, it is automatically switched from the internal sync to the external sync.

(1) External sync signal input conditions

C-VIDEO	:	SYNC section	$0.3 \pm 0.1V$
(75Ω unbalanced)		BURST section	$0.3 \pm 0.1V$

(2) External sync frequency range

Within ± 50 ppm referred to NTSC standard frequency
(H frequency 15733.5 Hz to 15735.0 Hz)

(3) Using the camera with external sync signal

When using more than two cameras in external synchronization, this adjustment allows matching of picture tone between two cameras. Adjust H (horizontal) phase and SC (sub carrier) phase if necessary.

(3.1) H (horizontal) phase adjustment

Observe the external sync signal and video output signal on the camera with a dual trace oscilloscope, and adjust "H-PHS" of "SYNC" on the screen menu so that the H phase matches.

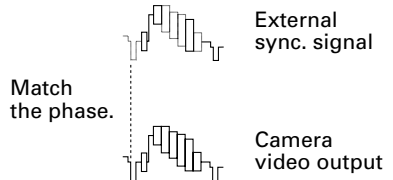

(3.2) SC (sub carrier) phase adjustment

Perform a coarse adjustment for 0, 90, 180, or 270 degrees in "SC-PHS" on the screen menu and then perform a fine adjustment with "SC-FINE". Using a vector scope for the phase adjustment will provide more accuracy.

CAUTIONS ON USE AND INSTALLATION

- **Carefully handle the units.**

Do not drop, or give a strong shock or vibration to the camera. This may cause problems. Treat the camera cables carefully to prevent cable problems, such as cable breakdown and loosened connections.

- **Do not shoot intense light.**

If there is an intense light at a location on the screen such as a spot light, a blooming and smearing may occur. When intense light enters, vertical stripes may appear on the screen. This is not a malfunction. Ghosts may occur when there is an intense light near the object. In this case, change the shooting angle.

- **Install the camera in a location free from noise.**

If the camera or the cables are located near power utility lines or a TV, etc. undesirable noise may appear on the screen. In such a case, try to change the location of the camera or the cable wiring.

- **Moire**

When thin stripe patterns are shot, stripe patterns that are not actually there (moire) may appear as interference stripes. This is not a malfunction.

- **Operating ambient temperature and humidity.**

Do not use the camera in places where temperature and humidity exceed the specifications. Picture quality will lower and internal parts may be damaged.

Be particularly careful when using in places exposed to direct sunlight. When shooting in hot places, depending on the conditions of the object and the camera (for example when the gain is increased), noise in the form of vertical strips or white dots may occur. This is not a malfunction.

- **Handling of the protection cap.**

Keep the protection cap away from children. Children may put them into mouth or swallow them accidentally. The protection cap protects the image sensing plane when the lens is removed from the camera, do not throw away.

- **When not using the camera for a long-time.**

Stop supplying power.

- **When cleaning the camera**

Always turn off the power and clean with a piece of soft dry cloth. Do not use benzene, alcohol, thinner, household detergents, chemically treated cloths, etc. If used, coating and printed letters may be discolored. When cleaning the lens, use a lens cleaning paper, etc.

- **Avoid using or storing the camera in the following places:**

Places filled with highly flammable gas.

Places near gasoline, benzene, or paint thinner.

Places subject to strong vibration.

Places contacting chemicals (such as pesticides), rubber or vinyl products for a long period of time.

TROUBLESHOOTING CHART

Symptom	Items to be checked
No picture	<ul style="list-style-type: none"> • Is the power supplied correctly? • Is the lens iris adjusted correctly? • Are the cables connected correctly?
Poor color	<ul style="list-style-type: none"> • Is the monitor (TV) adjusted correctly? • Is the white balance of the camera adjusted correctly? (in modes other than automatic trace) • Is the illumination dark? • Is the SC phase adjusted correctly? (External sync)
"HEAD UNCONNECTED" or "CABLE DETECT ERR" is displayed on the screen	<ul style="list-style-type: none"> • Turn the power of the camera off, make proper connection for the camera head, camera cable, and camera control unit, and then turn the power on again. (Improper connection may cause the trouble.)

OPTIONAL PARTS

Camera head

Type	Code #	
MN43H	9742-9	φ 17mm Micro camera head
QN42H	9657	φ 7 mm Super-micro camera head
QN42HL	9657-9	φ 7 mm Super-micro camera head
CN43H	9743-9	C-mount camera head
UN43H	9744-9	φ 12 mm Micro camera head

Camera cable (for MN43H, CN43H, UN43H, MN42H and CN42H)

Type	Code #	Nominal length	Diameter
EMC-02H	9833	2 m	5.0 mm
EMC-03H	9833-1	3 m	5.0 mm
EMC-05H	9833-2	5 m	5.0 mm
EMC-12H	9833-3	12 m	5.0 mm
EMC-20H	9833-4	20 m	5.0 mm
EMC-30H	9833-5	30 m	5.0 mm
EMC-54H	9833-6	54 m	5.0 mm

- * QN42H camera head is equipped with 3.5 m camera cable.
- * QN42HL camera head is equipped with 15 m camera cable.
- * EMC-54H cable can be used with MN43H/MN42H/CN43H/CN42H cameras (except UN43H)

Lenses

A wide variety of optional micro and super-micro lenses are available for MN43H and QN43H camera heads. Consult with Elmo dealers for details.

SPECIFICATIONS

Specification with micro camera head (MN43H) connected.

Power supply	DC12V \pm 0.5V	
Power consumption	310 mA	
Image sensor	1/2 inch IT-CCD	
Effective pixels	Horizontal: 768 pixels, Vertical: 494 pixels	
Effective image area	Horizontal: 6.54 mm, Vertical: 4.89 mm (1/2 inch type)	
Scanning system	2:1 interlace	
Scan frequency	Horizontal: 15.734 kHz, Vertical: 59.94 Hz	
Sync system	Internal/External (automatic switching)	
Resolution	Horizontal: More than 470 lines, Vertical: More than 350 lines	
Standard intensity of illumination for objects	30 lx (F1.6, 3000K)	
Minimum intensity of illumination for objects	2.5 lx (F1.6, 3000K)	
S/N ratio	46 dB or more	
Video output	VBS 1.0 V(p-p), (BNC terminal) NTSC system Y/C separation output (S terminal)	
Output impedance	75 Ω unbalanced	
External sync	Input	VBS 1.0 V(p-p) (BNC terminal) NTSC 75 Ω unbalanced
	Adjustment function	Subcarrier phase, H phase
White balance	Automatic/set/manual	
Gain switch (AGC)	SENS UP (+6 dB)/ON/OFF	
Electronic shutter	Automatic, 1/60s, 1/100s, 1/250s, 1/500s, 1/1000s, 1/2000s, 1/4000s, 1/10000s, synchronized scan	
Operating temperature/humidity	14°F to 104°F (-10°C to +40°C)/Less than 90%	
Anti-vibration/shock characteristics	70 m/s ² (10 to 200 Hz)/700 m/s ²	
Weight	Control unit: 0.86 lbs (390g)	
Dimensions (Without protrusion)	Control unit: W: 3.35", H: 1.57", D: 6.14" (W: 85 mm, H: 40 mm, D: 156 mm)	

Design and specifications are subject to change without notice.

PROFILE

Unit : mm [inch]
 ø : diameter

Camera Control Unit

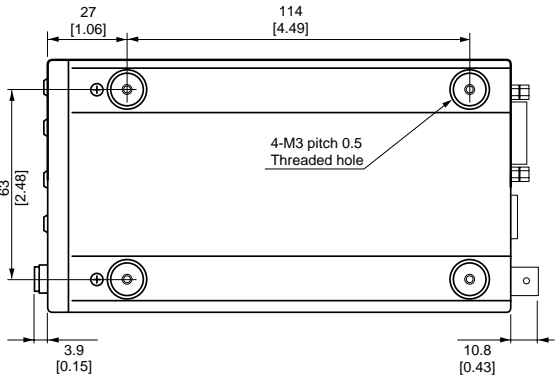
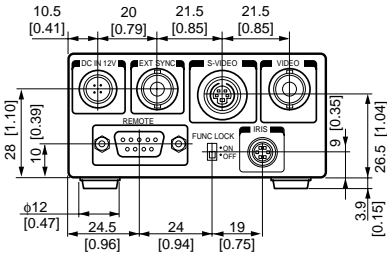
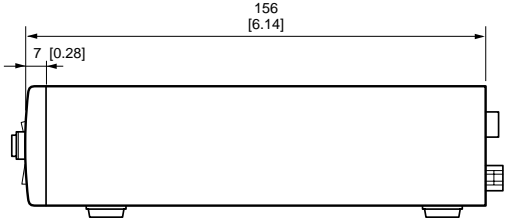
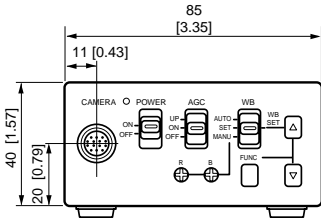

Servicing Instructions for Service Personnel

Connection to Camera Head (MN42H/CN42H)

When connecting to the camera head (MN42H/CN42H), select the internal switch inside the camera controller following to the procedures below.

- ① After turning off the power, remove all the cables connected to the camera controller.
- ② Remove three screws on the bottom chassis of the camera control unit to remove the internal unit.
- ③ Turn off No. 3 of S101 switch located on the component side of the internal circuit unit PC board.

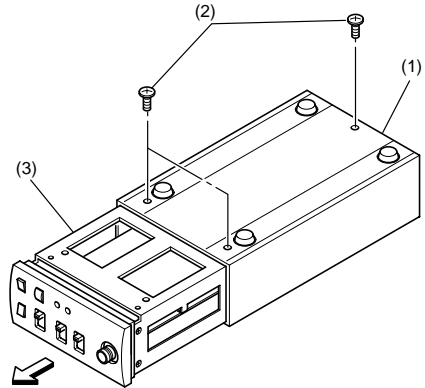

No3 of S101 switch	Applicable camera head to connect
OFF	MN42H CN42H
ON	MN43H CN43H UN43H QN42H QN42HL

Note: Do not change the switch settings other than S101. If you change the settings, the normal image may not be obtained.

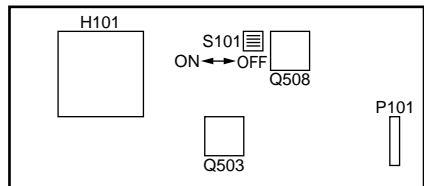

- ④ Perform the reverse procedures to assemble.

ELMO[®] **ELMO CO., LTD.**

6-14, Meizen-cho, Mizuho-ku,
Nagoya, 467-8567 Japan

OVERSEAS SUBSIDIARY COMPANIES

ELMO Mfg. Corp.

1478 Old Country Road,
Plainview, NY 11803-5034
U.S.A.
Tel. 516-501-1400
Fax. 516-501-0429
E-mail:elmo@elmousa.com
Web:http://www.elmousa.com

ELMO Canada Mfg. Corp.

44 West Drive, Brampton,
Ontario, L6T 3T6,
Canada
Tel. 905-453-7880
Fax. 905-453-2391
E-mail:info@elmocanada.com
Web:http://www.elmocanada.com

ELMO (Europe) G.m.b.H.

Neanderstr. 18
40233 Düsseldorf,
Germany
Tel. 0211-376051-53
Fax. 0211-376630
E-mail:elmoeurope@AOL.com
Web:http://www.elmo.de

ELMO and **ELMO** are registered trademarks of ELMO COMPANY, LIMITED.

Printed in Japan (23552125)



Model 7500

Floating Flat Panel Arm



2002
Design Award Winner

The award-winning 7500 Radial Arm is a remarkable work tool. Effortlessly position your monitor exactly where you want it, and add flexibility to your work style. Suspend your flat panel above the desk surface and reclaim your valuable space. Innovative cable management routes cables inside the arm, in order to keep your desk organized. You'll never work the old and cluttered way again!

FEATURES

- ▲ Reposition the monitor with one hand – no knobs to turn
- ▲ Extends up to 27", folds to just 3", vertical range of 18"
- ▲ Tilt monitor up to 200 degrees
- ▲ Includes FLEXmount™ – six different mounting options in one kit
- ▲ Compatible with all VESA® monitors – includes 75mm and 100mm VESA® mounting plates
- ▲ Includes cable management system – cables concealed in arm



Folds into 3" of space



18" of vertical range



Over 200 degrees of monitor tilt



Model 7500



Specifications

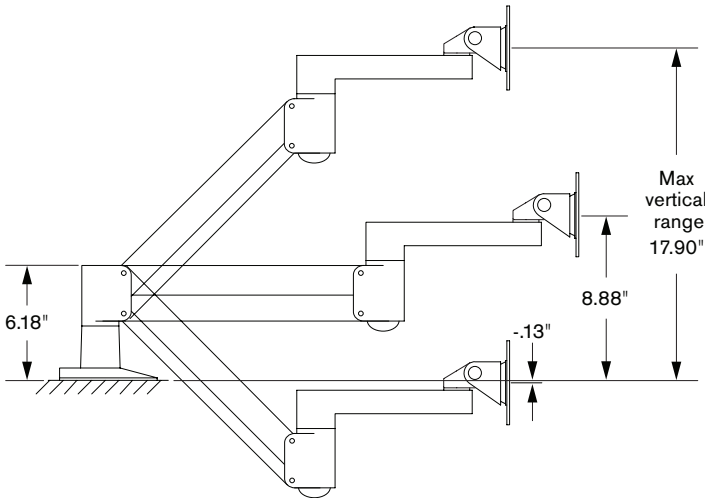

SIDE VIEW
Vertical Range

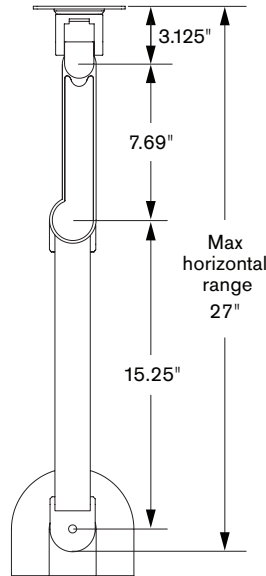

TOP VIEW
Horizontal Range

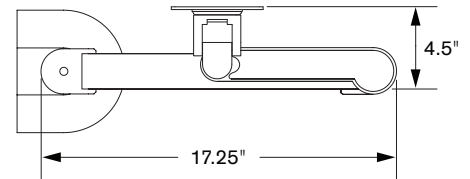

TOP VIEW
Arm Folded

CAPABILITIES

Vertical range	18" (+/- 9" from horizontal)
Horizontal range	27"
Rotation	360 degrees at three joints
Monitor tilt	200 degrees
Monitor pivot	Landscape to portrait
Monitor compatibility	VESA® 75mm and 100mm
Cable management	Cables are concealed in arm
Mounting options	FLEXmount™, Slatwall, Wall, Thru-Desk
Monitor weight/model number	2 - 13 lbs / 7500-500
	6 - 21 lbs / 7500-800
	8 - 27 lbs / 7500-1000
	13.5 - 44 lbs / 7500-1500

FLEXMOUNT™ CONFIGURATIONS

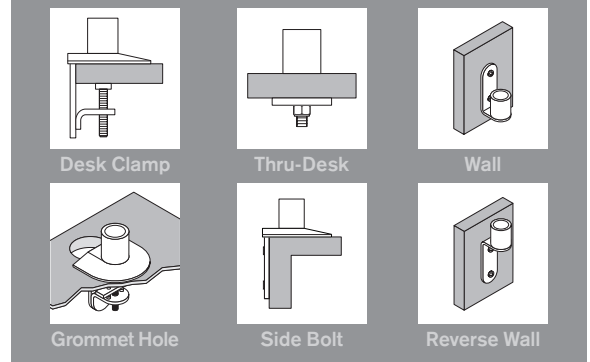

OPTIONAL ACCESSORIES

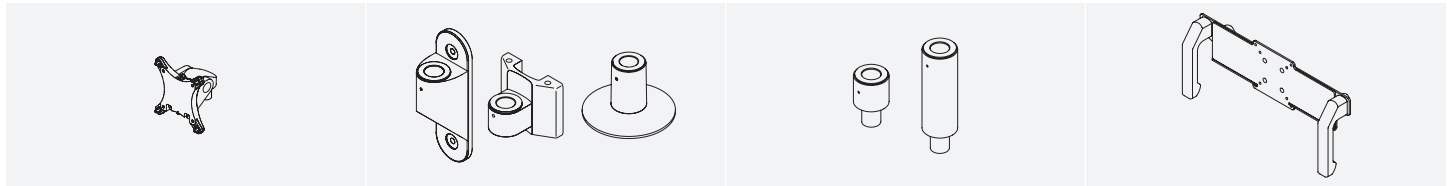

QUICK RELEASE ADAPTERS
Allows for quick attach and release of monitor (8336-QR).

MOUNTS
Wall (8325), slatwall (8246) and thru-desk (8312).

EXTENDER TUBES
Raise the height of your arm. 2" (8171-75-2) and 6" (8171-75-6) extensions available.

HANDLE SET
Provides convenient handles to reposition monitor (8291).

Phone: 800.888.6024 | Fax: 541.779.0829 | E-mail: info@ergoindemand.com | Web: www.ergoindemand.com

This product is protected by one or more of the following U.S. Patent Nos. and other United States and foreign patents applied for: 119,345, 119,346, 1,324,842, 2,470,525, 6,076,785, 6,273,383, 6,409,134, 6,478,274, 6,499,704, 6,505,988, 6,609,691, 6,191,606, 6,719,253, 6,726,167, 6,736,364, 6,783,105, 6,854,698, 6,915,994, 6,935,883, 6,955,328, 6,983,917, 6,986,489, 7,014,157, 7,017,874, 7,048,242, 7,059,574, 7,063,296, 7,066,433, 7,066,435, 7,389,965, D435,852, D491,952, D492,893, D570,853, D575,293.

LMD-B170

LCD Picture Monitors



17-inch cost-effective, lightweight Full HD Basic grade LCD monitor for versatile use

Main Features

- Industry standard 17" screen size and Full HD resolution
- Lightweight and compact with lower power consumption
- Simple all-in-one design style
- Front stereo speakers and Natural ventilation system
- Optimised low-latency I/P conversion
- Video input / Computer input versatility
- Waveform monitor, vector scope and audio level meter display
- User-friendly operability and user interface consistent with PVM/LMD-A Series monitors.
- Camera focus function
- Time code function
- On-screen tally
- User reset, Key inhibit, User Short-cut to function key configuration
- Side by side function
- Flip function
- AC/DC operation with DC Low Power indicator
- Wall-mount capability

Picture Performance	
Panel	a-Si TFT Active Matrix LCD
Picture size (diagonal)	438.2 mm (17 3/8 inches)
Effective picture size (H x V)	381.9 x 214.8 mm (15 1/8 x 8 1/2 inches)
Resolution (H x V)	1920 x 1080 pixels (Full HD)
Aspect	16:9
Colors	Approx. 16.7 million colors
Viewing angle (Panel specification)	80°/60°/80°/80° (typical) (up/down/left/right contrast > 10:1)
Input	
Composite input	BNC (x1), 1.0 Vp-p ±3 dB, sync negative
SDI input	BNC (x2)
HDMI input	HDMI (x1) (HDCP correspondence)
Audio input	Stereo mini jack (x1), -5 dBu 47 kΩ or higher
Parallel remote	RJ-45 Modular connector 8-pin (x1) (Pin-assignable)
DC input	XLR-type 4-pin (male) (x1) DC 12 V to 17 V (output impedance 0.05 Ω or less)
Output	
Composite output	BNC (x1), loop-through, with 75 Ω automatic terminal function
SDI output	BNC (x1)*1 Output signal amplitude: 800 mVp-p ±10% Output impedance: 75 Ω unbalanced
Audio monitor output	Stereo mini jack (x1)
Speaker (built-in) output	2.0 W + 2.0 W (Stereo)
Headphones output	Stereo mini jack (x1)
General	
Power requirements	AC 100 V to 240 V, 0.4 A to 0.3 A, 50/60 Hz DC 12 V to 17 V, 2.7 A to 1.9 A
Power consumption	Approx. 38 W (max.) Approx. 28 W (average power consumption in the default status)
Operating temperature	0°C to 35°C (32°F to 95°F) Recommended: 20°C to 30°C (68°F to 86°F)
Operating humidity	30% to 85% (no condensation)
Storage / Transport temperature	-20°C to +60°C (-4°F to +140°F)
Storage / Transport humidity	0% to 90%
Operating / Storage / Transport pressure	700 hPa to 1060 hPa
Dimensions (W x H x D)*2	423.2 x 303.8 x 68.0 mm (16 3/4 x 12 x 2 3/4 inches) (without monitor feet) 423.2 x 346.5 x 264.4 mm (16 3/4 x 13 3/4 x 10 1/2 inches) (with monitor feet)
Mass	4.1 kg (9 lb 0.6 oz) (without monitor feet) 5.9 kg (13 lb 0.1 oz) (with monitor feet)
Supplied accessories	AC power cord (1), AC plug holder (1), Before Using This Unit (1), CD-ROM (1)

*1 Output from SDI 1 only.

*2 The values for mass and dimensions are approximate.



Dimensions

Front



Side

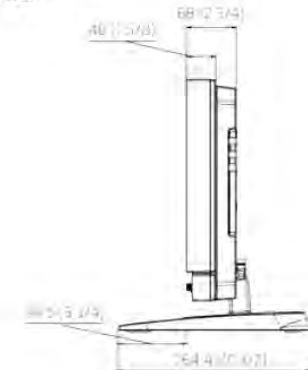

Unit: mm (inches)

LMD-B170

LCD Picture Monitors

Industry standard 17" screen size and Full HD resolution

Industry standard 17" screen is a most user-friendly size to be suitable from a desk-top use to a wall-mounting use, an arm-mounting use and an outfield shooting. The Full HD(1920x1080) resolution is approximately 200% higher resolution than Wide-XGA(1366x768 or 1280x768). FHD is today's minimum requirement for a video production and versatile monitoring purposes of many industries to get a sharp focus and make a pixel to pixel check of a Full HD video with no scaling. The LMD-B170 satisfies both requirements with an excellent cost-performance ratio.



Lightweight and compact with lower power consumption

The LMD-B170 monitor incorporate a lightweight, compact body. The LMD-B170 inherits their all-in-one design style from the PVM/LMD-A series. It has the mandatory interfaces such as SDI, HDMI and composite video with stereo analog audio. You can monitor both embedded audio signals of SDI signal and analog audio signals on the audio level meters of the screen. And also, it has the supplied stand with the tilt function and a wall mounting function for desktop editing, office viewing, etc.



Front stereo speakers and Natural ventilation system



2W+2W front stereo speakers are more powerful than a monaural speaker or a rear speaker system and you can get a good stereophonic effect from them. You can select audio sources from either embedded audio or analog audio. There is no cooling fan inside and it is suitable for a video shooting and critical audio operation.

Optimized Low-latency I/P Conversion

The I/P conversion system delivers automatically optimized signal processing according to input signals with low-latency (less than 0.5 field). This system helps users to edit and monitor for a live production.

Video input / Computer input versatility

The LMD-B170 monitor is equipped with built-in standard input interfaces: HD/SD-SDI (x2), HDMI (HDCP) input (x1) and composite (x1). Multiple computer signals can be received via an HDMI/DVI* interface; the resolution range is from 640 x 480 to 1680 x 1050 pixels. *HDMI-DVI conversion cable required.

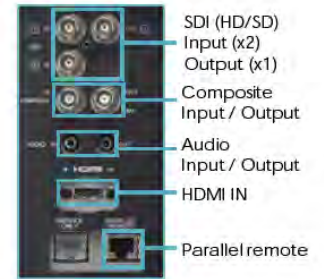

User-friendly Operability and User Interface

A rotary-type switch and seven function-assignable buttons allow users quick and intuitive operation. Operation buttons with LED indicators enable error-free operation, even in dark environments.* The LMD-B170 monitor offer the same functions and operability as PVM-A/ LMD-A Series. This means that both types of monitor can be operated and controlled in the same way. *LED lights can be switched on/off.



Front control panel: Consistent design between the PVM-A and LMD-A Series.

LMD-B170

LCD Picture Monitors

Waveform monitor, vector scope and audio level meter display

An input signal's waveform and vector scope with an SDI embedded 2-channel audio level meter can be displayed on screen. The waveform of a specified line can also be displayed. In conjunction with the Picture & Picture function*, the waveform monitor and vector scope display can monitor two camera signals. In addition, an audio level meter can display the embedded audio signal from the SDI or HDMI input. It can display on screen the ch1 to ch8 or ch9 to ch16.



Waveform monitor

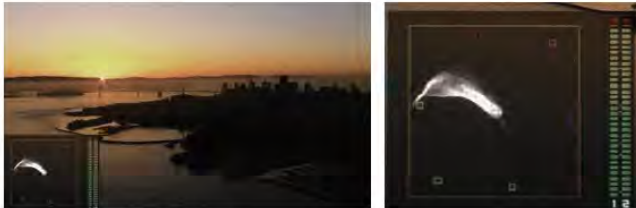

Vector scope

Camera Focus Function

The LMD-B170 monitor can control the aperture level of a video signal, and display images on screen with sharpened edges to help camera focus operation. Further to this, the sharpened edges can be displayed in user-selectable colors (white, red, green, blue, and yellow) for more precise focusing.



Camera focus image

Time code

Tally information can be displayed on screen.



Time code and waveform monitor



Time code, on-screen tally, and 93% area marker

On-screen Tally

The on-screen tally can display in three colors. The position of the tally display can be changed to either the upper or lower section of the screen.



On-screen tally (upper)



On-screen tally (lower)

User reset, Key inhibit, User Short-cut to function key configuration

When multiple users share the same monitor, you need to reset it in a quick operation. User reset function quickly returns the unit to the default settings. Key inhibit protects the required settings of it from any inadvertent operations. For improving speed of the function key configuration, the user can take a short-cut to the settings menu screen by simply holding down one of the Function keys.

LMD-B170

LCD Picture Monitors

Side-by-side

The two picture images* are downsampled using a digital filter and displayed side-by-side. This feature is convenient when making white balance adjustments or determining shooting angles between two cameras. You can use this with the waveform monitor or vector. You can use this with the waveform monitor or vector.

*Two signals must be synchronized.



Flip Function

The Flip function turns the reversed image to a normal view, horizontally or vertically.

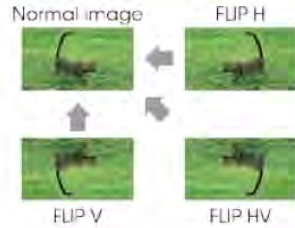

Wall-mount capability

There are also wall-mount 100 mm pitch holes on each monitor's rear panel. Built-in AC circuit allows it to install more easily and flexibly.

DVI Input Signals*

System	HDMI/DVI		
	Resolution	Dot clock (MHz)	TV (Hz)
	640 × 480	25.175	31.5
	1280 × 768	68.25	47.4
	1280 × 1024	108.000	64.0
	1360 × 768	85.500	47.7
	1440 × 900	88.750	55.5
	1680 × 1050	119.000	64.7

* A DVI-HDMI conversion cable is required.

The sides of the displayed picture may be hidden depending on the input signal.

Signal Formats

System	Signal standard				
	Analog composite	SDI			HDMI
		SD/HD	Dual link	3G	
575/50i (PAL)	O	O	-	-	O
480/60i (NTSC)*1	O	O	-	-	O
576/50p	-	-	-	-	O
480/60p*1	-	-	-	-	O
640 x 480/60p*1	-	-	-	-	O
1920 x 1080/24PsF*1*2	-	O	-	-	-
1920 x 1080/25PsF*2	-	O	-	-	-
1920 x 1080/30PsF*1*2	-	O	-	-	-
1920 x 1080/24p*1	-	O	-	-	O
1920 x 1080/25p	-	O	-	-	O
1920 x 1080/30p*1	-	O	-	-	O
1920 x 1080/50i	-	O	-	-	O
1920 x 1080/60i*1	-	O	-	-	O
1920 x 1080/50p	-	-	-	-	O
1920 x 1080/60p*1	-	-	-	-	O
1280 x 720/24p*1	-	O	-	-	-
1280 x 720/25p	-	O	-	-	-
1280 x 720/30p*1	-	O	-	-	-
1280 x 720/50p	-	O	-	-	O
1280 x 720/60p*1	-	O	-	-	O
2048 x 1080/24PsF	-	O	-	-	-
2048 x 1080/25PsF	-	-	-	-	-
2048 x 1080/30PsF	-	-	-	-	-
2048 x 1080/24p	-	-	-	-	-
2048 x 1080/25p	-	-	-	-	-
2048 x 1080/30p	-	-	-	-	-
2048 x 1080/48p	-	-	-	-	-
2048 x 1080/50p	-	-	-	-	-
2048 x 1080/60p	-	-	-	-	-

*1 Compatible with 1/1.001 frame rates.

*2 LMD-B170: 1080/25PsF, 30PsF are displayed as 1080/25PsF, 30PsF on the screen if the Payload ID is added to the video signal, or displayed as 1080/50i, 60i if the ID is not added.





UV-LED Light Source Kit



Preface

Thank you for purchasing the iShot® UV-LED Light Source Kit which utilizes state-of-the-art solid-state illumination technology. The light source is a high output, efficient, compact and lightweight fiber optic light source for industrial applications where space is a premium. The iShot® UV-LED Light Source Kit utilizes eco-friendly solid state LED lighting technology and exhibits instant-on and electronic intensity dimming capability with long operating lifetime. The iShot® UV-LED Light Source Kit is equipped with a Machida fiber receptacle. The iShot® UV-LED Light Source Kit accepts 12V DC input voltage for portable battery operation as well. Please read this operating manual in its entirety before using this product.

Contents

System Symbol Descriptions	3
Warning and Precautions.....	4
System Assembly and Operation	5
Air Flow Paths.....	6
Maintenance and Cleaning	7
Troubleshooting Suggestions.....	7
Repair	7
Manufacture Contact Information	8
Environment.....	8
Electrical Ratings	8
Dimensions	9
Illumination System	9
Product Ordering Information	9
Approvals	10
Warranty	10
Agency Compliance Statements	11
FCC Class A Compliance Statement	11
Canadian Notice	11



System Symbol Descriptions



Caution: Consult accompanying documentation



Caution: Hot Surface



Caution



Hazard Warning



Lamp On



Lamp Off

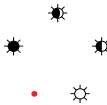

Light; Lighting; Illumination Intensity



UV Light Warning



Storage Humidity



Transport Temperature



Alternating Current



Direct Current



Manufacturer



Do Not Immerse in Any Liquid



Do not dispose of this product as unsorted municipal waste. Prepare this product for reuse or separate collection as specified by Directive 2002/96/EC of the European Parliament and the Council of the European Union on Waste Electronic and Electrical Equipment (WEEE). If this product is contaminated, this directive does not apply.



Warning and Precautions / Mises en garde et précautions



WARNING /
MISE EN GARDE

There are no user serviceable or replacement parts. Do not attempt to dismantle box or remove top cover. / Aucune pièce ne peut être réparée ou remplacée par l'utilisateur. Ne pas essayer de démonter la boîte ou de retirer le couvercle du dessus.

WARNING /
MISE EN GARDE

Only qualified personnel should make electrical inspections and repair of the LED Light Source. / Seul le personnel qualifié doit effectuer les vérifications électriques et les réparations de cette source de lumière à DEL.



WARNING /
MISE EN GARDE

UV light is emitted from this product, Avoid eye and skin exposure to unshielded product. High intensity light at the front of the LED Light Source and at the tip of the fiber-optic bundle will create high temperatures and UV light. To minimize the risk of injury, avoid direct viewing or contact. / L'ultraviolet (UV) est émis par ce produit. Évitez le contact avec les yeux ou la peau. La lampe à haute intensité, située sur le devant de la source de lumière à DEL et sur le bout du faisceau de fibres optiques, va générer beaucoup de chaleur et une lumière vive. Afin de réduire les risques de blessures, évitez de toucher l'appareil ou d'exposer directement l'oeil à la lumière de la lampe."



WARNING /
MISE EN GARDE

To prevent temporary blinding and contact with heated parts, always plug the fiber optic bundle into the LED Light Source before turning the power on. / Pour éviter tout aveuglement temporaire ou contact avec les pièces chauffées, toujours brancher le faisceau de fibres optiques dans la source de lumière à DEL avant la mise en marche.

WARNING /
MISE EN GARDE

Do not use the LED Light Source directly in medical applications. / Ne pas utiliser une source de lumière à DEL directe à des fins médicales.



WARNING /
MISE EN GARDE

Unit MAY BE HOT. Allow to cool before handling. / L'appareil PEUT ÊTRE CHAUD. Il est important de le laisser refroidir avant d'y toucher.



CAUTION /
AVERTISSEMENT

Preferred operation is in the horizontal position. Other operating orientations are permitted. / L'appareil fonctionne de façon optimale à l'horizontale. Les autres orientations sont permises.

CAUTION /
AVERTISSEMENT

Any changes or modifications made to this device that are not expressly approved by manufacturer may void the user's authority to operate the equipment. / Toute modification apportée à cet appareil et non expressément approuvée par le fabricant peut priver l'utilisateur de son droit d'usage.

CAUTION /
AVERTISSEMENT

PROVIDE ADEQUATE VENTILATION TO PREVENT OVER HEATING. Do not drape this light source. Provide a 1.5 inch (3.8 cm) distance between LED Light Source and any solid objects. / ASSURER UNE VENTILATION ADEQUATE AFIN D'ÉVITER LA SURCHAUFFE DE L'APPAREIL. Ne pas couvrir la source de lumière. Laisser au moins 3,8 cm (1,5 po) de distance entre la source de lumière à DEL et tout objet.



CAUTION /
AVERTISSEMENT

DO NOT IMMERSE or store liquids above or on the LED Light Source. / NE PAS IMMERGER la source de lumière à DEL dans des liquides ou placer des liquides au-dessus de celle-ci.

CAUTION /
AVERTISSEMENT

Do not operate device without the cover in place. / Ne pas faire fonctionner l'appareil sans son couvercle.

CAUTION /
AVERTISSEMENT

DO NOT obstruct the airway paths for sufficient cooling is required. / NE PAS obstruer les voies d'aération afin de permettre le refroidissement adéquat de l'appareil.

CAUTION /
AVERTISSEMENT

Please read this entire manual prior to operation. / Lire le présent guide en entier avant d'utiliser l'appareil.



CAUTION /
AVERTISSEMENT

Protection provided by the equipment maybe impaired if not used in accordance with the manufacture recommendations. / La protection assurée par l'équipement risque d'être altérée si l'appareil n'est pas utilisé conformément aux recommandations du fabricant.

System Description and Operation

1. The light source power switch should be in the OFF position. Plug the external 12vdc power supply into the 12vdc connector. **Figure 1.**
2. Plug the external power supply cord into AC receptacle main power.
3. Plug the fiber-optic bundle into the light port and connect the opposite end to the equipment being used. **Figure 2.**
4. Turn the power switch to the ON position. LED indicator light will turn on when light source is powered. **Figure 3.**
5. Adjust the intensity control to set the light intensity to the desired light output level. **Figure 3.**
6. Turn unit OFF when not in use. **Figure 3.**
7. This unit is equipped with a fiber sense interlock feature. The device will not emit light unless fiber cable is completely inserted into the front adapter. Please ensure fiber cable is fully seated into receptacle.

Figure 1. Back View

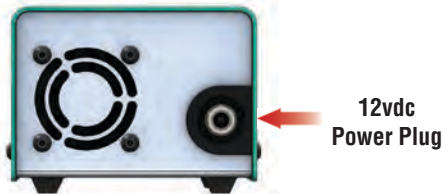
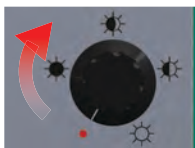

Figure 2. Fiber-Optic Bundle



Figure 3. Front View



**Light Intensity
Knob**



ON/OFF Indicator

**Power ON/OFF
Rotate Knob**



Figure 4. Cooling and Air Flow Paths

1. Do not obstruct air flow paths. This device is designed to have proper forced air cooling paths to maintain thermal stable operation.
2. Place in an area that provides adequate ventilation to prevent unit from overheating. Do not drape the LED Light Source with cloth or objects restricting airflow.
3. Airflow outlets are shown in below red arrow graphics.
4. 1/4-20 UNC mounting stud located in the middle of box bottom side.

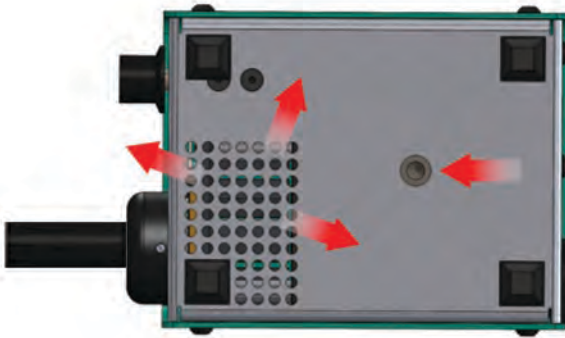
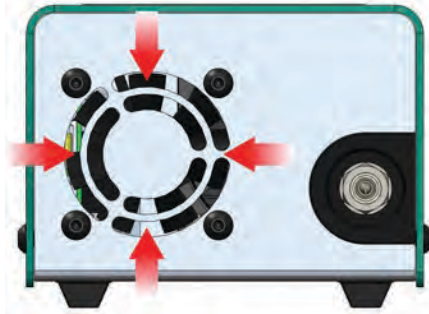

**Threaded
Mounting Stud:
1/4-20 UNC**

Maintenance and Cleaning



1. Turn the LED Light Source off and unplug the power cord from both the wall outlet and the rear of the unit.
2. Wipe the external surfaces clean with a cloth dampened with mild soap and water. **DO NOT IMMERSE.**
3. Wipe the power cords clean with a cloth dampened with mild soap and water. **DO NOT IMMERSE. DO NOT RECONNECT WET.**
4. DO NOT plug the power source into a wall outlet until it is thoroughly dry.
5. It is recommended to periodically clean the optical surface near the LED. Please use a soft cotton swab dipped in Isopropyl Alcohol and wipe the optic surfaces and allow to thoroughly dry prior to use.

Troubleshooting Suggestions

In the event the unit stops functioning, try the following steps to operate light source. The power supply exhibits internal protection circuitry for user safety precautions and will shutdown during certain instances. This equipment has been tested to ESD conditions according IEC 61326-1 and performs to performance criterion C. This means, that under certain conditions the overvoltage protection of the power supply may turn the power supply output and the unit off to prevent damage to the unit. In such case the power supply must be disconnected from main power to reset this fault condition. In the event the unit suddenly turns off, turn the unit off. Unplug the power supply from mains voltage (120V/ 230V). Wait ~5 seconds and plug the power supply back into mains voltage. Turn the unit on.

1. Turn OFF light source by rotating intensity control knob counterclockwise until the switch clicks off.
2. Completely disconnect power supply from both light source and mains (power plug into ac outlet).
3. Wait for ~5 seconds until power supply discharges as observed on the power supply LED indicator will turn off.
4. Reconnect power supply to both ac to main voltage and dc connector to light source.
5. Turn ON light source by rotating knob clockwise until clicks on and LED indicator light is on.
6. Insert fiber cable completely to deactivate fiber sense interlock feature.
7. Rotate knob to increase light output intensity to desired output.

Repair

For repair information, please contact our team at:

Phone: Office: 908-496-8008

Email: support@intertest.com



Manufacture Information

Supplier Name: USHIO America, Inc.
Address: 5440 Cerritos Ave.
Cypress, CA 90630

Model or Type: ULB-35rvi



Environment Ratings

Operating Temperature: 41° F to 104° F (5° C to 40° C)
Humidity: 0 to 95% rh (non-condensing)
Storage Temperature: -10° F to 140° F (-20° C to 60° C)
Humidity: 30 to 75% rh
Atmospheric Pressure: 700 hpa to 1060 hpa
Mode of Operation: Continuous
Safety System Classification: Class II
System Pollution Degree: 2
Installation Category: II

Electrical Ratings

External Power Supply Ratings:

Input: 100 - 240 V~, 50/60 Hz, 1.4 A max
Output: +12 V , 5.0 A
Recommended PS: UAI Part: UPS-00

ULB-35 Power Ratings:

Voltage: +12V DC; 14V DC maximum
Current: 5.0 amp

Battery: USHIO America, Inc. recommends using a UR (or other recognized testing laboratory) recognized battery rated at 12V/8Ahr or equivalent with a minimum 5.0 amp current limit rating.



Dimensions

Length:	127MM (5.0")
Width:	90MM (3.5")
Height:	68MM (2.7")
Weight:	0.45 kg (1.0 lbs)



Illumination Source

Type:	LED Custom Module
Wavelength:	365-370nm Peak
Power:	50 Watts
Average LED Life*:	10,000+ Hours

* Based on LED manufacturer rated wattage and thermal operation.

Product Ordering Information

Part Number	Description
EM14466	35W RVI UV LED Light Source, Machida
EM66693	Universal Input Power Supply (60W 12V P/S)
EM11890	US power cord (NEMA 5-15P to IEC C13)



Approvals



The CE mark on this product indicates that it has been tested to and conforms to the provisions noted within the following directives:

Low Voltage: 2014/35/EU
EMC: 2014/30/EU
RoHS 2: 2011/65/EU

In accordance with the following standards:

EN 61010-1
IEC 61326-1
EN 61326-1
IEC/EN 61000 3-2
IEC/EN 61000 3-3
EN 50581
IEC/EN 62471:2006 LED Photobiological safety lamp standard, categorized as Risk Group 3 (High-Risk).



Conforms to UL Std 61010-1
Certified to CSA Std C22.2 No. 61010-1

Intertek
4009043



WEEE
(www.lamprecycle.org)

Limited Warranty

USHIO America warrants the LED Light Source, when new, to be free of defects in material and workmanship and to perform in accordance with the manufacturer's specifications when subject to normal use and service for a period of one year from the date of purchase from USHIO America or an authorized agent. USHIO America will either repair or replace any components found to be defective or at variance from the manufacturer's specifications within this time at no cost to the customer. It shall be the purchaser's responsibility to return the instrument to the authorized distributor, agent, or service representative.

This limited warranty does not cover the breakage or failure due to tampering, misuse, neglect, accidents, improper installation, modification, shipping, or to improper maintenance, service, and cleaning procedures. This limited warranty is also void if the instrument is not used in accordance with the manufacturer's recommendations or if required service is performed by anyone other than USHIO America or an authorized agent. The purchase date determines limited warranty requirements. No other express or implied limited warranty is given.



Agency Compliance Statements

This device complies with part 15 of the FCC Rules. Operation is subject to the following two conditions: (1) this device may not cause harmful interference, and (2) this device must accept any interference received, including interference that may cause undesired operation.

FCC Class A Compliance Statement

This equipment has been tested and found to comply with the limits for a Class A digital device, pursuant to part 15 of the FCC Rules. These limits are designed to provide reasonable protection against harmful interference when the equipment is operated in a commercial environment. This equipment generates, uses, and can radiate radio frequency energy and, if not installed and used in accordance with the instruction manual, may cause harmful interference to radio communications. Operation of this equipment in a residential area is likely to cause harmful interference, in which case the user will be required to correct the interference at his own expense.



CAUTION

Any changes or modifications made to this device that are not expressly approved may void the user's authority to operate the equipment.

NOTE

To maintain compliance with FCC Rules and Regulations, cables connected to this device must be shielded cables, in which the cable shield wire(s) have been grounded (tied) to the connector shell.

Canadian Notice

This equipment does not exceed the Class A limits for radio noise emissions as described in the Radio Interference Regulations of the Canadian Department of Communications.

Le present appareil numerique n'emet pas de bruits radioelectriques dépassant les limites applicables aux appareils numeriques de la classe A prescrites dans le Reglement sur le brouillage radioelectrique edicte par le ministere des Communications du Canada.



Sold By:



www.intertest.com

303 State Route 94
Columbia, NJ 07832 USA
Office: 908-496-8008
Toll Free (U.S.): 800-535-3626
Fax: 908-496-8004



MADE IN USA

Rev1-092017

MIDORI™

ULB-35 SERIES LED LIGHT SOURCE



OPERATING MANUAL

Preface

Thank you for purchasing the Midori™ fiber optic illuminator which utilizes state-of-the-art solid-state illumination technology. The light source is a high output, efficient, compact and lightweight fiber optic light source for industrial applications where space is a premium. The ULB-35 series fiber illuminators utilize eco-friendly solid state LED lighting technology, exhibits instant-on and electronic intensity dimming capability with long operating lifetime. The Midori™ ULB-35 LED fiber illuminator is equipped with an ACMI fiber receptacle with separate Storz and Olympus style screw-in adapters available to accommodate these other common fiber cable types. The ULB-35 accepts 12V DC input voltage for portable battery operation as well. Please read this operating manual in its entirety before using this product.

Contents

System Symbol Descriptions	3
Warning and Precautions.....	4
System Assembly and Operation	5
Air Flow Paths.....	6
Maintenance and Cleaning	7
Troubleshooting Suggestions.....	7
Repair	7
Manufacture Contact Information	8
Environment.....	8
Electrical Ratings	8
Dimensions	9
Illumination System	9
Product Ordering Information	9
Approvals	10
Warranty	10
Agency Compliance Statements	11
FCC Class A Compliance Statement	11
Canadian Notice	11

System Symbol Descriptions



Caution: Consult accompanying documentation



Caution: Hot Surface



Caution



Hazard Warning



Lamp On



Lamp Off

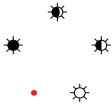

Light; Lighting; Illumination Intensity



Bright Light



Storage Humidity



Transport Temperature



Alternating Current



Direct Current



Manufacturer



Do Not Immerse in Any Liquid



Do not dispose of this product as unsorted municipal waste. Prepare this product for reuse or separate collection as specified by Directive 2002/96/EC of the European Parliament and the Council of the European Union on Waste Electronic and Electrical Equipment (WEEE). If this product is contaminated, this directive does not apply.

Warning and Precautions / Mises en garde et précautions



WARNING /
MISE EN GARDE

There are no user serviceable or replacement parts. Do not attempt to dismantle box or remove top cover. / Aucune pièce ne peut être réparée ou remplacée par l'utilisateur. Ne pas essayer de démonter la boîte ou de retirer le couvercle du dessus.



WARNING /
MISE EN GARDE

Only qualified personnel should make electrical inspections and repair of the LED Light Source. / Seul le personnel qualifié doit effectuer les vérifications électriques et les réparations de cette source de lumière à DEL.

The high intensity light at the front of the LED Light Source and at the tip of the fiber-optic bundle will create high temperatures and bright light. To minimize the risk of injury, avoid direct viewing or contact. / La lampe à haute intensité, située sur le devant de la source de lumière à DEL et sur le bout du faisceau de fibres optiques, générera beaucoup de chaleur et une lumière vive. Afin de réduire les risques de blessures, éviter de toucher l'appareil ou d'exposer directement l'œil à la lumière de la lampe.

WARNING /
MISE EN GARDE

To prevent temporary blinding and contact with heated parts, always plug the fiber optic bundle into the LED Light Source before turning the power on. / Pour éviter tout aveuglement temporaire ou contact avec les pièces chauffées, toujours brancher le faisceau de fibres optiques dans la source de lumière à DEL avant la mise en marche.

WARNING /
MISE EN GARDE

Do not use the LED Light Source directly in medical applications. / Ne pas utiliser une source de lumière à DEL directe à des fins médicales.



WARNING /
MISE EN GARDE

UNIT MAY BE HOT. Allow to cool before handling. / L'appareil PEUT ÊTRE CHAUD. Il est important de le laisser refroidir avant d'y toucher.



CAUTION /
AVERTISSEMENT

Preferred operation is in the horizontal position. Other operating orientations are permitted. / L'appareil fonctionne de façon optimale à l'horizontale. Les autres orientations sont permises.

CAUTION /
AVERTISSEMENT

Any changes or modifications made to this device that are not expressly approved by manufacturer may void the user's authority to operate the equipment. / Toute modification apportée à cet appareil et non expressément approuvée par le fabricant peut priver l'utilisateur de son droit d'usage.

CAUTION /
AVERTISSEMENT

PROVIDE ADEQUATE VENTILATION TO PREVENT OVER HEATING. Do not drape this light source. Provide a 1.5 inch (3.8 cm) distance between LED Light Source and any solid objects. / ASSURER UNE VENTILATION ADEQUATE AFIN D'ÉVITER LA SURCHAUFFE DE L'APPAREIL. Ne pas couvrir la source de lumière. Laisser au moins 3,8 cm (1,5 po) de distance entre la source de lumière à DEL et tout objet.



CAUTION /
AVERTISSEMENT

DO NOT IMMERSE or store liquids above or on the LED Light Source. / NE PAS IMMERGER la source de lumière à DEL dans des liquides ou placer des liquides au-dessus de celle-ci.

CAUTION /
AVERTISSEMENT

Do not operate device without the cover in place. / Ne pas faire fonctionner l'appareil sans son couvercle.

CAUTION /
AVERTISSEMENT

DO NOT obstruct the airway paths for sufficient cooling is required. / NE PAS obstruer les voies d'aération afin de permettre le refroidissement adéquat de l'appareil.

CAUTION /
AVERTISSEMENT

Please read this entire manual prior to operation. / Lire le présent guide en entier avant d'utiliser l'appareil.



CAUTION /
AVERTISSEMENT

Protection provided by the equipment maybe impaired if not used in accordance with the manufacture recommendations. / La protection assurée par l'équipement risque d'être altérée si l'appareil n'est pas utilisé conformément aux recommandations du fabricant.

System Description and Operation

1. The light source power switch should be in the OFF position. Plug the external 12vdc power supply into the 12vdc connector. **Figure 1.**
2. Plug the external power supply cord into AC receptacle main power.
3. Plug the fiber-optic bundle into the light port and connect the opposite end to the equipment being used. **Figure 2.**
4. Turn the power switch to the ON position. LED indicator light will turn on when light source is powered. **Figure 3.**
5. Adjust the intensity control to set the light intensity to the desired light output level. **Figure 3.**
6. Turn unit OFF when not in use. **Figure 3.**

Figure 1. Back View

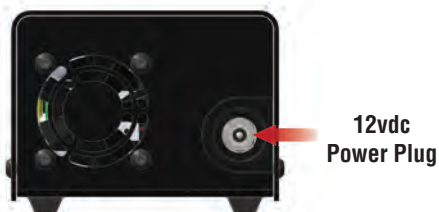

Figure 2. Fiber-Optic Bundle

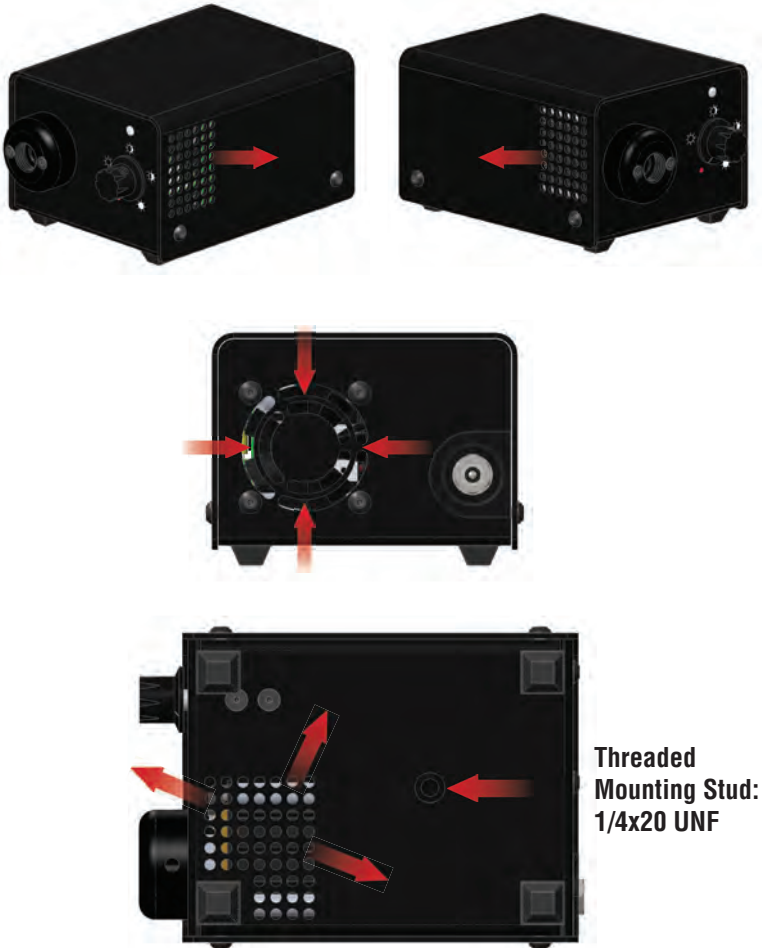

Figure 3. Front View



Figure 4. Cooling and Air Flow Paths

1. Do not obstruct air flow paths. This device is designed to have proper forced air cooling paths to maintain thermal stable operation.
2. Place in an area that provides adequate ventilation to prevent unit from overheating. Do not drape the LED Light Source with cloth or objects restricting airflow.
3. Airflow outlets are shown in below red arrow graphics.
4. 1/4-20 UNF mounting stud located in the middle of box bottom side.



Maintenance and Cleaning



1. Turn the LED Light Source off and unplug the power cord from both the wall outlet and the rear of the unit.
2. Wipe the external surfaces clean with a cloth dampened with mild soap and water. **DO NOT IMMERSE.**
3. Wipe the power cords clean with a cloth dampened with mild soap and water. **DO NOT IMMERSE. DO NOT RECONNECT WET.**
4. **DO NOT** plug the power source into a wall outlet until it is thoroughly dry.
5. It is recommended to periodically clean the reflective optical surface near the LED. Please use a soft cotton Q-tip dipped in Isopropyl Alcohol and wipe the reflective optic surfaces and allow to thoroughly dry prior to use.

Troubleshooting Suggestions

In the event the unit stops functioning, try the following steps to operate light source. The power supply exhibits internal protection circuitry for user safety precautions and will shutdown during certain instances. This equipment has been tested to ESD conditions according to IEC 61326-1 and performs to performance criterion C. This means, that under certain conditions the overvoltage protection of the power supply may turn the power supply output and the unit off to prevent damage to the unit. In such case the power supply must be disconnected from main power to reset this fault condition. In the event the unit suddenly turns off, turn the unit off. Unplug the power supply from mains voltage (120V/ 230V). Wait ~5 seconds and plug the power supply back into mains voltage. Turn the unit on.

1. Turn OFF light source by rotating intensity control knob counterclockwise until the switch clicks off.
2. Completely disconnect power supply from both light source and mains (power plug into ac outlet).
3. Wait for ~5 seconds until power supply discharges as observed on the power supply LED indicator will turn off.
4. Reconnect power supply to both ac to main voltage and dc connector to light source.
5. Turn ON light source by rotating knob clockwise until clicks on and LED indicator light is on.
6. Rotate knob to increase light output intensity to desired output.

Repair

For repair information, please contact Customer Service at:

Telephone: (714) 236-8600

Email: customerservice@ushio.com

Manufacture Contact Information

Supplier Name:	Ushio America, Inc.
Address:	5440 Cerritos Ave. Cypress, CA 90630
Telephone:	714-236-8600
Email	customerservice@ushio.com
Website:	www.ushio.com
Model or Type:	ULB-35



Environment Ratings

Operating Temperature:	41° F to 104° F (5° C to 40° C)
Humidity:	0 to 95% rh (non-condensing)
Storage Temperature:	-10° F to 140° F (-20° C to 60° C)
Humidity:	30 to 75% rh
Atmospheric Pressure:	700 hpa to 1060 hpa
Mode of Operation:	Continuous
Safety System Classification:	Class II
System Pollution Degree:	2
Installation Category:	II

Electrical Ratings

External Power Supply Ratings:

Input:	100 - 240 V~, 50/60 Hz, 1.4 A max
Output:	+12 V $\overline{\text{---}}$, 5.0 A
Recommended PS:	UAI Part: UPS-00

ULB-35 Power Ratings:

Voltage:	+12V DC; 14V DC maximum
Current:	3.4 amp

Battery: Ushio America, Inc. recommends using a UR (or other recognized testing laboratory) recognized battery rated at 12V/9Ah or equivalent with a minimum 3.5 amp current limit rating.

Dimensions

Length:	127MM (5.0")
Width:	90MM (3.5")
Height:	68MM (2.7")
Weight:	0.45 kg (1.0 lbs)



Illumination Source

Type:	LED Custom Module
Color Temperature:	5700 K - 6500 K Nominal
Power:	35 Watts
Average LED Life*:	50,000+ Hours

* Based on LED manufacturer rated wattage and thermal operation.

Product Ordering Information

Product ID	Description	Order Code
ULB-35p	35W LED Light Source; OEM Black	1003883
UPS-00	Universal Input Power Supply	1003879
UPC-US	US power cord; EN60320-C7	1003881
UPC-EU	EU Power cord EN60320-C7	1003880
UPC-UK	UK Power cord EN60320-C7	1003882
UPC-AU	AU Power Cord; EN60320-C7	1004095
50159	Storz Fiber Adapter; screw-in	50159
50160	Olympus Fiber Adapter; screw-in	50160
LB-CLP	12vdc Car Power Plug Adapter	LB-CLP
UAC-01	Portable Light Case	5002496
UPS-03	12vdc LiP Battery Pack	5002493

Approvals



The CE mark on this product indicates that it has been tested to and conforms to the provisions noted within the following directives:

Low Voltage: 2014/35/EU
EMC: 2014/30/EU
RoHS 2: 2011/65/EU

In accordance with the following standards:

EN61010-1
IEC 61326-1
EN 61326-1
IEC 62471
IEC/EN 61000 3-2
IEC/EN 61000 3-3
EN 50581



Intertek
4009043

Conforms to UL Std 61010-1
Certified to CSA Std C22.2 No. 61010-1



WEEE
(www.lamprecycle.org)

Limited Warranty

USHIO America warrants the LED Light Source, when new, to be free of defects in material and workmanship and to perform in accordance with the manufacturer's specifications when subject to normal use and service for a period of two years from the date of purchase from USHIO America or an authorized agent. USHIO America will either repair or replace any components found to be defective or at variance from the manufacturer's specifications within this time at no cost to the customer. It shall be the purchaser's responsibility to return the instrument to the authorized distributor, agent, or service representative.

This limited warranty does not cover the breakage or failure due to tampering, misuse, neglect, accidents, improper installation, modification, shipping, or to improper maintenance, service, and cleaning procedures. This limited warranty is also void if the instrument is not used in accordance with the manufacturer's recommendations or if required service is performed by anyone other than USHIO America or an authorized agent. The purchase date determines limited warranty requirements. No other express or implied limited warranty is given.

Agency Compliance Statements

This device complies with part 15 of the FCC Rules. Operation is subject to the following two conditions: (1) this device may not cause harmful interference, and (2) this device must accept any interference received, including interference that may cause undesired operation.

FCC Class A Compliance Statement

This equipment has been tested and found to comply with the limits for a Class A digital device, pursuant to part 15 of the FCC Rules. These limits are designed to provide reasonable protection against harmful interference when the equipment is operated in a commercial environment. This equipment generates, uses, and can radiate radio frequency energy and, if not installed and used in accordance with the instruction manual, may cause harmful interference to radio communications. Operation of this equipment in a residential area is likely to cause harmful interference, in which case the user will be required to correct the interference at his own expense.



CAUTION

Any changes or modifications made to this device that are not expressly approved may void the user's authority to operate the equipment.

NOTE

To maintain compliance with FCC Rules and Regulations, cables connected to this device must be shielded cables, in which the cable shield wire(s) have been grounded (tied) to the connector shell.

Canadian Notice

This equipment does not exceed the Class A limits for radio noise emissions as described in the Radio Interference Regulations of the Canadian Department of Communications.

Le present appareil numerique n'emet pas de bruits radioelectriques depassant les limites applicables aux appareils numeriques de la classe A prescrites dans le Reglement sur le brouillage radioelectrique edicte par le ministere des Communications du Canada.

Versatile IP Test Monitor

7 inch wide touch screen



Video Surveillance Products (Installation and management)

- This product is for CCTV system installation and management. Some problems may occur with inappropriate use.
- Please read the instructions prior to its use and keep it with the warranty certificate.

Cautions for use of this product

- If you give excessive shock to this product or drop it, LCD may be damaged. Therefore, have a special care not to break it. (The damaged LCD is not available for free A/S even in warranty.)
- Do not spray water directly and wipe this product gently with a dry towel when you clean it. Have a special care for LCD shock during cleaning.
- When using outdoors, be careful to prevent water or other foreign objects from entering this product. (It may cause fire or malfunction of the product. In this case, free A/S is not available even in warranty.)
- Do not apply power to video input connectors.
- Do not install the product in the following places: extremely low or high temperature conditions; places exposed to rain, snow, or high humidity; places containing or exposed to oil and gas; places exposed to vibration and shock; places under direct sunlight or exposed to outdoor weather conditions; places exposed to radio waves (RF) or near to power lines (for EX-SDI, HD-SDI). It may cause low performance or malfunction of the unit.
- Use exclusive adapter only for recharging the built-in batteries. Otherwise, it may cause fire or explosion. (When the red LED of the adapter is flickering during recharging, please contact where you purchased this product)
- The warranty for the built-in batteries is for 6 months from the purchase date.
- LI-Polymer Batteries (11.1v / 5,680mAh) are built in this product. Do not disassemble or short-circuit the batteries. (Free A/S is not available in this case)
- If the charger terminal is short-circuited or has the polarity in opposite way, the batteries may be damaged.
- Keep this product in the provided bag to prevent the main body and LCD from getting cracked.
- Do not put any conductive materials such as screwdrivers, coins, metal parts, etc.
- Do not place this product to where water is falling or splashing and where has water inside such as flower vases.
- Stop using this product immediately and contact where you purchased this product when any smoke or smell is produced.
- Do not disassemble this product on your own and contact where you purchase this product when it does not work properly. (You do not have free A/S for any failure caused by your own decomposition)
- When this product is left for a long time and discharged, connect to WI-FI. When WI-FI is connected, the time is set automatically.
- When Micro SD Card is bent or cracked, it may cause some problems.
- When the life of Micro SD Card comes to an end, the video storage and playback are not available.
- Reset it to factory defaults if the product is paused frequently or does not work properly.
- Press and hold the power button for about 7 seconds to shut down this product forcibly when it is paused during use or the touch pad or D-pad does not work properly. After then, please turn it on again for use.
- Press and hold the power button for about 7 seconds to shut down this product forcibly when it is paused during use or just after resetting to factory defaults. After then, please turn it on again for use

Cautions for use of the memory card

Checklist for the memory card selection

- Micro SD/SDHC/SDXC memory cards are compatible with this test monitor.
- Compatibility between memory cards and this test monitor depends on the brand and type of memory cards.
- Memory cards from the following brands are recommended for use with this test monitor.
Micro SD/SDHC/SDXC Memory Card: Sandisk, Transcend, Samsung
- The recommended capacity of Micro SD card is 4GB~64GB.
- When the frame rate is 30fps or lower in saving video, a memory card of class 6 or higher is recommended. When the frame rate is 31fps or higher, a memory card of class 10 or UHS-1 is recommended.
- Android supports the FAT32 method only. A SD memory card must be formatted prior to its use, and a separate program is required to use a memory card with 64GB or higher capacity as it is unavailable to format it in FAT32 method in the window.

Memory card type and capacity

- Please check the memory card logo on the label of the memory card.

Type	Capacity
Micro SD Card	2GB Memory Card
Micro SDHC Card	4~32GB Memory Card
Micro SDXC Card	64GB Memory Card

Memory Card Classes

- You can find a number marked in a circle on the memory card. It is called 'Class'.
- The classes of memory cards indicate the transmission speed per second and a high-class memory card is required for high quality video transmission.

Type	Capacity
Class 2	The class 2 can transmit 2MB per second and is not appropriate for video and/or voice storage.
Class 4	The class 4 can transmit 4MB per second and is not appropriate for video and/or voice storage.
Class 6	The class 6 can transmit 6MB per second and is appropriate for low- quality video and/or voice storage.
Class 10	The class 10 can transmit 10MB per second and is appropriate for high- quality video and/or voice storage.
Class UHS	The class UHS can transmit 50MB per second and is appropriate for high- quality video and/or voice storage.

Cautions for use of the memory card

Removal of the memory card

- Errors may occur in the saved file if you remove the memory card during use.
- Please refer to the following instructions to remove the memory card.



Main Home

- ① Enter My Apps page from the Home screen.
- ② Select Settings.

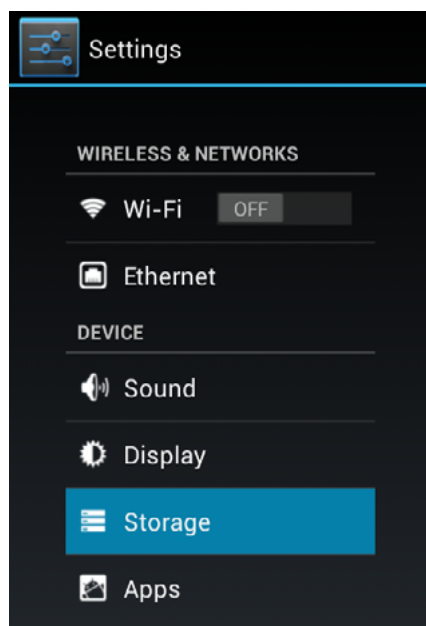

Settings Menu

- ③ Click Storage on the Settings menu.

Cautions for use of the memory card

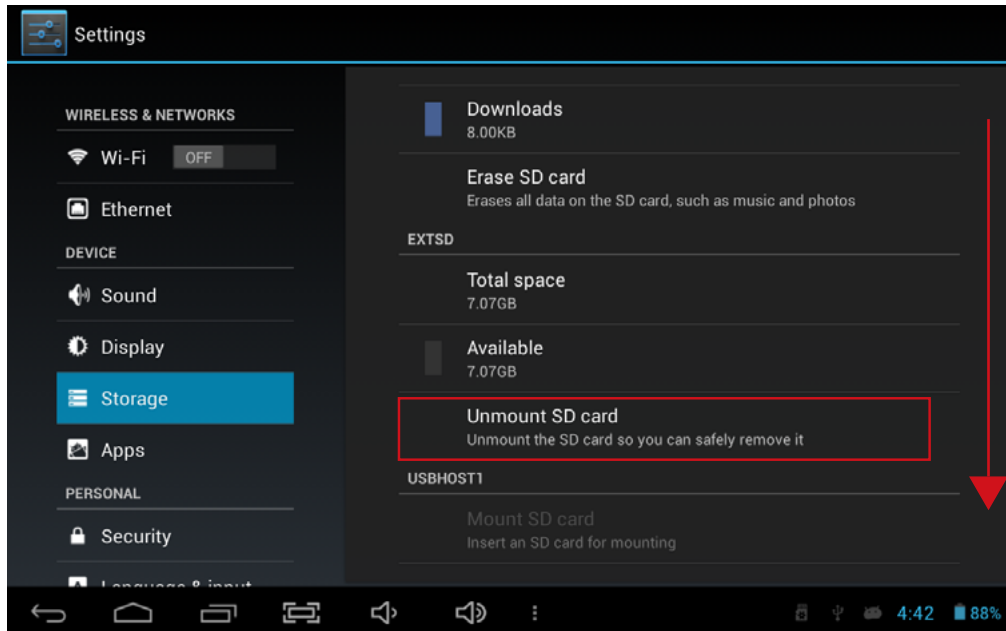

Storage Screen

- ④ Check if the Unmount SD card is enabled in the storage page.
 - Recheck the inserted SD card status if the Unmount SD card is disabled even though the SD card is inserted. Please remove the SD card and insert it again.

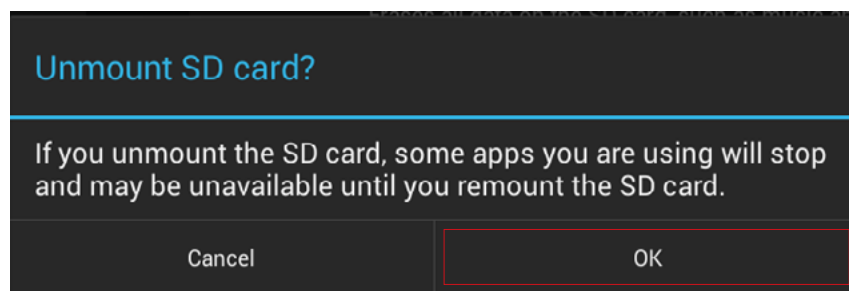

Unmount Screen

- ⑤ Select OK when a message for unmounting the SD card is shown on the screen.
 - If the SD card unmount is still enabled even after selecting OK button, please reboot this test monitor and try the steps above again.
 - For SD card insertion, no settings are required.

Overview

Table of Contents

	Overview	2	Cautions for use of this product
		3	Cautions for use of the memory card
		6	Table of contents
		8	Introduction & Features
		9	IP App. functions
		10	Viewer App. functions
		11	Product components
Product Parts and Descriptions		12	Top interface
		13	Front interface
		14	Bottom Navigation and Tool Bar
		15	Backside interface & Connection diagram
		16	Launcher
IP App. Functions		17	IP camera connection and settings
		18	IP camera connection by LAN
		20	IP camera connection by a DHCP server
		21	Checking items prior to the camera discovery and connection
		22	IP device discovery
		23	IP camera connection and settings
		25	Utilize configuration
		26	IP App. Main page
		27	PoE voltage check, Menu in the IP App. main page & Configuration rearrangement
		28	IP device search
		29	Camera settings
		30	Camera network settings
		31	Edit media profile
		32	Live video main page
		33	Live video menu bar
		34	Video recording
		35	Snapshot capturing
		36	Audio input & Video output codec change
		37	Pan/Tilt functions
		38	Zoom function
		39	Presets & Video information
		40	Configuration storage
		41	Camera configuration context menu
		42	Monitor IP settings
		43	IP address selection & Link-local address
		44	Ping test

NetWork

Overview

Table of Contents

Viewer App. Functions	45	Main page
SDI / HDMI / HD Analog	46	Supported resolution
	47	Signal level meter function
	48	Focus meter function & CRC error count function
	49	Video menu bar
	50	PTZ
	51	RS-485 Tx.
	52	RS-485 Rx. & Analyze function
	53	UTC
	54	Video recording
	55	Video capturing & How to use gallery
	56	PoC function
	57	User settings
	58	App. update, USB Lan Card
	59	Specifications
	61	FAQ
	63	Extra features
	64	Warranty certificate

Overview

Introduction

This IP test monitor is a multifunctional test monitor based on Android system for convenient monitoring and maintenance for video surveillance systems.

As this tester supports ONVIF, the international standard for IP security products, it is possible to connect with various network cameras easily and check their video. It can supply PoE (Power over Ethernet) to a PoE camera. The test monitor is feature-rich with a variety of functions such as network camera setting change and PTZ control. It is particularly optimized for camera installation.

In addition, you can check live video of HD/EX-SDI, Analog and HD Analog cameras, and for HD/EX-SDI, if your camera is a PoC (Power over Coaxial) camera, this test monitor can supply power to the camera over coaxial cable. RS-485 is supported for RS-485 data communication and then the camera PTZ and OSD menu control are available in a remote distance.

For HD Analog (AHD/TVI/CVI) and CVBS, the camera PTZ and OSD control are available by UTC (Up the Coaxial) function.

This test monitor has 7" IPS capacitance-type touch screen in 1280x800 resolution on the front side, D-pad(directional keys) and other function buttons on the right side for the user's convenience. Also, optical bonding is applied for visibility in outside work to provide the screen with clear image. This test monitor provides the best solution to users for video surveillance camera installation and system maintenance as it is compatible with various types of cameras (over 7,000 models of ONVIF conformant network cameras.).

Features

- 1280 x 800 High resolution IPS 7 inch TFT-LCD panel with capacitance-type touch screen
- LED Back light for clear image
- Optical bonding applied for outdoor environment
- Power supply to camera (DC12V/ 500mA) by using DC Jack
- USB Port (2.0) with 5V power out
- Micro SD card port for internal capacity expansion (Card is optional)
- Dual speaker for sound play
- Sleep mode to save the battery(automatically power off after 10 minutes in its sleep mode)
- 5,680mAH Li-polymer battery
- Exclusive charger for this test monitor (In-vehicle charger is optional)
- Portable bag with the strap for hands-free use and convenient installation
- Rubber handle cover on both sides of this tester for prevention of slipperiness
- Guard cover to protect BNC connectors
- Test monitor stand for convenient monitoring
- LED indicators for D-pad(directional keys) and other function buttons
- Miracast function for synchronization of this test monitor with an external device

Overview

IP App. functions

- **IP Camera search**
Discover the IP address of your network camera connected to this test monitor or all network cameras on your LAN by Auto Discovery function.
- **Live video checking**
Real-time video monitoring of your connected IP camera.
- **IP camera settings**
IP camera video preview and IP camera address setting change available when building IP systems.
- **Support various types of devices**
Camera video display available in various types such as ONVIF, RTSP, MJPEG, etc.
- **Auto-complete feature for camera setting information**
Easy camera settings by the auto-complete feature once the camera setting information is saved.
- **Support various transport protocols**
Support HTTP, TCP and UDP.
- **Camera configuration storage**
Save network camera configuration to the IP App. main page.
- **Monitor IP setting**
IP address change of the test monitor
- **Ping test for network status check**
Ping a network camera connected with this test monitor or on your LAN to check the network connection status.
- **PoE Voltage check**
Check the voltage of the PoE supplied from an item.
- **PoE Output**
PoE output up to 30W for the network PoE camera operation.
- **Video recording and snapshot**
Video recording and snapshot for each signal and real-time playback.
- **PTZ function**
Pan/Tilt/Zoom/Preset the connected PTZ camera.
- **Support multiple audio formats: AAC, G.711 μ -Law, G.711 A-law**
Playback of the audio for the connected camera.
- **Real-time video information checking**
Data/frame transmission rates, video/audio codec, required ports, RTP transmission quality
- **Media configuration change**
Modify or delete the set profile.
- **Camera initialization**
Reset a camera to factory defaults.
- **ONVIF properties explorer**
View a device's ONVIF properties extensively (Device, Media, PTZ, etc.)
- **Focus meter**
Show the current status of the camera focus in numerical values on the screen to adjust camera focus more easily and accurately.

Overview









Viewer App. functions

- **HD/EX/3G-SDI Input**
Support HD/EX/3G-SDI Input. Please refer to page 59 for more information on the supported resolution.
- **HD Analog, CVBS Input**
Support AHD/TVI/CVI Input. Please refer to page 59 for more information on the supported resolution.
- **HDMI Input & Output**
HDMI Input through HDMI cable and video output of this test monitor in 1080p 60Hz through HDMI output port.
- **RS-485 Communication**
Data transmission in RS-485 Tx. mode and data analysis in RS-485 Rx. mode.
- **RS-485 Analysis**
RS-485 data analysis in analysis mode
- **PTZ /OSD Settings**
Camera OSD menu setting and PTZ (Pan/Tilt/Zoom) function implementation by RS-485 communication.
- **PoC Output (Optional)**
PoC output up to 10W for the PoC camera operation.
- **Level meter (SDI / AHD / TVI / CVI / CVBS Support)**
Show the current status of the input signal in numerical values on the screen. This function is especially useful when any problem occurs in your system such as cables and it must be figured out.
- **Focus meter (SDI / AHD / TVI / CVI / CVBS Support)**
Show the current status of the camera focus in numerical values on the screen to adjust camera focus more easily and accurately.
- **CRC Error count (SDI Support)**
Built-in CRC error count function to check data loss transmitted through cables.
- **Video recording & Snapshot**
Storage capacity extension possible by mounting Micro SD card additionally. It is available to save the recorded video or captured image into Micro SD card.
- **Audio playback**
Playback of the recorded HDMI audio signal.
- **UTC (Up The Coaxial / AHD, TVI, CVI, CVBS Support)**
Camera OSD menu setting and PTZ (Pan/Tilt/Zoom) function implementation through a coaxial cable without wiring data lines by UTC function.

Overview

Product Components

- Please check if the following components are all included in your package when you receive this item.

Item	Name	Description
	IP Multifunctional Test Monitor	Charge the battery prior to its use. It may be discharged at the time of delivery.
	Exclusive bag with strap	Keep the test monitor in this bag for its storage or use. Otherwise, the LCD and main body may be scratched.
	Exclusive Charger	This charger is exclusive for this test monitor. If any other charger is used to recharge this device, it may generate some problems.
	Power output leads	Use this cable for DC12V power output from this test monitor through DC12V IN/OUT port.
	Coaxial Cable	Use this cable for SDI or Analog video signal input.
	Power input leads	Use this cable for DC power input.
	User's Manual	The manual is provided in a 64-page booklet and a separate quick guide is provided.
	USB LAN Card	Wi-Fi is available to use only when the USB LAN card is mounted on this test monitor.

Product Parts and Descriptions

Top Interface

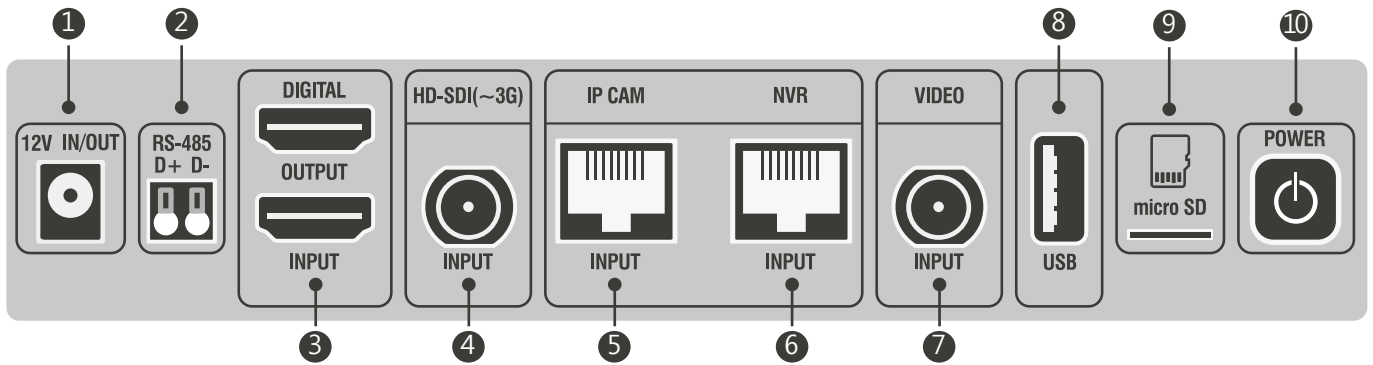

No.	Name	Description
①	Power Connector	The exclusive adapter included in this package is only allowed to recharge this test monitor. DC12V power supply for camera operation is also available through this port by using the power output lead. There are 5,680 mAh Li-Polymer batteries built in this monitor.
②	RS-485 Communication	Camera PTZ and OSD menu settings are available by RS-485 communication function. In addition, data reception and analysis are possible in RS-485 Rx. and Analysis modes.
③	HDMI Input/Output	HDMI input up to 1080p 60Hz resolution is possible, which is received from external devices such as NVR or DVR. HDMI output in 1080p 60Hz resolution is also possible.
④	HD-SDI(~3G) Input	HD/EX/3G-SDI video input is available and it can supply PoC (Power over Coax) to PoC camera. (PoC is optional)
⑤	IP Camera Connector (RJ-45)	This test monitor can connect a network camera directly or via a Hub/Switch. Also, it can supply PoE to a PoE camera.
⑥	NVR Connector (RJ-45)	PoE voltage test is available through this port.
⑦	Video Input	AHD, TVI, CVI or CVBS input is available through this port and camera PTZ and OSD menu settings are also easily implemented by UTC function.
⑧	USB Terminal	This test monitor supports USB 2.0 and supplies 5V power through this USB port. Wi-Fi is available to use only when the USB LAN card is mounted on this test monitor
⑨	Micro SD Card Slot	Standard Micro SD card can be mounted onto this test monitor and recorded video can be saved on it. Also, it can be used for data transfer.
⑩	Power Switch	You can turn on/off this test monitor by pressing this power switch for around three seconds, or set it to sleep mode by pressing this button for a second. The batteries can be saved due to this sleep mode function(Automatically power off after 10 minutes in its sleep mode)

Product Parts and Descriptions

Front Interface



No.	Name	Description
①	Touch Screen	IPS 7 inch TFT LCD panel in 1280x800 high resolution with tempered glass is applied. In addition, optical bonding is applied for outdoor environment and the fingerprint can be removed easily by applying the anti-fingerprint coating to this test monitor.
②	D-Pad (Directional Keys)	These keys are for adjusting directions (Up/Down/Left/Right/SET)
③	Mode button	This button is for opening the menu in the App. In the Viewer App., it can be used to switch to PTZ or OSD mode.
④	Home button	This button is for going to the Home screen. However, in this case, the App. running just before turning to Home screen is still ongoing.
⑤	Menu button	This button is for opening the menu in the Viewer App. or IP App.
⑥	Back button	This button is for terminating an App. during operation or returning to the previous page. If you terminate the App. during PoE or PoC, the power supply will be stopped.

Product Parts and Descriptions

Bottom Navigation and Tool Bar



No.	Name	Description
①	Back button	This button is for terminating an App. during operation or returning to the previous page.
②	Home button	This button is for going to the Home screen. However, in this case, the App. running just before turning to the Home screen is still ongoing.
③	Multi window	Multi window is for showing the currently active Apps.
④	Screen Shot	Take a screen shot of the current screen.
⑤	Audio	Adjust the audio volume.
⑥	Menu button	This button is for opening the menu in Viewer App. or IP App.

Product Parts and Descriptions

Backside Interface



No.	Name	Description
①	Monitor Stand	Test monitor stand for convenient monitoring. Adjust the angle of this test monitor.
②	Speaker	Dual speakers are mounted. Adjust volume.

Connection Diagram

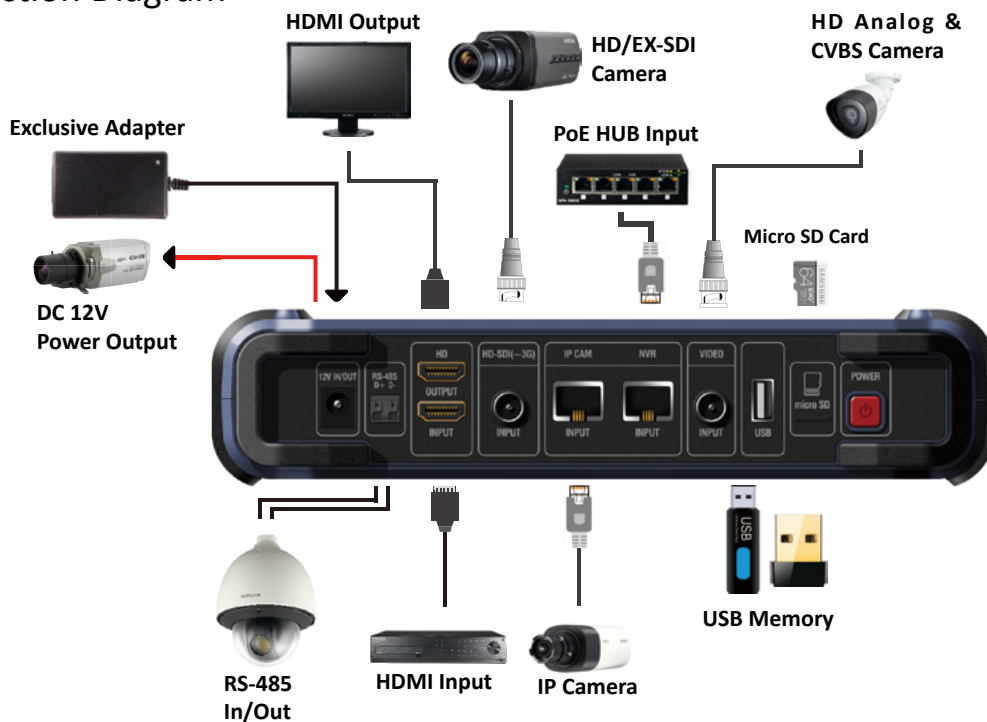

Product Functions

Launcher

- The following launcher screen will be shown once this test monitor is turned on.



No.	Name	Description
①	IP Camera App.	This App. is for IP video. Tap the icon to open the IP App.
②	SDI Camera App.	This App. is for HD/EX/3G-SDI Video. Tap the icon to open the SDI Viewer App.
③	HDMI App.	This App. is for HDMI Video. Tap the icon to open the HDMI Viewer App.
④	AHD Camera App.	This App. is for AHD Video. Tap the icon to open the AHD Viewer App.
⑤	TVI Camera App.	This App. is for TVI Video. Tap the icon to open the TVI Viewer App.
⑥	CVI Camera App.	This App. is for CVI Video. Tap the icon to open the CVI Viewer App.
⑦	CVBS Camera App.	This App. is for CVBS Video. Tap the icon to open the CVBS Viewer App.
⑧	My Apps	Show all installed Apps.

IP App. Functions

IP Camera Connection and Settings



Launcher page

- ① Select IP Camera App. to connect a network camera.

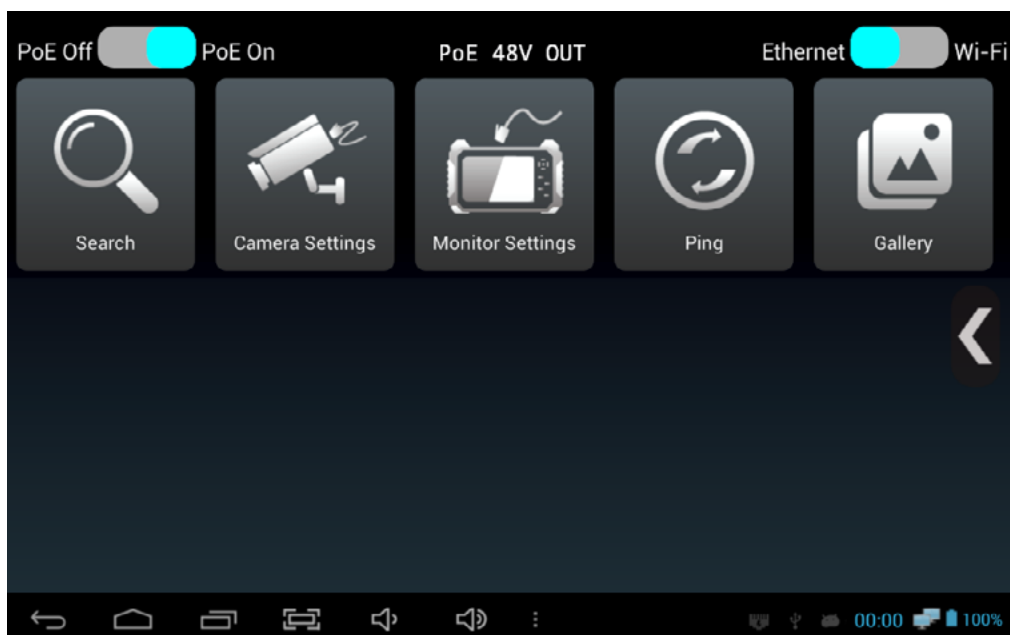

IP App. Home page

- ② The IP Camera App. has various functions such as IP search, camera settings, monitor settings, ping test, gallery, etc. If you connect an IP camera by LAN directly, please go to page 18. If you connect an IP camera by DHCP, please go to page 20.

IP App. Functions

IP Camera Connection by LAN

- This is for connecting an IP camera to the monitor by LAN directly without a DHCP server or a router.
- Change the monitor IP address to connect an IP camera.

1) When an IP camera is set with the DHCP or default IP address



Monitor IP Settings Page

- ① Tap the Monitor Settings icon in the IP App. main page to see the above page.
 - **'Use Ethernet' on the top of this page shall be marked all the time.**
- ② Select 'Advanced Configure' at the bottom of this page to open the monitor IP setting page.

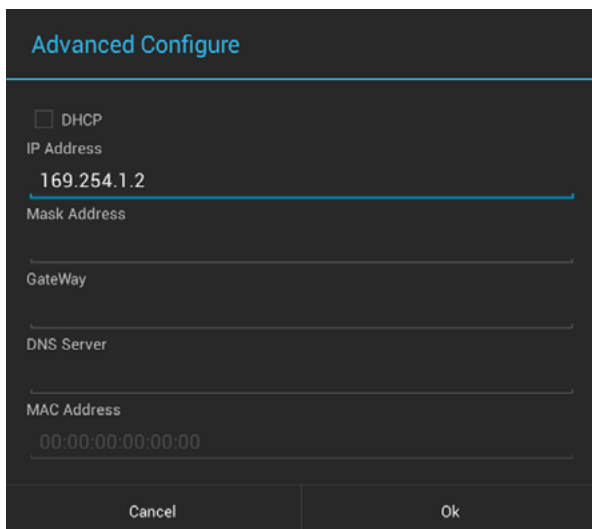

! Cautions for IP address settings

- The cameras discovered when entering 169.254.1.2 use a link-local address. Otherwise, please search a camera after entering the same IP address range of the camera.
- If nothing is discovered with the two IP addresses mentioned above, please reset the camera to factory defaults and try it again.
- DHCP is enabled when the monitor is connected to a router or a server.

- ③ Enter 169.254.1.2 in the IP Address, do not enter anything in the Mask Address, Gateway, DNS server and press OK. Then, all of the settings will be saved.
- ④ Move to the IP App. main page by pressing the back button or tapping the back (←) icon at the bottom of the screen.

IP App. Functions

2) When connecting an IP camera manually (When you know the camera IP address)



Monitor IP Settings Page

- ① Tap the Monitor Settings icon in the IP App. main page to see the above page.
 - **'Use Ethernet' on the top of this page shall be marked all the time.**
- ② Select 'Advanced Configure' at the bottom of this page to open the monitor IP setting page.

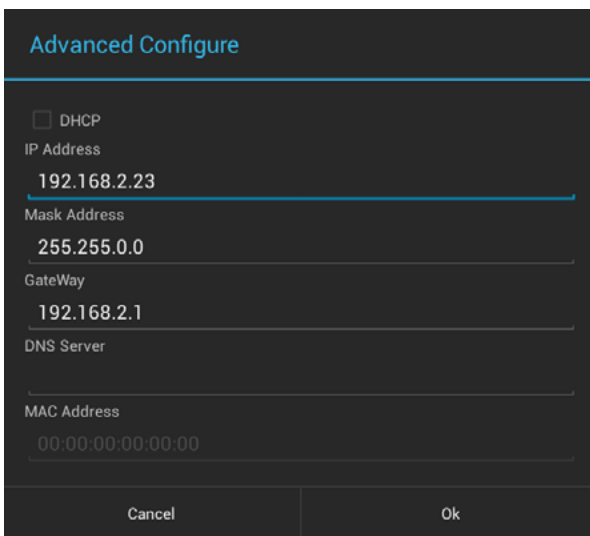

! Cautions for IP address settings

- When connecting an IP camera manually, please change the monitor IP address to the same range of the camera IP address. Otherwise, the camera will not be discovered and connected.
- If the monitor and an IP camera have different IP address ranges, the camera will not be discovered. If you do not remember the camera IP address, please reset it to factory defaults and go to page 18.
- DHCP is enabled when the monitor is connected to a router or a server.

- ③ Enter the same values in the IP Address except for the last value as the connected IP camera's IP address.
e.g.) Camera IP Address: 192.168.2.120, Monitor IP Address: 192.168.2.33
- ④ Enter 255.255.0.0 in the Mask Address, enter the same values of the IP camera address in the Gateway after changing the last value to 1, and press OK. Then, all of the settings will be saved.
e.g.) IP Address: 192.168.2.33, Gateway: 192.168.2.1
- ⑤ Move to the IP App. main page by pressing the back button or tapping the back (←) icon at the bottom of the screen.

IP App. Functions

IP Camera Connection by a DHCP server

- This is for connecting an IP camera to the monitor when a DHCP server or a router is connected and it assigns an IP address to the camera and monitor automatically.

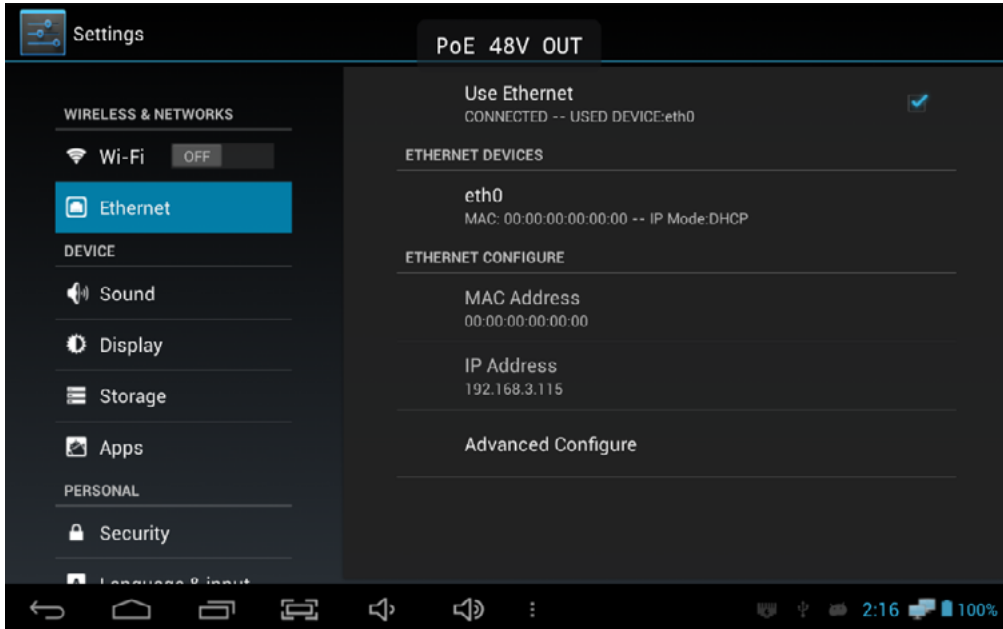

Monitor IP Settings Page

- ① Tap the Monitor Settings icon in the IP App. main page to see the above page.
 - **'Use Ethernet' on the top of this page shall be marked all the time.**
- ② Select 'Advanced Configure' at the bottom of this page to open the monitor IP setting page.

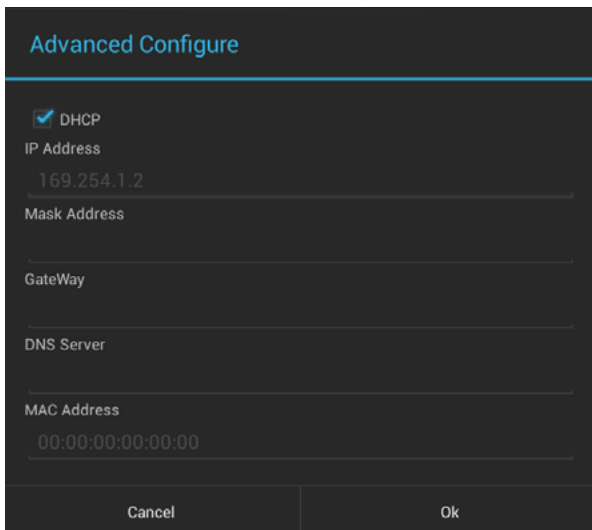

! Cautions for IP address settings

- When a DHCP server is configured, it assigns an IP address to the monitor and an IP camera.
- When the camera IP address is set manually, the camera will not be discovered and connected.
- This test monitor does not assign an IP address to a camera. A DHCP server or a router should be configured.
- Do not enter IP Address, Mask Address and Gateway.

- ③ Mark DHCP and press OK. Then, all of the settings will be saved.
- ④ Move to the IP App. main page by pressing the back button or tapping the back (↶) icon at the bottom of the screen.

IP App. Functions

Checking items prior to the camera discovery and connection

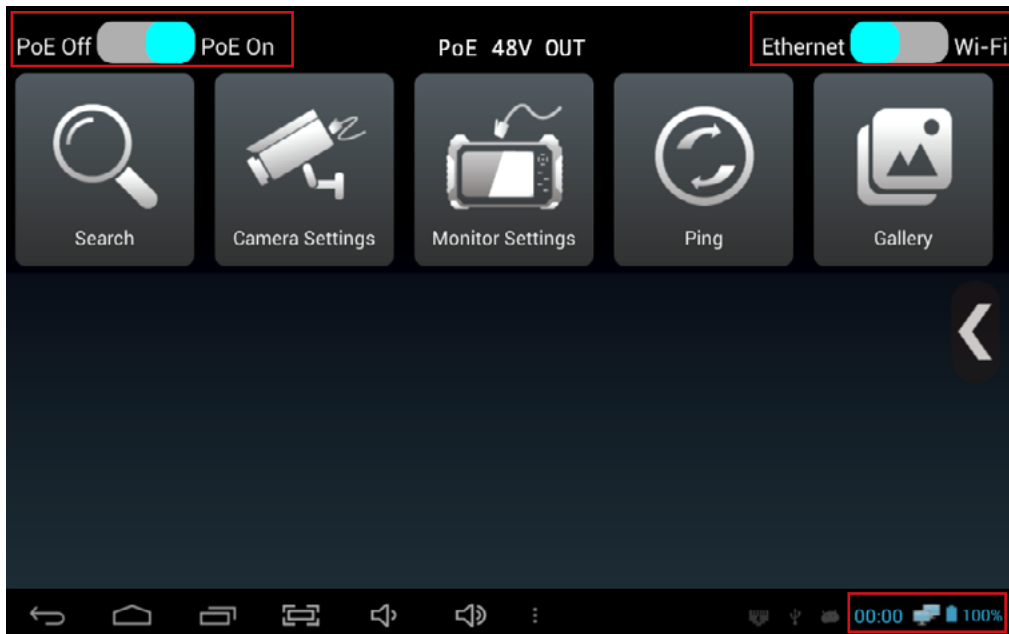

- Check the following items and move to the next step after completing the monitor settings.



IP App. Home Page (Main Page)

- STEP 1 :** Check the PoE status in the upper left corner. Turn on the PoE to supply PoE to your camera. If PoE is off, this monitor will not supply PoE to your camera.
- STEP 2 :** Check the Ethernet/Wi-Fi status in the upper right corner. Make sure to turn on Ethernet when connecting your camera with LAN cable and turn on Wi-Fi when connecting your camera wirelessly.
- STEP 3 :** Check the network connection status at the bottom right corner. The monitor icon  will be shown if the camera is connected after finishing monitor settings. No monitor icon means unstable network connection, so in this case, you must recheck the monitor settings and the previous steps mentioned above. If the monitor icon is still not shown even after rechecking all steps, pull out the LAN cable and connect it to this test monitor again.
- STEP 4 :** Check the LED status of the LAN port. If the network connection is normal, you will see green and orange LEDs on. If the green LED is off, the camera is still starting or there may be an error of communication. In case of using PoE, check whether or not the camera supports PoE.

Wireless connection :

The monitor settings are not required for wireless connection equipment. The connected router or server assigns IP to the camera automatically. For wireless connection, Wi-Fi icon  will be shown at the bottom right corner instead of the monitor one. .

IP App. Functions

IP Device Discovery

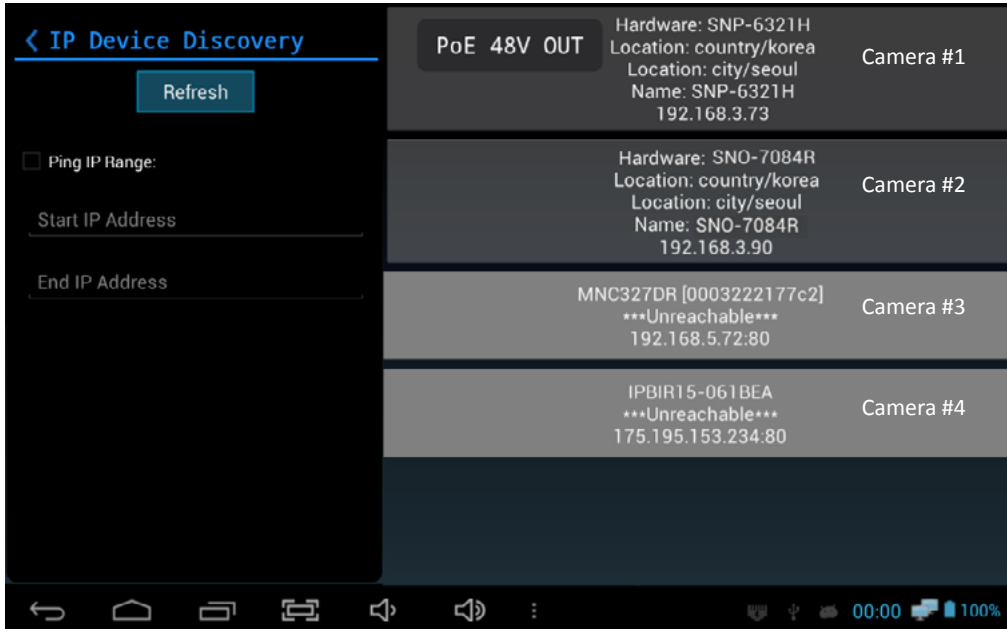

Search page

- ① Once you enter the Search from the IP App. main page, the discovered cameras will be displayed on the screen as shown in the above picture.
 - IP values depend on camera brand due to the different network settings of camera manufacturers. For example, four different addresses are shown in the above picture. When a discovered IP camera's address is in the same range of this monitor's IP, it will be shown in dark gray with the camera's hardware, location, name and IP address like #1 or #2 cameras in the above picture. However, in case of an IP camera having different range of the monitor's IP, it will be shown in light gray only with the camera's name and IP address like #3 or #4 cameras in the above picture.
 - In case of #1 and #2 cameras in the above picture, either of the cameras can be connected immediately because the current monitor IP is in the same range of these cameras' IP addresses. For #3 and #4 cameras, they will be also connected, but in this case, the monitor's IP address temporarily changes to match the IP camera's IP range.
e.g.) The IP address of #3 camera is 192.168.5.72. When this camera is selected, the monitor's IP address will temporarily be modified to the same IP range as the camera's IP, but not the exactly same address such as 192.168.5.73. The monitor's IP will be back to the original IP range once you pull out the connected IP camera from the monitor.
- ② Tap one of the discovered cameras to open the IP Camera Settings page.

! When the camera is not discovered

- Non-ONVIF conformant.
Non-ONVIF conformant cameras are not supported in discovery. These cameras can be connected manually by RTSP. RTSP address depends on camera manufacturer and can be found in the camera instructions.
- When using a wireless router.
When connecting a camera wirelessly, the network status must be changed to Wi-Fi. The router assigns IP to the camera automatically. (The method to assign IP depends on the connected router)

IP App. Functions

IP Camera Connection and Settings

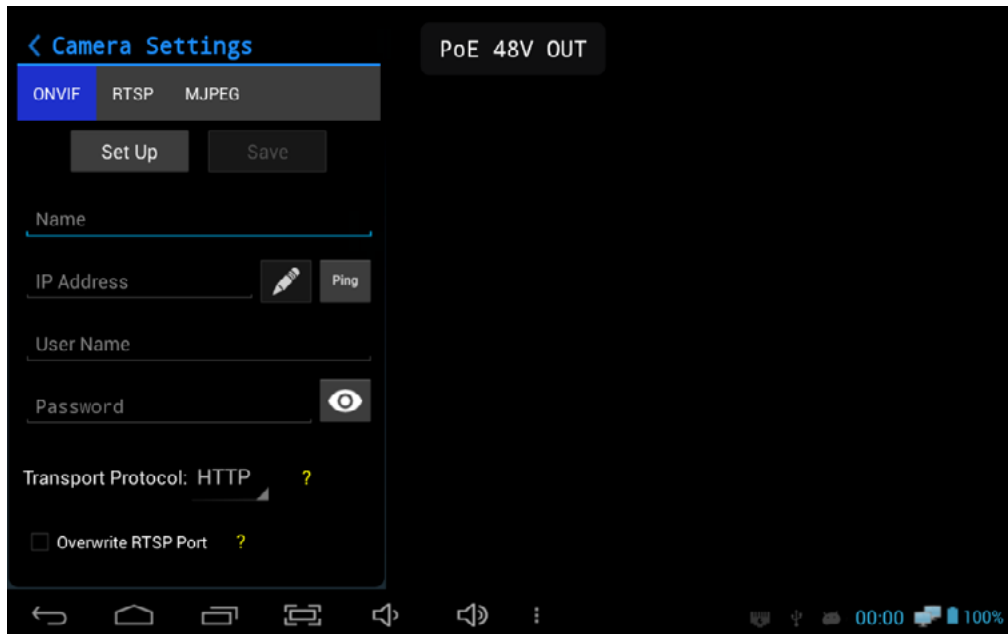

Camera settings page

- ① Once you select the Camera Settings icon or one of discovered cameras in the Search page, the camera setting screen is displayed.
- ② Enter any word such as the camera name or installed location to identify the camera in the Name field.
- ③ Enter the camera IP address in the IP address field. If one of the discovered cameras is selected, the IP address is filled automatically.
- ④ When the camera is selected, admin is entered as the user name. If you do not know the user name, reset the camera to its default factory setting and enter the default user name. The default user name depends on the manufacturer. You can find the default information in the camera instructions.
- ⑤ Enter the password in the Password field. If you do not know the password, reset the camera to its default factory setting and enter the default password. The default password of each camera is normally specified in the camera instructions.
- ⑥ For transport protocol and RTSP port overwrite, no need to change them now. Once all values are added, tap the Set Up button to test the camera.

! When the camera connection fails

- When the IP address is uncertain.
Tap the Ping button to check the IP address after entering the IP address. Ping will fail if the address is wrong. The IP range of the monitor and camera should be same as well.
- When you cannot remember the user name and password.
When you forgot the user name and password, reset the camera to its default factory setting and enter the user name and password set by the manufacturer.

IP App. Functions

- Once the camera is connected, the preview video will be displayed as shown in the following picture.

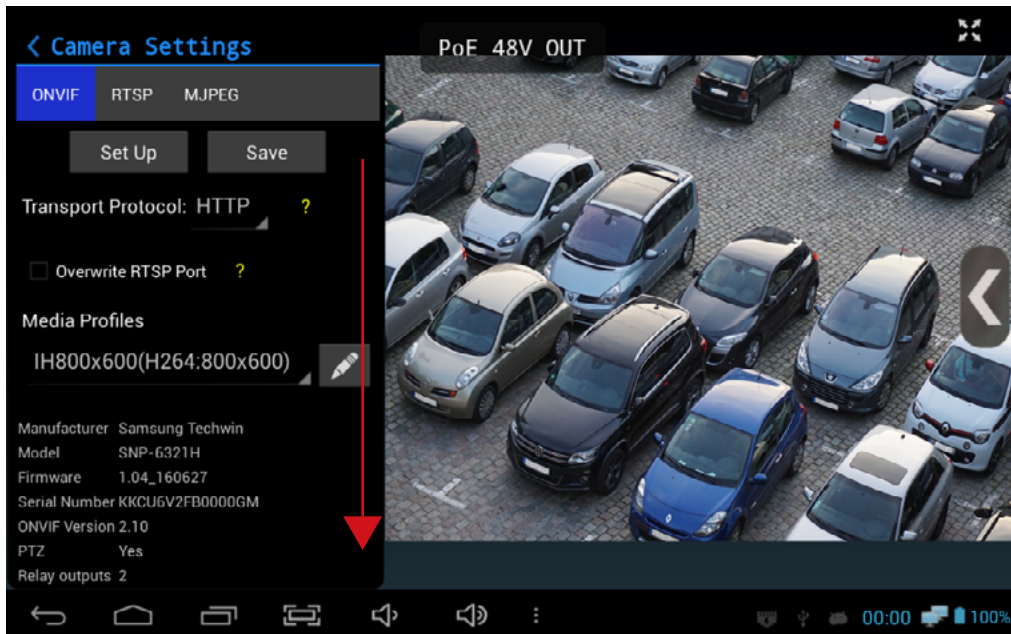

Camera Setting Page

- 7 Scroll-down the left setup panel after the camera is connected. you can modify the profile settings.
- 8 After completing all settings, press the Save button to save the configuration to the IP App. main page for future use if you choose so.
- 9 To watch the live video of the connected camera, press the Full Screen  at the right upper corner in the preview video mode.

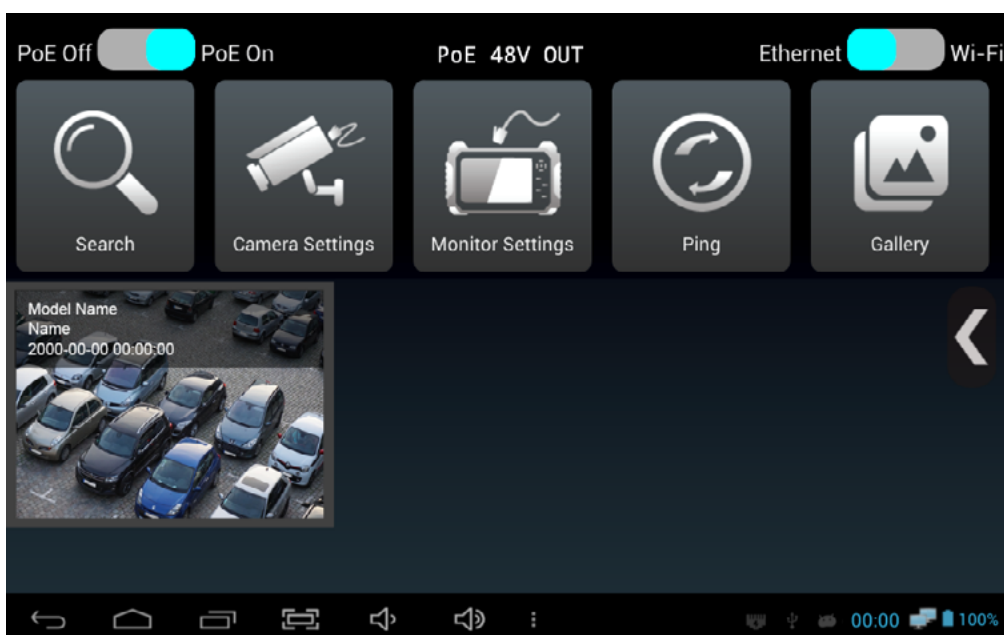

IP App. configuration

- 10 Tap the saved configuration of the camera on the IP App. main page to see the live video in full screen without the need camera search and settings.

IP App. Functions

Utilize Configuration

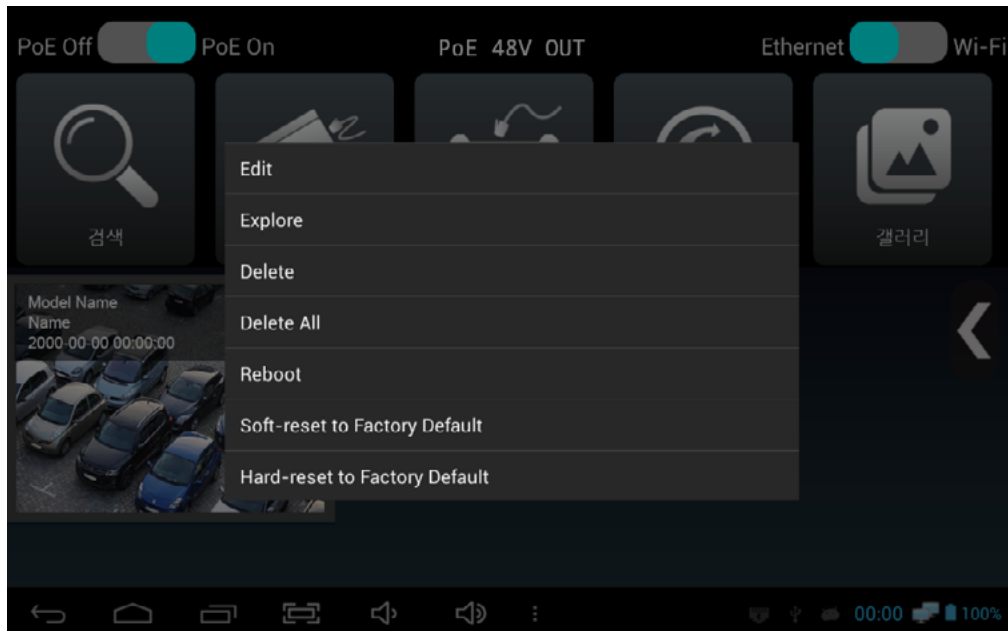

Configuration Menu Screen

- ① In the IP App. main page, press and hold the saved configuration or press the SET key to display a context menu.
- ② Select Edit to change the configuration and select Explore to check the information of the configured camera.
- ③ If the camera supports resets, it is possible to initialize the camera settings to have the factory default values.



! How to use the configuration effectively

- **When installing the same type of cameras**
All cameras have their default IP addresses. As the saved camera configuration includes the camera IP address, ID, password, etc., you can use it for the installation of the same type of cameras. However, the same type of the camera needs to be the default mode or it must have the same IP address range.
- **How to register the IP address used frequently for your installation**
After saving the configuration of the installed camera, you can export the saved configuration and make a configuration list per installed location. During maintenance, you can import the relevant configuration and check the camera connection status without any setup process.

IP App. Functions

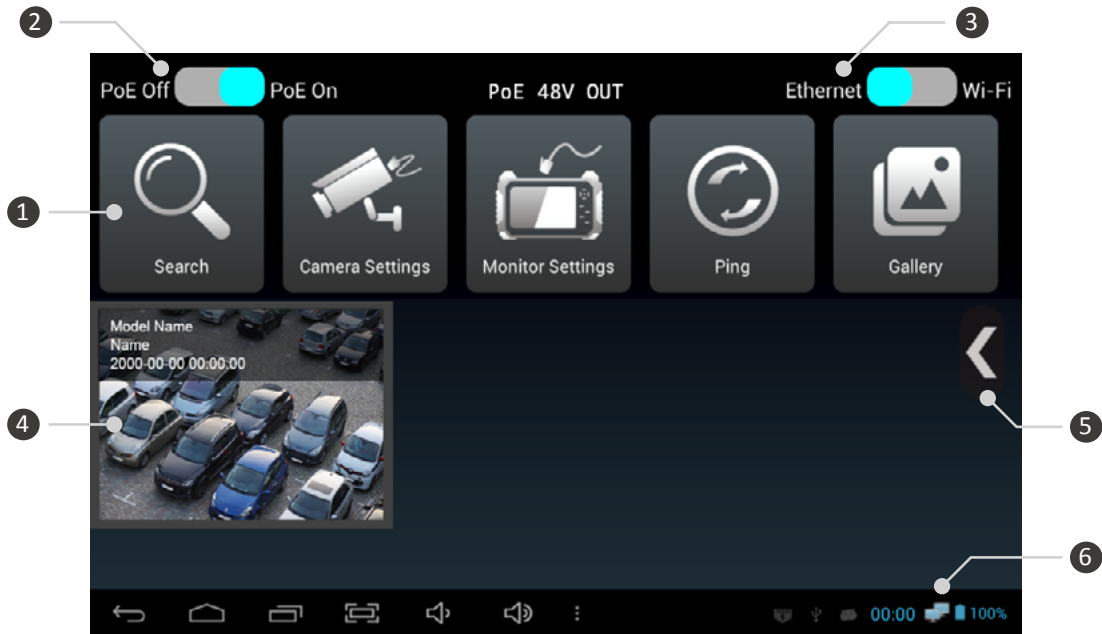
IP App. Main Page



No.	Name	Description
①	Action Menu Icon	There are Search, IP camera settings, Monitor settings, Ping test, Gallery icons as shown in the above picture.
②	PoE Setting	This is for turning on/off the PoE (Power over Ethernet) function. When the PoE function is on, this monitor supplies PoE to a connected IP camera from the built-in battery and depending on the camera's specifications, the monitor's battery can run down faster. When the PoE function is off, the monitor stops supplying PoE to the camera.
③	Network Type	This is for selecting the network type of this test monitor. Turn the Wi-Fi on when connecting the camera by using a wireless router. If not, turn the Ethernet on.
④	Saved Configuration List	Once you save the configuration of your camera in the camera setting page, a device tile will be added as shown in the above picture. For any camera with the same IP address and camera information as the saved configuration, you can check the video by selecting the relevant configuration without any setup process.
⑤	Menu of IP App. Main Page	This menu includes Sort Tiles, Settings, Help, Feedback and about functions.
⑥	Network Connection Status	If the network is set to Ethernet and the network is connected, the  monitor icon is displayed. The  icon is displayed when Wi-Fi is set.
⑦	PoE Voltage Check	When the PoE function is on in the PoE setting button, PoE 48V OUT will be shown on the top of the monitor screen. When the PoE function is off, it will show PoE OFF. The PoE voltage of the power supply unit connected to the NVR port. In case of an IP camera is connected to the CAM port, the power supply unit connected to the NVR port will supply power to the camera. You can tap and drag this voltage check sign to where you would like to put it on.

IP App. Functions

Menu in the IP App. Main Page

- In the IP App. main page, once you press the menu or mode key or touch menu icon , the menu bar will be shown as follows.

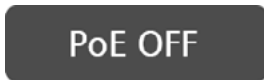

PoE OFF



PoE ON



PoE Voltage Check

- PoE OFF**
 - PoE function is OFF.
- PoE ON**
 - When turning the PoE function on, PoE 48V OUT will be shown on the top of the screen.
 - This monitor supplies PoE from its built-in battery.
- PoE Voltage Check**
 - When any power supply unit is connected to the NVR port, the voltage of the PoE supplied from the device will be shown on the top of the screen.
 - Supply PoE to a device connected to the CAM port from the power supply unit connected to the NVR port.

Menu in the IP App. Main Page

- In the IP App. main page, once you press the menu or mode key or touch menu icon , the menu bar will be shown as follows.

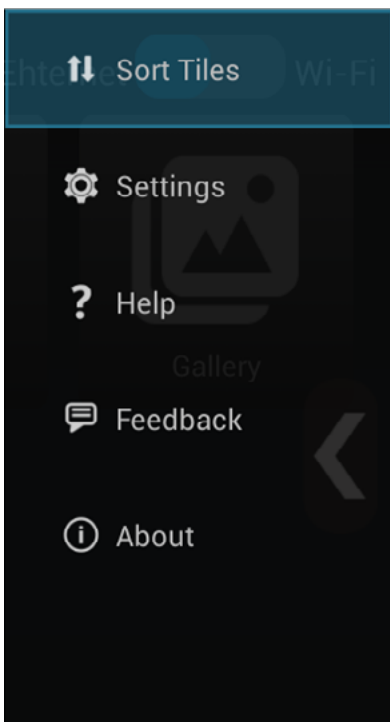

- Sort Tiles**
 - You can rearrange the order of saved configurations.
- Settings**
 - Import/export the device configuration.
 - Choose whether to display the time and model of the saved configuration on the device.
 - Select the location for saving recorded or captured images.
- Help**
 - You can find the instructions of this test monitor.
- Feedback**
 - You can send an e-mail when there is anything to be improved.
 - This function is available for use only when this monitor is connected to the Internet.
- About**
 - You can see the version and copyright of this test monitor.

Configuration Rearrangement

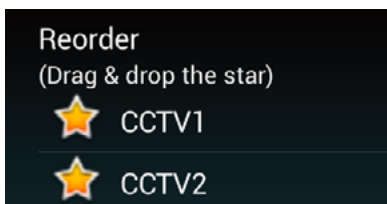

- All saved configurations will be shown.
- Drag any of the star-shaped icons to where you want.

IP App. Functions

IP Device Search

- Tap the search icon to start camera discovery as shown below.
- All IP cameras will be searched automatically when entering this screen.



No.	Name	Description
①	Refresh	Touch this button to try the search again.
②	Ping IP Range	This is a method to search IP devices by using Ping and available for use after entering the Start IP address and the End IP address. The greater the search range is, the longer it may take to search the IP devices.
③	Search Results	The discovered IP cameras are displayed with their names and IP addresses. The discovered information depends on the camera's brand.

! When the camera is not searched

- **When using unsupported protocol.**
Non-ONVIF cameras may not be discovered. These cameras can be connected manually by RTSP. The RTSP address depends on the camera brand and can be found in the camera instructions.
- **When using a wireless router.**
When connecting the camera wirelessly, the network type must be changed to Wi-Fi. The router assigns IP to the camera automatically via DHCP.
- **When the IP address is changed manually.**
When changing IP address of the camera randomly, the camera may not be discovered. If you have forgot or lost the camera IP address, initialize the camera manually to its factory default.

IP App. Functions

Camera Settings

- Tap the Camera Settings icon in the IP App. main page to test an IP camera.
- Selecting one of the discovered camera in the Search page also opens Camera Settings as following.

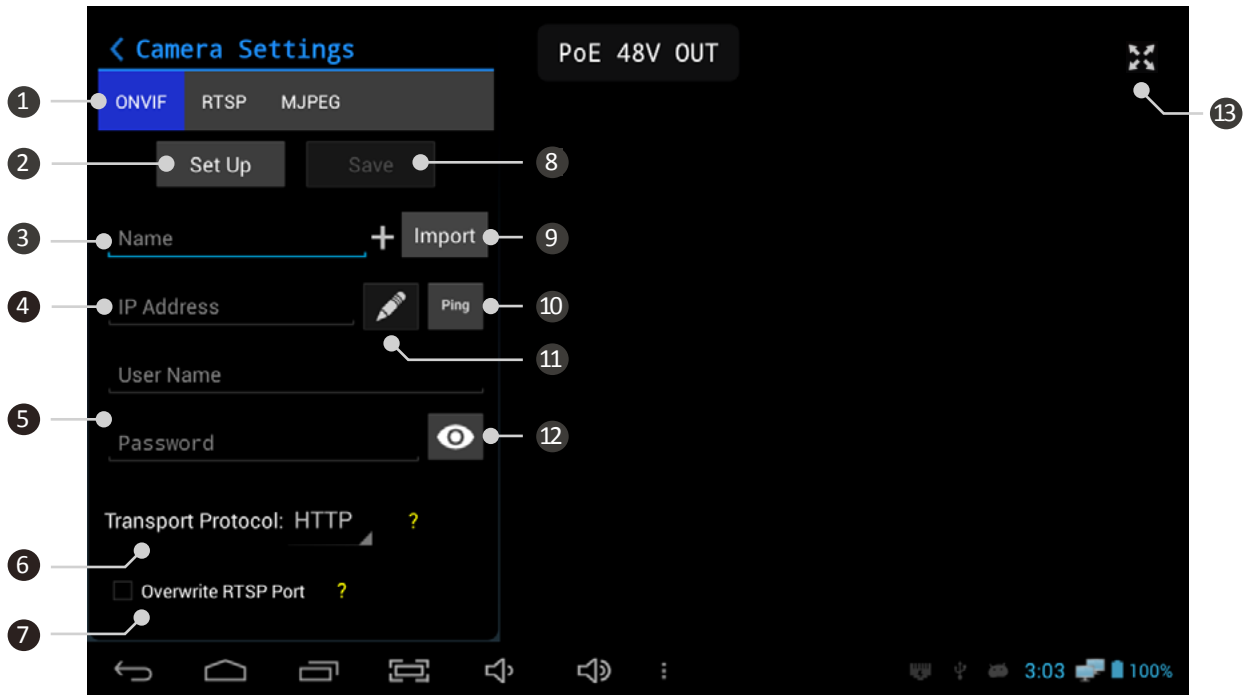

No.	Name	Description
①	Device Type	Select your device type such as ONVIF, RTSP and MJPEG.
②	Set up	Connect the camera with the setting information entered below. Press this button after completing the below setting information.
③	Camera Name	Enter a camera name as you wish.
④	Camera IP Address	Enter the IP camera address. If you are not sure about the IP address, you can check the connection status by using the Ping button on the right side.
⑤	User Name / Password	Enter the user name and password of the credential used to connect the camera.
⑥	Transport Protocol	Select a transport protocol between HTTP, TCP and UDP. HTTP is recommended. If HTTP is not supported, this test monitor finds the appropriate protocol automatically.
⑦	Overwrite RTSP Port	Specify the RTSP port value. This is not needed usually. It is useful only under certain circumstances when port forwarding is involved.
⑧	Save	Save the configuration to the main page of the IP App.
⑨	Import	Enabled only when there are saved configurations. Import one of the saved configurations.
⑩	Ping Test	Ping the connected camera and check the connection status.
⑪	Network Edit	Modify the network settings of the connected camera.
⑫	View Password	Display the entered password.
⑬	Full screen	Enabled only when the camera is connected. Check the video in full screen.

IP App. Functions

Camera Network Settings

- This function is available only when the camera is connected.
- Tap the Network Setting icon  to enter the following page.

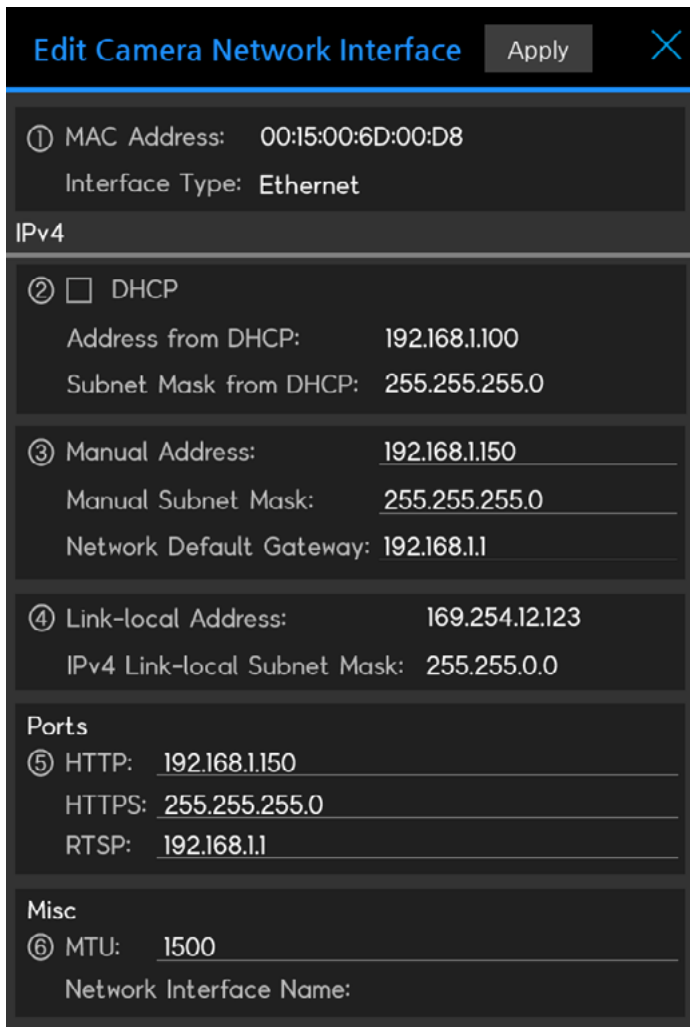

- ① Camera Network Information
 - MAC Address is fixed for each camera.
 - Interface Type represents the current network type of the connected camera.
- ② DHCP Settings
 - Check the DHCP box to enable DHCP.
 - The automatically assigned address by a DHCP server will be shown in the below address field.
- ③ Manual IP Settings
 - You can change the camera IP address, Subnet Mask and/or Gateway.
- ④ Link-local Address
 - You can check the link-local address of the camera.
 - Link-local address is not available for modification.
- ⑤ Camera Ports
 - You can check the ports used for the camera's HTTP, HTTPS and RTSP servers.
- ⑥ Misc.
 - MTU: You can set the packet size for the transmission in network. This may be useful to accommodate some routers to achieve the best data rate.

! When the error window is displayed.

The operation depends on camera network specifications as each manufacturer has different specifications.



- When the IP address is not changed after modification.
The IP address will be changed once you reboot the camera.
- When an error window is displayed.
The IP address will be changed once you reboot the camera.

IP App. Functions

■ Edit Media Profile

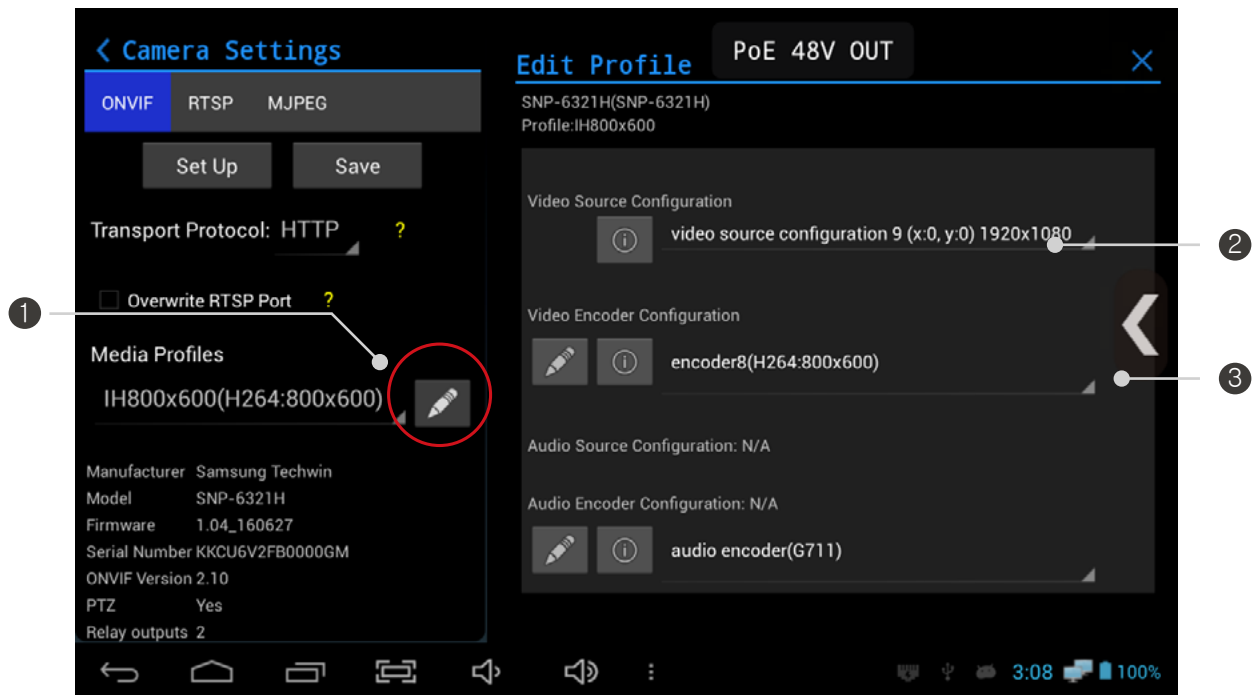
- Once a camera is connected, you can edit the media profile.
- Tap the  profile edit icon to see the following image.



No.	Name	Description
①	Profile Edit Settings	You can set its resolution, encoding type, video quality through video encoder and also you can set bit rate, encoding type, sample rate through audio encoder.
②	View details	Tap  icon to check its source and encoder's contents in details.
③	Encoder Edit Settings	Tap the  to change its video and audio encoders' configurations. In case of not supporting audio, it will be indicated as N/A.

IP App. Functions

Main page

- If tapping the  at the top right of the screen after a camera is connected, the window will be shown as the following image.

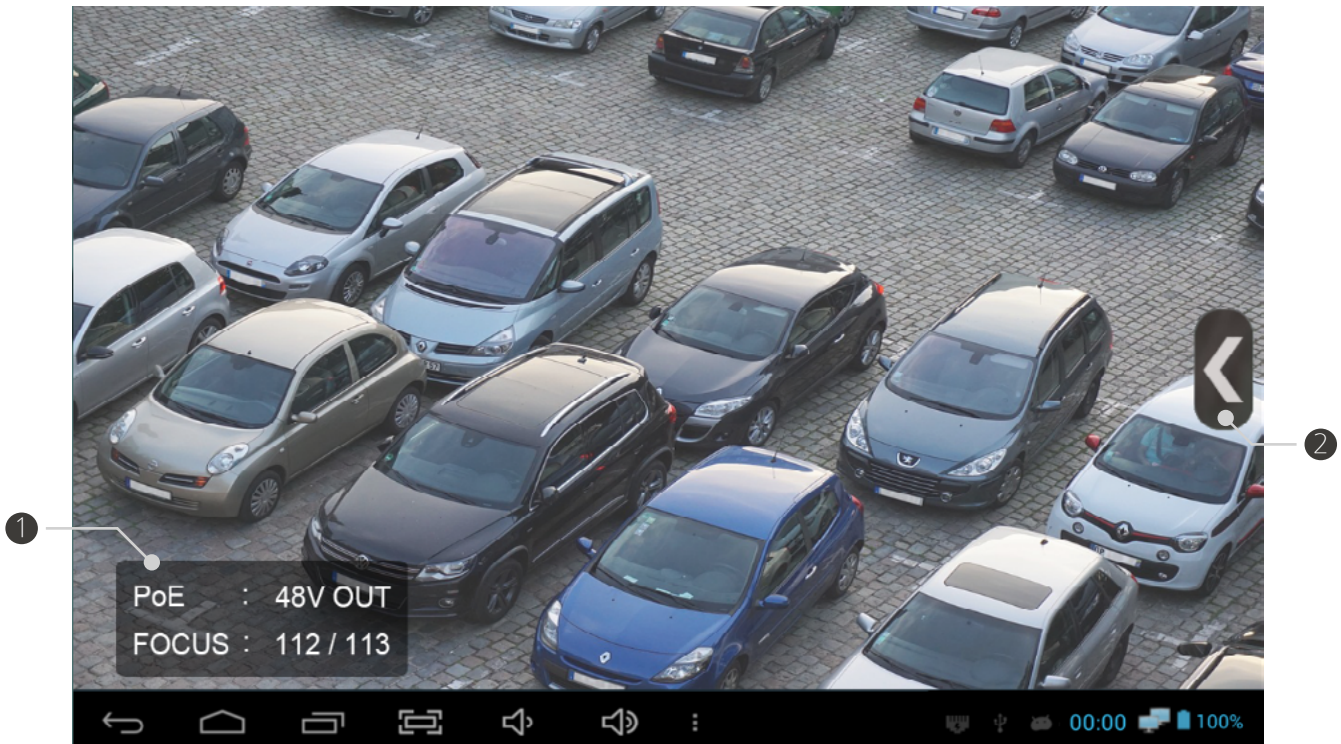

No.	Name	Description
①	Focus Meter Function	The PoE voltage status sign on the top will move to the left bottom in video full screen mode. The focus meter function is to adjust a camera's focus more easily and accurately by indicating the optimum and current focus status in numerical values in real time. The focus value is between 255 and 0. Please refer to the page 47 for more information.
②	Video Menu Bar	This menu includes aspect ratio settings (Full/Original images), recording, capturing, mute, presets, digital PTZ settings, gallery(playback), video information and e-mail log for debugging, etc.

IP App. Functions

Live video menu bar

- In the IP App. video page, you tap the menu or mode key or touch the  menu icon to show the following menu bar.

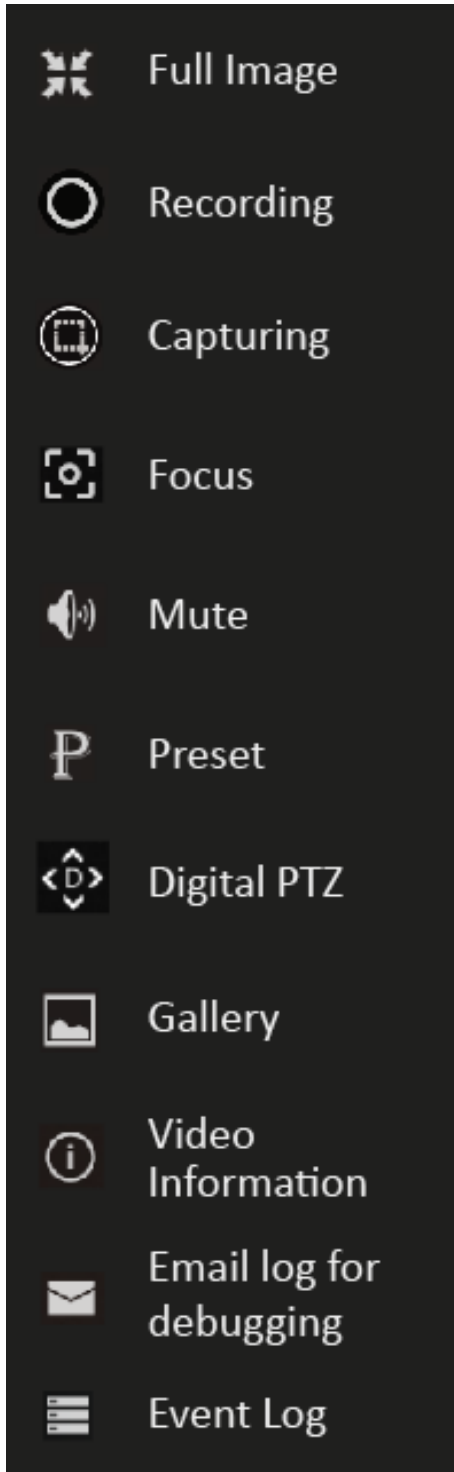

- ① Full Image / Full Screen**
 - In the full image mode, the full video is displayed. This may result in empty spaces that are not occupied by the video.
 - In the full screen mode, the video is scaled to fill the monitor screen completely while maintaining its aspect ratio. This may result in cropping the video.
- ② Recording**
 - It is for recording the input video.
 - The video recording is available up to 5 minutes.
 - Make sure to check the cautions for recording
- ③ Capturing**
 - It is available to capture the input video.
 - Make sure to check the cautions for capturing
- ④ Focus**
 - It is available to adjust the Hanwha Techwin's zoom lens camera focus
 - It is not available to adjust the conventional lens camera focus.
- ⑤ Mute**
 - Mute mode is available for audio (G.711).
 - The audio depends on the RTSP stream's support.
- ⑥ Presets**
 - This function is enabled only for cameras supporting presets.
 - Preset saved in the camera is available for use.
- ⑦ Digital PTZ**
 - This function is enabled only for Digital PTZ cameras.
 - Digital Zoom function is available for use.
- ⑧ Gallery**
 - Recorded or captured images are stored here.
- ⑨ Video Information**
 - You can check the information of the input video in real time.
- ⑩ Email log for debugging**
 - You can send the errors generated during the product operation by e-mail.
 - This function is available only during Wi-Fi.
- ⑪ Event Log**
 - You can check the camera connection log.

IP App. Functions

Video Recording

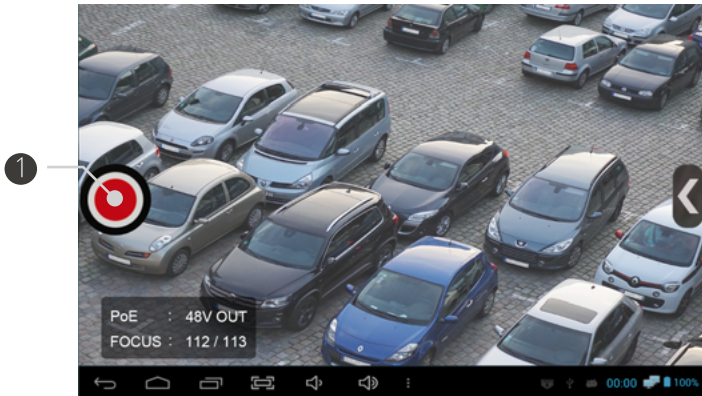

- ① Recording Start Button
 - Start recording by tapping  button.

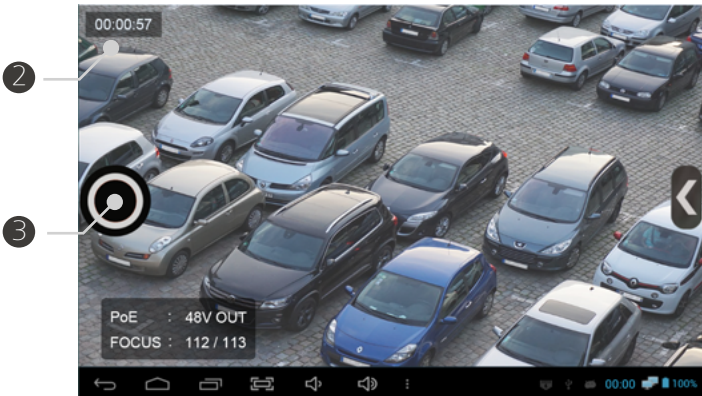

- ② Recording Status Display
 - The recording time is displayed.
 - The recording is available up to 5 minutes.

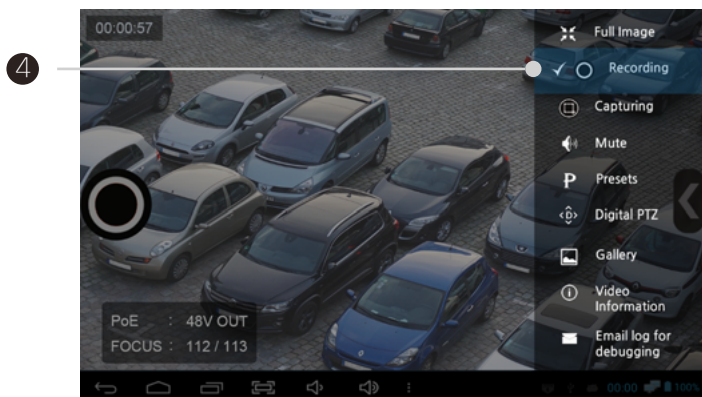

- ③ Recording End Button
 - End recording and save the recorded file by tapping  button.

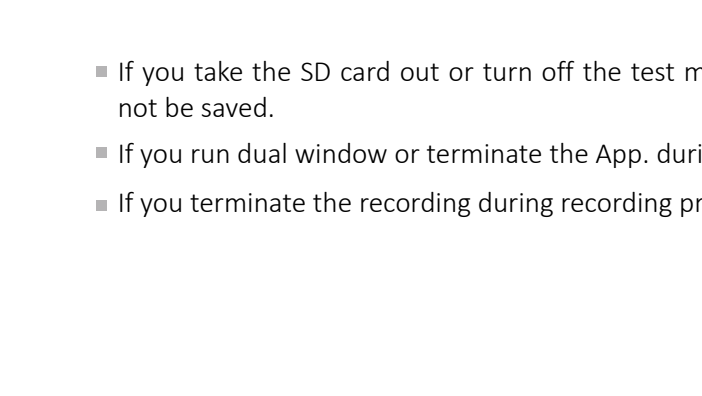

- ④ Recording Function Termination
 - Select the Recording in the menu bar. Then, the "V" mark will be removed and the recording function will be terminated.
 - You can also terminate the recording function by pressing the Back key.

! Cautions for recording

- Recording specifications depend on each camera manufacturer.
- Change the media file saving location from Internal to SD Card, which is in the Settings of the menu bar in the IP App. main page. Then, the recorded video will be saved in the SD card.
- The recorded video is saved in MP4 format.
- The maximum recording time is 5 minutes.
- Check the storage space prior to continuous recording.

- If you take the SD card out or turn off the test monitor during recording, the recorded video file will not be saved.
- If you run dual window or terminate the App. during recording, the recorded file will not be saved.
- If you terminate the recording during recording preparation, the file will not be saved.

IP App. Functions

Snapshot Capturing

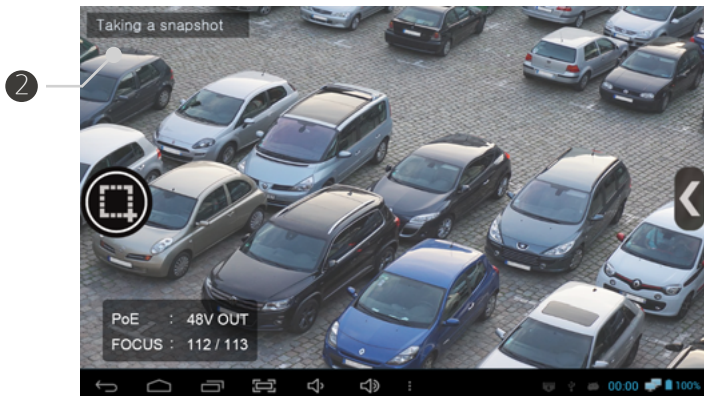
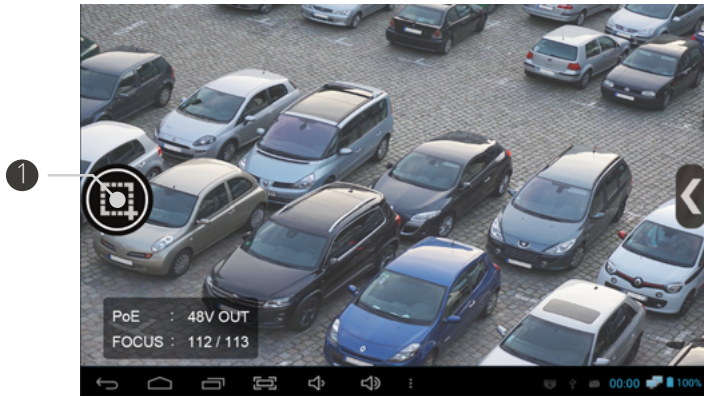

- ① Capturing Start Button
 - Start capturing by tapping  button.
- ② Capturing Status Display
 - Display the capturing status.
- ③ Capturing Function Termination
 - Select the Capturing in the menu bar. Then, the “v” mark will be removed and the capturing function will be terminated.
 - Press the BACK key to terminate the capturing function.

! Cautions for capturing

- Capturing specifications depend on each camera manufacturer.
- Change the media file saving location from Internal to SD Card, which is in the Settings of the menu bar in the IP App. main page. Then, the captured image will be saved in the SD card.
- The captured image is saved in JPG format.
- If you tap the capture button continuously, the image may not be saved.

IP App. Functions

Audio Input

- This monitor supports AAC (Advanced Audio Coding), G.711 μ -Law, G.711 A-law codecs.
- If the camera supports audio, the sound will come out through the monitor's speaker. Please note that a profile may not include audio even when the camera supports audio.
- You can control the speaker output by using the mute function.

Video Output Codec Change

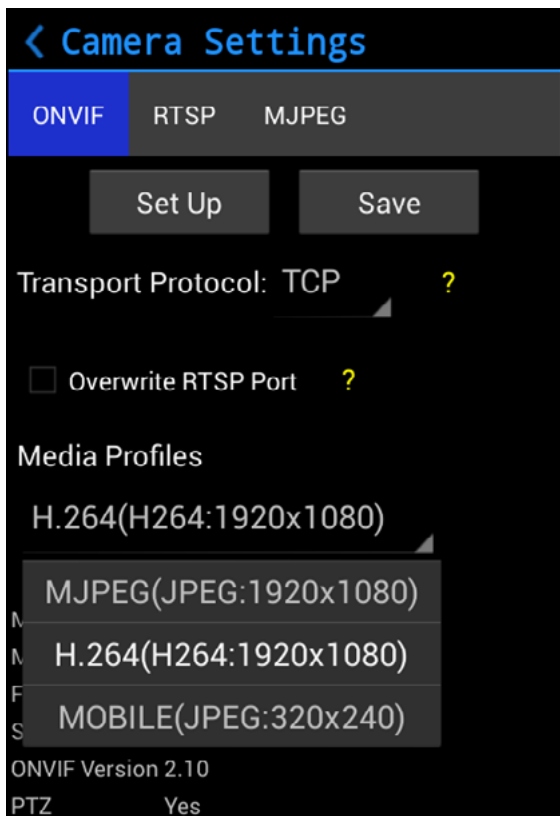

- This test monitor supports H.264 and JPEG codecs.
- You can select the video codec by choosing a Media Profile of the IP camera setting page accordingly.
- When saving the configuration or turning to full screen after selecting a profile, the new profile will be applied.

! Cautions for changing codecs

- Codec specifications depend on each camera manufacturer.
- H.265 is not supported by ONVIF currently.
- MPEG4 is not supported.
- JPEG over 3Mega is not supported, but supported only for certain models.
- Multicast method is not supported.

IP App. Functions

■ Pan/Tilt Functions



- Opto-mechanical pan/tilt functions are available for PTZ cameras only
- Pan/tilt the camera by touching the screen and wiping it.
- Pan/tilt functions are available by both touching the screen and using the arrow keys.
- The pan/tilt speed depends on each camera brand when operating by the arrow keys.

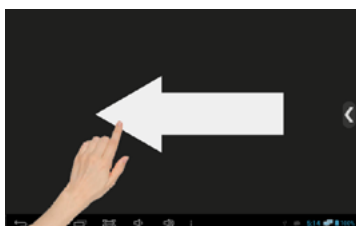

- Swipe left from right
- Press the right arrow key



- Swipe up from down
- Press the down arrow key

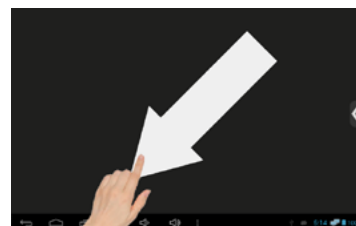

- Swipe diagonally
- Unavailable to operate it by arrow keys.

IP App. Functions

Zoom Function

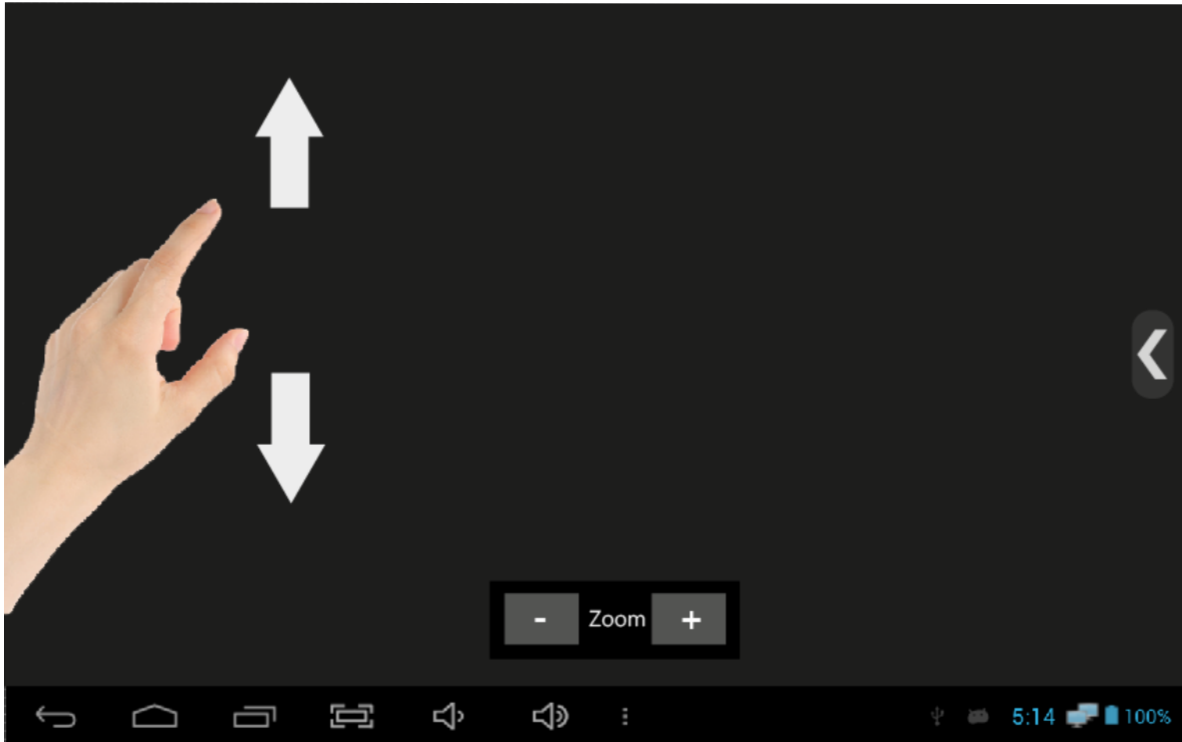

- If the camera supports opto-mechanical PTZ, enable the Digital PTZ first to use Digital Zoom function. Otherwise, opto-mechanical Zoom will be applied.
- Zoom out/in the video screen by your fingers.
- Pinch two or more fingers together to zoom out.
- Stretch two or more fingers apart to zoom in.
- Zoom out/in available by pressing -/+ of the zoom bar at the bottom of the screen.

IP App. Functions

Presets

- This function is enabled only for cameras supporting presets.
- Some characters may not be allowed in preset names by some camera brands.

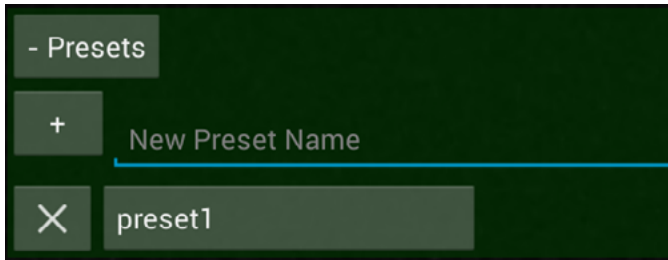

- Presets function shows a list of defined presets.
- Type the Preset Name and press the + button to add a preset.
- Select a preset from the list to move the camera to the preset position.

Video Information

- Select the Video Information from the video menu bar. It will be shown as follows.



- | | |
|------------------------------------|--------------------------------|
| ① Network Video Transmitter | ⑩ RTP packets lost (Real-time) |
| ② NVT type | ⑪ Frame rate (Real-time) |
| ③ Camera model | ⑫ Audio codec (If available) |
| ④ Media profile | ⑬ ONVIF port |
| ⑤ Video resolution | ⑭ RTSP port |
| ⑥ Video encoding | ⑮ Data rate (Real-time) |
| ⑦ Transport protocol | |
| ⑧ H.264 profile level | |
| ⑨ RTP packets received (Real-time) | |

IP App. Functions

Configuration Storage

- You can save the configuration after entering all camera information required and previewing the video.
- Once you save the configuration, you can easily start its corresponding video from the IP App. main page.
- All camera settings are saved. When changing the camera settings, please save the configuration again.

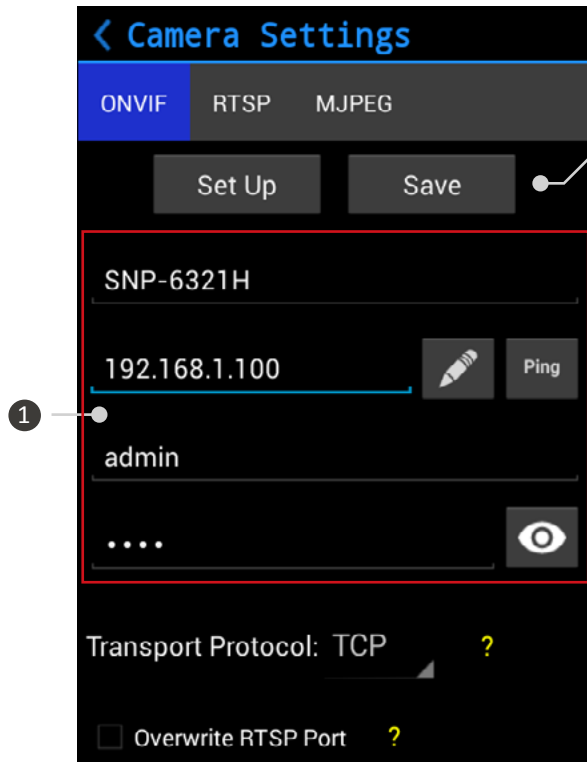

- ① Stored Information
 - All setting information to set a camera such as Name, IP Address, ID and Password is saved.
 - Configuration saving is available only when any camera has been connected successfully.
 - The camera model name is not displayed in RTSP, MJPEG configuration.
- ② Save
 - Tap the Save button in the Camera Setting page to save the configuration to the IP App. main page.

IP App. Functions

Camera Configuration Context Menu

- Press and hold a saved configuration or Set key. A menu will be shown as the following picture.
- Some functions are not available for RTSP, MJPEG configurations, which are not ONVIF.

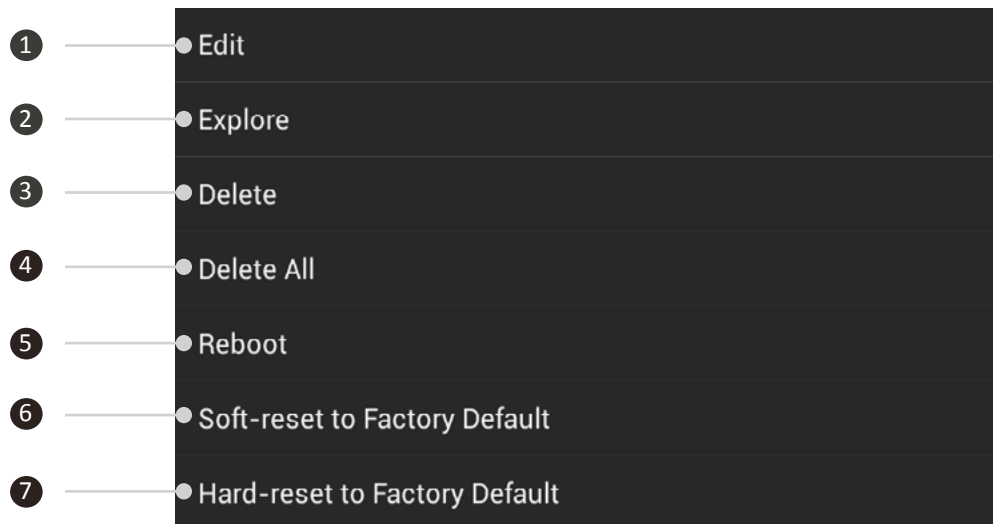

No.	Name	Description
①	Edit	Open the IP Camera Settings page to modify the configuration.
②	Explore	Check extensive ONVIF properties of the camera.
③	Delete	Delete the selected configuration.
④	Delete All	Delete all saved configurations.
⑤	Reboot	Reboot the selected camera.
⑥	Soft-reset to Factory Default	Reset the camera settings except for the network setting to the factory default.
⑦	Hard-reset to Factory Default	Reset the camera settings to the factory default.

- If the camera connection of the saved configuration is unstable or disconnected, Edit, Delete and Delete All will be enabled only.

IP App. Functions

Monitor IP Settings

- Tap the Monitor Settings icon in the main page of the IP App. to open the Monitor Network Settings page.
- Tap Advanced Configure at the bottom of the screen to display the following image.

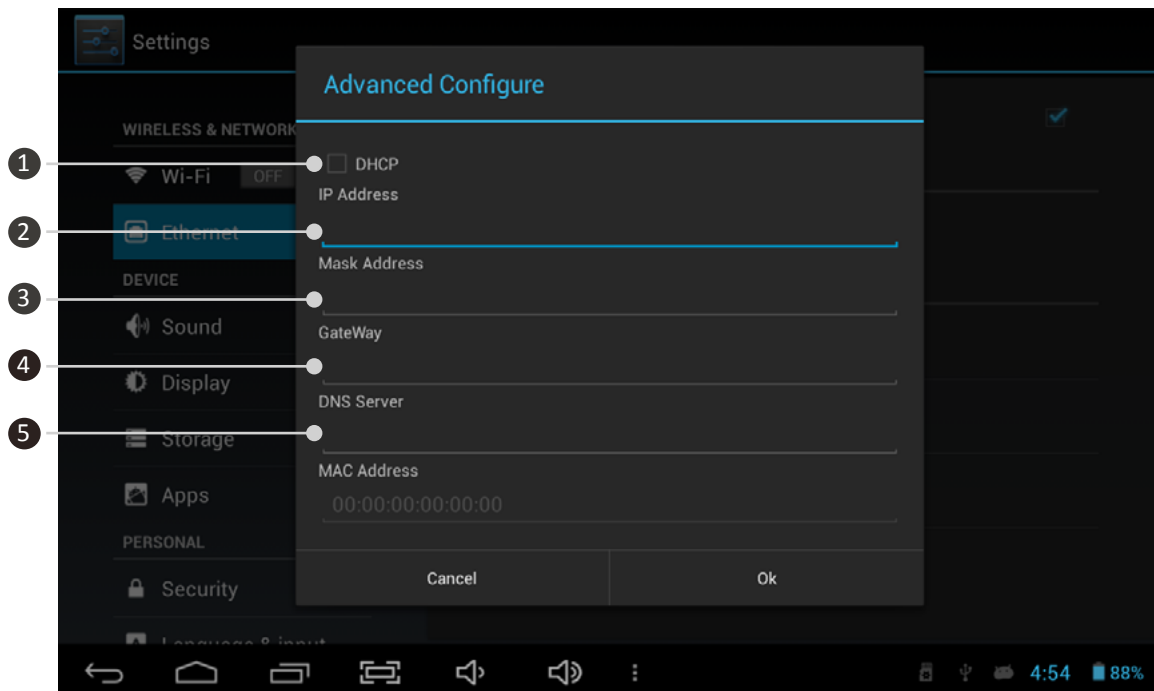

No.	Name	Description
①	DHCP Setting	If you check DHCP, a DHCP server can assign IP to this test monitor. It does not mean that the test monitor becomes a DHCP server.
②	IP Address	Enter the IP address. This test monitor normally uses 169.254.1.2 or 192.168.0.10. To connect an IP camera, please enter the same range of the camera IP address. For more information, please check page 43.
③	Mask Address	Enter the Subnet Mask address. For this test monitor, 255.255.0.0 is the most recommended.
④	Gateway	Enter the Gateway address. It has to be modified, depending on the entered IP address.
⑤	DNS Server	It is not related to any monitor's functions.

IP App. Functions

IP Address Selection

- IP address classes shall match each other.
- The range of the numbers available for IP address is from 0 to 255. All IP address classes can be identified with the bit of the first number. With other classes, it cannot communicate with each other.
 - Class A: 1.0.0.1 ~ 127.255.255.254
 - Class B: 128.0.0.1 ~ 191.255.255.254
 - Class C: 192.0.0.1 ~ 223.255.255.254
 - Class D: 224.0.0.0 ~ 239.255.255.255
 - Class E: 240.0.0.0 ~ 254.255.255.254

Class	No. of available addresses	Subnet Mask	Private IP
Class A	16,777,216	255.0.0.0	10.0.0.0 ~ 10.255.255.255
Class B	1,048,576	255.255.0.0	172.16.0.0 ~ 172.32.255.255
Class C	65,536	255.255.255.0	192.168.0.0 ~ 192.168.255.255
Class D	Not available. Normally for multitasking.		
Class E	Not available. Normally for testing.		

- Private IP address in the above table is available for communication on the same network, but cannot pass through the router. It is used for LAN only.
- Specific IP addresses such as Class D/E are not available for use. These IP addresses are normally used for specific purposes such as multicasting or broadcasting. If you use this kind of IP addresses in general, it may cause some problem in network.
- Network specifications depend on each camera manufacturer. Class C is used in common and for large/medium-sized network, Class B is generally used.
- If you connect an IP camera with an IP address except for private IP addresses, it may be disclosed on the Internet and be in danger of being hacked.

Link-local Address

- All devices supporting zero-configuration have one or more link-local addresses.
- The range of the link-local address is from 169.254.0.0 to 169.254.255.254
- All network cameras supporting zero-configuration can be discovered and connected with this test monitor, but their regular private IPs (e.g. 192.168.x.x) take precedence.

IP App. Functions

Ping Test

- You can check the connection status of the camera by Ping test.
- For Ping test, the camera's IP address is used only.

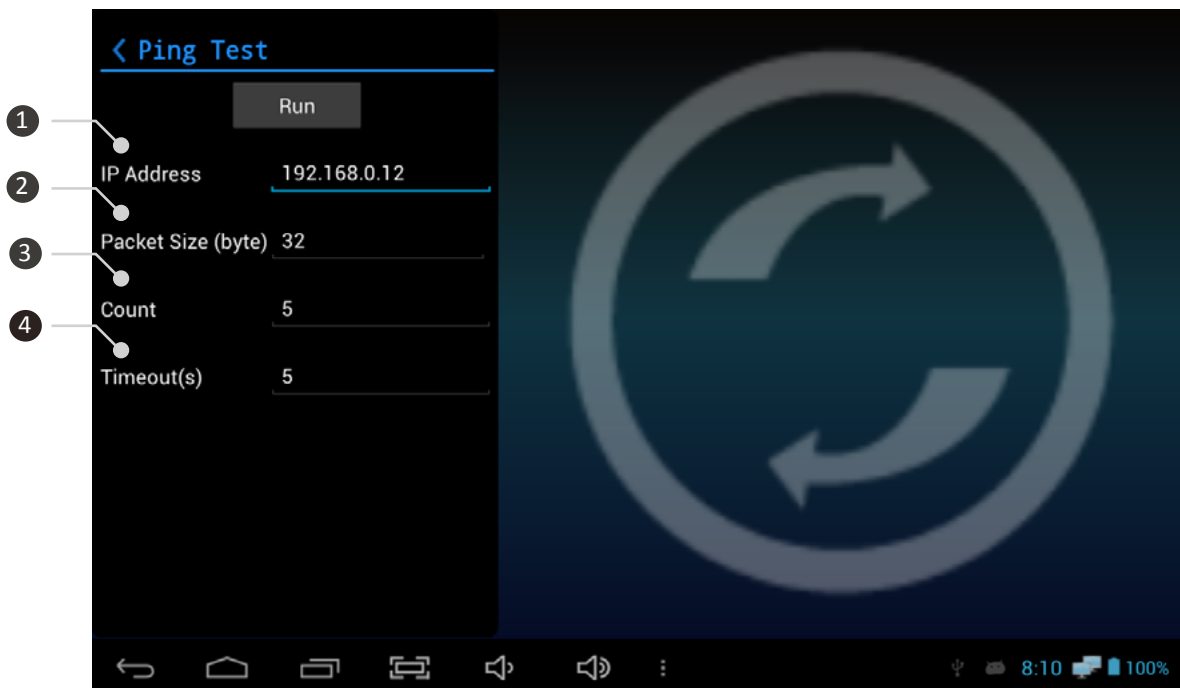

No.	Name	Description
①	IP Address	Enter the camera IP address for the Ping test.
②	Packet Size (byte)	Set the packet size of the Ping to transmit. It can transmit up to 1024 byte.
③	Count	Set the number of packets to transmit.
④	Timeout (s)	Set a specific time for the packet return. If the packet comes back after the specified time, a timeout error is generated.

Viewer App. Functions

Main Page

- Viewer App. means an App. for SDI, HDMI, AHD, CVI, TVI, CVBS.
- Wi-Fi should be off for SDI input. It may generate some video noise in a long-distance transmission.
- SDI products should be connected to SDI Input BNC port and HD analog/CVBS products shall be connected to Video Input BNC port for the relevant video signal input.
- When entering HDMI audio for a long time, the sync may have some errors.

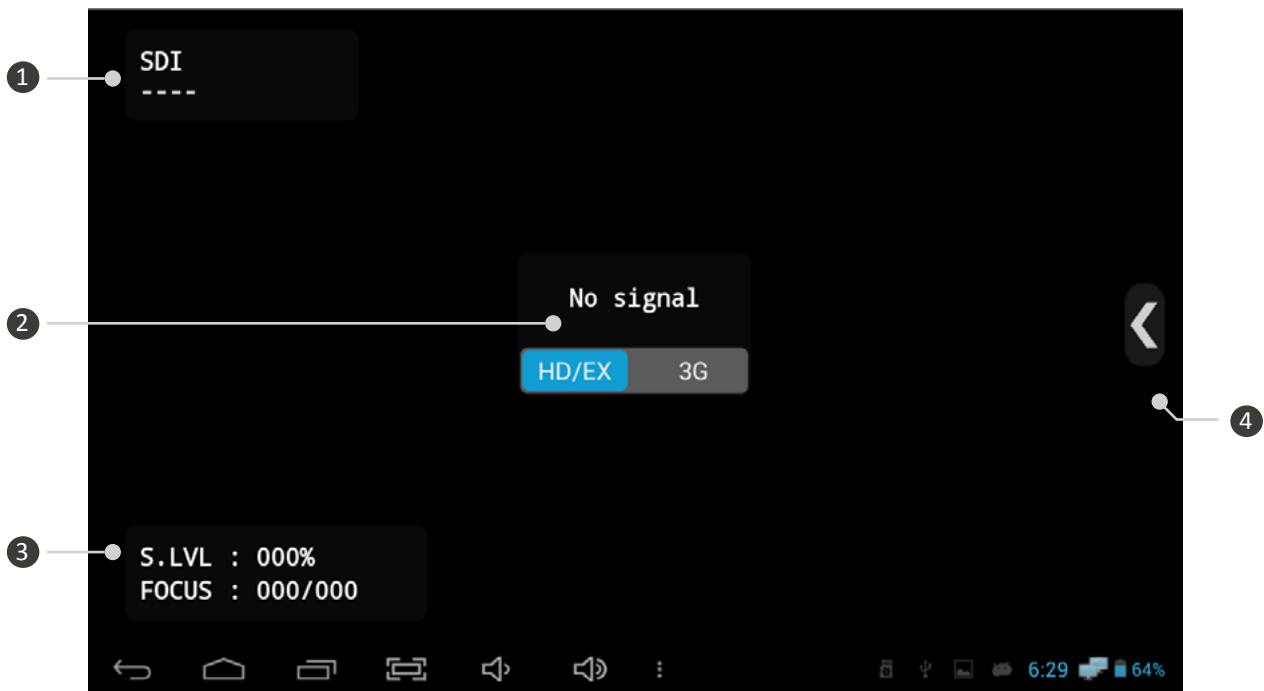

No.	Name	Description
①	Video Input Status	When no video is entered, it displays "----" as shown in the above picture. The resolution of the input video is shown just after entering video and the window will be closed in 10 seconds.
②	Input Mode	When no video is entered, it displays "No Signal" on the screen. In SDI mode, HD/EX-SDI or 3G-SDI is selectable.
③	Level Meter/ Focus Meter	Level Meter function is for checking signal status more easily and accurately in numerical values. Signal size is proportional to the signal quality, so if the value is greater, it means the signal quality is better. Depending on signal size, the following letters and percentage will be displayed at the bottom left corner. SDI mode has S. Level meter and AHD/CVI/TVI/CVBS modes have A. Level and F. Level meters. 0 ~ 29%: NG 30~59%: Normal 60~100%: Good Focus Meter function is to adjust the camera focus more easily and accurately in numerical values. This function is shows the optimum and current focus status(depth) in real time. The focus depth is represented in numerical values between 255 and 0.
④	Video Menu	This menu includes PTZ/OSD/UTC, Record, Capture, Gallery(Playback), PoC functions and Settings, etc.

Viewer App. Functions

Supported Resolution

- When entering video, the signal format and resolution are displayed.
- Select 3G in the input mode for 3G-SDI video input.
- The Video Input Status window will be closed in 10 seconds after video is entered.

SDI
1920X1080p30

① HD-SDI Supported Resolution

- 720p 25/30/50/60 Hz Input
- 1080i 50/60 Hz Input
- 1080p 24/25/30 Hz Input

SDI [EX]
1920X1080p30

② EX-SDI Supported Resolution

- 720p 25/30/50/60 Hz Input
- 1080i 50/60 Hz Input
- 1080p 24/25/30 Hz Input

3G-SDI
1920X1080p60

③ 3G-SDI Supported Resolution

- 1080p 50/60 Hz Input

AHD
1920X1080p30

④ AHD/TVI/CVI Supported Resolution

- 720p 25/30/50/60 Hz Input
- 1080p 25/30 Hz Input

CVBS
NTSC

⑤ CVBS Supported Resolution

- NTSC/PAL Input

HDMI
1920X1080p60

⑥ HDMI Supported Resolution

- Up to 1080p 60HZ Input
- Specific resolutions are not supported

Viewer App. Functions

Signal Level Meter function

1. SDI Level Meter

- SDI Level Meter represents the current SDI signal status (signal size) in percentage.
- 100% means the most optimum signal status (the biggest signal size) and the lowest value is 0%.

S. LVL : 15% NG
FOCUS : 100/100

- ① No Good
- NG displayed in 0~29%
 - Severe signal attenuation

S. LVL : 45% Normal
FOCUS : 100/100

- ② Normal
- Normal displayed in 30~59%
 - Normal-state signal

S. LVL : 90% Good
FOCUS : 100/100

- ③ Good
- Good displayed in 60~100%
 - Signal in good condition

2. Analog Level Meter

- Analog Level Meter represents the current Analog signal status (signal size and brightness) in percentage.
- The Level Meter can measure signal attenuation rate and adjust the level of the UTP receivers.

A. LVL : 100%
F. LVL : 100%
FOCUS : 100/100

- ① A. Level
- A. Level represents the signal brightness size (Sync.) and the standard value is 100%. Lower value means more signal loss, that is, decreased brightness and increased noise.
- ② F. Level
- F. Level represents the video color size (Burst) and the standard value is 100%. Lower value means lower resolution and worse color reproduction.

! How to adjust the level value of UTP receivers

- It is possible to adjust the level value accurately in case of the UTP receivers
- Set both A. Level and F. Level close to 100% and adjust it by checking the actual video.

Viewer App. Functions

Focus Meter function

- Focus Meter represents the optimum and current focus status(depth) in numerical values
- The focus depth is represented in numerical values between 255 and 0. Adjust the optimum and current focus depth to be matched.
- This value depends on camera or lens types.



A. LVL : 100%
F. LVL : 100%
FOCUS : 098 / 225

Current Value Optimum Value



A. LVL : 100%
F. LVL : 100%
FOCUS : 225 / 225

CRC Error Count function

- CRC Error Count measures the number of CRC errors in HD/EX/3G-SDI mode.
- When HD/3G-SDI is entered, CCRC and YCRC values will be displayed. For EX-SDI input, XCRC value will be displayed.

CCRC : 000
YCRC : 000
TIME : 00 : 00 : 00

HD/3G-SDI Mode

XCRC : 000
TIME : 00 : 00 : 00

EX-SDI Mode

- ① To activate this function, press the Set button once after connecting the camera
- ② To initialize the values, press the Set button for two seconds during CRC measurement.
- ③ To terminate this function, press the Back button.

Viewer App. Functions

Video Menu Bar

- Available menu in this bar depends on video signal mode.
- Press the Menu, Mode button or Menu icon , the Menu bar will be popped up as shown as follows.

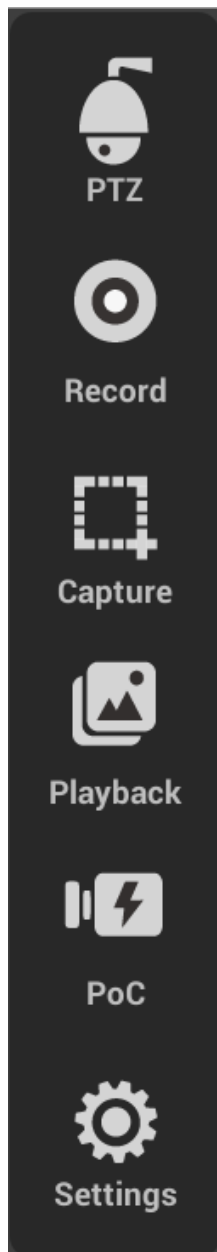

- ① PTZ
 - PTZ Capacity or OSD settings are available through RS-485.
 - It is possible to receive or analyze data by using RS-485.
 - Deactivated in HDMI mode.
- ② Record
 - It is available to record the input video.
 - Other Capacity is not available during recording.
- ③ Capture
 - It is available to capture the input video.
 - The recorded or captured images are saved in Gallery.
- ④ Playback (Gallery)
 - Recorded or captured images are stored here.
- ⑤ Power over Coaxial(Optional)
 - Supply power to camera over a coaxial cable.
 - This function is available for PoC camera only.
 - Other Capacity is not available during PoC operation.
 - Deactivated in AHD, TVI, CVI, CVBS, HDMI modes.
- ⑥ Settings
 - Set where to save the recorded or captured images.
 - Turn on/off the Level and Focus Meter functions

Viewer App. Functions

PTZ

- To implement PTZ function, the Mode, Protocol, Address and Baudrate must be set. For RS-485, match the polarity for cable connection.
- UTC function is activated in HD Analog and CVBS modes and by this function, camera control via coaxial cable is available.

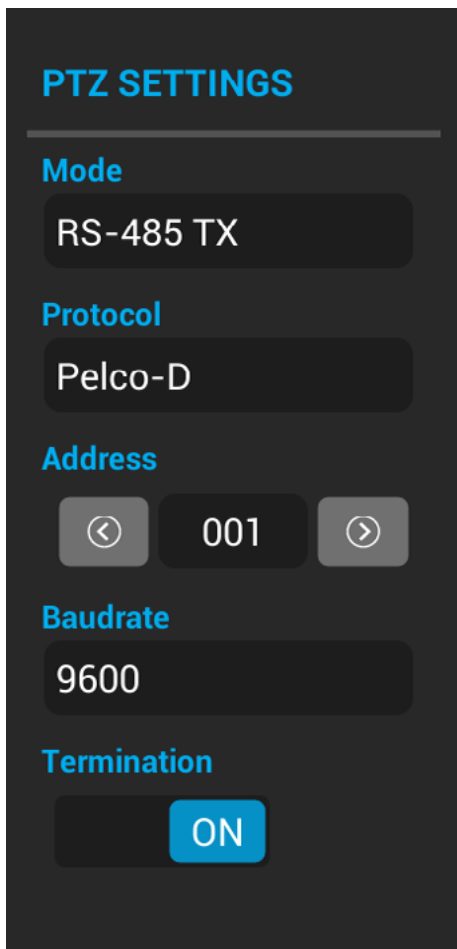

① Mode Settings

- This part includes RS-485 Tx, RS-485 Rx, Analyze and UTC.
- RS-485 Tx mode is for PTZ and OSD control.
- RS-485 Rx receives PTZ control Hex value.
- Analyze mode analyzes protocols received through RS-485 port and confirms the command and Hex values at the same time.
- UTC mode is to control a camera over coaxial cable.

② Protocol Settings

- Set the protocol and device to control in the same way.

③ Address Settings

- Set the address and device to control in the same way.
- Address represents the camera ID.

④ Baudrate Settings

- The available baudrate is 2400, 4800, 9600, 19200

⑤ Termination Resistance

- 75Ω termination resistance is available.
- Termination resistance is used to avoid of reflection effects which is generated by the impedance of transmitters.

! Cautions for RS-485 Settings

- Make sure to check the polarity in RS-485 connection
- Protocol and Address settings are not required for use of RS 485 Rx.
- Address settings are not required to use Analyze function.
- Address and Baudrate settings are not required for UTC

Viewer App. Functions

RS-485 Tx

- The current settings are displayed on the top of the screen.
- Control the directions by arrow keys, referring to the instructions at the bottom of the screen.

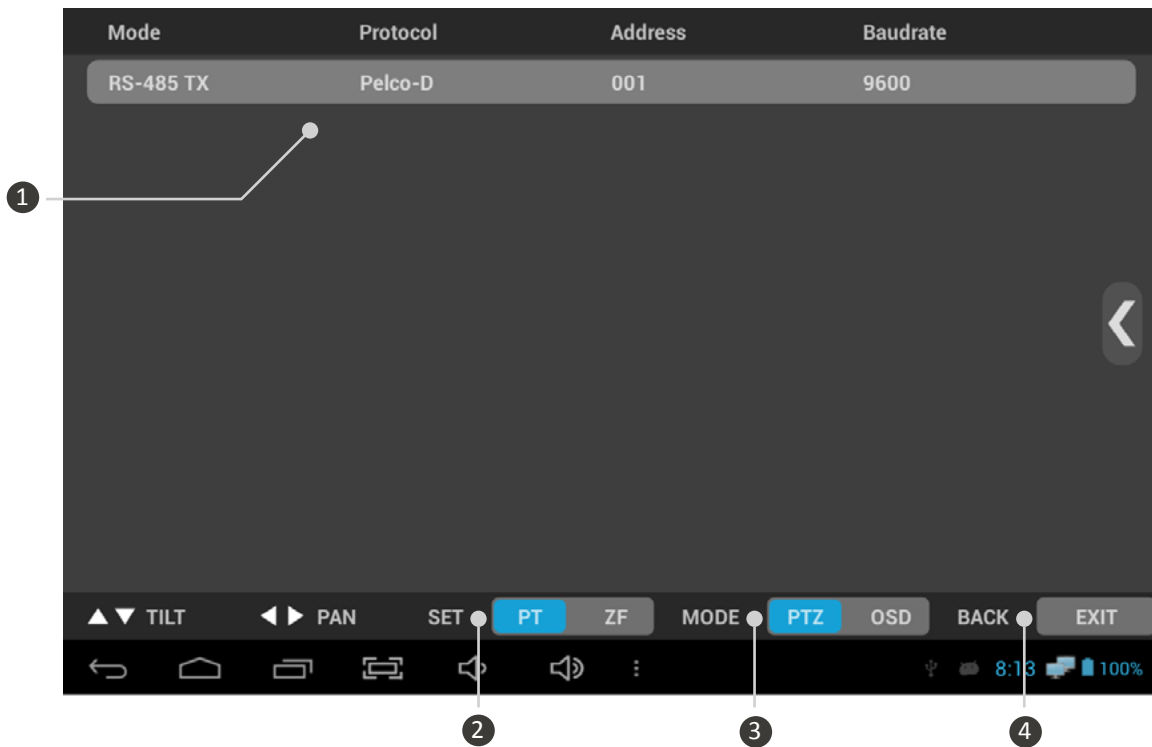

No.	Name	Description
①	Setting Status	All setting values such as mode, protocol, address, baudrate are displayed.
②	PTZ Mode	In PTZ mode, you can select and change Pan/Tilt and Zoom/Focus by touch or set key. In OSD mode, the function will be implemented according to the selection keys.
③	Operating Mode	You can select and change PTZ or OSD mode. The set functions depend on the operating mode.
④	Back button	This button is to terminate RS-485 in PTZ mode and terminate OSD menu in OSD mode.

! Cautions for setting protocols

- Protocol commands depend on camera manufacturer.
- Appropriate protocol for camera shall be used.
- Back button may not work in OSD mode, depending on protocol.

Viewer App. Functions

RS-485 Rx

- The current settings are displayed on the top of the screen.
- Data transmitted through RS-485 cable is displayed in HEX value on the screen.
- When the data is more than 264 Byte, the previous data will be deleted.



Analyze function

- RS-485 commands received from CCTV controller or external devices are displayed.

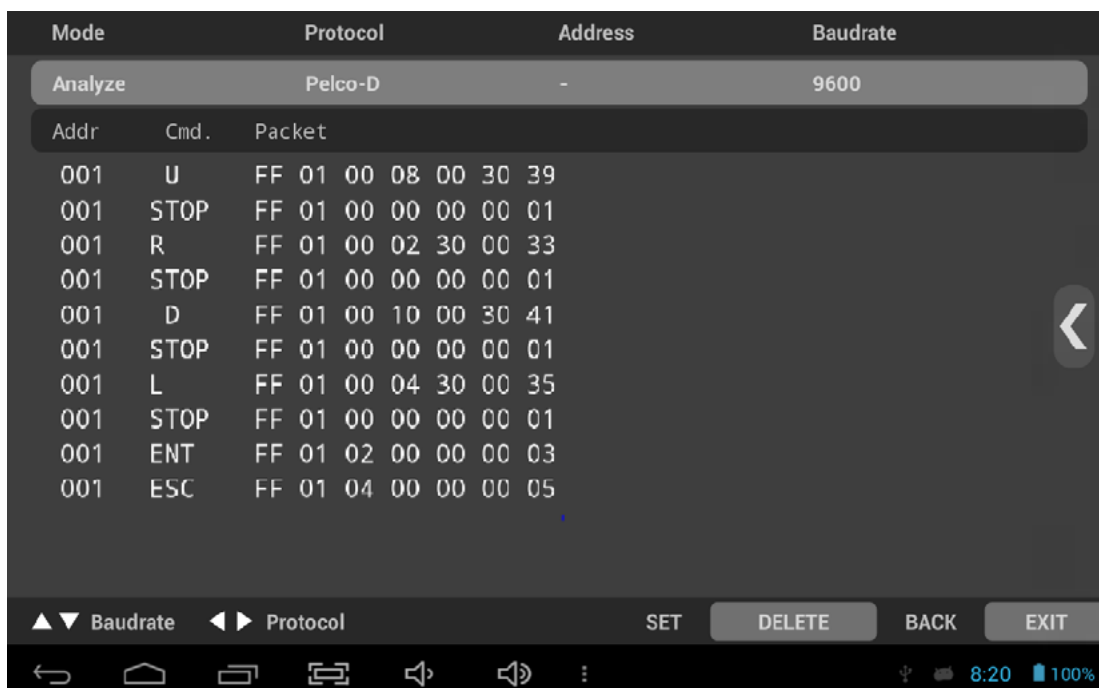

Viewer App. Functions

UTC

- UTC is available in HD Analog and CVBS modes.
- Camera PTZ or OSD settings are available over coaxial cable without any separate data lines.

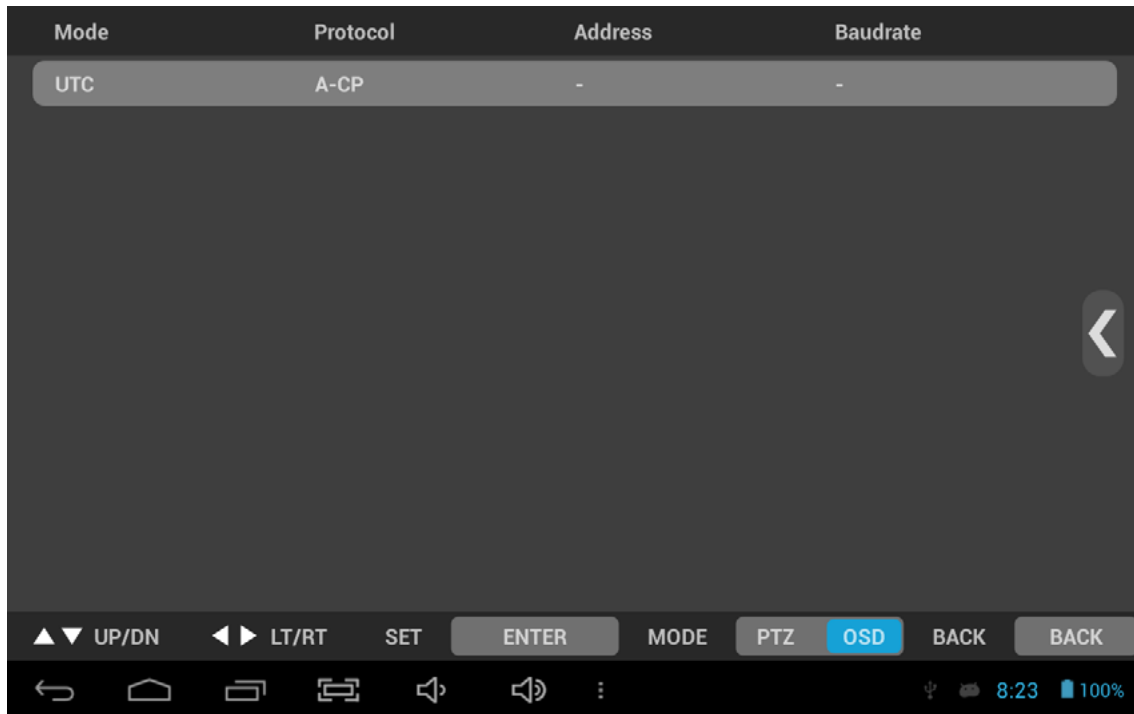

No.	Name	Protocol	Supported Items
①	CVBS Mode	Pelco- C	Hanwha (Samsung) Techwin (Winner5), Pelco, D-Max (PIXIM)
②	AHD Mode	A-CP	Cameras supporting AHD UTC
③	TVI Mode	TVI UTC	Cameras supporting TVI UTC
④	CVI Mode	CVI UTC	Cameras supporting CVI UTC

! Cautions for using UTC function

- UTC function for HD Analog may not work properly in a long distance
- Video may be flickering during UTP operation.
- UTC function for 3MP or higher-resolution cameras may not work properly, depending on the camera's brand.

Viewer App. Functions

Video Recording

- It is not recommended to record for a long time without any memory card.
- Mount Micro SD card if the internal storage capacity is not sufficient.
- You can set the storage location in Settings after mounting Micro SD Card.
- When recording video, it is saved in MP4 format.

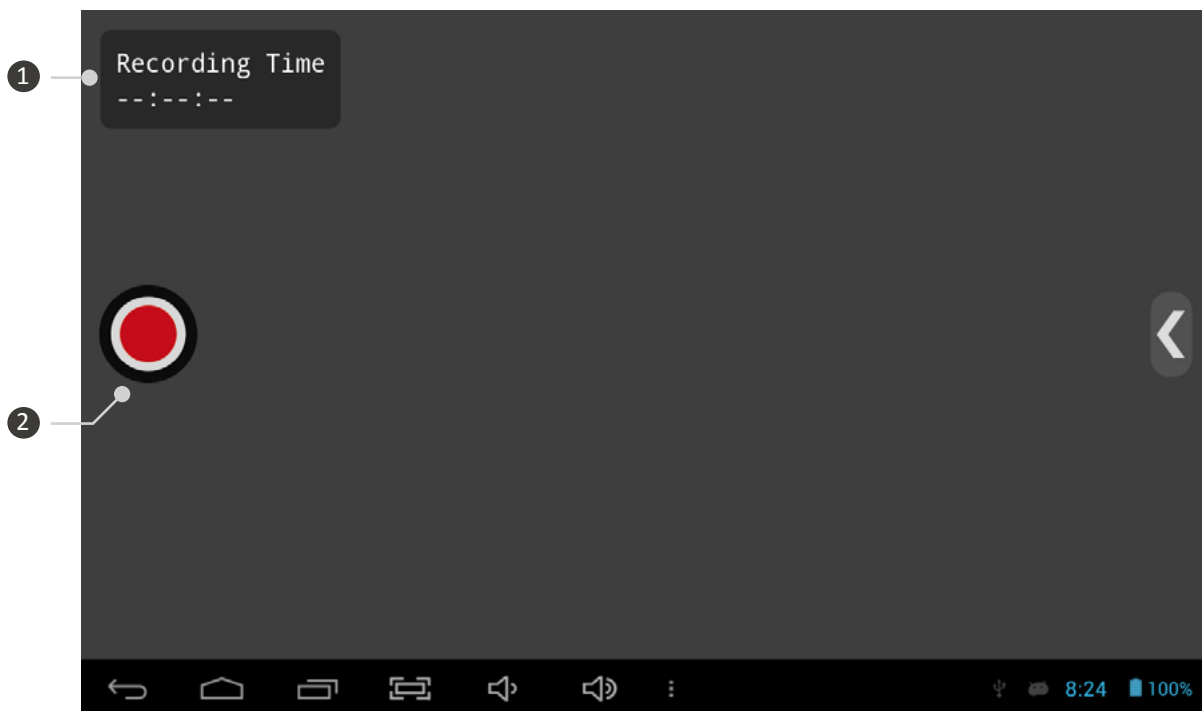

No.	Name	Description
①	Recording Status	Check the recording time and status. Once the recording is finished, the recorded video will be stored in Gallery.
②	Recording Button	Start/End recording by pressing the recording button.

! Cautions for recording

- When the internal capacity is full, recording is not available anymore and will be terminated. The recorded images will be saved automatically.
- The quality of the recorded video depends on the video transmission quality.
- For AHD/TVI/CVI, up to 2MP can be recorded.

Viewer App. Functions

Video Capturing

- It is available to capture and save images in JPG format.
- Mount Micro SD card if the internal storage capacity is not sufficient.
- You can set the storage location in Settings after mounting Micro SD Card.



How to use Gallery

- The recorded or captured images are saved in Gallery.
- The routes for video generated in the IP App. and Viewer App. are displayed differently.
- If you unmount the Micro SD card during using Gallery App., some problem may occur in the stored files.

Viewer App. Functions

PoC function

- Supply power to the camera over coaxial cable.
- PoC function is activated in SDI mode and available for PoC cameras only.
- PoC function is optional.

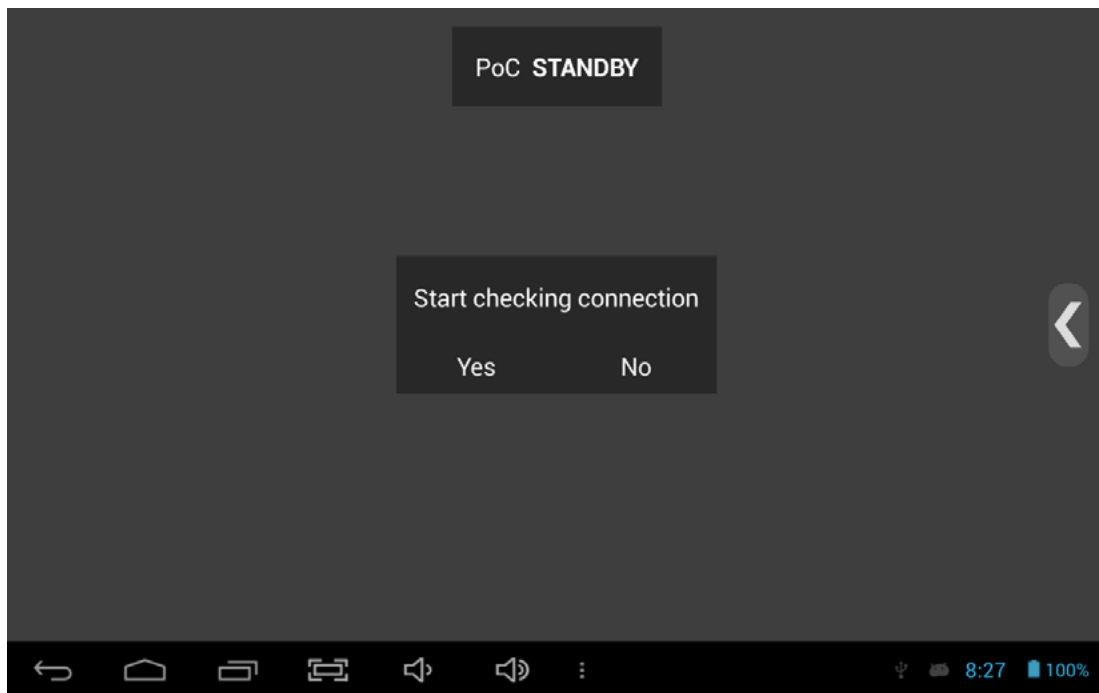

No.	Name	Description
①	PoC Standby	The step before operating PoC. One you select “Yes”, it starts trying to connect PoC.
②	PoC Connection Checking	If the connected camera is PoC camera after checking, it moves to the next step.
③	PoC Supply Standby	PoC camera is connected. To supply power to the camera, press “Yes”. Then, it moves to the next step.
④	PoC Power Supply	Supply power to the camera for its operation.
⑤	PoC Operation	PoC is being supplied to the camera currently.
⑥	PoC Cable Disconnected	This is displayed when removing the cable during PoC operation or when operating PoC function without connecting a cable.

Viewer App. Functions

User Settings

- This menu is to set the storage location, or turn on/off the Level/Focus meter functions.

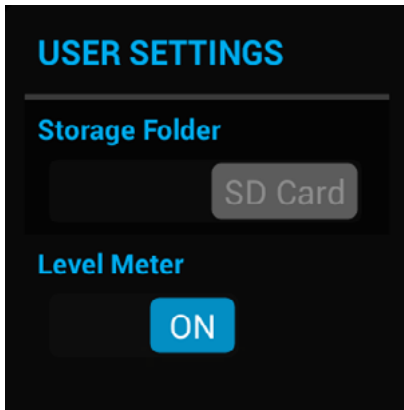

- ① Storage Folder
 - Set where to save the recorded or captured images.
 - Activated only when Micro SD Card is mounted.
- ② Level/Focus Meter
 - Turn on/off the Level/Focus meter functions.
 - The level meter will not be displayed in HDMI mode.

Appendix

App. Update

- Use update App. to update Launcher, Viewer and IP App.
- Available during WI-FI only.
- Enter My Apps to update App.

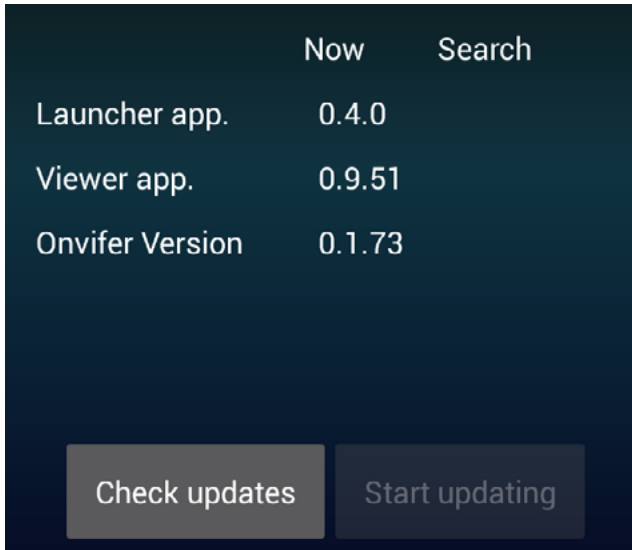

① Check updates

- Check the currently installed version during WI-FI.
- Not activated when the currently installed App. is the newest version.

② Start updating

- Activated when the currently installed App. is not the newest version.
- Tap this button to update each App. The update speed depends on WI-FI.

! When the update is not working properly

- Remove the App. and retry it if errors occur during the update.
- Retry the App. if it is stopped during the update.
- Check if there is sufficient storage space inside when parsing error message is displayed.

USB LAN Card

- Please use the USB LAN card that is provided in the package. Other USB LAN cards may not work with this test monitor.
- Turn on Wi-Fi in Settings after mounting the USB LAN card onto the test monitor to use Wi-Fi.



Appendix

Specifications

Model		IP Test Monitor	
LCD	Display Resolution		1280 X 3 (RGB) X 800
	Size		7.0 inch (Diagonal)
	Pixel Pitch		0.117(H) X 0.117 (V) mm
	Brightness		400 cd/m ²
	Viewing Angle		89deg (Horizontal) / 89deg (Vertical) Total: 178deg (IPS Panel)
	Response Time		11ms
Video	INPUT	HD-SDI	1.485Gbps
		3G-SDI	2.970Gbps
		EX-SDI	270Mbps
		HDMI	Up to 1080p 60Hz
		AHD	1280x720p 25, 30Hz
			1920x1080p 25, 30Hz
		CVI	2560x1440p 15, 25, 30Hz
			1280x720p 25, 30, 50, 60Hz
		TVI	1920x1080p 25, 30Hz
	2048x1536p 18.75Hz		
	CVBS	2560x1440p 25, 30Hz	
1280x720p 25, 30, 50, 60Hz			
LAN	1920x1080p 25, 30Hz		
	2048x1536p 18.75Hz		
OUTPUT	2560x1440p 25, 30Hz		
	2592x1944p 12.5, 20Hz		
Measurement	Analog	HDMI	NTSC, PAL
		LAN	10 / 100Mbps - IP Cam & PoE (Power of Ethernet) Support
		HDMI	1080p 60Hz
		A.LEVEL	10 ~ 118 %
		F.LEVEL	20~120 %
		ERROR RATE	± 2%
		FOCUS LEVEL	0 ~ 255

Appendix

Specifications

Model		IP Test Monitor	
Measurement	SDI	SDI LEVEL	0 ~ 100 %
		ERROR RATE	± 2%
		FOCUS LEVEL	0 ~ 255
	IP	FOCUS LEVEL	0 ~ 255
Power	INPUT		DC 12.6V (Exclusive Adapter)
	OUTPUT		DC JACK 12V / 500mA
			USB 5V
Connection Port	HDMI Input / Output		HDMI C Type F
	HD-SDI Input		BNC-F
	LAN Input		RJ-45
	Analog Input		BNC-F
	USB Input		USB 2.0
	Micro SD Input		Standard Type
	RS-485 Input		2P Terminal Block
Battery		Li-Polymer 11.1V, 5,680mAh	
Language		Korean, English, Japanese, Italian, German	
Operating Temperature		0°C ~ + 50°C	
Operating Humidity		0% ~ 80%	
Storage Temperature		-10°C ~ + 50°C	
Material		PCABS Flame Retarding Material	
Weight		1014g	
Dimensions		246(W) X 160(H) X 49.9(D)mm	

Appendix

FAQ

Symptom		Checking Method
No video display	Viewer	Reboot this test monitor.
		Check the connected cable status. Video may not be displayed, depending on the damage or length of the cable.
		Check the connected camera status.
		Check the termination resistor status. The signal size depends on the termination resistor settings.
		Check the battery. There may be some problems with power.
		Check the camera resolution. The supported resolution depends on video signal type.
	IP	Check the connected LAN cable status. There may be some problems with the video, depending on the damage of the cable or interference.
		Check the cable type. There may be some problems with the product operation, depending on cable types.
		Check the WI-FI status if connected wirelessly. The video may not be displayed if the strength of the signal is weak or the signal dies frequently.
		Check the networking settings. If setting value is different such as the camera IP address, subnet mask and gate way, the video may not be displayed.
		Check the network settings of this product. The IP range of the IP camera and this product should be same to check the video.
		Check if 'Use Ethernet' is marked in Monitor Settings. It must be marked all the time for using IP App.
		Check the status of connected network devices such as routers, Hubs, etc. There may be some problems with the network settings.
		Check if the camera supports ONVIF. This product supports ONVIF protocol cameras.
Check the supported camera codecs. This product supports H.264, JPEG codec.		
Check the camera network mode. This product does not support DHCP server and is available for connection in manual IP.		

Appendix

FAQ

Symptom		Checking Method
Video is NOT displayed	IP	When a camera uses any separate RTSP port, it may not be connected. For camera settings, please overwrite and change the RTSP port. - The default RTSP port is 554. It may depend on each camera brand.
		If you initialize a camera after saving its configuration, it may not be able to connect the camera via the saved configuration. It may be caused due to the difference of the initialization methods per camera brands. In this case, you should search the camera and follow the other steps for its connection again.
PTZ and/or OSD are Not available	RS-485	Check the connected cable status. It is not available in different polarity.
	UTC	Check camera UTC protocols. The protocols depend on each camera manufacturer.
		Check the length of the connected cable. UTC may not work, depending on the length of the cable.
Micro SD and/or USB are NOT available		Check the termination resistor status. There may be some problems with UTC due to the termination resistor settings which generate change of the signal size.
		Check Micro SD/USB status. There may be some problems with the operation if the product is bent or cracked.
		Check the manufacturers of Micro SD/USB. If not certified memory cards are used, there may be some problems with the product operation.
		Unmount and mount Micro SD/USB again. Recognition errors may be generated intermittently.
		Check the USB supported version. This product supports USB 2.0
The test monitor is paused		Reboot this product. There may be some problems with the program.
		Press and hold the power button for about 7 seconds to shut down this test monitor forcibly when the touch pad or D-pad does not work properly. After then, please turn it on again for use.
		Press and hold the power button for about 7 seconds to shut down this test monitor when the monitor is paused during use . After then, please turn it on again for use.

Appendix

Extra Features

- Security (Lock) mode

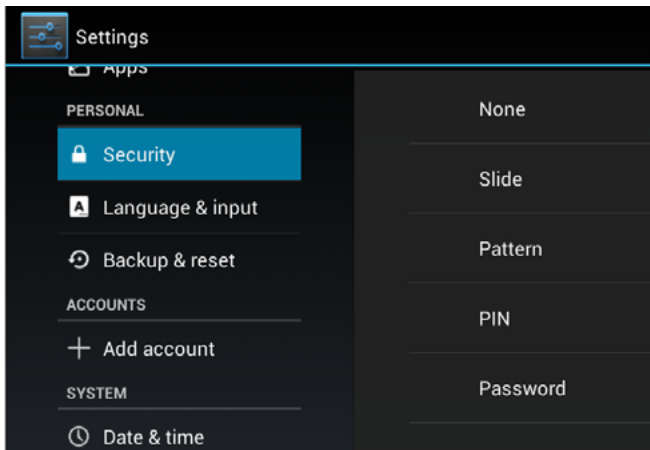

① Lock mode setting

- Lock for prevention of robbery
- Initialization is not available if you do not remember password or pattern once you lock it.

- Miracast mode

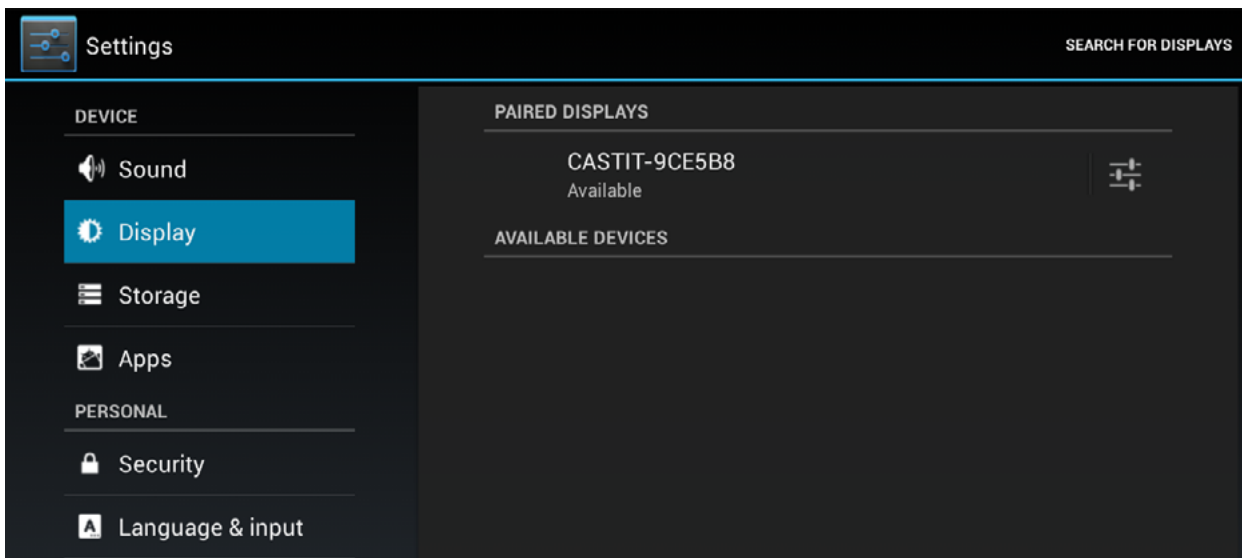

① Miracast

- Search products currently available for Miracast by entering Display < Wireless Display < Search Display
- Miracast is technology that share video and audio by wireless connection. It is available during Wi-Fi.

Appendix

Warranty Certificate

Model No.		
Serial No.		
Distributor		
Date you purchased		
Place you purchased		
Warranty Period		Two (2) years from the date of purchase
Purchaser	Name	
	Address	

This product has passed thorough quality control and test, and if this gets broken during normal use, we provide the two-year warranty service.

- Contact your distributor after checking out any defect in the products.
- The warranty covers only those defects that arise as a result of normal use of the product and repair service free of any charge will be provided according to the warranty certificate.
- We charge you with the fee for parts and services provided despite of free warranty service period in case of:
 - Breakage or trouble made by natural disaster (lighting, fire, flood, tsunami, etc.)
 - Breakage or trouble made by breaking the product guide or manual.
 - Breakage or trouble made by wrong power voltage or frequency.
 - When you want to reassemble for full system or replace parts within the warranty service period.
 - When unauthorized person modified or made damage on the product trying to repair it.