



## XC DUO

1.8 kW | Stove-Heater Combination

Power:	900-1800 W / 3,000-6,100 BTU
Operating Voltage:	12 V
Fuel Consumption:	0,09-0,19 l/h / 3.0-6.4 oz/h
Electricity Consumption:	0,55-0,85 A
Colors:	Stainless steel, black
Recommended For:	Camper vans
Type Approved:	ECE-R122, ECE-R10



XC Duo multipurpose unit is a forced air diesel stove and a heater powerful enough to warm up small to mid-size camper vans even in icy cold temperatures. Left side of the ceramic top is for boiling in higher temperatures, right side is for simmering at a slightly lower temperature. With the blower lid lowered, the unit operates as a heater producing dry heat, which keeps the windows condensation-free and the furnishing fresh. As the diesel fuel can be drawn directly from the fuel tank of the vehicle, there is no need to remember to fill separate tanks. In addition to fossil-based diesel, the Wallas Greenboost burner burns renewable diesel (HVO) cleanly and energy-efficiently resulting in very low NOx and CO2 values.



## PI THERMO

THERMO | Control Panel

- Start the unit simply by a press of a button
- Adjust cooking heat steplessly in **Manual Mode** by turning the heat knob.
- Use **PI Thermo Mode** to set a desired temperature for indoor air heating.



Choose from two lid colors:

Stainless steel  
Black

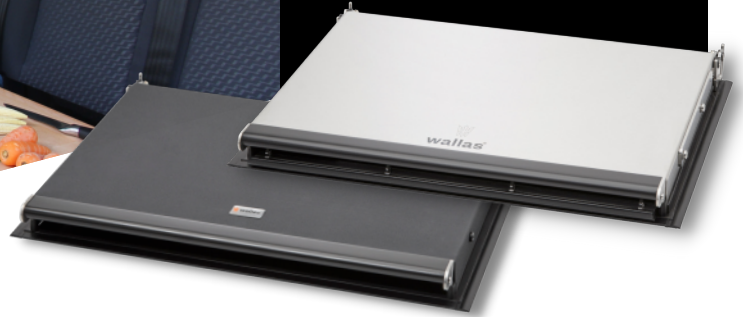

Combustion air is taken from outside of the vehicle, which means the unit can be run safely over night with windows and doors closed.

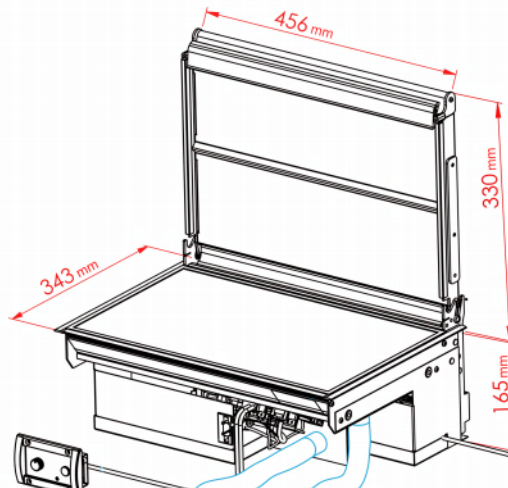

## INSTALLATION

Easy installation can be done independently or by a Wallas professional.

Fuel pump dispenses fuel and the electronics control the combustion air automatically to keep the flame of the burner clean.

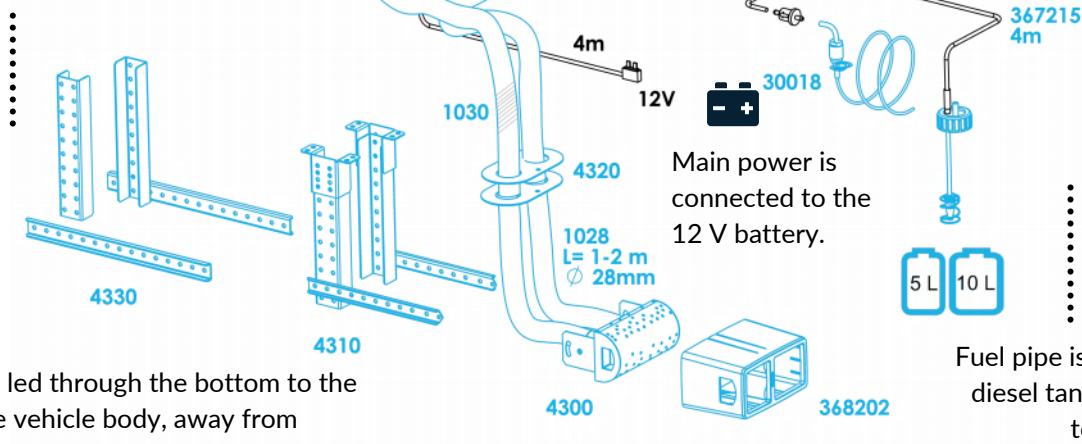

Exhaust is led through the bottom to the side of the vehicle body, away from vegetation below the camper van.

## FEATURES

- Laminar combustion is a safe enclosed burning process with no exposed flame.
- Sealed combustion does not leak any odors into the camper van and dries the indoor air.
- Stylish flush-mounted cooktop is easy to keep clean.
- Heating power is sufficient to warm up small to mid-size camper vans even in icy cold weather.
- Parking in public garages and entering tunnels is allowed.
- Multipurpose unit saves space and weight.
- Efficient and economical unit is excellent for off-grid environments.



Accessories in black come with the standard package. Accessories in blue are additional/optional. All rights reserved. Wallas-Marin reserves the right to change or improve its products and to make changes in the content of this catalogue without obligation to notify any person or organization of such changes or improvements. Go to [www.wallas.com](http://www.wallas.com) for current updates and supplemental information concerning this product.