

# HOT WATER DISPENSER

MARK II

即熱過濾飲水機

WD3625W



W·A·S·H

## USER MANUAL 使用說明

感謝您購買本公司產品。  
為安全正確地使用本產品，使用前請務必詳細閱讀並理解本使用說明，  
並妥善保存本使用說明以便日後參考。

Thank you for purchasing our product.  
Before using the product, please read this user manual carefully and keep it for  
future reference.

網上保用登記  
Warranty Registration



# 目錄

(一) 產品簡介	2
(二) 產品規格	2
(三) 產品結構	3
(四) 操作介面	4
(五) 安裝指引	4 - 5
(六) 注意事項	6
(七) 清潔與保養	7
(八) 故障判斷	7
(九) 裝箱清單	8
(十) 產品保修說明	8

## (一) 產品簡介

感謝您購買我們的產品。本產品為即熱過濾飲水機，採用 2000W 高功率即時制熱技術，輕輕一按，三秒內即出不同溫度的水，簡單、方便、快捷，無論喝水還是製作各種飲品都沒有難度。更可配合濾水壺濾芯使用，加上30天濾芯更換提示，助您享用更美味的飲品！設有5種溫度選擇，包括常溫、45°C、65°C、80°C、95°C，無論日常飲用，泡茶，沖奶粉，煮杯麵都能一機包辦。配有3.6L特大儲水箱，可分拆方便清洗及換水，更設有安全鎖設計，避免意外。

- 純白簡潔纖巧外型，無論在家中還是辦公室使用，都可成為使用又美觀的電器
- 2000W 特快加熱，三秒內可出熱水
- 可選常溫、45°C、65°C、80°C、95°C 出水
- 3種出水模式 – 200毫升、300毫升、500毫升
- 3.6公升儲水箱
- 安全鎖功能：避免孩童單獨使用
- 配備30天濾芯更換提示

## (二) 產品規格

產品名稱	即熱過濾飲水機 第二代
產品型號	WD3625W
額定功率	2000W
額定電壓	220V~
適用水源*	純淨水/礦泉水/經自來水廠處理過的合格自來水，以及經檢測可安全飲用的私人供應水
進水水溫*	5~40°C
水箱容量*	3.6公升（最高水位）
過濾水容量	1.6公升
產品重量	2.2kg
產品尺寸	153Wx246Dx320Hmm

## (三) 產品結構

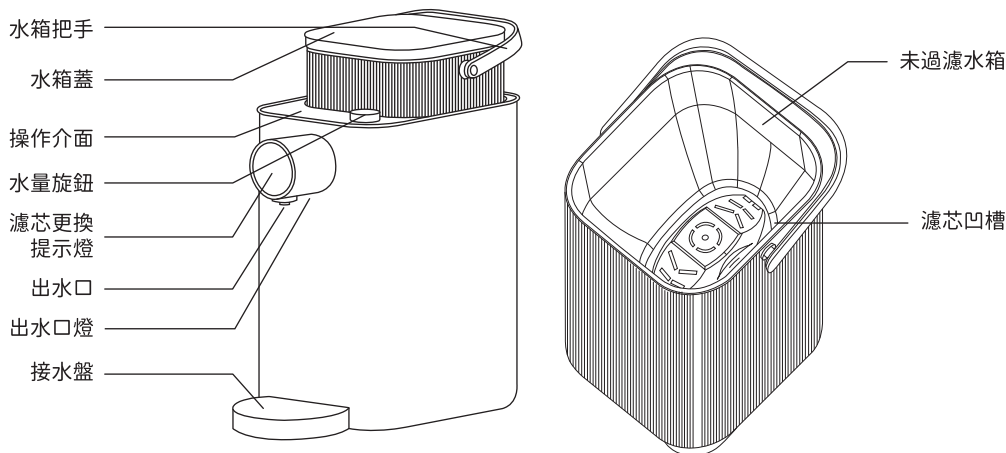

## (四) 操作介面

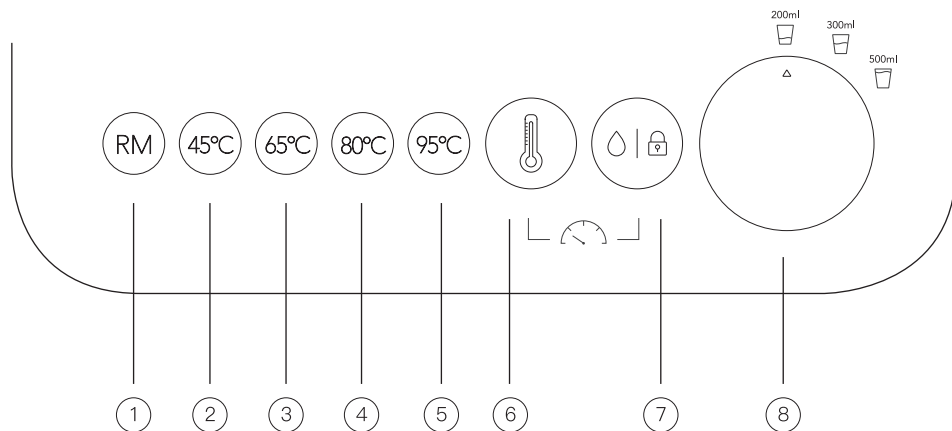

① 常溫提示燈

④ 80°C提示燈

⑦ 出水鍵/解鎖鍵

② 45°C提示燈

⑤ 95°C提示燈

⑧ 調節水量旋鈕

③ 65°C提示燈

⑥ 調節水溫鍵

⑥ + ⑦ 重設濾芯提示系統

## (五) 安裝及使用指引

1. 請將本產品放置在陰涼、通風、穩固的表面上，遠離熱源。

### 2. 安裝接水盤

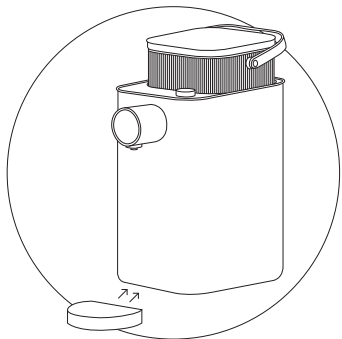

從包裝中取出接水盤，將接水盤靠近機身底中間磁性連接。

### 3. 安裝水箱手柄

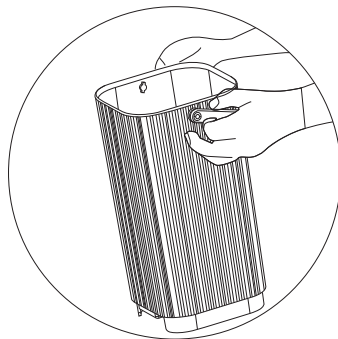

將手柄內側放在水箱後方（水箱標有MAX最高水位為後方），手柄頂端卡位對準水箱兩側安裝孔，稍稍用力向內壓即可裝上。

### 4. 安裝濾芯（如不使用濾芯請略過）

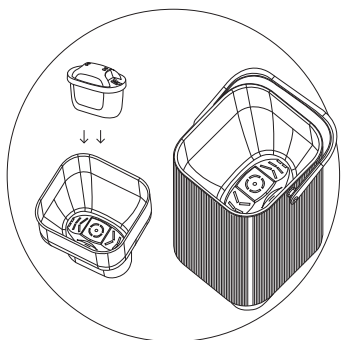

將濾芯包裝拆開，參考各品牌的濾水壺濾芯安裝指引，把濾芯的底部與未過濾水箱內的凹槽對齊，向下輕壓，將濾芯壓至凹槽內即可。

### 3. 放入水箱

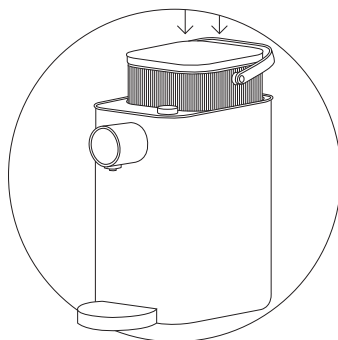

水箱注水後，蓋上水箱蓋，將水箱輕輕向下壓，讓水箱連接到感應器。

### (1) 初次使用步驟：

產品在第一次使用時，請先選擇「常溫」，選擇「500ml」出水量，製作一杯水後倒掉，如此重複操作兩次後方可開始使用。

### (2) 使用步驟：

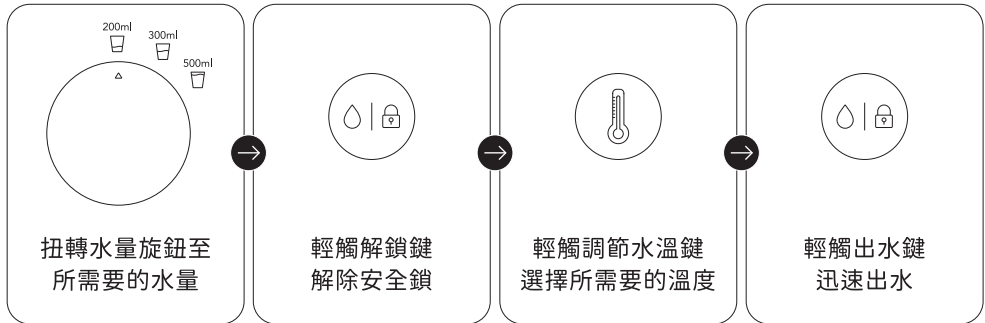

### (3) 指示燈說明：

水量不足提示：當水量不足時，常溫提示燈會閃爍，並發出三聲「滴」聲。

待機指示：解鎖後，三秒內不選擇功能鍵，將自動還原至待機模式，常溫提示燈會亮起。

### (4) 濾芯使用說明：

本產品並無官方標準配置濾芯。本產品隨機附送BRITA（碧然德）MAXTRA+濾水壺專用濾芯一件。



本產品可以搭配濾芯使用。可兼容之濾芯型號\*包括但不限於：

- BRITA MAXTRA+ Universal Filter Cartridge濾水壺濾芯
- BWT 濾水壺專用濾芯 Water Filters (for Water Filter Jugs)
- LAICA bi-flux® Universal Filter Cartridge
- PHILIPS Micro X-Clean Filter

\*以上資料以2021年5月測試基準而得出。實際請以各品牌的濾芯產品型號及指引為準。

### (5) 更換濾芯使用說明：

本產品配備濾芯更換提示系統，每30天\*會提醒您更換濾芯。初次使用濾芯或更換濾芯時，須重設濾芯提示系統。

重設濾芯更換提示步驟：同時按下  +  按鈕約兩秒，直到濾芯更換提示燈轉成白燈。

當提示燈由白燈轉紅燈時，應盡快更換濾芯，然後重複**重設濾芯更換提示步驟**。

註：如產品斷開電源，濾芯更換提示系統將暫停計算時間，重新開機後系統會恢復。如將會停止使用產品一段時間，建議將濾芯取出另外儲存，並將產品斷開電源。

\*30天為建議更換濾芯時間，實際濾芯更換之時間及程序請以濾芯產品的使用指引為準。

## (6) 實際出水溫度及水量偏差說明：

- 因使用產品地之海拔高度的客觀因素，出水溫度或略有偏差。
- 因使用產品地之實際電壓、海拔等客觀因素，出水量或略有偏差。
- 可選擇之溫度為內發熱體的水所達到的溫度，而水從發熱體到出水口會有一定比例的自然熱力流失，杯中溫度或略有偏差。
- 因實際環境溫度及自然熱力流失影響，杯中溫度或略有偏差。

\*以上資料來自實驗室實驗結果，實際使用過程中因環境變化或有細微不同。

## (六) 注意事項

- 請勿在本產品使用不明水源。
- 請看管孩童，避免他們將本產品視為玩具，以免造成危險。
- 使用本產品前請檢查插座承載功率足夠大，以防線路過載，請檢查所用的電壓、功率是否與產品標籤相符。
- 電源插座必須可靠接地，插座額定電流應該大於10A，在使用中如果發現機身有麻電的感覺，請立即關閉電源，並請專業電工檢查電源插座。
- 本產品必須放置在室內陰涼乾燥的地方，避免陽光照射，擺放位置不應靠近暖氣設備、電熱產品或其他高溫場所。
- 請勿將本產品放置在會出現或有可能出現可燃性氣體洩漏的場所。
- 本產品僅限家居使用。
- 本產品僅適用於室內安裝使用，不適合戶外或可能有水噴濺的地方安裝使用。
- 請勿擠壓、摔打、碰撞本產品或在本產品上放置重物，以免導致產品損壞。
- 請勿用濕手插拔電源插頭，以免引發觸電危險。
- 請以抓住插頭的方式撥出電源線，請勿直接拉扯電源線，或任意加長電源線，以免引起火災。請勿在未加水的情況下開機，以免乾燒。
- 請在移動本產品前拔掉電源插頭。
- 請勿接觸本產品出水口，以免燙傷。
- 當使用熱水後如須馬上使用常溫或較低溫水，請先放出常溫水，10秒後再取水，以免造成燙傷。
- 請勿將本產品浸入水中（包括電源線、電源插頭），以免發生危險。
- 請勿在本產品通電運作時取下水箱。
- 請將本產品放置在平穩、牢固、水平的表面上。
- 請勿將本產品放置在電器設備上。
- 本產品的維修保養須使用指定的部件或配件（濾芯除外）。
- 倘若產品發生故障，請立即斷開電源，並交由製造商的專業人員進行檢修，請勿自行拆解維修本產品，以免因不當的維修造成危險。

## (七) 清潔與保養

- 為防止觸電，請先斷開電源再進行產品日常保養。
- 請勿將機器直接浸泡於水中、用水直接沖洗機身或用噴濺水清洗本產品。
- 請勿用氣體或化學藥劑擦拭機身，避免機器表面褪色，建議使用適量的清水或少量中性清洗劑配合棉布輕輕擦拭。
- 長期停用本產品時請斷開電源及將濾芯取出。
- 請定期清洗水箱、接水盤及接水盤蓋，可配合少量中性清洗劑清洗，再用清水洗淨。
- 如預料兩天或以上會不使用水機，建議排空機器和水箱裡的水，然後斷開電源。
- 清潔保養後，請按初次使用步驟準備。

## (八) 故障判斷

本產品在使用過程中出現下列情況屬於正常現象，請放心使用。

1. 在加熱過程中會有水泵抽水的聲音；
2. 加入的水溫度較低時，制熱速度會相對慢一點；
3. 在海拔較高的地方使用本產品，出水溫度會相對低一點；
4. 在海拔較高的地方使用本產品，在較高溫度的模式下制水時，可能會出現出水及噴蒸氣現象；
5. 杯中溫度主要受環境溫度及自然損失影響，與水機表示的溫度略有偏差。

\*具體描述請參考實際溫度及水量偏差說明。

使用過程中如有疑難故障，請諮詢本公司授權之經銷商或服務商檢修。

為了節省您的時間，送檢前，請參照以下情況自行檢查。

### 常見故障判斷及處理

故障現象	故障可能的原因	解決對策
水機不運作	水機未通電	檢查電源連接是否正常
水機無法出水	水機處於安全鎖狀態	解除安全鎖
出水流速過慢	雜質堵住進水	檢查進出水口是否堵住
		檢閱是否需要更換濾芯
水機發出提示聲	缺水警報	加水
	初次使用不當	重複 <b>初次使用步驟</b>
出水味道異常	初次使用	重複 <b>初次使用步驟</b>
	機器長時間沒有使用	重複 <b>初次使用步驟</b>
	機器使用過有氣味的液體制熱	不可在氣味過重的環境下使用，本產品只能對飲用水進行加熱



## (九) 裝箱清單

主機	1
接水盤	1
使用說明	1
水箱手柄	1

## (十) 產品保修說明

本產品享有購買日期起計一年保修服務（以購買發票之日期為準）。請於購買日期起計14日內完成產品保用登記，保修服務方正式生效。請妥善保存購買發票正本，送修時必須出示。發票上之產品型號必須與機身相符，方為有效。保修期內，凡經本公司授權維修人員確認產品問題為生產時造成之損毀，則可獲得免費保修服務。

下列項目並不包括於免費保修範圍內。客戶須另付所需的服務費用。

1. 修理或更換產品之附件、外接線及機殼。
2. 曾被非服務中心的技術員明顯地或不明顯地進行改裝、更改或修理的產品。
3. 曾經被不適當或疏忽使用、不正常供電或電壓不正常、意外、天災或因昆蟲、外物、液體入侵、腐蝕或外來因素而造成損壞的產品。
4. 未有按照原廠之指示安裝及操作產品而引致的故障。

### 網上保用登記

請瀏覽W.A.S.H官方網站或掃描二維碼前往登記您的產品。

[www.wash.com.hk/](http://www.wash.com.hk/)



# CONTENTS

(01) Product Introduction	10
(02) Product Specifications	10
(03) Product Overview	11
(04) Interface	11
(05) Installation & Instruction	12 - 14
(06) Precautions	14
(07) Cleaning and Care	15
(08) Troubleshooting	15 - 16
(09) Packing List	17
(10) Warranty Service	17

## (01) Product Introduction

Thank you for purchasing. This is a Hot Water Dispenser with water filter. With instant heating technology powered by 2000W, it provides water of different temperatures within 3 seconds. Provided with 5 options of temperatures (Room Temperature, 45°C, 65°C, 80°C and 95°C), it enables you to prepare a wide variety of beverages and food conveniently.

- Minimal and attractive appearance - fit in any corners of your home/office
- 2000W fast heat up - dispense within 3 seconds
- Temperature: Room Temperature / 45°C / 65°C / 80°C / 95°C
- 3 Dispensing Modes – 200ml、300ml、500ml
- 3.6L Water Tank
- Safety Lock Protection
- Filter Replacement Reminder

## (02) Product Specifications

Product Name	Hot Water Dispenser with Water Filters Mark II
Model No.	WD3625W
Rated Power	2000W
Rated Voltage	220V~
Applicable Water Source*	Purified Water/Mineral Water/Municipally treated tap water or with water from private supplies that has been approved safe to drink
Inlet water temperature*	5~40°C
Capacity*	3.6L (Max. water level)
Capacity (Filtered Water)	1.6L
Weight	2.2kg
Dimensions	153W x 246D x 320H mm

### (03) Product Overview

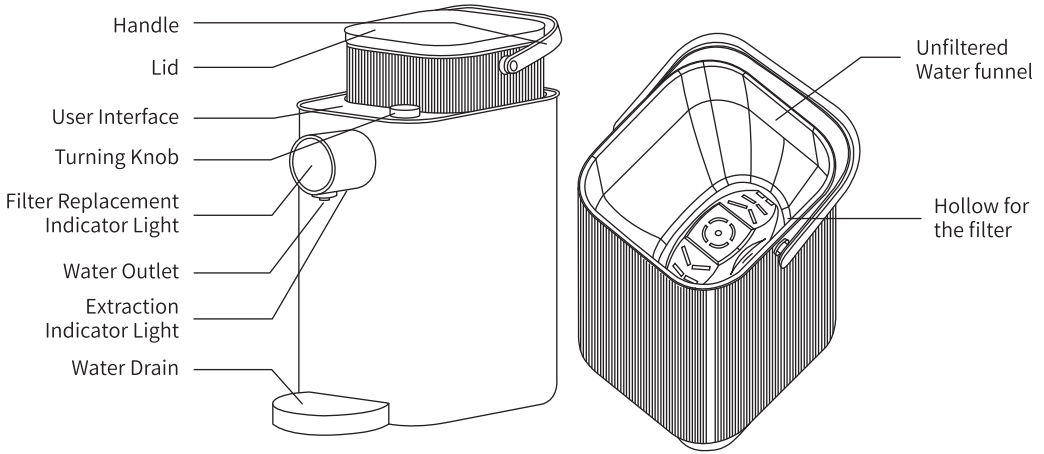

### (04) User Interface

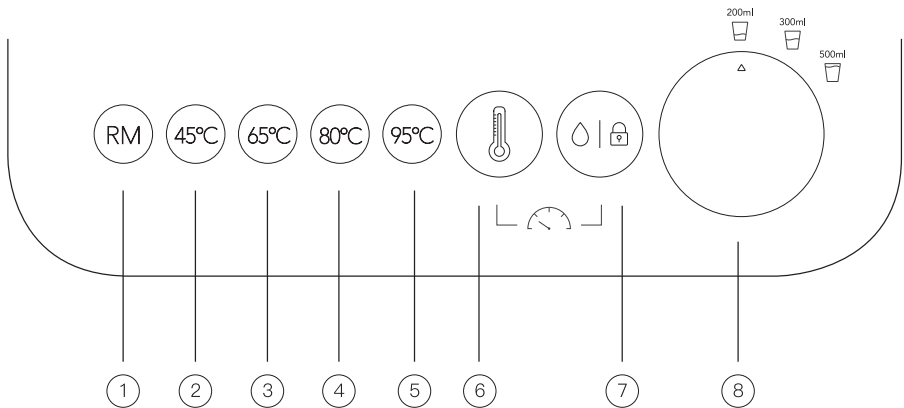

- ① Room Temperature Indicator      ④ 80°C Indicator      ⑦ Water Extraction/Unlock Button
- ② 45°C Indicator                      ⑤ 95°C Indicator      ⑧ Rotary Volume Selection Knob
- ③ 65°C Indicator                      ⑥ Temperature Selection Button
- ⑥ + ⑦ Reset Filter Replacement Reminder System

## (05) Installation & Instruction

1. Please place the dispenser on a stable and horizontal surface, where is cool, well-ventilated and away from direct sunlight and hot elements.

### 2. Water Drain Installation

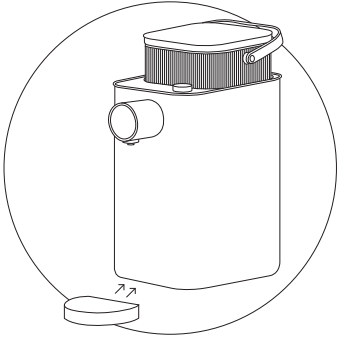

Attach the magnetic water drain to the front-bottom of the dispenser.

### 3. Water tank handle installation

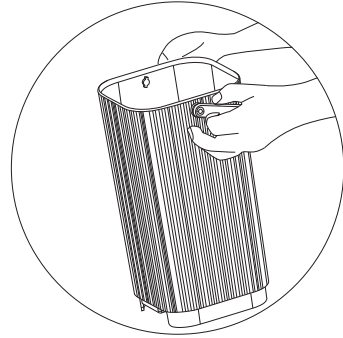

Align the handle with the mounting holes on both sides of the water tank. Press it inward slightly to install it. (MAX water level marked as back side)

### 4. Water filter installation (Optional)

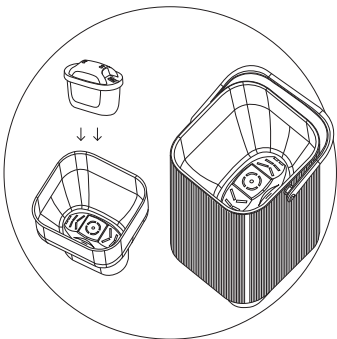

Prepare the water filter according to its instructions. Align the bottom of the filter to the hollow for the filter on the unfiltered water funnel. Slightly press the filter to attach to the hollow.

### 3. Water tank installation

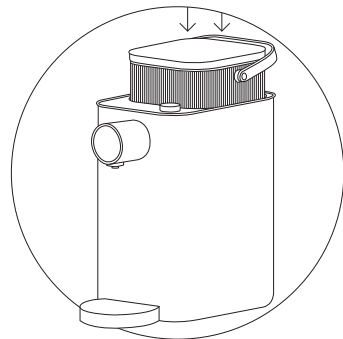

After filling water into the water tank, cover the lid and install the water tank back to the dispenser. Slightly press the water tank to connect to the water detector.

### (1) First time using

During first time use, please extract a cup of water with “500ml” and “RM” by following the instruction **(2) How to Use it**. Repeat twice and start using it.

### (2) How to Use it

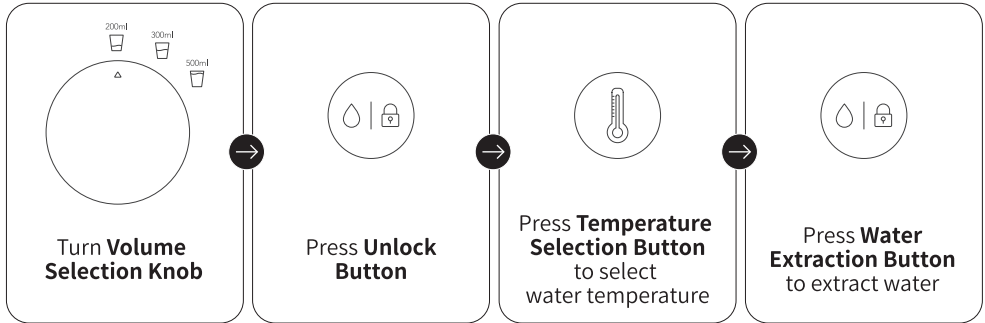

### (3) Indicator Light

**Lack of water: Indicator Light at “RM”** will fade in and out three times.

**Sleep Mode:** If no operation is taken within 3 seconds after unlocking, the appliance will automatically return to standby mode. **Indicator Light** will show at “RM”.

### (4) Filter Cartridge Usage

There is no default filter cartridge designated for this product.

A complimentary of BRITA MAXTRA+ filter cartridge is supplied with this product.



This product can be used with filter cartridge. Compatible filter models\* include but are not limited to:

- BRITA MAXTRA+ Universal Filter Cartridge
- BWT Water Filters (for Water Filter Jugs)
- LAICA bi-flux® Universal Filter Cartridge
- PHILIPS Micro X-Clean Filter

\*The above information is based on the test practiced in May 2021. Please refer to the filter product model and guidelines of each brand respectively.

## (5) Filter Replacement Reminder

There is a Filter Replacement Reminder System in this product. It reminds you to replace your water filter every 30 days\*.

When you use a new water filter, press and hold on  +  buttons until the filter replacement indicator light changes to white to reset the Filter Replacement Reminder System.

When the indicator light changes to red, please replace the filter and reset the system.

Reminder: The Filter Replacement System stops counting time when the product is disconnected from power. If you are not using the product for a period of time, you are suggested to unplug the product and take out the filters and store individually.

\*30 days are suggested lifetime for a filter and only for reference. Please refer to the official guidelines and lifetime description of the filters.

## (6) Actual Water Temperature and Volume Error

- Due to the objective factors of the altitude where the product is being used, the water temperature from the water outlet may have a slight error.
- Due to objective factors such as the actual voltage and altitude of the place where the product is being used, the volume from the water outlet may have a slight error.
- The temperature of the five options are the temperature that the water in the inner heating part of the appliance can reach. A certain proportion of natural heat loss will be caused from the inner part to the water outlet. The water temperature in the cup may have a slight error.
- Due to the actual ambient temperature and natural heat loss, the water temperature in the cup may have a slight error.

\*The above information comes from laboratory experiment results. There may be slight differences due to environmental changes during actual use.

## (7) Precautions

- Do not use any water of unknown source.
- Children should be supervised to ensure that they do not play with the appliance.
- Before using this product, please check that if the power of the socket is large enough for this product to avoid overload circuit. Please check whether the voltage and power used are consistent with the product specifications.
- The power socket must be reliably grounded, and the rated current of the socket should be greater than 10A. If you find that the body feels numb when using it, please turn off the power immediately.
- Place the dispenser indoors where is cool and well-ventilated. Keep away from direct sunlight, heating elements, or anywhere is hot.
- Do not place the dispenser in place that may have inflammable gas leakage.
- This product is intended for household use only.
- This dispenser is intended for indoor use. Do not place in a place where water can spill.

- Do not extrude, hit, collide the dispenser or put any heavy objects on the appliance to avoid damage.
- Do not plug or unplug with wet hands to avoid electric shock.
- Always unplug the appliance by pulling the power plug rather than the cord. Do not use an extension cord to avoid overload and fire.
- Do not turn on the appliance when water is not filled so as to avoid dry-boling.
- Unplug the appliance before moving it.
- Do not touch the water outlet to prevent scalding.
- If you intend to extract ambient water immediately after extracting hot water, please extract water of room temperature for 10 seconds first to avoid being burnt by hot water.
- Do not immerse this product in water (including power cords and power plugs).
- Do not remove the water tank when the appliance is working.
- Place the appliance on a flat, stable surface.
- Do not place the appliance on other electrical appliances.
- Always use certified elements and accessories for the repairment and maintenance of the appliance. (Excluding filter cartridge)
- If there is any abnormality, please stop using the appliance and unplug it immediately. To avoid risks of danger, do not disassemble or repair the appliance by yourself. Please hand it over to a qualified electrician.

## (7) Cleaning and Care

- To prevent electric shock, please disconnect the appliance from the power supply before cleaning and maintenance of the appliance.
  - Do not immerse the appliance in water, rinse it or use water spray to clean it.
  - Do not use gas or chemical agents to wipe and clean the appliance to avoid fading of the surface of the machine. It is recommended to use a small amount of water or a small amount of neutral detergent to clean it with cotton cloth.
  - Please disconnect the appliance from the power supply if it will not be used for a long time.
  - Please clean the water tank, water drain and lid regularly. It is recommended to use a small amount of water or a small amount of neutral detergent to clean it with cotton cloth. If the appliance will not be used for two days or above, please empty the water tank and disconnect the appliance.
- After cleaning and care, please follow the procedure of “First time using” to get the appliance ready.



## (8) Trouble Shooting

The situations stated below are normal:

1. Sound of water pumping will occur during heating.
2. The heating speed will be relatively slow if lower temperature of water is filled into the water tank.
3. The water temperature from the water outlet will be relatively lower if this product is being used at a place of higher altitude.
4. Water and steam may appear when using higher temperature mode at a place of higher altitude.
5. The water temperature in the cup is mainly affected by the ambient temperature and natural heat loss. There would be a slight deviation from the temperature indicated by the machine.

\*For more details, please refer to the description in **Actual Water Temperature and Volume Error**.

Before repairing, please check the following items. For any inquiries, please contact our authorized distributor or service center.

### Problems and Solutions

Fault	Probable Causes	Solutions
Appliance is not working	The product is not connected with the power supply	Check if the appliance is well connected with power supply
Cannot extract water	The appliance is locked	Press "Unlock"
Slow water velocity	Impurities blocking the water inlet	Check if the water inlet is blocked, and clean it
		Check if the water filter is required to be replaced
Alert rings	Lack of water	Fill in water
	Improper use for first time	Repeat <b>First time using</b>
Abnormal taste and smell of water	Improper use for first time	Repeat <b>First time using</b>
	Not being used for long time	Repeat <b>First time using</b>
	Filled in other liquid rather than water	Only available for water and place the appliance at where without odor

## (9) Packing List

Dispenser	1
Water Drain	1
User Manual	1
Water Tank Handle	1

## (10) Warranty Service

One (1) year warranty service is offered to this product commencing from the date of purchase invoice. Please register your product within 14 days of purchase. The warranty service will only be valid after submission of warranty registration. Customer is required to present the official purchase invoice issued by the authorized dealers to our technician for verification when service is rendered. The warranty service is valid only if the model number stated herein corresponds with that of the product and the date of purchase stated herein is the same with the date of official purchase invoice. If there is damage on the products under normal circumstances proved by our technicians, free repairing service will be provided.

The warranty service does not apply to:

1. Repairment or Replacement of the accessories, power cord or case of the appliance.
2. Products that have been modified, altered or repaired obviously or inconspicuously by unauthorized technicians
3. Products that have been damaged by improper or negligent use, abnormal power supply or voltage, accidents, natural disasters, or damage caused by insects, foreign objects, liquid intrusion, corrosion, or other external factors.
4. Failure to install and operate the product in accordance with the instructions provided by the original manufacturer.

### Online Warranty Registration

Visit our website or scan the QR CODE to register your product.

[www.wash.com.hk/warranty](http://www.wash.com.hk/warranty)





W.A.S.H reserves the right of final decision in case of any dispute arising herein. The product design, specifications and functions in this manual are for reference only. Actual product may vary. Product details are subject to change without prior notice. In case there is any inconsistency or conflict between English version and Chinese version of the terms, the Chinese version shall prevail.

如有任何爭議，W.A.S.H 保留最終決定權。本說明書中產品設計、規格及功能僅供參考，實際產品功能和規格可能會有不同。產品資料如有更改，恕不另行通知。如中英文版本有差異時，應以中文版為準。

# W · A · S · H

W A T E R · A I R · S U N · H O M E

[www.wash.com.hk](http://www.wash.com.hk)

**WATER AIR SUN & HOME COMPANY LTD**

TEL: (852) 3521 0037

EMAIL: [info@wash.com.hk](mailto:info@wash.com.hk)